

INSTALLATION OPERATION MAINTENANCE

TCH-IOM-10
18-AB33D6-10

Models:

TCH024C1	TCH042C1
TCH030C1	TCH048F1
TCH036C1	TCH060F1

**Packaged Cooling
Electric Heat
Over/Under
2, 2-1/2, 3, 3-1/2, 4, 5 Tons**

IMPORTANT—This Document is customer property and is to remain with this unit. Please return to service information pack upon completion of work.

⚠ WARNING: HAZARDOUS VOLTAGE - DISCONNECT POWER BEFORE SERVICING

ALL phases of this installation must comply with NATIONAL, STATE, and LOCAL CODES.

These instructions do not purport to cover all variations in systems nor to provide for every possible contingency to be met in connection with installation. Should further information be desired or necessary or should particular problems arise which are not covered sufficiently for the purchaser's or installer's needs or purposes, the matter should be referred to the manufacturer.

⚠ WARNING

THIS INFORMATION IS FOR USE BY INDIVIDUALS HAVING ADEQUATE BACKGROUNDS OF ELECTRICAL AND MECHANICAL EXPERIENCE. ANY ATTEMPT TO REPAIR A CENTRAL AIR CONDITIONING PRODUCT MAY RESULT IN PERSONAL INJURY AND/OR PROPERTY DAMAGE. THE MANUFACTURER OR SELLER CANNOT BE RESPONSIBLE FOR THE INTERPRETATION OF THIS INFORMATION, NOR CAN IT ASSUME ANY LIABILITY IN CONNECTION WITH ITS USE.

⚠ CAUTION

Reconnect all grounding devices.

All parts of this product that are capable of conducting electrical current are grounded. If grounding wires, screws, straps, clips, nuts, or washers used to complete a path to ground are removed for service, they must be returned to their original position and properly fastened.

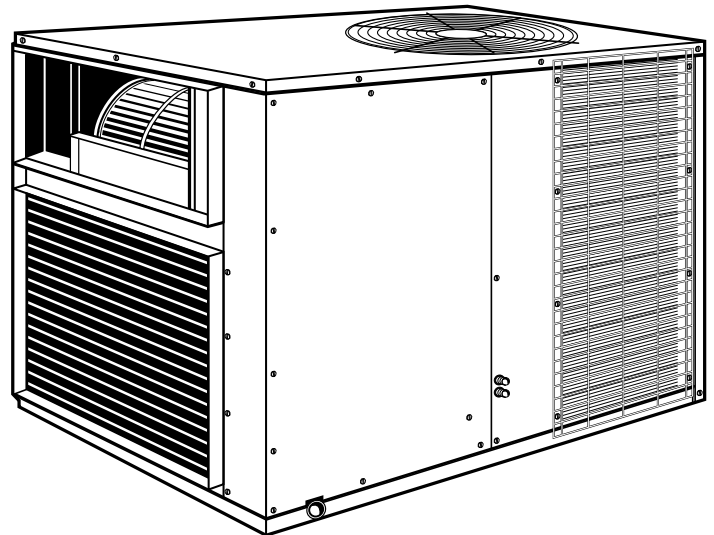

2, 2-1/2, 3, 3-1/2 Tons Shown

⚠ CAUTION

CONTAINS REFRIGERANT!
SYSTEM CONTAINS OIL AND REFRIGERANT UNDER HIGH PRESSURE. RECOVER REFRIGERANT TO RELIEVE PRESSURE BEFORE OPENING SYSTEM. Failure to follow proper procedures can result in personal illness or injury or severe equipment damage.

The manufacturer has a policy of continuous product and product data improvement, and it reserves the right to change design and specification without notice.

General Information

These instructions cover installation, operation, and maintenance of all single package **TCH024-060** air conditioning units. For an easy and orderly installation, follow the sequence of instructions as they are outlined. Improper installation can result in unsatisfactory operation and/or dangerous conditions as well as make the related warranty inapplicable. Read this manual carefully before installing, operating, or performing maintenance on this unit. Installation and maintenance should be performed by qualified service technicians. Locate the unit in accordance with local codes or the National Electrical Code. Each unit contained an operating charge of HCFC-22 when shipped.

Unit Inspection

The material in this shipment has been inspected at the factory and was released to the transportation agency without known damage. Inspect the exterior of the carton for evidence of rough handling in shipment. Check the unit nameplate to determine if the unit is correct for the intended application. After moving the equipment to the approximate location, unpack it carefully. If damage to the unit is found, report the nature of this damage immediately to the delivery agency. Check to be sure that the refrigerant charge has been retained during shipment.

Power Supply

The power supply must be adequate for the unit and any supplementary electric heaters, if added. Make certain that the power supply to the unit agrees with the power requirements specified on the unit nameplate. Separate branch circuits are required for supplementary electric heaters.

Rigging

IMPORTANT: Check the handling facilities to ensure the safety of both personnel and the unit. Be sure that the proper method of rigging is used, with straps or slings and spreader bars for protection during lifting.

WARNING

Do not lift the unit without testing for balance and rigging. Do not lift the unit in windy conditions or above personnel. Do not lift the unit by attaching a clevis, hooks, pins, or bolts to the unit casing, casing hardware, corner lugs, angles, tabs, or flanges. Failure to observe this warning may result in equipment damage.

Locations and Recommendations

This unit was designed for multiple applications: rooftop, outdoor ground level. For proper installation, the following recommendations must be considered:

Installation of the unit should conform to local building codes or, in the absence of local codes, to the National Electrical Code. Canadian installations must conform to CSA and local codes

Select a location that will permit unobstructed airflow into the outdoor coil and away from the fan discharge. The discharge air from the outdoor fan must be unrestricted for a minimum of three (3) feet above the unit. Any reduction of the unit clearances recommended may result in condenser coil starvation or the recirculation of warm condenser air. Actual clearances which are inadequate should be reviewed with a local sales representative. If the unit is located under an overhang, provisions must be made to deflect the warm discharge air from under the overhang. See Figures 1, 2 and 3. The unit must also be situated to permit easy and unrestricted access for service.

Install internal accessories to the unit at the shop if practical.

Position the unit so roof-run-off water does not pour directly onto the unit.

CAUTION MUST ALWAYS BE TAKEN TO AVOID PERSONAL INJURIES AND/OR DAMAGE TO THE EQUIPMENT.

Elevation minimums must be observed for drain line "trap" and ventilation to the under side of the unit.

All duct work inside the structure should be adequately insulated.

All duct work outside of the structure must be insulated and weatherproofed in accordance with local codes. If supplementary heat is added, the duct connectors should be of a flame retardant material.

Access and service clearances for the unit must be given careful consideration when locating the duct entrance openings. Figure 1 provides unit dimensions.

All fabricated outdoor ducts should be as short as possible.

Be sure the openings in the structure are large enough to accommodate the ducts and the insulation surrounding them. See Figure 1.

For outdoor, ground level applications the unit must be mounted on a solid, level foundation that is not adjoined to the structure because sound and vibration may be transmitted to the structure.

Field supplied mounting pads should be placed beneath the unit to prevent transmission of vibration to the occupied structure.

Select a location that will minimize the length of the supply and return ducts.

Select a location where external water drainage cannot collect around the unit.

Give consideration to shade, appearance, and noise.

The following warning complies with State of California law, Proposition 65.

 WARNING: This product contains fiberglass wool insulation! Fiberglass dust and ceramic fibers are believed by the State of California to cause cancer through inhalation. Glasswool fibers may also cause respiratory, skin, or eye irritation.

— TCH024, 030, 036, 042C Unit Dimensions and Clearances —

1

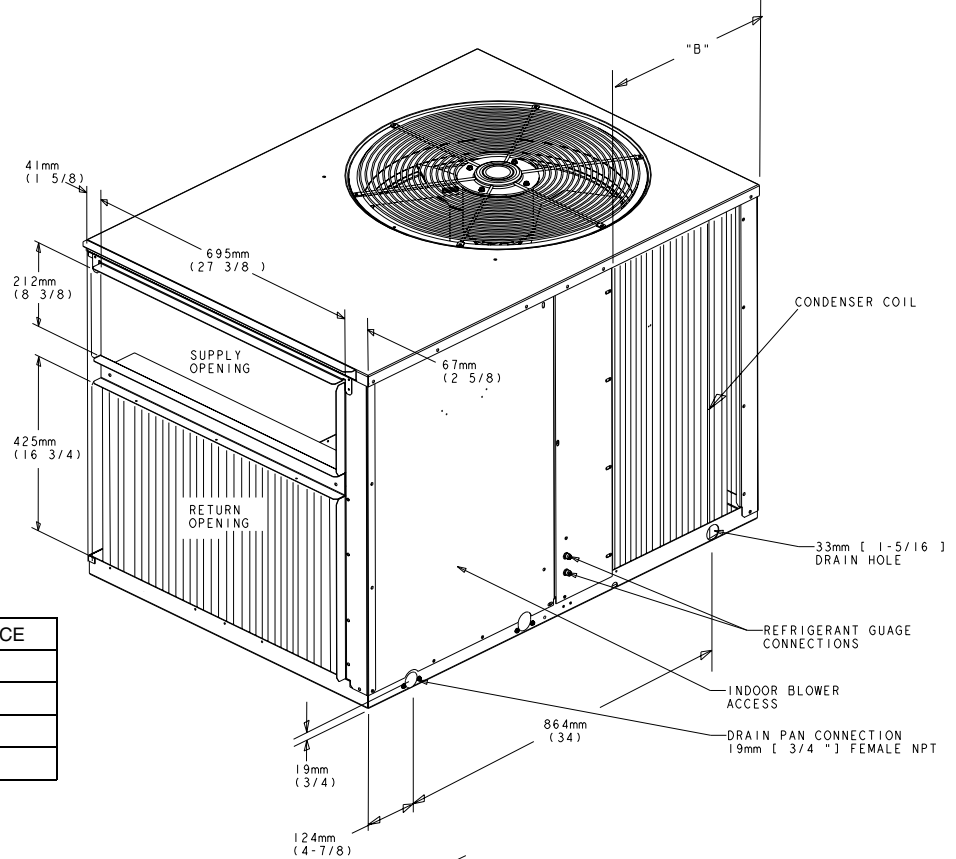

INSTALLATION / SERVICE CLEARANCE	
BACK	48.0"
LEFT SIDE	24.0"
RIGHT SIDE	36.0"
TOP	36.0"

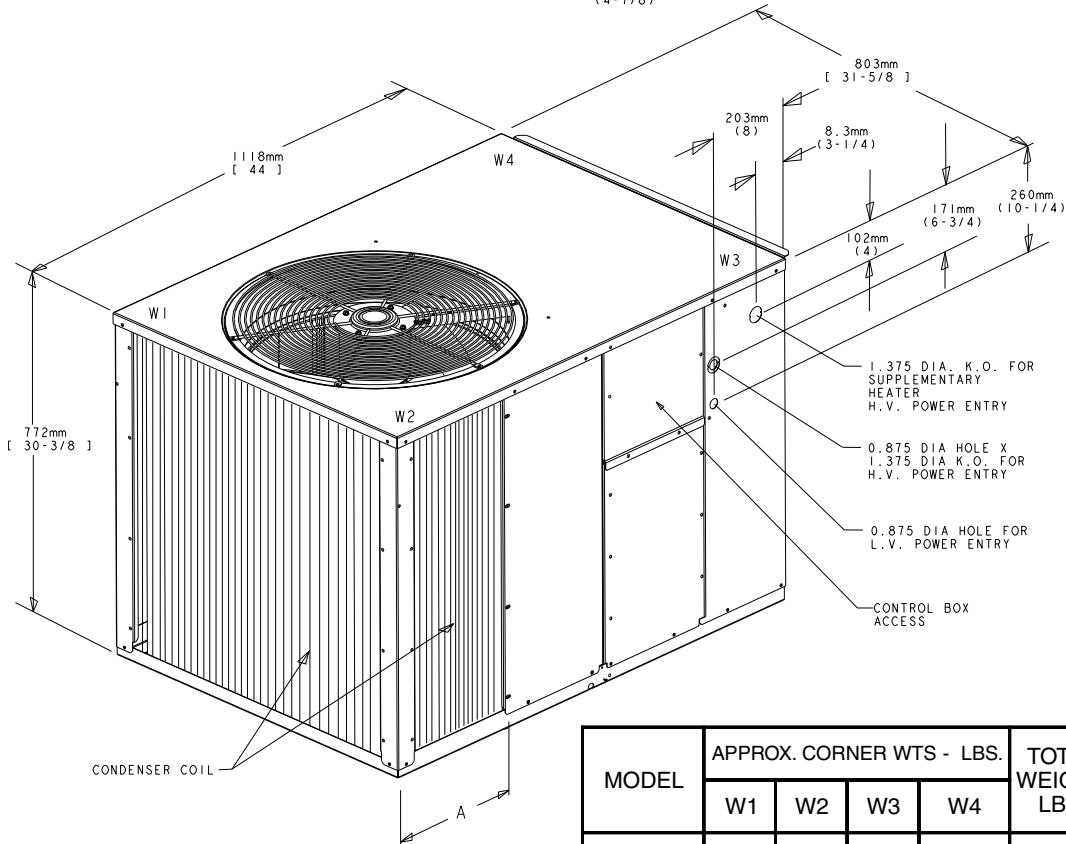

MODEL	APPROX. CORNER WTS - LBS.				TOTAL WEIGHT LBS.	COIL DIMENSION (IN)	
	W1	W2	W3	W4		A	B
TCH024C	76	73	63	68	279	14	16
TCH030C	77	71	62	70	281	14	16
TCH036C	79	75	66	73	293	14	16
TCH042C	80	79	72	77	308	20	16

Dwg. No. D673590 REV. 0

TCH048, 06F1 Unit Dimensions and Clearances

1

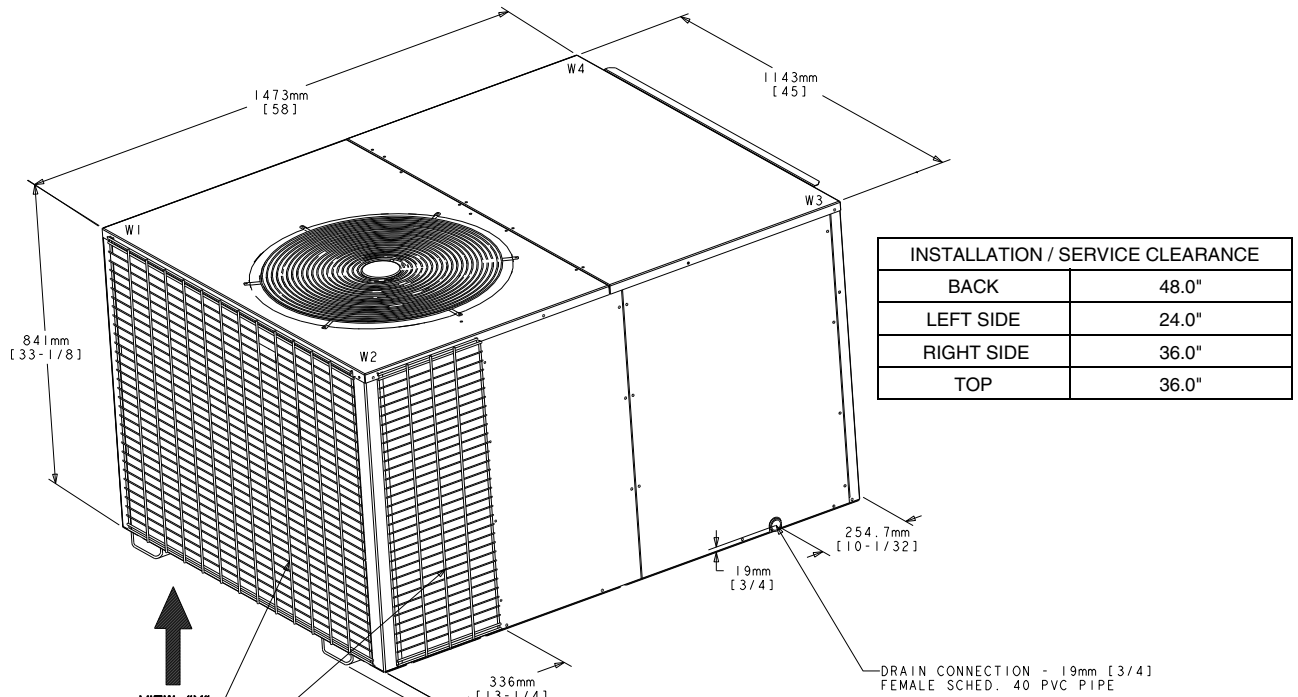

VIEW "X"

NOTE: 3/4" SUPPORT RAILS LOCATED UNDERNEATH BASE OF UNIT

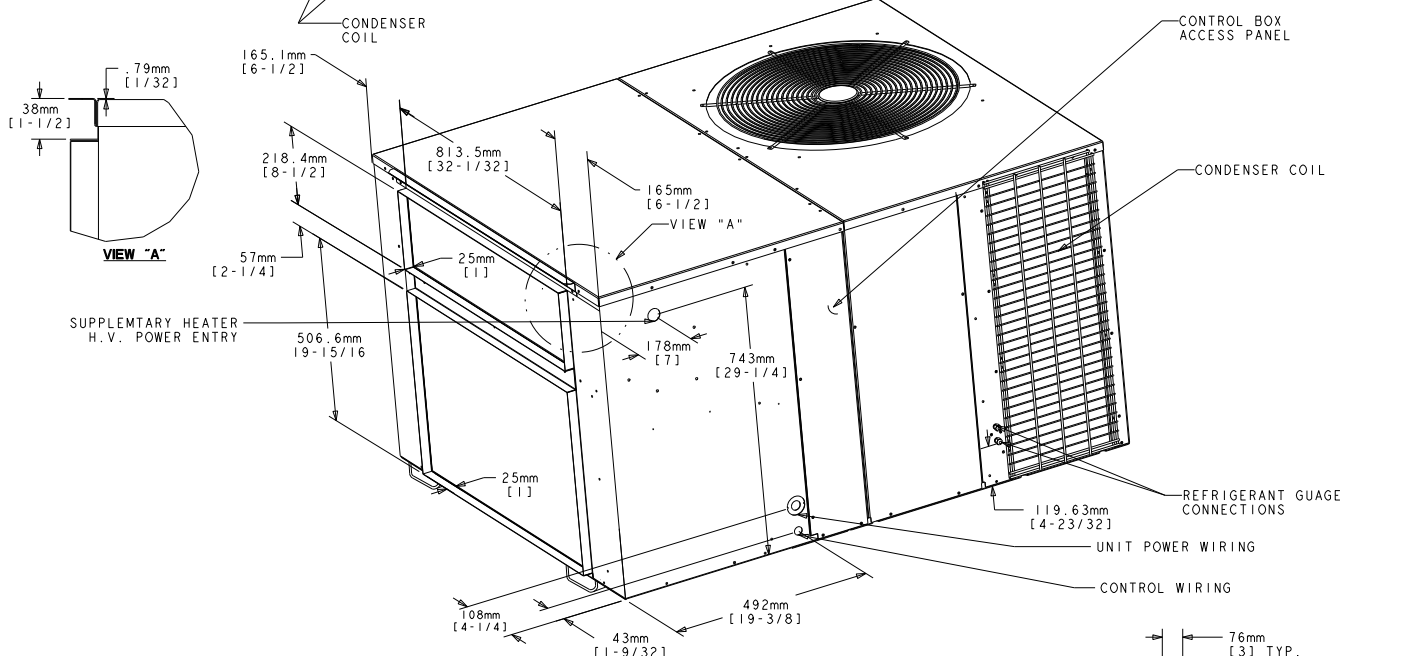

VIEW "A"

VIEW X-X

MODEL	APPROX. CORNER WTS - LBS.				TOTAL WEIGHT LBS.
	W1	W2	W3	W4	
TCH048F	126	126	95	95	443
TCH060F	112	112	111	111	450

Installation Applications

Roof Top

For roof top installations, the roof must have sufficient structural strength to support the load. FHA approved construction and local codes are normally adequate provided the roof joists and rafters have a proportionally distributed load. See Figure 2.

The unit should be positioned for recommended clearances as previously outlined under "**Location and Recommendations**"

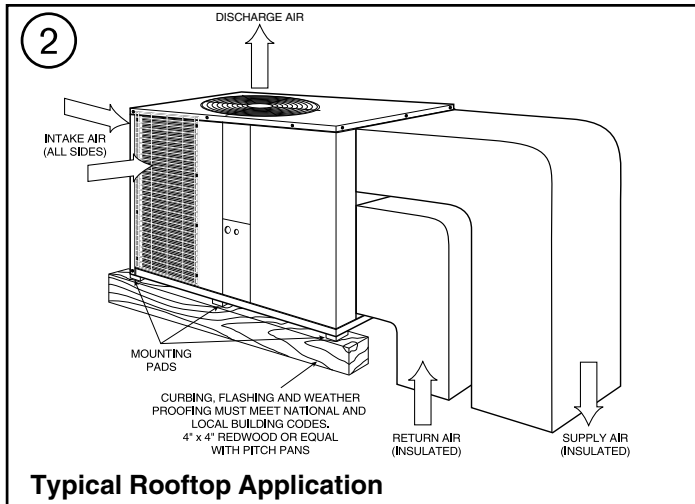

If duct hood or supply and return ducts are fabricated by the installing contractor, be sure that the portion of the supply and return ducts located outdoors is as short as possible. The supply duct, return duct, and connectors should be insulated with 2 inches of insulation and weatherproofed. Be sure the openings in the structure for the supply and return ducts are large enough to include the insulation.

Use turning vanes inside the supply and return ducts when using a square elbow take-off from the unit.

Vibration isolators are recommended to prevent transmission of vibration to the structure. Isolate with at least four (4) vibration isolators or equivalent. The isolators must provide a minimum clearance of 1/4" beneath the unit to permit air to circulate under the unit's base.

After the unit has been properly positioned, complete the installation according to the instructions in the following sections of this manual. Then follow the Start-Up procedure on page 6 and the Checkout procedure on page 10 of this manual.

Ground Level - Outdoor

For ground level installations, position the unit on a pad at least two (2) inches larger than the unit on all sides. The unit must be level on the pad. The pad must not contact the structure. Be sure the outdoor portion of the supply and return air ducts are as short as possible.

The installation should proceed as follows:

The unit must be isolated with mounting pads. The mounting pads must provide a minimum of 1/4" clearance beneath the unit to permit air circulation and prevent corrosion of the base. See Figure 3.

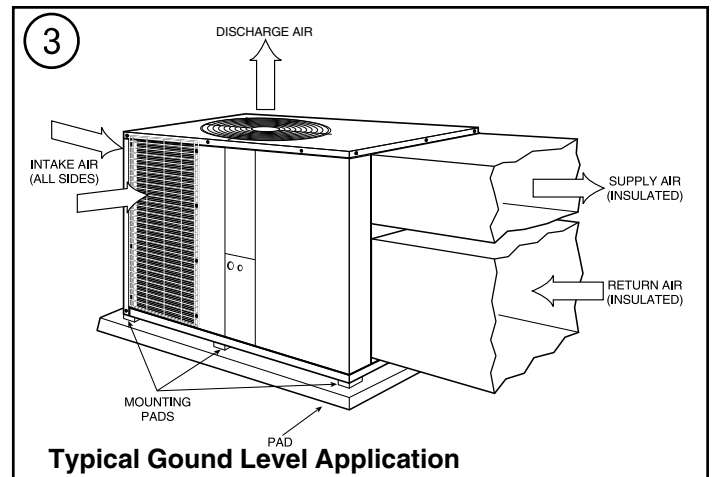

Attach the supply and return air ducts to the unit. The portion of the supply and return ducts located outdoors must be as short as possible.

Insulate any ductwork outside the structure with at least 2 inches of insulation and weatherproofing. Be sure the openings in the structure are large enough to include ducts and insulation.

Complete the installation according to the instructions in the following sections of this manual.

Condensate Drain Piping

A 3/4-inch female NPT condensate drain connection is provided on the evaporator end of the unit. See Figure 1. Provide a trap and fill it with water before starting the unit to prevent air from being drawn through. Follow local codes and standard piping practices when running the drain line. Pitch the line downward away from the unit. Avoid long horizontal runs. See Figure 4.

NOTE: Do not use reducing fittings in the drain line.

The condensate drain must be:

- Made of 3/4" pipe.
- Pitched 1/4" per foot to provide free drainage to a convenient drain system
- Trapped
- Not connected to a closed drain system.

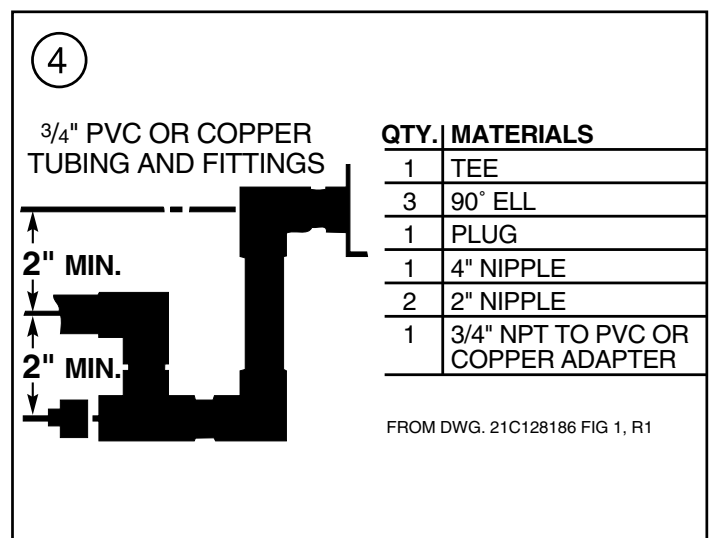

▲WARNING: TO PREVENT INJURY OR DEATH DUE TO ELECTRICAL SHOCK OR CONTACT WITH MOVING PARTS. LOCK UNIT DISCONNECT SWITCH IN OPEN POSITION BEFORE SERVICING UNIT.

Electrical Connections

Electrical wiring and grounding must be installed in accordance with local codes or, in the absence of local codes, with the National Electrical Code ANSI/NFPA 70, Latest Revision.

Disconnect Switch

Provide an approved weather-proof disconnect either on the side of the unit or within close proximity and **within sight of the unit.**

Over Current Protection

The branch circuit feeding the unit must be protected as shown on the unit rating plate.

Power Wiring

The power supply lines must be run in weathertight conduit to the disconnect and into the bottom of the unit control box. Provide strain relief for all conduit with suitable connectors.

Provide flexible conduit supports whenever vibration transmission may cause a noise problem within the building structure.

Ensure all connections are made tight. See Figures 5 and 6: Typical Field Wiring Diagrams.

NOTES:

1. For branch circuit wiring (main power supply to the unit disconnect), wire size for the length of run should be determined using the circuit ampacity found on the unit nameplate and the N.E.C.
2. For more than 3 conductors in a raceway or cable, see the N.E.C. for derating the ampacity of each conductor.
3. Wire size is based on 75 degrees C rated wire insulation.

Grounding

The unit must be electrically grounded in accordance with local codes or the National Electrical Code.

Accessories

All electrical accessories must be installed and wired according to the instructions packaged with the accessory.

Control Wiring (Class II)

Low voltage control wiring should not be run in the same conduit with the power wiring unless Class I wire of the proper voltage rating is used. Route the thermostat cable or equivalent single leads of No. 18 AWG colored wire from the thermostat subbase terminals through the rubber grommet on the unit. See Figure 1 for the control entry location. Make connections as shown on the unit wiring diagram and in Figures 5 and 6.

Do not short thermostat wires since this will damage the control transformer.

Recommended wire sizes and lengths for installing the unit thermostat are provided in **Table 1: Thermostat Wire Size and Maximum Length.** The total resistance of these low voltage wires must not exceed one (1) ohm. Any resistance in excess of one (1) ohm may cause the control to malfunction because of the excessive voltage drop.

IMPORTANT: Upon completion of wiring check all electrical connections, including factory wiring within the unit.

Make sure all connections are tight. Replace and secure all electrical box covers and access doors before leaving the unit or turning on the power to the unit.

After all electrical wiring is complete, set the thermostat system switch on the **OFF** position so that the compressor will not run and then apply power by closing the system main disconnect switch. This will activate the compressor sump heat. Do not change the Thermostat System Switch until power has been applied long enough to evaporate any liquid HCFC-22 in the compressor. It is recommended that the sump heat be energized for a minimum of eight (8) hours prior to starting the unit.

**Table 1
Thermostat Wire Size and Maximum Length**

WIRE SIZE	MAXIMUM LENGTH (Ft)
18	75
16	125
14	200

Air Filters

•These units require filters with adequate filter area be provided in the return air duct. Table 2 below gives filter data. The specific location of the filters depends on the type of installation and the layout of the duct system. Be sure the owner is aware of the location of the filter and the need to change them as required. The Filter Size (Sq. Ft.) are based on 300 F.P.M. face velocity. If permanent filters are used, size per mfg. recommendation with clean resistance of .05" WC.

Table 2. Filter Data

UNIT	NOMINAL CFM	FILTER* (Sq Ft) SIZE	FILTER RESISTANCE
TCH024B	800	2.67	0.05
TCH030B	1000	3.33	0.05
TCH036B	1200	4.00	0.05
TCH042B	1400	4.67	0.05
TCH048F	1600	5.20	0.05
TCH060F	2000	6.67	0.05

Typical Field Wiring Diagram

5

TCH024, 030, 036, 042C and TCH048, 060F Units (Cooling Only)

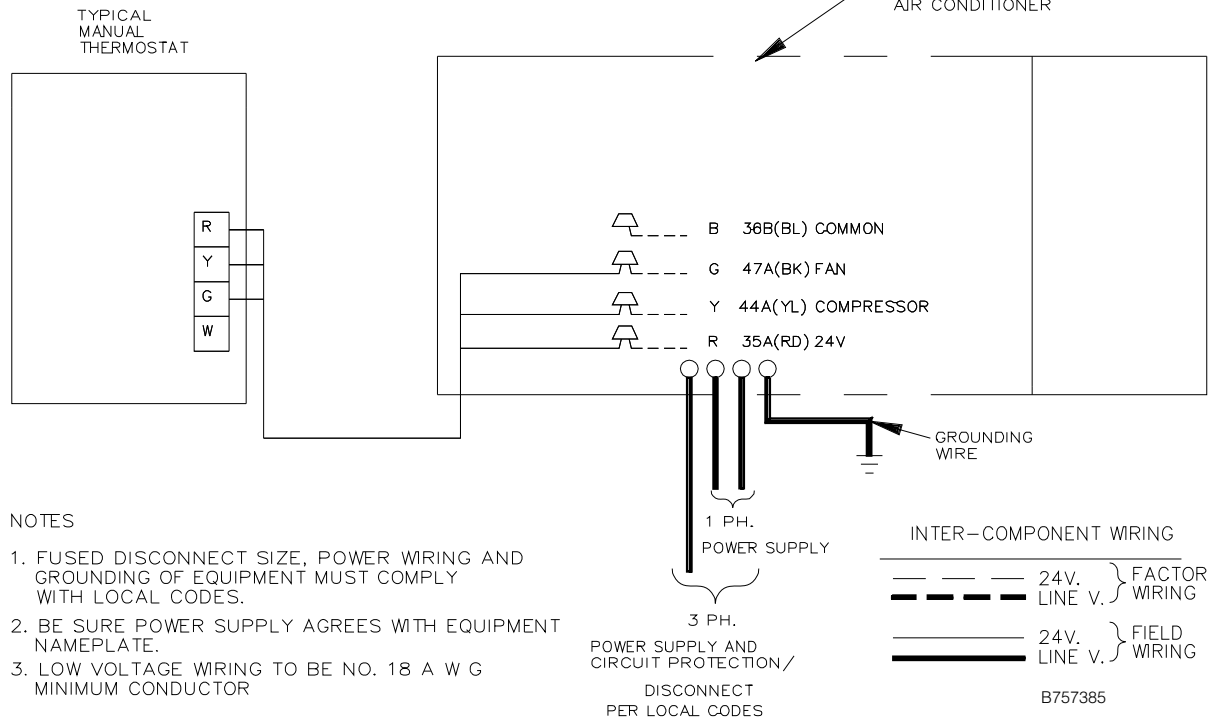

6

TCH024, 030, 036, 042C and TCH048, 060F Units (With Supplementary Heaters)

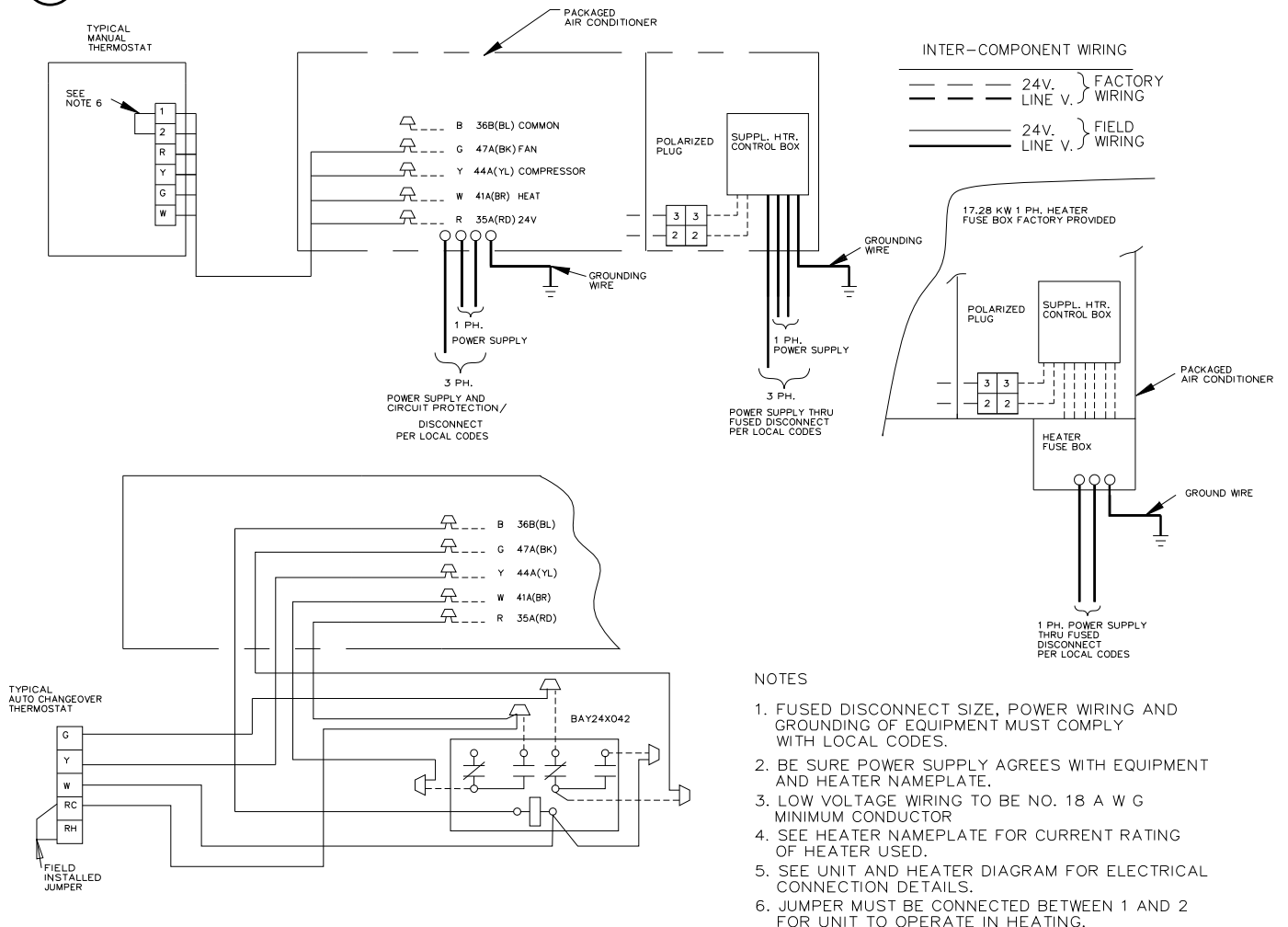

— Sequence of Operation —

The unit's operation is controlled by the remote room thermostat. Once the thermostat is placed in the **COOL** position, the unit's operation is automatic. A fan switch on the thermostat also provides for continuous operation of the evaporator fan if desired. This is the **ON** position. With the fan switch in the **AUTO** position, the fan will only operate with the cooling cycle. Continuous fan mode during cooling operation may not be appropriate in humid climates. If the indoor air exceeds 60% relative humidity or simply feels uncomfortably humid, it is recommended that the fan only be used in the **AUTO** mode.

Cooling

On a call for cooling, the indoor fan "G" and the compressor circuit "Y" are energized. The indoor fan circuit "G" energizes the fan relay coil this closes the fan relay contacts (**FDR-1**) and the indoor fan motor (**IDFM**) starts. The compressor circuit "Y" energizes the (**MS**) contactor coil this powers the compressor (**CPR**) and the outdoor fan motor (**ODFM**). When the thermostat determines that further cooling is not required, the contactors are de-energized.

Short Duration Shut Down

To shut down the unit for a brief period of time, turn the thermostat system switch to **OFF** and place the fan switch in the **AUTO** position.

Heating

On a call for heat, the thermostat "W" is energized, which connects to unit "W", which energizes the "AH" heater contactor coil. The "AH" contactor closes powering the heater, provided all element limits are closed.

Note: The indoor thermostat must be configured for electric heat to provide a "G" signal to energize the indoor fan relay (**FDR-1**) during the heating mode. The heater control circuit will not be energized unless the indoor fan relay (**FDR-2**) is energized.

ICM FAN MOTOR ADJUSTMENTS (TCH048, 060F ONLY)

If the airflow needs to be increased or decreased, see the Airflow Table in the Service Facts. Information on changing the speed of the blower motor is in the Blower Performance Table.

Blower speed changes are made on the ICM Fan Control mounted in the control box. The ICM Fan Control controls the variable speed motor.

There is a bank of 8 dip switches (See Figure 7), located at the upper left side of the board. The dip switches work in pairs to match the cooling/heat airflow (CFM/TON), Fan off-delay options, and electric heat airflow adjustment. The switches appear as shown in Figure 7.

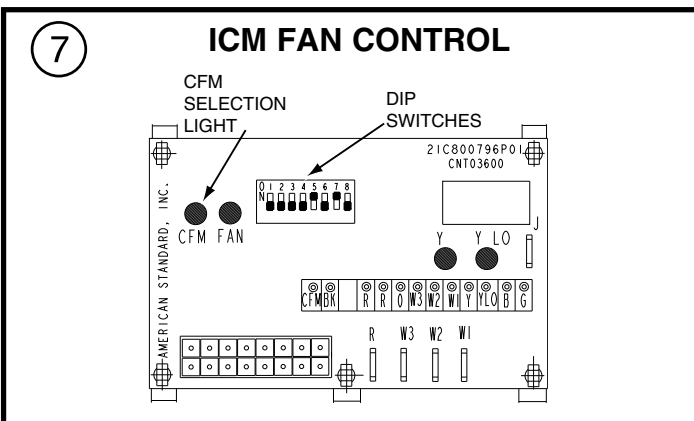

Start-Up

Pre-Start Quick Check List

- Is the unit properly and securely located and level with the proper clearance?
- Is the ductwork correctly sized, run, taped, insulated and weatherproofed with the proper unit arrangement?
- Is the condensate line properly sized, run, trapped, and pitched? Does it drain freely?
- Is the filter of the correct size and number? Are the supply and return registers unobstructed?
- Is the wiring properly sized and run according to the Unit Wiring Diagram, Figures 5 and 6?
- Is the power supply correct for the unit's requirements?
- Are all wiring connections, including those in the unit itself, tight?
- Is the thermostat well located, level, correctly wired, and accurately adjusted?
- Do the outdoor fan and the indoor fan turn free without rubbing? Are both fans tight on their shafts?
- Has the indoor blower speed tap been determined and the proper speed set? See the Unit Wiring Diagram, Figures 5 and 6.
- Has all work been done in accordance to the applicable local and national codes?
- Are all cover and access panels in place to prevent air loss and to protect against safety hazards?
- Have all tools and debris around, on top of, and under the unit been removed?

Starting the Unit In the Cooling Mode

IMPORTANT: Before starting the system in the cooling cycle, turn the thermostat switch to "OFF" and close the unit disconnect switch. This procedure energizes the compressor crankcase heat (if equipped) thereby vaporizing any liquid HCFC-22 in the crankcase. This is a precaution against foaming at start-up which could damage the compressor. Allow the heat to operate for a minimum of eight (8) hours.

The TCH048-060F units do not have sump heat as shipped. **NOTE:** The crankcase heater is a field installed option on some models.

NOTE: See the section on "Sequence of Operation" for a description of the cooling operating sequence.

- To start the unit in the cooling mode, set the thermostat system switch to **COOL**. Move the thermostat **COOL** indicator to a setting below

room temperature. The outdoor fan motor, compressor, and evaporator fan motor will operate automatically.

Operating Pressures

After the unit has operated in the cooling mode for a short time, install pressure gauges on the gauge ports of the discharge and suction line valves. Check the suction and discharge pressures and compare them to the normal operating pressures provided in the unit's **SERVICE FACTS**.

Voltage

With the compressor operating, check the line voltage at the unit. The voltage should be within the range shown on the unit nameplate. If low voltage is encountered, check the size and length of the supply line from the main disconnect to the unit. The line may be undersized for the length of the run.

Cooling Shut Down

- Place the system selector switch in the **OFF** position or reset the thermostat at a setting above the room temperature.
- Do not de-energize the main power disconnect except when the unit is to be serviced. Power is required to keep the compressor crankcase heat (if equipped) energized and boil off refrigerant in the compressor.

Starting the Unit in the Heating Mode

NOTE: See the section on "Sequence of Operation" for a description of the heating operating sequence.

- Check to make sure that all grilles and registers are open and all unit access doors are closed before start-up.
- To start the unit in the heating mode, set the thermostat system switch to **HEAT**. Move the thermostat **HEAT** indicator to a setting above room temperature and place the fan switch in the **AUTO** or **ON** positions. The indoor fan motor will operate automatically.
- The thermostat must provide a "G" signal for fan operation. If using an auto changeover thermostat, see Figures 5 and 6 for the appropriate connections.

Heating Shut-Down

- Place the system selector switch to the **OFF** position or place the heating selector lever at a setting below the room temperature.

TROUBLESHOOTING CHART

SYSTEM FAULTS	TROUBLESHOOTING CHART																		
	HIGH VOLTAGE POWER SUPPLY	LOW VOLTAGE WIRING	START RUN COMP. IOL	START CAPACITOR	CONTROL START CONTACTOR	CONTROL VOLTAGE WIRING	CONTROL TRANSFORMER	LOW VOLTAGE WIRING	STUCK COMPRESSOR COIL	INEFFICIENT COMPRESSOR	REFRIGERANT UNDERCHARGE	EXCESSIVE EVAP. LOAD	NONCONDENSABLES	O.D. AIR RECIRCULATION	RESTRICTED O.D. AIRFLOW	TXV STUCK OPEN	REF. CIRCUIT RESTRICTIONS	I.D. AIRFLOW SUPERHEAT	
REFRIGERANT CIRCUIT																			
Liquid Pressure Too high																P	S	P	S
Liquid Pressure Too Low											S	P						S	S
Suction Pressure Too High											S	P	P					S	P
Suction Pressure Too Low												S						S	P
Liquid Refrigerant floodback (TXV System)																		S	S
Liquid Refrig. floodback (Cap. Tube System)														P			S	S	
I. D. Coil Frosting														P					P
Compressor Runs Inadequate or No Cooling											S	P		P	S			S	P
ELECTRICAL																			
Compressor & O.D. fan Do Not Start	P	P						S	P	P	P								
Compressor Will Not Start But O.D. Fan Runs	P	S	P	P	P						S								
O.D. Fan Won't Start	P		P																
Compressor Hums But Will Not Start	P		P	P	P	S					S								
Compressor Cycles on IOL	P	S	P	P	P	S					P	S	P	S	S		S		S
I.D. Blower Won't Start	P	S						S	P	P									

P-PRIMARY CAUSES S-SECONDARY CAUSES

X664390

Maintenance

Routine Maintenance by Owner

You can do some of the periodic maintenance functions for your TCH unit yourself. These functions include replacing the disposable or cleaning the permanent air filters, cleaning the unit's cabinet, cleaning the condenser coil, and conducting a general inspection of the unit on a regular basis.

⚠ WARNING: TO PREVENT INJURY OR DEATH DUE TO ELECTRICAL SHOCK OR CONTACT WITH MOVING PARTS. LOCK UNIT DISCONNECT SWITCH IN OPEN POSITION BEFORE SERVICING UNIT.

Air Filters

It is very important to keep the central duct system air filters clean. Be sure to inspect them at least once each month when the system is in constant operation. In new construction, check the filters every week for the first four (4) weeks.

- If you have disposable-type filters, replace them with new filters of the same type and size. Do not try to clean disposable filters.
- Clean permanent-type filters by washing them with a mild detergent and water. Make sure that the filters are thoroughly dry before re-installing them in the unit.
- Replace permanent filters annually if washing fails to clean them or if they show signs of deterioration. Use the same type and size as was originally installed.

Outdoor Coil

Unfiltered air circulated through the unit's outdoor coil can cause the coil's surface to become clogged with dust, dirt, etc. To clean the coil, stroke the coil surface with a soft-bristled brush vertically, that is, in the direction of the fins.

- Be sure to keep all vegetation away from the outdoor coil area.

Maintenance Performed by Serviceman

To keep your unit operating as designed, the manufacturer recommends that a qualified serviceman check over the entire system at least once each year as well as any other time that you feel that one is needed. Your serviceman should examine and inspect:

- filters (for cleaning or replacement)
- motors and drive system components
- condenser coils (for cleaning)
- safety controls (for mechanical cleaning)
- electrical components and wiring (for possible replacement and/or connection tightness)
- condensate drain (for cleaning)

In addition, your serviceman should inspect:

- unit duct connections to see that they are physically sound and sealed to the unit casing
- unit mounting support to see that it is sound
- unit to see that there is no obvious unit deterioration.

The following warning complies with State of California law, Proposition 65.

⚠ WARNING: This product contains fiberglass wool insulation! Fiberglass dust and ceramic fibers are believed by the State of California to cause cancer through inhalation. Glasswool fibers may also cause respiratory, skin, or eye irritation.

PRECAUTIONARY MEASURES

- Avoid breathing fiberglass dust.
- Use a NIOSH approved dust/mist respirator.
- Avoid contact with the skin or eyes. Wear long-sleeved, loose-fitting clothing, gloves, and eye protection.
- Wash clothes separately from other clothing: rinse washer thoroughly.
- Operations such as sawing, blowing, tear-out, and spraying may generate fiber concentrations requiring additional respiratory protection. Use the appropriate NIOSH approved respirator in these situations.

FIRST AID MEASURES

- Eye Contact** - Flush eyes with water to remove dust. If symptoms persist, seek medical attention.
- Skin Contact** - Wash affected areas gently with soap and warm water after handling.

Important Product Information

Registering your products helps provide you with one of the strongest manufacturer limited warranties available. To register, go to the manufacturer's website or contact your dealer. You will need the serial number, model number, and installation date for each product being registered. Your dealer may have included these on your invoice or can provide a list for you to use. Please take a few moments to record the following information to ensure your product registration process is quick and easy:

Packaged Unit Serial Number _____

Packaged Unit Model Number _____

Date of Installation _____

Dealer _____

Service Information

Call your installing dealer if the unit is inoperative. Before you call, always check the following to be sure service is required:

- a. Be sure the main switch that supplies power to the unit is in the ON position.
- b. Replace any burned-out fuses or reset circuit breakers.
- c. Be sure the thermostat is properly set.

Service Phone _____

**Base Limited Warranty
Packaged Air Conditioner and Packaged Heat Pump
TCK, TCH, WCK, WCH (Parts Only)
Models Less Than 20 Tons for Residential Use***

This limited warranty is provided by the manufacturer to the original purchaser and to any succeeding owner of the real property to which the Packaged Air Conditioner or Packaged Heat Pump (packaged unit) is originally affixed, and applies to products purchased and retained for use within the U.S.A. and Canada.

Beginning on January 1, 2010, R-22 refrigerant will no longer be used as a manufacturer-installed refrigerant as required by federal regulation. Following this date, depending on the availability of any remaining R-22 equipment, packaged unit model replacements may require that the entire system be R-410A compatible. Packaged units and possibly connecting line sets would need to be replaced in order to be compatible with R-410A refrigerant. Expenses associated with replacing system components that are not R-410A compatible will not be covered by the terms and conditions of the limited warranty.

The limited warranty period begins when installation is complete and the packaged unit start-up procedure has been properly completed, verified by installer's invoice or similar document. If installation completion and start-up date cannot be verified by installer's invoice or similar document, this limited warranty coverage begins six (6) months after the date of manufacture based on the packaged unit serial number.

If the sealed motor compressor fails or the outdoor coil becomes defective, or any functional part of your packaged unit fails because of manufacturing defect, within five (5) years from the date the limited warranty period begins, Warrantor will furnish without charge the required replacement compressor, coil, or functional part. Any other costs, such as local transportation, related service labor, diagnosis calls, refrigerant and related items are not included.

This limited warranty does not apply if the packaged unit was purchased direct (i.e. from internet websites or auctions) on an uninstalled basis. Additionally, this limited warranty will not apply unless the packaged unit is: (1) installed by a licensed or qualified HVAC technician, (2) applied and installed in accordance with the manufacturer's recommendations and its Installer's guide and (3) in compliance with all industry standards, national, state and local codes.

This limited warranty does not cover failure of your packaged unit if it is damaged while in your possession; including, but not limited to (1) damage caused by unreasonable use, (2) damage from failure to properly maintain as set forth in the Use and Care manual or Installer's Guide, (3) damage that is not considered a manufacturing defect, such as acts of God, malfunctions or failures resulting from fire, water, storms, lightning, earthquake, theft, riot, misuse, abuse, increased utility usage costs, or (4) performance problems due to improper selection/equipment match, installation or application.

This limited warranty applies to product installed on or after 5/1/2009.

THE LIMITED WARRANTY AND LIABILITY SET FORTH HEREIN ARE IN LIEU OF ALL OTHER WARRANTIES AND LIABILITIES, WHETHER IN CONTRACT OR IN NEGLIGENCE, EXPRESS OR IMPLIED, IN LAW OR IN FACT, INCLUDING BUT NOT SPECIFICALLY LIMITED TO IMPLIED WARRANTIES OF MERCHANTABILITY AND FITNESS FOR PARTICULAR USE, AND IN NO EVENT SHALL WARRANTOR BE LIABLE FOR ANY INCIDENTAL OR CONSEQUENTIAL DAMAGES.

Some states and provinces do not allow limitations on how long an implied limited warranty lasts or do not allow the exclusion or limitation of incidental or conse-quential damages, so the above limitation or exclusion may not apply to you. This limited warranty gives you specific legal rights, and you may also have other rights which vary by jurisdiction.

Parts will be provided by our factory organization through an authorized service organization in your area listed in the yellow pages.

If you wish further help or information concerning this limited warranty, contact:

Residential Systems
6200 Troup Highway, Tyler, TX 75707
Attention: Customer Relations

TW-1048-1409

* This limited warranty is for residential usage of this equipment and not applicable when this equipment is used for a commercial application.

A commercial use is any application where the end purchaser uses the product for other than personal, family or household purposes.



Limited Warranty Central Air Conditioner 4TCY4, 4TCC3, 4TCX3, TCD, TCH, TCK, THC and TSC (Parts Only)

Models Less Than 20 Tons for Commercial Use*

This limited warranty is extended by the manufacturer to the original purchaser and to any succeeding owner of the real property to which the Air Conditioner is originally affixed, and applies to products purchased and retained for use within the U.S.A. and Canada. There is no warranty against corrosion, erosion or deterioration.

Beginning on January 1, 2010, R-22 refrigerant will no longer be used as a manufacturer-installed refrigerant as required by federal regulation. Following this date, depending on the availability of any remaining R-22 equipment, packaged unit model replacements may require that the entire system be R-410A compatible. Packaged units and possibly connecting line sets would need to be replaced in order to be compatible with R-410A refrigerant. Expenses associated with replacing system components that are not R-410A compatible will not be covered by the terms and conditions of the limited warranty.

The limited warranty period begins when installation is complete and the packaged unit start-up procedure has been properly completed, verified by installer's invoice or similar document. If installation completion and start-up date cannot be verified by installer's invoice or similar document, limited warranty coverage begins six (6) months after the date of manufacture based on the packaged unit serial number.

If any part of your Air Conditioner fails because of a manufacturing defect within one year from the date the limited warranty period begins, Warrantor will furnish without charge the required replacement part.

In addition, if the sealed motor-compressor fails because of a manufacturing defect within the second through fifth year from the date the limited warranty period begins, Warrantor will furnish without charge the required replacement compressor. Warrantor's obligations and liabilities under this warranty are limited to furnishing F.O.B. Warrantor factory or warehouse replacement parts for Warrantor's products covered under this warranty. Warrantor shall not be obligated to pay for the cost of lost refrigerant. No liability shall attach to Warrantor until products have been paid for and then liability shall be limited solely to the purchase price of the equipment under warranty shown to be defective.

This limited warranty does not apply if the packaged unit was purchased direct (i.e. from internet websites or auctions) on an uninstalled basis. Additionally, this limited warranty will not apply unless the packaged unit is: (1) installed by a licensed or qualified HVAC technician, (2) applied and installed in accordance with the manufacturer's recommendations and its Installer's guide and (3) in compliance with all industry standards, national, state and local codes.

This limited warranty does not cover failure of your packaged unit if it is damaged while in your possession; including, but not limited to (1) damage caused by unreasonable use, (2) damage from failure to properly maintain as set forth in the Use and Care manual or Installer's Guide (refer to "Proper Maintenance" section), (3) damage that is not considered a manufacturing defect, such as acts of God, malfunctions or failures resulting from fire, water, storms, lightning, earthquake, faulty power supply or power surges, corrosive environments, insect or vermin infestation, theft, riot, misuse, abuse, increased utility usage costs, or (4) performance problems due to improper selection / equipment match-up, installation or application.

THE LIMITED WARRANTY AND LIABILITY SET FORTH HEREIN ARE IN LIEU OF ALL OTHER WARRANTIES AND LIABILITIES, WHETHER IN CONTRACT OR IN NEGLIGENCE, EXPRESS OR IMPLIED, IN LAW OR IN FACT, INCLUDING BUT NOT SPECIFICALLY LIMITED TO IMPLIED WARRANTIES OF MERCHANTABILITY AND FITNESS FOR PARTICULAR USE, AND IN NO EVENT SHALL WARRANTOR BE LIABLE FOR ANY INCIDENTAL OR CONSEQUENTIAL DAMAGES.

Some states do not allow limitations on how long an implied warranty lasts or do not allow the exclusion or limitation of incidental or consequential damages, so the above limitation or exclusion may not apply to you.

This warranty gives you specific legal rights, and you may also have other rights which vary from state to state.

Residential Systems
6200 Troup Highway, Tyler, TX 75707
Attention: Consumer Relations

Or visit our website: www.trane.com/residential

TW-1001-3308

* This warranty is for commercial usage of said equipment and not applicable when the equipment is used for a residential application. Commercial use is any application where the end purchaser uses the product for other than personal, family or household purposes.

Ref: 9/10/08 4:00 pm

The limited warranties displayed in this publication and/or on ComfortSite™ may not accurately reflect the actual limited warranty that shipped with the product.