

TRANE		FILE NUMBER:	DRAWING NUMBER:	SHEET:	REV
THIS DRAWING IS PROPRIETARY AND SHALL NOT BE COPIED OR ITS CONTENTS DISCLOSED TO ANY OTHER PARTIES WITHOUT THE CONSENT OF TRANE.		2313-0461	1 OF 1	A	
DRAWN BY:	TRANE DATE:	ODYSSEY			
B. WALDEN	06-FEB-12	DIAGRAM			
REPLACES:	REVISION DATE:	CONNECTION - HEAT PUMP - R22 DRY SHIP			
--	--	7.5T (ALL VOLTAGES) &			
CAD SYSTEM USED:	SIMILAR TO:	10T 460/60HZ			
Pro/DETAIL	2313-0419				

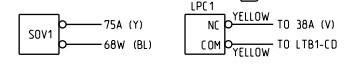
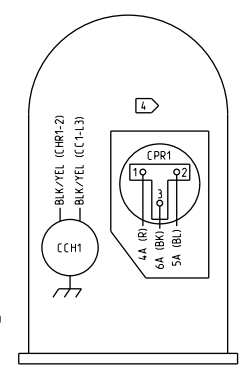
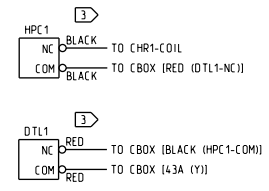
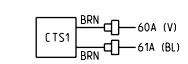
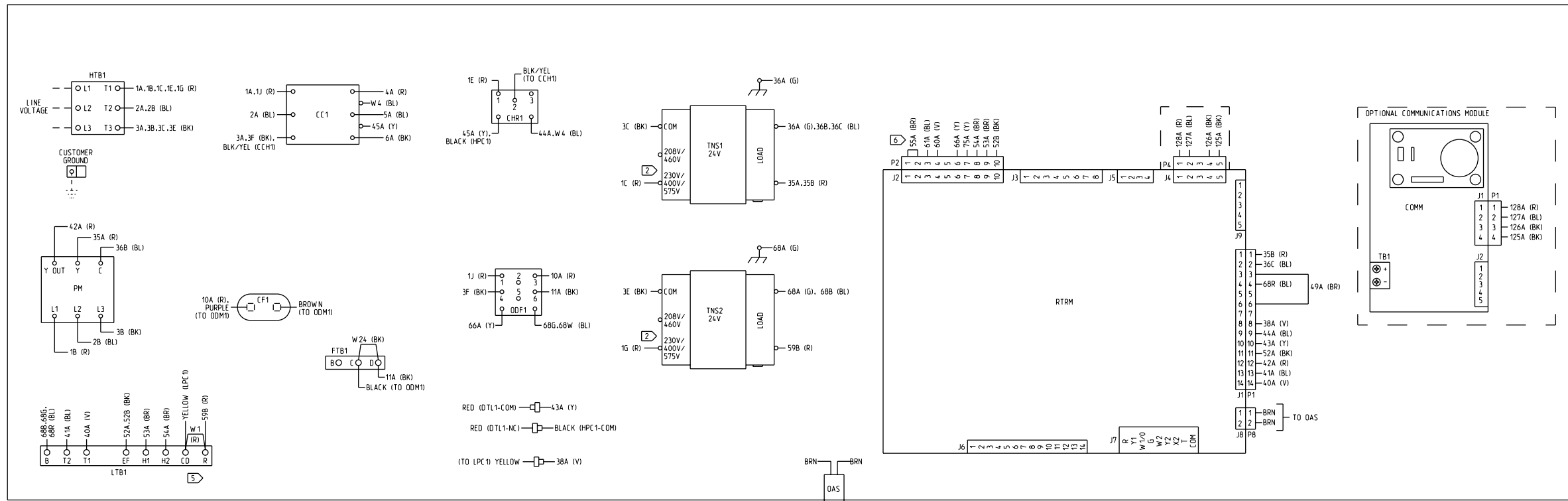
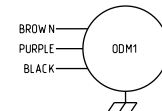

- NOTES:
- DASHED LINES INDICATE RECOMMENDED FIELD WIRING BY OTHERS. DASHED LINE ENCLOSURES AND/OR DASHED DEVICE OUTLINES INDICATE COMPONENTS PROVIDED BY THE FIELD. PHANTOM LINE ENCLOSURES INDICATE ALTERNATE CIRCUITRY OR AVAILABLE SALES OPTIONS. SOLID LINE INDICATES WIRING BY TRANE CO.
 - CONNECTIONS SHOWN ARE FOR 230V/60HZ/3PH. WHEN 208V/460V/60HZ/3PH OPERATION IS REQUIRED, MOVE WIRES 1C (R) AND 1G (R) FROM 230V TERMINAL OF TNS1 AND TNS2 TO 208V TERMINAL.
 - CAUTION: DO NOT JUMPER ACROSS SWITCHES DTL1, LPC1, AND HPC1 UNDER ANY CIRCUMSTANCES.
 - NOTICE: DO NOT OPERATE OR APPLY POWER TO COMPRESSORS WHILE UNDER A VACUUM. FAILURE TO FOLLOW THESE INSTRUCTIONS WILL RESULT IN COMPRESSOR FAILURE.
 - IF EVAPORATOR DEFROST CONTROL (EDC) IS USED ON INDOOR UNIT, REMOVE JUMPER WIRE W1 (R) BETWEEN TERMINALS "CD" AND "R" ON LTB1.
 - TO ENABLE ELECTRIC HEAT, CUT WIRE 55A (BR) ON P2.

DEVICE	DESCRIPTION
CC1	COMPRESSOR CONTACTOR
CCH1	CRANKCASE HEATER
CF1	OUTDOOR FAN CAPACITOR
CHR1	CRANKCASE HEATER RELAY
COMM	COMMUNICATION INTERFACE MODULE
CPR1	COMPRESSOR
CTS1	COIL TEMPERATURE SENSOR
DTL1	DISCHARGE TEMPERATURE LIMIT
FTB1	FAN TERMINAL BLOCK
HPC1	HIGH PRESSURE CUTOUT
HTB1	HIGH VOLTAGE TERMINAL BLOCK
LPC1	LOW PRESSURE CUTOUT
LTB1	LOW VOLTAGE TERMINAL BLOCK
OAS	OUTDOOR AIR TEMP SENSOR
ODF1	OUTDOOR FAN CONTACTOR
ODM1	OUTDOOR FAN MOTOR
PM	PHASE MONITOR
RTRM	ROOFTOP MODULE
SOV1	SWITCH-OVER VALVE
TNS1, TNS2	TRANSFORMER - CONTROL

WIRE COLOR DESIGNATION			
ABBR	COLOR	ABBR	COLOR
BL	BLUE	O	ORANGE
BK	BLACK	R	RED
BR	BROWN	V	VIOLET (PURPLE)
G	GREEN	W	WHITE
GY	GRAY (SLATE)	Y	YELLOW