

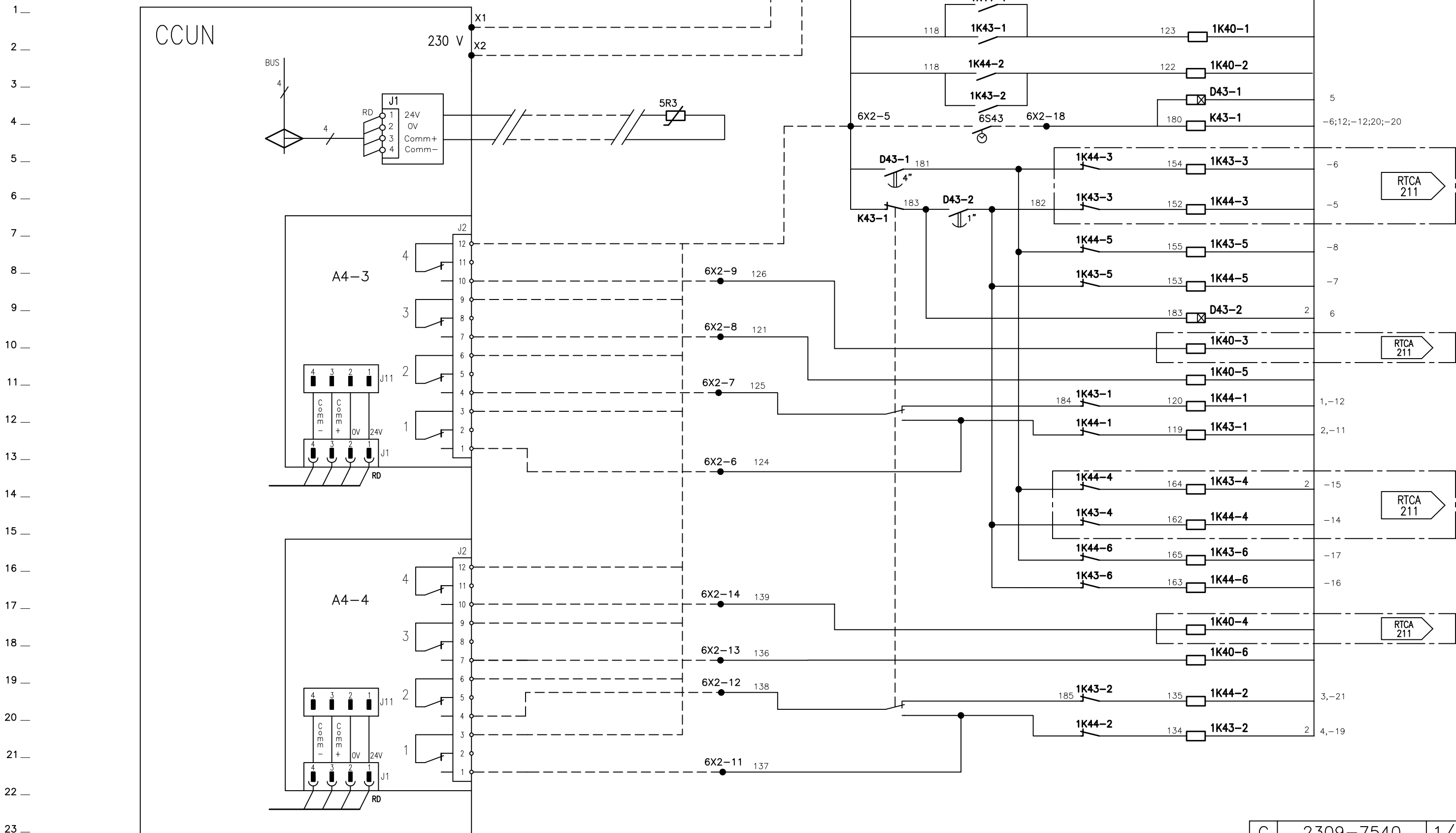

RTCA 208-209-211

C	2309-7540	1/2
Date: 04/10/06		Rev. /
CAO	Std	

SCHEMA ELECTRIQUE	SCHEMA ELETTRICO
VERDRÄHTUNGSCHEMA	STROOMKRINSHEMA
WIRING DIAGRAM	ESQUEMA ELECTRICO





RTCA 208-209-211

C 2309-7540 2/2
Date: 04/10/06 Rev. /
CAO Std

SCHEMA PUISSANCE	SCHEMA DI POTENZA
ANSCHLUSSPLAN	HOOFDSTROOMSCHEMA
POWER DIAGRAM	ESQUEMA DE REGULACION

———	CABLAGE TRANE	TRANE VERDRÄHTUNG	TRANE WIRING
---	CABLAGE CLIENT	VERDRÄHTUNG DURCH KUNDEN	CUSTOMER WIRING
———	CABLAGGIO TRANE	BEDRADING DOOR TRANE	CABLEADO TRANE
---	CABLAGGIO CLIENTE	BEDRADING DOOR KLANT	CABLEADO DEL CLIENTE

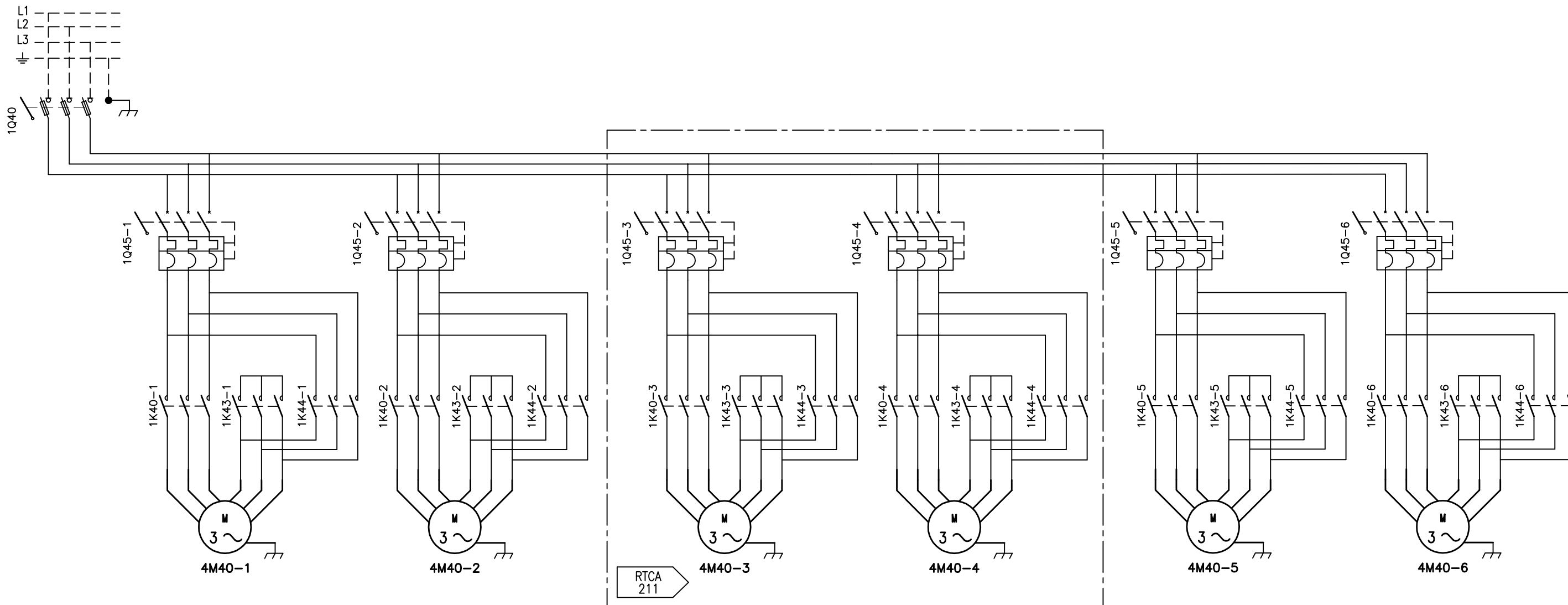

ITEM	FRANCAIS	DEUTSCH	ENGLISH
1K40	CONTACTEUR MARCHE VENTILATEUR	SCHUETZ , BETRIEB VENTILATOR	FAN RUN CONTACTOR
1K43	CONTACTEUR ETOILE VENTILATEUR	SCHUETZ, STERN VENTILATOR	START FAN CONTACTOR
1K44	CONTACTEUR TRIANGLE VENTILATEUR	SCHUETZ, DREIECK VENTILATOR	DELTA FAN CONTACTOR
1Q40	INTERRUPTEUR SECTIONNEUR VENTIL.	TRENNER, VENTILATOR	FAN DISCONNECT SWITCH
1Q45	DISJONCTEUR MOTEUR VENTIL. CDS	SCHUTZSCHALTER, VENTIL. VERFL.	CDS FAN MOTOR CIRCUIT BREAKER
4M40	MOTEUR VENTILATEUR	MOTOR VENTILATOR	FAN MOTOR
6X...	BORNES CLIENT	KLEMMEN, KUNDE	CUSTOMERS TERMINALS
D43...	MINUTERIE	ZEITMEISSER	TIMER
K43...	RELAJ	STAFFEL	RELAY

ITEM	ITALIANO	NEDERLANDS	ESPAÑOL
1K40	CONTATTORE FUNZION. VENTILATORE	VENTILATOR MAGNEETSCHAKELAAR	CONTACTOR MARCHA VENTILADOR
1K43	CONTATTORE A STELLA VENTILAT.	STERSCHAKELAAR	CONTACTOR ESTRELLA VENTILADOR
1K44	CONTATTORE TRIANG. VENTILAT.	DRIEHOEKSCHAKELAAR	CONTACTOR TRIANGULO VENTILADOR
1Q40	SEZIONATORE VENTILATORE	VENTILATORSCHAKELAAR	INTERRUPTOR VENTILADOR
1Q45	INTERR. MOTORE VENT. COND.	INSTALLATIEAUTOMAAT COND. VENTIL.	SECCIONADOR MOTOR VENTIL. COND.
4M40	MOTORE VENTILATORE CONDENSATORE	CONDENSORVENTILATORMOTOR	MOTOR VENTILADOR CONDENSADOR
6X	MORSETTO TERMINALE REGOLAZIONE	STUURSTROOM KLEMMENSTROOK	REGLETA CONEXIONES FUERZA
D43...	CONTAMINUTI	TIMER	CONTADOR DE TIEMPO
K43...	RELE	AFLOSSING	ENLACE

