

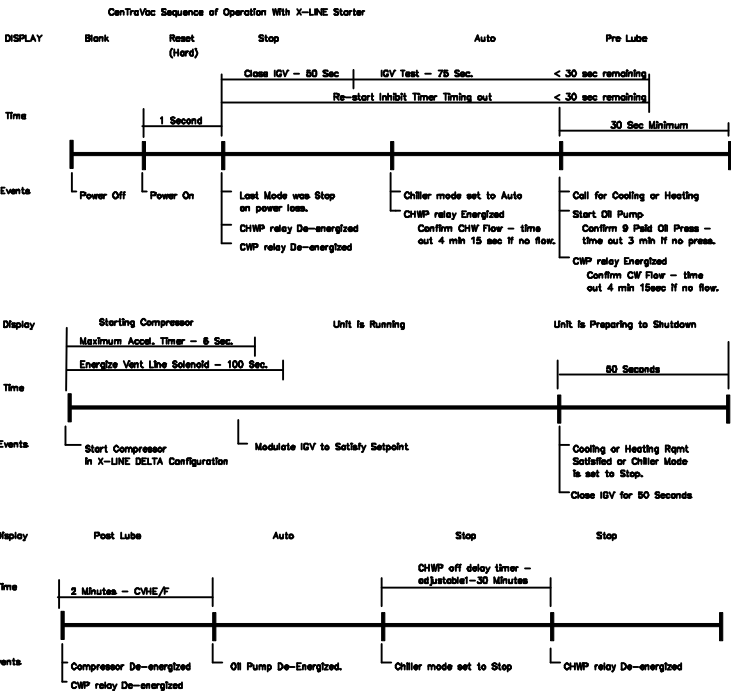

HERMETIC CENTRIFUGAL LIQUID CHILLER

CENTRAVAC[®]
UCP2 SCHEMATIC WIRING CVHE, CVHF, CVHG
REMOTE ACCROSS THE LINE STARTER

DRAWING NUMBER
2307-5201
REV
A

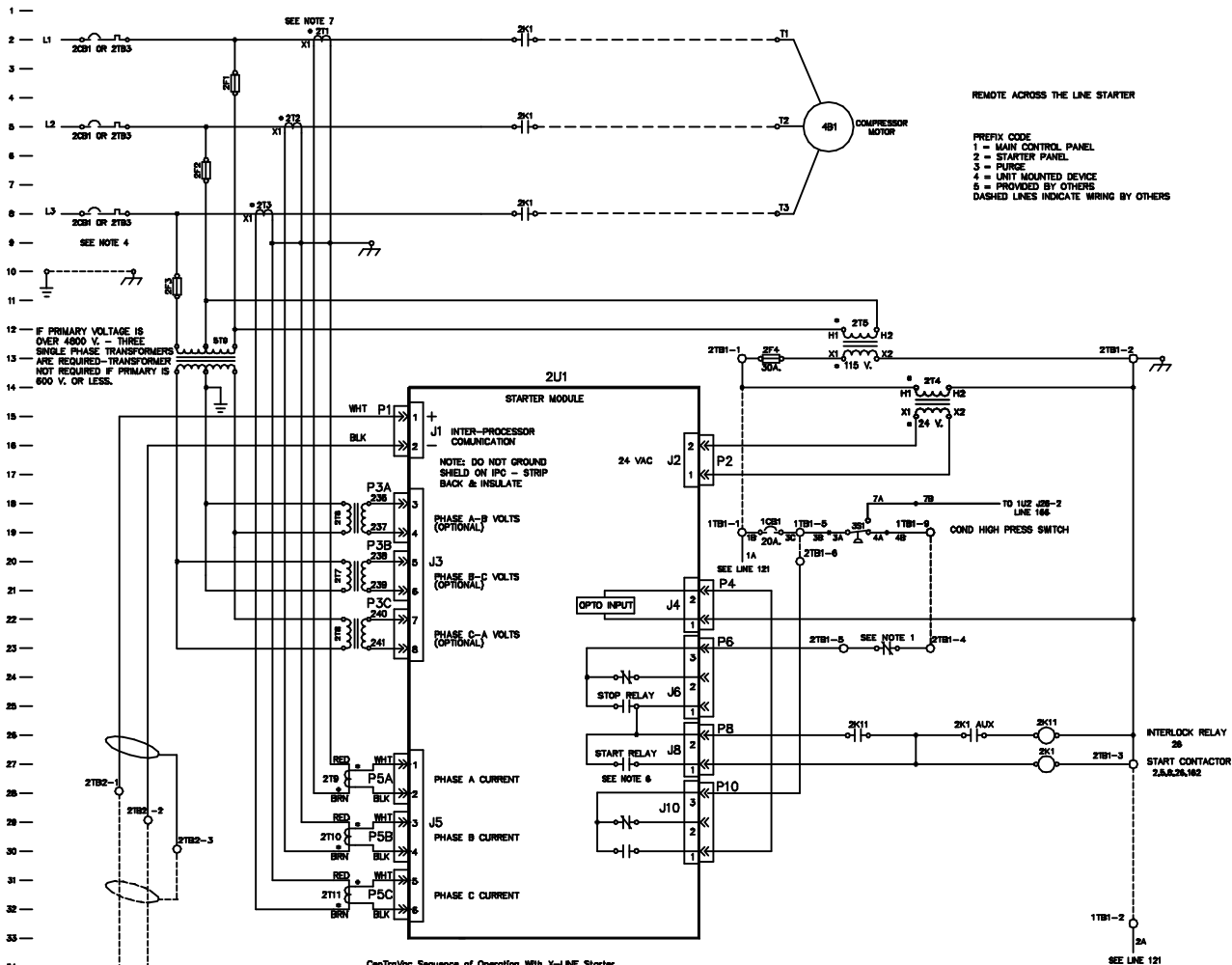

- NOTES:
- OPTIONAL STARTER INTERLOCK. SEE STARTER MANUFACTURER'S WIRING DIAGRAM FOR SPECIFIC APPLICATION.
 - UNLESS OTHERWISE NOTED, ALL SWITCHES ARE SHOWN AT 25 C (77 F), AT ATMOSPHERIC PRESSURE, AT 50% RELATIVE HUMIDITY, WITH ALL UTILITIES TURNED OFF AND AFTER A NORMAL SHUTDOWN HAS OCCURRED.
 - NUMBERS ALONG THE RIGHT SIDE OF THE SCHEMATIC DESIGNATE THE LOCATION OF THE CONTACTS BY LINE NUMBER. AN UNDERLINED NUMBER INDICATES A NORMALLY CLOSED CONTACT.
 - THREE PHASE POWER SUPPLY VOLTAGE-SEE UNIT NAMEPLATE.
 - REMOTE ACROSS THE LINE STARTER WIRING BETWEEN STARTER AND STARTER MODULE ARE SHOWN. SEE STARTER MANUFACTURER'S WIRING DIAGRAM FOR SPECIFIC STARTER WIRING.
 - RELAY COILS ARE NOT SHOWN. CONTACTS ARE CONTROLLED BY THE LOGIC OF THE MICRO-CONTROLLER. SEE SEQUENCE OF OPERATION.
 - POLARITY MARKING ON THE CURRENT TRANSFORMER, (H1 MARKING ON C1) MUST BE FACING TOWARDS THE INCOMING CURRENT.

WARNING
HAZARDOUS VOLTAGE!
DISCONNECT ALL ELECTRIC POWER INCLUDING REMOTE DISCONNECTS BEFORE SERVICING.
FAILURE TO DISCONNECT POWER BEFORE SERVICING CAN CAUSE SEVERE PERSONAL INJURY OR DEATH.

AVERTISSEMENT
VOLTAGE HAZARDEUX!
DISCONNECTEZ TOUTES LES SOURCES ELECTRIQUES INCLUANT LES DISCONNECTS REMOTE AVANT D'Effectuer L'ENTRETIEN.
FAUTE DE DECONNECTER LA SOURCE ELECTRIQUE AVANT D'Effectuer L'ENTRETIEN PEUT ENTRAINER DES BLESSURES CORPORELLES SEVERES OU LA MORT.

CAUTION
USE COPPER CONDUCTORS ONLY.
UNIT TERMINALS ARE NOT DESIGNED TO ACCEPT OTHER TYPES OF CONDUCTORS.
FAILURE TO DO SO MAY CAUSE DAMAGE TO THE EQUIPMENT.

THIS DRAWING IS PROPRIETARY AND SHALL NOT BE COPIED OR ITS CONTENTS DISCLOSED TO OUTSIDE PARTIES WITHOUT THE WRITTEN CONSENT OF THE TRANE COMPANY