



The Thermostat Leader — One Brand for Every Application, Budget, and Customer.



TRANE®

HVAC Parts & Supplies

The Thermostat Leader

It is difficult to top Honeywell's decades of experience, and our place in millions of homes and buildings – we make the world more comfortable. From the basics to the ultimate in touchscreen programmable technology, Honeywell offers a full line of quality thermostats to meet your needs for every application, budget, and customer. When comfort counts, count on Honeywell.



Honeywell is the #1 choice of homeowners

Better Products Mean Better Business.

Quality engineering and customer satisfaction are a powerful combination. Honeywell's unwavering commitment to our customers includes an intense focus on the measurement of product quality to deliver reliable products with the newest available features at the right price.



Honeywell's quality testing includes subjecting our thermostats to extreme vibrations and temperatures to make sure that they're built to last

One Brand For Every Application, Budget, and Customer.

Only one brand provides you a full line of thermostats with universal compatibility for every application.



Honeywell uses Six Sigma in our design and manufacturing processes to ensure reliability.

Commercial

Honeywell thermostats provide support for many different commercial applications. Whether a school needs to conserve energy by adding thermostats with holiday scheduling and temporary override or restaurants require tighter temperature control and integrated ventilation control (economizer required), you'll find a thermostat for your application.

Residential

Today's consumers demand much more from their home comfort controls than they did a half century ago, and Honeywell technology is still the benchmark.

Why Honeywell? When it comes to comfort control, Honeywell is the #1 choice of homeowners – not only because our thermostats are easy to use, but also because they're built to last.

Contact Info

Technical Support Numbers

• Residential	1-800-468-1502
• Commercial Components	763-954-6464
• Residential Zoning	1-800-828-8367
• TrueSTEAM™	1-800-814-9452
• Water Products	401-738-4290
• Exclusive Technical Support for Contractor PRO members Have account number ready	1-877-880-3383





Web Sites

<http://customer.honeywell.com>

• Contractor PRO Program	www.contractorpro.com
• New Product Information (Commercial)	www.beyondinnovation.honeywell.com
• New Product Information (Residential)	www.forwardthinking.honeywell.com
• Technical and Sales Literature	http://customer.honeywell.com



Honeywell Programmable Thermostat Cross-Reference Chart

	MODEL		SCHEDULE OPTIONS				USER INTERFACE	APPLICATION					
	Mnemonic Number	HONEYWELL OS Number	Program Options	ENERGY STAR®	Temporary Override	Holiday		Conventional	Heat Pump	Modulating	Fan Coil	PTAC	
	Conventional/ Heat Pump	THT02597	T7350D1008	365-Day	•	•	•	Soft Keys	3 Heat / 3 Cool or 2 Heat / 4 Cool	3 Heat / 2 Cool			
		THT02568	T7350B1002	365-Day	•	•	•	Soft Keys	3 Heat / 2 Cool or 2 Heat / 3 Cool	3 Heat / 2 Cool			
		THT02588	T7350A1004	365-Day	•	•	•	Soft Keys	1 Heat / 2 Cool or 2 Heat / 1 Cool	2 Heat / 1 Cool			
		THT02589	T7350M1008	365-Day	•	•	•	Soft Keys			Two 4-20 mA		
	Conventional/ Heat Pump	THT02688	T7351F2010	365-Day	•	•	•	Soft Keys	3 Heat / 3 Cool or 2 Heat / 4 Cool	3 Heat / 2 Cool			
	Commercial VisionPRO® 8000	THT02519	TB8220U1003	7-Day	•	Cumulative	•	Touchscreen	2 Heat / 2 Cool	3 Heat / 2 Cool			
	CommercialPRO® 7000	THT02572	TB7220U1012	7-Day	•	Cumulative	•	Soft Keys	2 Heat / 2 Cool	3 Heat / 2 Cool			
	MultiPRO™	THT02768	TB7100A1000	7-Day	•	Cumulative	•	Soft Keys	1 Heat / 1 Cool	2 Heat / 1 Cool		2 or 4-pipe	2 Heat / 1 Cool

POWER METHOD	FEATURES AND FUNCTIONS								DISPLAY INFORMATION			COMPETITIVE CROSS REFERENCE			
	Real-Time Clock (Automatically Updates Daylight Savings)	Permanent Memory Retention	Recovery Ramps	Economizer Output	Multiple Keypad Lockout Levels	Dehumidification Control	Remote Sensing	Display Size (Viewable)	On-Demand Backlighting	Continuous Backlighting	Simultaneous Display of Room and Set Temperature	White-Rodgers	Invensys/Robertshaw	Carrier/Totaline	TCS/basys Controls
24 VAC	•	•	•	•	3	•	Indoor, Outdoor, Discharge, Humidity, Occupancy	4.2 sq. in.		•		All White-Rodgers Thermostats	All Invensys/Robertshaw Thermostats	All Carrier/Totaline Thermostats	SZ1022, SZ1024, SZ1031, SZ1033, SZ1035, SZ1009
24 VAC	•	•	•	•	3		Indoor, Outdoor, Discharge	4.2 sq. in.		•		All White-Rodgers Thermostats	9700i Series, 300 Series	All Carrier/Totaline Thermostats	SZ1022, SZ1024, SZ1031, SZ1033, SZ1009
24 VAC	•	•	•	•	3			4.2 sq. in.		•		1-F90-371, 1-F97-371, 1-F96-344, 1-F90-374, 1-F97-374	9700i, 9701i		SZ1009
24 VAC	•	•	•	•	3	•	Indoor, Outdoor, Discharge, Humidity, Occupancy	4.2 sq. in.		•					SZ1017a, SZ1053
24 VAC	•	•	•	•	4	•	Indoor, Outdoor, Discharge, Humidity, Occupancy	4.2 sq. in.		•		All White-Rodgers Thermostats	All Invensys/Robertshaw Thermostats	All Carrier/Totaline Thermostats	SZ1022, SZ1024, SZ1031, SZ1033, SZ1035, SZ1009
24 VAC or Battery	•	•	•	•	4		Indoor or Outdoor	10 sq. in.	•	•	•	IF90 Series, IF80 Series	9800 Series, 9700i Series, 300 Series	P374-2100, P374-2200, P374-2300, 33S250-01, 33CS220-01, 33CS071-01, 33CSSP2-WC, 33CSSN2-WC	
24 VAC or Battery	•	•	•	•	4		Indoor or Outdoor	4 sq. in.	•	•	•	IF90 Series, IF80 Series	9800 Series, 9700i Series, 300 Series	P374-2100, P374-2200, P374-2300, 33S250-01, 33CS220-01, 33CS071-01, 33CSSP2-WC, 33CSSN2-WC	
24 VAC or Battery	•	•	•		5		Indoor and Occupancy	4 sq. in.	•	•	•	IF90-371, IF96-344, IF97-371, IF80-224, IF80-241, IF80-261, IF86-244, IF87-251, IF82-261, IF89-211	97012, 9610, 9700i, 300-224, 300-225, 300-226,	P274-0100, P274-1100, P374-0200, P374-0300	SZ1-61, SZ1062

COMMERCIAL

Commercial Programmable Thermostats



T7350A, B, D, M

Standalone Staged and Modulating Thermostats

- **Integrated humidity sensor (T7350D)**
 - Several strategies for dehumidifying
- **365-Day Schedule**
 - Schedule holidays throughout the year to save energy
- **Remote sensing (T7350B, D and M)**
 - Indoor, outdoor, humidity, occupancy and discharge air sensors available for added flexibility
 - Outdoor Air and Discharge Air Temperature Lockout
- **Controls conventional or heat pump systems**
- **Flexibility allows the same thermostat to be used on every top roof unit in the system**
- **PID loop**
 - First thermostat with configurable PID loop

Mnemonic Number	HONEYWELL OS Number	Description	Application
THT02588	T7350A1004	T7350 Commercial Programmable Thermostat	T7350A1004: 1 Heat/2 Cool and 2 Heat/1 Cool Conventional, 2 Heat/1 Cool Heat Pump
THT02568	T7350B1002		T7350B1002: 3 Heat/2 Cool and 2 Heat/3 Cool Conventional, 3 Heat/2 Cool Heat Pump
THT02597	T7350D1008		T7350D1008: 3 Heat/3 Cool and 2 Heat/4 Cool Conventional, or 3 Heat/2 Cool Heat Pump with 2 Auxiliary Stages, Advanced Dehumidification and Occupancy Option
THT02589	T7350M1008	Modulating Commercial Programmable Thermostat	<ul style="list-style-type: none"> – Two 4-20 mA Outputs for Modulating Applications – Two Relays for Staged Control – Advanced Dehumidification

Replacements							Sensor Compatibility
		Honeywell	White-Rodgers	Invensys/Robertshaw	Carrier/Totaline	TCS/basys Controls	
Conventional/Heat Pump	T7350A1004	All T7300s with Q7300A2008 Subbase	1-F90-371, 1-F97-371, 1-F96-344, 1-F90-374, 1-F97-374	9700i, 9701i		SZ1009	
	T7350B1002	All T7300s with Q7300A and Q3700C Subbases	All White-Rodgers Thermostats	9700i Series, 300 Series	All Carrier/Totaline Thermostats	SZ1022, SZ1024, SZ1031, SZ1033, SZ1009	T7771A1005, TR21, TR21-A (averaging), TR22, TR23, TR24, C7772A1012 (flush mount), C7770A1006 (return airduct), C7041P2004 (button sensor) WSK-24*, TR21-WK, TR23-WK
	T7350D1008	All T7300s with Non-Q7300H Subbases	All White-Rodgers Thermostats	All Invensys/Robertshaw Thermostats	All Carrier/Totaline Thermostats	SZ1022, SZ1024, SZ1031, SZ1033, SZ1035, SZ1009	
Modulating	T7350M1008					SZ1017a, SZ1053	

* Requires R822 switching relay



T7351F

Standalone Staged Thermostat

- **Keypad programming**
 - All configuration is done through the keypad
- **Integrated humidity sensor**
 - Several strategies for dehumidifying
- **365-Day Schedule**
 - Schedule holidays throughout the year to save energy
- **Remote sensing**
 - Indoor, outdoor, humidity, occupancy and discharge air sensors available for added flexibility
 - Outdoor Air and Discharge Air Temperature Lockout
- **Controls conventional or heat pump systems**
- **Flexibility allows the same thermostat to be used on every top air unit in the system**



Mnemonic Number	HONEYWELL OS Number	Description	Application
THT02688	T7351F2010	T7351 Commercial Programmable Thermostat	3 Heat/3 Cool and 2 Heat/4 Cool Conventional, or 3 Heat/2 Cool Heat Pump with 2 Auxiliary Stages, Advanced Dehumidification and Occupancy Option

Replacements						Sensor Compatibility
	Honeywell	White-Rodgers	Invensys/Robertshaw	Carrier/Totaline	TCS/basys Controls	
Conventional/Heat Pump	T7351F2010 All T7300s with Non-Q7300H Subbases	All White-Rodgers Thermostats	All Invensys/Robertshaw Thermostats	All Carrier/Totaline Thermostats	SZ1022, SZ1024, SZ1031, SZ1033, SZ1035, SZ1009	T7771A1005, TR21, TR21-A (averaging), TR22, TR23, TR24, C7772A1012 (flush mount), C7770A1006 (return airduct), C7041P2004 (button sensor) WSK-24*, TR21-WK, TR23-WK

* Requires R822 switching relay

T7350/T7351F Applications



Schools

- Up to 10 holidays can be scheduled into the Holiday Scheduler, which can be programmed to handle multiple days per holiday event, can program closed days during the summer or spring break and can be programmed for specific calendar events. (All Models)
- Dehumidification features can be used to control dew points in buildings and can be deployed where moisture is an issue, such as around school pools or in humid locations. (T7350D, M, H and T7351F)
- Temporary Override can be configured from 1 to 8 hours to allow override from unoccupied schedule to an occupied schedule as well as for classrooms that are only used for parts of the week or just occasionally used. (All Models)
- PID Algorithm is the best control algorithm available that can heat and cool large spaces, such as gymnasiums or auditoriums, quickly and accurately. The PID Algorithm is specifically tuned for oversized equipment and has a short sensor time constant that can react quickly to demand changes. (All T7350 Models)



Banks

- Easy-to-use Holiday Scheduler. (T7350B, D, M, H and T7351F)
- T7350 Palm® Software comes pre-configured with all bank holidays for easy programming into the thermostat. (All T7350 Models)



Healthcare and Gym Facilities

- Solid solution for rooftop units on facilities that demand very accurate temperature and enthalpy control. The PID Algorithm will maintain the most accurate temperature control in the facility. (All T7350 Models)
- Dehumidification features are ideal for controlling high-moisture areas. (T7350D, M, H and T7351F)



Restaurant/Food Service

- PID Commercial Algorithm provides the best comfort control to react to the constantly changing food service and restaurant environments, reacting quickly to changing load demands via fast-sensing time constants. (All T7350 Models)
- Remote Sensing configuration options allow the use of commercial 20K ohm and 10K ohm sensors to create a 20K ohm averaging network, a good solution for food service locations that have high load demands. (T7350B, D, M, H and T7351F)
- Economizer function allows restaurants to meet ventilation requirements and is also important to balance the air intake of the restaurant. Restaurants that are not properly balanced do not achieve good comfort control as they draw in unconditioned air. (All Models)



Churches/Public Worship

- PID Algorithm is the best control algorithm available that can heat and cool large spaces, such as sanctuaries and fellowship rooms, quickly and accurately. The PID Algorithm is specifically tuned for oversized equipment and has a short sensor time constant that can react quickly to demand changes. (All T7350 Models)
- T7350 Wall Modules, including the T7771, TR22, TR23 and TR24 models allow for setpoint-only adjustment with range stops, temporary override control or a combination of both to provide the end-users with flexibility to provide optimal comfort during occupied events. (T7350B, D, M, H and T7351F)



Retail

- Customizable Recovery Ramp feature guarantees the exact temperature specified when the store opens, ensuring customer and staff comfort. (All Models)
- Easy-to-use Holiday Scheduler. (All Models)
- For energy management, the T7350 Demand Limit Bump and Demand Limit Control can be programmed with communicating versions of the T7350 to provide energy savings when rooftop units can be staggered to control energy costs during peak periods. (T7350H)



Office Building Zones

- The T7350 is one of the only Honeywell thermostats that integrate with occupancy sensors for office zones that are normally unoccupied or partially occupied. (T7350D, M, H and T7351F)
- T7350 Wall Modules, including the T7771, TR22, TR23 and TR24 models allow for setpoint-only adjustment with range stops, temporary override control or a combination of both to provide the end-users with flexibility to provide optimal comfort during occupied events. (T7350B, D, M, H and T7351F)
- Customizable Recovery Ramp feature guarantees the exact temperature specified when the office opens. (All Models)

Heat Pumps

- Outdoor Air Sensor automatically turns off heat pump equipment in cold climates. The T7350 is the only Honeywell thermostat that uses both an outdoor air sensor and indoor sensors/wall modules for heat pump control applications. (T7350B, D, H and T7351F)

Equipment Protection

- Discharge Air Sensor detects abnormally high or low discharge air temperatures and shuts down equipment if limits are exceeded. (T7350B, D, M, H and T7351F)

Modulating Control — Discharge Air Control

- By tuning the PID loop, optimal control can be achieved. 20K ohm duct sensors can be used in the wall module terminals for temperature sensing. The modulating output will control the damper position. (T7350M, H)

Modulating Control – Hydronic Boilers and Pumps

- Combine modulating control and on/off relay control. The modulating output can control modulating actuator valves during the heating season and up to 2-stage conventional cooling during the cooling season. (T7350M, H)
- Ideal for split systems that have separate heating and cooling equipment and need both a modulating output and a conventional output. The fan relay can be configured for either conventional (plenum switch controls fan) or electric (thermostat energized fan on call for heat) applications. (T7350M, H)
- Various hydronic control applications are possible, including unit ventilators, fan coils or any other modulating system. The modulating outputs support both direct and reverse acting signals. (T7350M, H)



Mnemonic Number	HONEYWELL OS Number	Benefit
THT02588	T7350A1004	Energy Savings, Comfort, Fresh Air
THT02568	T7350B1002	Energy Savings, Comfort, Fresh Air
THT02597	T7350D1008	Energy Savings, Comfort, Fresh Air, Dehumidification
THT02589	T7350M1008	Energy Savings, Comfort, Fresh Air, Dehumidification, Modulating
THT02688	T7351F2010	Energy Savings, Comfort, Fresh Air, Dehumidification

Commercial Programmable Thermostats



Commercial VisionPRO® 8000

Programmable Touchscreen Thermostat

- **Touchscreen user interface**

- The sleek design, menu-driven programming and large touchscreen display are all here

CommercialPRO® 7000

- **Saves energy**

- Effortless programming helps your customers save up to 33% off their energy bill¹

- **Meets commercial building codes**

- Pre-occupancy Purge, Economizer Output and Override Limits meet all fresh air and override limitation requirements
- Qualifies for utility rebates²
- Title 24/IECC/ASHRAE codes

- **Multiple lockout levels**

- Save energy and money by preventing unauthorized setting changes

- **Compatible with auxiliary commercial devices**

- Commercial sensors
- Economizers

- **Commercial comfort**

- Commercial Algorithm, configurable recovery ramps and temporary override button allow users to control at setpoint and guarantee a comfortable environment

¹ If used as directed. Savings may vary depending on geographic region and usage.

² Where applicable.

Mnemonic Number	HONEYWELL OS Number	Description	Application
THT02519	TB8220U1003	Commercial VisionPRO® 8000 Programmable Thermostat	– 2 Heat/2 Cool Conventional – 3 Heat/2 Cool Heat Pump
THT02572	TB7220U1012	CommercialPRO® 7000 Programmable Thermostat	

Replacements					Sensor Compatibility
	Honeywell	White-Rodgers	Invensys/ Robertshaw	Carrier/Totaline	
Commercial VisionPRO® 8000	TB8220U1003	T7300 with Q7300A2016, Q7300A2008, Q7300C2004 and Q7300C2012 Subbase	IF90 Series, IF80 Series	P374-2100, P374-2200, P374-2300, 33S250-01, 33CS220-01, 33CS071-01, 33CSP2-WC, 33CSSN2-WC	TR21, TR21-A (averaging), C7772A1012 (flush mount), C7770A1006 (return air duct), C7041P2004 (button sensor)
CommercialPRO® 7000	TB7220U1012	T7300 with Q7300A2016, Q7300A2008, Q7300C2004 and Q7300C2012			

Multispeed and Multipurpose Thermostats

COMMERCIAL



MultiPRO™ 7000

Multispeed and Multipurpose Thermostat

- **Large, easy-to-read display**
 - Screen size is more than double competitive thermostats in this class, allowing for more information to be displayed on the easy-to-view backlit display.
- **Programmable or non-programmable modes**
- **Saves energy**
 - Effortless programming helps your customers save up to 33% off their energy bill¹
 - Remote setback input for occupancy sensors or timeclocks
 - VersaSpeed™ fan ramping algorithm and auto fan reset algorithm (fan coil and PTAC applications)
- **Multiple lockout levels**
 - Save energy and money by preventing unauthorized setting changes
- **Compatible with commercial sensors**
- **Commercial comfort**
 - Commercial Algorithm, configurable recovery ramps and temporary override button allow users to control at setpoint and guarantee a comfortable environment
- **Multispeed and Multipurpose**
 - 1 Heat/1 Cool Conventional (single speed)
 - 2 Heat/1 Cool Heat Pump (single speed)
 - 2 Heat/1 Cool PTAC (2 speeds)
 - 2 or 4-pipe Fan Coil (3 speeds)

¹ If used as directed. Savings may vary depending on geographic region and usage.

Mnemonic Number	HONEYWELL OS Number	Description	Application
THT02768	TB7100A1000	MultiPRO™ Multispeed and Multipurpose Thermostat	1 Heat/1 Cool Conventional, 2 Heat/1 Cool Heat Pump, 2 Heat/1 Cool PTAC Systems and 2 or 4-pipe Fan Coil

Replacements						Sensor Compatibility	
	Honeywell	White-Rodgers	Invensys/Robertshaw	Carrier/Toteline	PSG Controls		
MultiPRO™	TB7100A1000	T8574B2016, T8575B2007, T8575C2005, T8575D2003	IF90-371, IF96-344, IF97-371, IF80-224, IF80-241, IF80-261, IF86-244, IF87-251, IF82-261, IF89-211	97012, 9610, 9700i, 300-224, 300-225, 300-226,	P274-0100, P274-1100, P374-0200, P374-0300	DFC-20YU6585F, DPFC-024U2F, DPFC-024K2F, TDMS24-AH22CB	TR21, TR21-A C7772A1012 (flush mount), C7770A1006 (return air duct), C7041P2004 (button sensor) WSK-24



After-Hours Control in Office Buildings

- The Override button can be configured for a length of time (1, 2, 3, 4 hours) and can be configured for an exact override setpoint through the use of the lockout level set-up and the temperature range stop setup. A user may override to an exact setpoint or be given a setpoint range to choose from.
- Provides comfort during after-hours occupancy while maintaining energy savings after the tenant leaves the building.



Schools – Individual Zone Control

- Cancel Period button allows thermostat to remain in permanent unoccupied mode to provide energy savings for school classrooms not being used.
- Teachers wanting to use a classroom press the Override button and the thermostat enters the occupied period providing the necessary comfort.
- The Override button can be configured for a length of time (1, 2, 3, 4 hours) and can be configured for an exact override setpoint through the use of the lockout level setup and the temperature range stop setup. A user may override to an exact setpoint or be given a setpoint range to choose from.
- During long holidays or during summer vacation, the thermostat can be programmed with the Holiday button to provide the greatest amount of energy savings.



Restaurant/Food Service Control

- Honeywell's Commercial Algorithm provides the best comfort control to react to the challenging environments of food service and restaurant environments. The commercial algorithm is tuned to provide the tightest comfort control and react quickly to changing load demands via fast-sensing time constants.
- Economizer function allows restaurants to meet the appropriate ventilation requirements and is also important to balance the air intake of the restaurant. Restaurants that are not properly balanced do not achieve good comfort control as they draw in unconditioned air.
- Remote sensing configuration options allow the use of commercial 10K ohm and 20K ohm sensors to provide any remote sensing combination (1 to 9+ sensors) to create an averaging network.

Condominiums/Hotels

- Honeywell's MultiPRO™ thermostat uses the patent pending VersaSpeed™ fan ramping algorithm to give multiunit facilities such as hotels, condos, dorms and retirement facilities more control and additional savings through the elimination of unnecessary energy use.
- The fan coil and PTAC applications on the MultiPRO™ make it a perfect thermostat for hotels or condominiums. (See our SuitePRO™ thermostat, too)

Economizer Integration

- Compatible with Honeywell Economizer controllers, which generate free cooling if appropriate outside air and/or humidity conditions exist. (Not available on MultiPRO™)
- Thermostats are integrated with economizers to maintain minimum ventilation requirements of the building during occupied periods. During unoccupied periods, thermostats can override the economizer to fully close the damper, thereby eliminating air infiltration into the building to maximize energy savings.

Mnemonic Number	HONEYWELL OS Number	Benefit
THT02519	TB8220U1003	Energy Savings, Comfort, Fresh Air
THT02572	TB7220U1012	Energy Savings, Comfort, Fresh Air
THT02768	TB7100A1000	Energy Savings, Comfort and Versatility

Remote Sensing

Can be configured using Honeywell's line of 10K ohm and 20K ohm commercial sensors, supporting the following applications that residential thermostats don't:

- Temperature Averaging Networks

Because commercial thermostats can be configured to a 20K ohm network, temperature average networks of anywhere from 1 to 9+ sensors can be deployed. Combinations of 10K ohm and 20K ohm sensors are used to create the averaging network. The most popular sensors are the TR21 and TR21-A (averaging) 10K sensor and the TR21 and TR21-A 20K sensor.

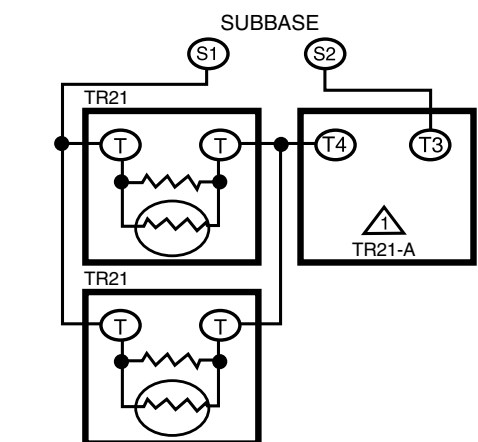

 THE TR21-A IS A 10K OHM SENSOR

- Room Temperature Control

Performed via a sensing network using the following sensors:

- Wall Sensors: TR21-A (10K) for averaging only, TR21 (20K), C7189U1005 (10K)
- Flush Mount Sensors: C7772A1012 (20K)
- Button Sensors: C7041P (20K)

- Duct Return Temperature Control

Performed using the following 20K sensors: C7041B/C7041C/C7770A/C7041J

Unit Vent

- Can be programmed to control ASHRAE Cycle 1 unit vent applications.
- Unit vent outside-air damper can be programmed through the Economizer feature. When the unit vent is on and occupied, the thermostat will enable the economizer relay to keep the outside air damper at the maximum percentage opening. Only maximum percentage opening is available; the thermostat will not modulate the damper. When the unit vent is unoccupied, the thermostat will close the damper.
- Range Stop feature can be configured to program a low limit setpoint to prevent equipment damage from freezing.

Commercial Codes

- Comply with commercial building codes and meet the most rigorous standard, California's Title 24.
- No hold button is available, so the thermostat remains in permanent schedule.
- Override button allows the tenant to override an unoccupied mode for up to 4 hours and can be configured for an exact override setpoint. Depending on the partial lockout level deployed, a user may override to an exact setpoint or be given a setpoint range to choose from.
- Pre-Occupancy Purge and Economizer functions allow the building owner to meet all HVAC ventilation codes for commercial buildings.

Lighting Load Reduction (TOD)

- Commercial buildings are frequently automated to turn off lighting loads. Lighting loads can use even more energy than HVAC systems in commercial buildings, and 79% of commercial buildings have off-hours lighting load reduction control. By using the time-of-day relay (TOD) in conjunction with a lighting control system, users can automate their lighting loads. (Not available on MultiPRO™)



Infrared Thermostat Interface Module (IR/TIM)

- Eliminates hard-to-find cables that connect a Palm® to the thermostat interface module.
- T7350 thermostat programming can be done on the Palm and communicated via infrared to the I/R TIM, which automatically transmits it to the T7350. Simply download the T7350 program software at customer.honeywell.com onto the Palm. Once the T7350 is configured on the Palm, it can be beamed via the infrared port to the I/R TIM.
- Most newer Palms are compatible.
- Programs can be saved on the Palm and beamed again and again to other T7350s, saving time.
- Users can capitalize on more T7350 features that are only accessible by using a Palm, including:
 - 365-day holiday programming
 - Configurable ramp rates
 - Configurable PID loop tuning
 - Configurable standby setpoints
 - Configurable outdoor air temp lockout
 - Configurable high and low discharge air limits
 - Configurable dehumidification parameters

Mnemonic Number	HONEYWELL OS Number
KIT15298	50014064-001



Thermostat Guards

Mnemonic Number	HONEYWELL OS Number	Description
COV02638	TG510A1001	Small universal thermostat guard with clear cover and base, and opaque wallplate
COV02640	TG510D1005	Small universal thermostat guard with beige painted steel cover, opaque ring base and wallplate
COV02643	TG511D1004	Medium universal thermostat guard with beige painted steel cover, opaque ring base and wallplate
GRD01185	TG512A1009	Large universal thermostat guard with clear cover and base, and opaque wallplate
COV02646	TG512D1003	Large universal thermostat guard with beige painted steel cover, and opaque ring base and wallplate



Remote Room Temperature and Discharge Air Sensors

- Full line of remote wall sensors.
- Gives user the option to have setpoint knobs/buttons, override button or sensor only.
- Flush mount versions are available for high traffic areas where protruding objects would get broken.

Compatible Sensors

Honeywell has a full line of sensors that are compatible with our commercial thermostats.



WSK-24
Wireless Occupancy
Sensor



TR23-WK
Wireless Temperature
Sensor Kit



C7772A1012
Remote Flush
Mount Wall
Sensor



C7031G2014
3K Platinum
Outdoor Air
Sensor



TR23-WS
Wireless
Temperature
Sensor

Remote Room Sensors		
Mnemonic Number	HONEYWELL OS Number	
SEN01642	TR21	20K
SEN01643	TR21-A	10K Averaging
SEN01644	TR22	20K, ±5° Setpoint Adj.
SEN01745	TR23	20K, ±5° Setpoint Adj. & Bypass
SEN01645	TR24	20K, Bypass
SEN01316	C7189U1005	Remote Indoor
SEN01744	C7772A1012	20K Flush Mount Sensor

Remote Humidity Sensors		
TRM00054	H7625A1008	2% Accuracy Wall Mount
TRM00055	H7625B1006	2% Accuracy Duct Mount
TRM00056	H7635C1002	3% Accuracy Outdoor

Discharge Air Sensors		
SEN01646	C7041B2005	20K Discharge Air, 5" Duct Insertion
SEN01647	C7041B2013	20K Discharge Air, 12" Duct Insertion

Outdoor Air Sensors		
SEN01270	C7031G2014	3K Platinum Outdoor Air Sensor
SEN01317	C7089U1006	C7089 Remote Outdoor Sensor

Remote Pipe Sensor		
SEN01638	PS20	20K Analog Pipe

Wireless Sensor		
SEN01747	TR23-WS	Wireless temp/setpoint/override sensor only
KIT15511	TR23-WK	TR23 type sensor (temp, setpoint knob, override button) with receiver
SEN01746	TR21-WS	Wireless temp sensor only
KIT15510	TR21-WK	TR21 type sensor (temp only) with receiver
REC00853	WRECVR	Receiver only

Wireless Occupancy Sensor		
KIT15498	WSK-24	Includes 24V receiver, wireless PIR sensor and wireless door sensor
SEN01739	50037735-001	Optional 2nd wireless door sensor



Economizer

Economizers Compatible with Commercial Thermostats

Honeywell has a range of economizer controls that are compatible with the T7350, T7351, TB8220 and TB7220. These economizers save energy by bringing in cool outdoor air when there is a need for cooling and some models also adjust outdoor damper position based on indoor air quality (CO₂) for demand control ventilation.

- W7459, W7210 (economizer only)
- W7212, W7213, W7214 (economizer and Demand Control Ventilation)

The Demand Control Ventilation economizers listed above have the latest features, including indoor air quality maximum output, night setback terminal and they drive a 2- to 10-volt motor.

Commercial Modulating Zoning Thermostats



ZonePRO®

Commercial Modulating Zoning Thermostat

- **Good looks**
 - Many thermostats used for this application look very outdated
- **Price**
 - Very cost-effective alternative to an expensive networked zoning system
- **Flexibility**
 - Has more features and fits more applications than other thermostats in this market (setback input, additional analog and triac output on the B models)
 - Duct sensor and remote sensor capabilities are standard, allowing flexibility to do room temperature sensing, discharge air control, sensor averaging
- **Easy to install**
 - Easy to wire
 - Easy to program the configuration code
 - Power output graph helps the installer understand if the actuator is operating properly
- **Saves energy**
 - Override button and night setback
 - Range stop temperature limits
 - System control modes such as fresh air control and limited cooling modes

Mnemonic Number	HONEYWELL OS Number	Schedule Options		User Interface	Output Type	Universal Applications	Power Method	Features and Functions						Compatible Actuators	Compatible Valves	Sensors and Accessories	Replaces
		Program Options	Temporary Override					Permanent Memory Retention	Night Setback	Range Stops	Power Output Graph	Remote Sensing	On-Demand Backlighting				
THT02719	TB6980A1007	Non-Programmable with Night Setback Input	Yes	Digital	Floating, Single Output	Auto Changeover, Discharge Air Temperature, Return Air Temperature, Room Temperature, Limited Cooling	24 VAC	Yes	Yes	Yes	Yes	Yes (indoor, outdoor, supply)	Yes	ML6984A1006, ML6420, ML6161B2024, MN6105A1011	VC6930, VC6934, VC6936, M6410, M6435	R841 Series of electromechanical relays, 50014157-001 air duct sensor, 50014156-002 space sensor, ST6008A1003 and ST7009A1003 time clocks, 209651A wall plate, D640 and D690 dampers	T6984A1059
THT02571	TB6980B1006				Floating, Multi Output (extra analog and digital output)												T6984D1046, T6984E1043
THT02573	TB7980A1006				Analog (0-10 V or 2-10 V), Single Output												T7984A1057, T7984A1065
THT02574	TB7980B1005				Analog (0-10 V or 2-10 V), Multi Output (extra analog and digital output)												T7984B1055, T7984C1053

ZonePRO® Applications

Stand Alone VAV Pressure Dependent (VVT Zoning) Control

- Typical building applications include zoning for office buildings, airports, strip-malls and multi-tenant facilities that have multiple terminal zones that run off of a single air-handler.
- Thermostats provide modulating control (floating or analog) for each zone.
- Can be configured for cool only, heat only or auto changeover. Up to 2 re-heat outputs are available if the discharge air from the air handler needs to be heated at the zone. (B models)
- Remote sensors are compatible with all ZonePRO® models if remote room sensing or return air temperature sensing is desired.
- May also be used at the air handler to control the temperature of the fresh air supply or provide limited cooling using outdoor air when appropriate.
- All ZonePRO thermostats come with energy-saving range stop and night setback configurability.

Hydronic Control & Modulating Heating

- Can be used for modulating hydronic heating or cooling applications.
- Other common applications include radiant panel heaters, cabinet heaters, fin-tube radiators and other electric or hydronic re-heat applications.

TB7980B1005: Cooling Only Pressure Dependent VAV Zone Reheat and Electric Baseboard Heat

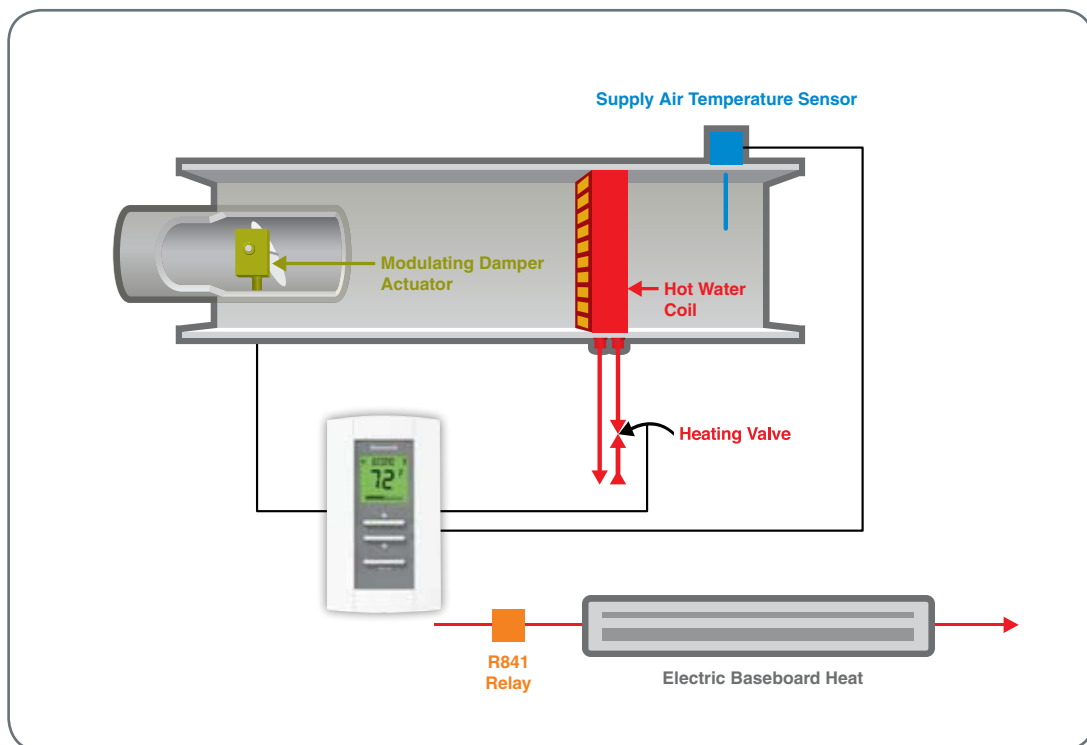

Other Thermostats



SuitePRO™ Digital Fan Coil

- **Simple Design** — Only four buttons are needed to operate the SuitePRO, making it easy to configure as well as easy for guests to operate, thus reducing nuisance callbacks.
- **Easy Installation** — Lead wires are attached for faster installation for line voltage models, reducing wiring time (TB6575A/B models only).
- **Easy Configuration** — The large display and intuitive interface make setup a snap.
- **Built-In Algorithms** — The setup algorithms are all pre-programmed, so you simply need to configure the durations during setup.
- **Freeze Protection** — If the temperature drops below 40° F, SuitePRO will turn on the heat. Equipment and furnishings will be protected, and if there's an emergency, you'll have more time to respond.
- **WSK-24 sensor compatibility** (Wireless Occupancy Sensor)

Mnemonic Number	HONEYWELL OS Number	Application
THT02765	TB6575A1000	2/4 pipe 120/240V fan coil thermostat with manual or auto changeover
THT02766	TB6575B1000	2 pipe only 120/240V fan coil thermostat with manual or seasonal changeover
THT02767	TB8575A1000	2/4 pipe 24V fan coil thermostat with manual or auto changeover



Electromechanical Fan Coil

- **Popular for the replacement market**
 - Large installed base, popular proven mechanical design

Mnemonic Number	HONEYWELL OS Number	Application
THT01698	T4039B1008	120 – 277V cooling only fan coil thermostat with On-Off system switch and Hi-Med-Lo-Off fan switch
THT01704	T4039J1026	120 – 277V 4 pipe fan coil, automatic heat-cool changeover with Off-Hi-Lo fan switch, tan color
THT01708	T4039M1103	120 – 277V 4 pipe fan coil, automatic heat-cool changeover with On-Off system switch and Hi-Med-Lo fan switch, white color
THT01709	T4039S1016	120 – 277V 4 pipe fan coil, manual heat-cool changeover with Heat-Off-Cool system switch and Hi-Med-Lo fan switch, tan color
THT02594	T6169B4017	120 – 277V 2 pipe fan coil manual changeover with Heat-Off-Cool system switch, no fan switching, beige color



Line Volt

- **Simple interface for control of line voltage heaters**
 - Easy for occupants to read and change setpoints

Mnemonic Number	HONEYWELL OS Number	Application
THT02303	T651A3018	Degree F scale, for heavy-duty line voltage heating systems

Pneumatic Thermostats



- Pneumatic are the true open system
 - Honeywell Pneumatics thermostats will work with all competitive systems
- Provide design that has with stood the test of time
- Fahrenheit and Celsius options available
- One or two pipe applications are available
- Direct and Reverse Acting thermostats
- High and Low capacity thermostats
- Convertastat kits conveniently replace most other competitors products
- Day/Night and Heating/Cooling thermostats allow for energy savings with existing Pneumatic systems and without the need of expensive upgrades.
- All thermostats are factory calibrated
- Operating temperature 100F maximum
- Storage temperature 150F maximum
- 0 – 25 PSI ranges
 - 25 PSI maximum operating pressure

Mnemonic Number	HONEYWELL OS Number	Description	Action	Pipes	Setpoint	Setpoint	Includes
THT02800	TP9600A1007/U	Thermostat	Direct	2	1	60F-90F	Plastic Cover
THT02801	TP9600B1006/U	Thermostat	Reverse	2	1	60F-90F	Plastic Cover
THT00404	TP970A2004/U	Thermostat	Direct	2	1	60F-90F	Cover Sold Separately
THT01993	TP970A2145/U	Convertastat	Direct	2	1	60F-90F	Chrome Cover, Universal Wall Plate
THT00403	TP970B2002/U	Thermostat	Reverse	2	1	60F-90F	Cover Sold Separately
THT02007	TP970B2077/U	Convertastat	Reverse	2	1	60F-90F	Chrome Cover, Universal Wall Plate
THT01988	TP970A2038/U		Direct			60F-90F	
THT01999	TP970A2259/U		Direct			60F-90F	
THT02003	TP970B2010/U		Reverse			15C-30C	
THT02017	TP971A2003/U	Day/Night	Direct	2	2	Day: 60F-90F, Night:50F-80F	Cover Sold Separately
THT02028	TP971B2001/U	Day/Night	Reverse	2	2	Day: 60F-90F, Night:50F-80F	Cover Sold Separately
THT02033	TP971C2009/U	Day/Night	Direct	3	2	Day: 60F-90F, Night:50F-80F	Cover Sold Separately
THT02036	TP972A2002/U	Heating/Cooling	Direct	2	2	60F-90F	Cover Sold Separately
THT02003	TP972A2010/U	Heating/Cooling	Direct	2	2	15C-30C	Cover Sold Separately
THT02043	TP972A2192/U	Convertastat	Direct	2	2	60F-90F	Chrome Cober, Universal Wall Plate
THT00342	TP973B2066/U	Low Capacity Thermostat	Reverse	1	1	60F-90F	Cover Sold Separately
KIT06086	14004406-910/U	Thermostat Cover	-	-	-	60F-90F	Satin Chrome Cover with display

Electronic Remote Standalone Controllers



T775

Provide on/off, modulating, or reset control in applications where electronic accuracy in addition to remote sensing is desired.

Standard Models

- Available with one, two or four SPDT relay output stages and/or modulating outputs (0-10 Vdc, 2-10 Vdc, 4-20 mA and electronic Series 90 selectable). All models have built-in time-clock scheduler for setback.
- Typical applications include
 - On/off control of fans, motors and heaters
 - Proportional or floating control of damper and valve actuators
 - Outdoor reset of heating and cooling systems

Mnemonic Number	HONEYWELL OS Number	Description	Replaces	Relay Outputs	Analog Outputs Selectable: 4-20 mA, 0-10 Vdc, 2-10 Vdc and Series 90	Floating Output ¹	Sensor Inputs Available	# Sensors Included ²
CNT05930	T775A2009	Standard	T775A1001	1 SPDT			1	1
CNT05086	T775B2016	Standard-NEMA 4X		2 SPDT		1	2	1
CNT05076	T775B2032	Standard	T775A1019, T775B1000	2 SPDT		1	2	1
CNT05087	T775B2024	Standard-NEMA 4X	T775C1009, T775D1008	4 SPDT		2	2	1
CNT05077	T775B2040	Standard	T775A1027, T775A1035, T775B1018, T775B1026	4 SPDT		2	2	1
CNT05078	T775M2006	Modulating		None	2		2	1
CNT05088	T775M2022	Modulating-NEMA 4X		2 SPDT	2		2	1
CNT05079	T775M2048	Modulating	T775E1015, T775E1023, T775E1056, T775E1064, T775E1098	2 SPDT	2		2	1
CNT05089	T775M2014	Modulating-NEMA 4X	T775G1005, T775G1013, T775G1021, T775G1039	4 SPDT	2		2	1
CNT05080	T775M2030	Modulating	T775E1114, T775F1022, T775F1055, T775F1089	4 SPDT	2		2	1
CNT05081	T775R2035	With Reset option	T775J1001, T775J1076	2 SPDT		1	2	2
CNT05082	T775R2043	With Reset option	T775J1019, T775J1027, T775J1035	None	2		2	2
CNT05083	T775R2027	With Reset option	T775J1043, T775J1050, T775J1068	2 SPDT	2		2	2
CNT05084	T775R2001	With Reset option		4 SPDT		2	2	2
CNT05085	T775R2019	With Reset option		4 SPDT	2		2	2

¹ One floating output eliminates two relay outputs.

² Sensors are 1097 ohms PTC. The standard sensor (50021579-001) ships with all but NEMA 4x models. The water resistant sensor with 5 ft. leads ships with all NEMA 4x models. See the Specification Data for a complete list of compatible components.

T775 Special Models

T775U — Universal model controls pressure, humidity, temperature or any control medium that inputs 1097 ohms PTC, 0-10 Vdc or 4-20 mA. CO₂ sensors are compatible but reading displayed in percent, not ppm.

T775P — Special boiler model with features like WWSD, Alarm and control of up to 12 stages from a single setpoint using optional 4-relay expansion modules T775S.

T775L — Special sequencing module allows configuration of up to 12 relay outputs with one or two setpoints in any number and combination desired. Do 3 heat/7 cool, 6 heat/2 cool, 4 heat/2 heat — whatever you desire.





Mnemonic Number	HONEYWELL OS Number	Description	Replaces	Relay Outputs	Analog Outputs 4-20 mA, 0-10 Vdc, 2-10 Vdc and Series 90	Digital Output	Dedicated Pump Output	Sensor Inputs Available	# Sensors Included	Expandable ¹	Output Reset
CNT05090	T775P2003	Special Boiler with Reset		4 SPDT		1	•	3	3	•	•
CNT05091	T775L2007	Stage Sequencer with Reset Option		4 SPDT ²				2	1	•	•
CNT05092	T775U2006	Universal — Humidity, Pressure, etc.	H775A1006, H775A1022, H775A1048, H775A1063, H775B1005, H775C1004, H775D1003, H775E1002	2 SPDT	2			2 ³			•
MOD01656	T775S2008	Relay Expansion Module		4 SPDT	Use with T775P or T775L						

¹ 4 or 8 more relays possible by adding one or two T775S2008 4-Relay Expansion Module(s).





² Up to 2 independent non-sequenced relays are also available.

³ First input configurable for temperature, 0-10 Vdc, or 4-20 mA; second input temperature only for reset.

Prestige™ Comfort Systems Selection Guide

		SOLUTIONS				SCHEDULE OPTIONS			APPLICATION					POWER METHOD		
Kit Includes:		Displays Outdoor Temperature and Humidity	Controls Humidification and Dehumidification	Temperature Control on Demand	Adjust All RedLINK™-Enabled Thermostats from a Single Control	Program Options	ENERGY STAR®	Fixed and Adjustable Temporary Override	Permanent and Vacation Holds	Stages	Gas, Oil or Electric	Heat Pump	Forced Warm Air	Hot Water	Steam/Gravity	
PRESTIGE™ COMFORT SYSTEMS																
	Prestige HD, Portable Comfort Control and Wireless Outdoor Sensor YTHX9321R5003	•	•	•	•	7-Day	•	•	•	Up to 3H/2C Heat Pump or 2H/2C Conventional	•	•	•	•	•	Prestige — Hardwired Portable Comfort Control and Wireless Outdoor Sensor — Battery
	Prestige HD and Wireless Outdoor Sensor YTHX9321R5012	•	•	•*	•*	7-Day	•	•	•	Up to 3H/2C Heat Pump or 2H/2C Conventional	•	•	•	•	•	Prestige — Hardwired Wireless Outdoor Sensor — Battery
	Prestige SD, Portable Comfort Control and Wireless Outdoor Sensor YTHX9321R1000	•	•	•	•	7-Day	•	•	•	Up to 3H/2C Heat Pump or 2H/2C Conventional	•	•	•	•	•	Prestige — Hardwired Portable Comfort Control and Wireless Outdoor Sensor — Battery
	Prestige SD and Wireless Outdoor Sensor YTHX9321R1011	•	•	•*	•*	7-Day	•	•	•	Up to 3H/2C Heat Pump or 2H/2C Conventional	•	•	•	•	•	Prestige — Hardwired Wireless Outdoor Sensor — Battery

Wireless FocusPRO® Systems Selection Guide

		SOLUTIONS					SCHEDULE OPTIONS			USER INTERFACE		APPLICATION		
Kit Includes:		Relocate Thermostat Without Running New Wires	Upgrade to Multi-stage or Add Cooling Without Running New Thermostat Wires	Displays Outdoor Temperature and Humidity	Temperature Control on Demand	Adjust All RedLINK™-Enabled Thermostats from a Single Control	Program Options	ENERGY STAR®	Temporary Override	Permanent Hold	Stages	Gas, Oil or Electric	Heat Pump	
WIRELESS FOCUSPRO® SYSTEMS (NON-ZONED)														
	Programmable FocusPRO, Equipment Interface Module, Portable Comfort Control, Wireless Outdoor Sensor and Return Air Sensor YTH6320R1015	•	•	•	•	•	5-1-1 / 5-2 Day	•	•	•	FocusPRO — Soft Keys Portable Comfort Control — Touchscreen	Up to 3H/2C Heat Pump or 2H/2C Conventional	•	•
	Programmable FocusPRO, Equipment Interface Module and Return Air Sensor YTH6320R1001	•	•	•*	•**	•**	5-1-1 / 5-2 Day	•	•	•	Soft Keys	Up to 3H/2C Heat Pump or 2H/2C Conventional	•	•
	Non-Programmable FocusPRO, Equipment Interface Module, Portable Comfort Control, Wireless Outdoor Sensor and Return Air Sensor YTH5320R1017	•	•	•	•	•					FocusPRO — Soft Keys Portable Comfort Control — Touchscreen	Up to 3H/2C Heat Pump or 2H/2C Conventional	•	•
	Non-Programmable FocusPRO, Equipment Interface Module and Return Air Sensor YTH5320R1000	•	•	•*	•**	•**					Soft Keys	Up to 3H/2C Heat Pump or 2H/2C Conventional	•	•

FEATURES & FUNCTIONS														DISPLAY INFORMATION					LIMITED WARRANTY	WIRING TERMINALS		
Touchscreen User Interface	On-Screen Help	Real-Time Clock	Permanent Memory Retention	Auto or Manual Changeover	Interview-Based Programming	USB Port for Uploading Logo and Preset Installer Setup	Adaptive Intelligent Recovery™/Early Start™	Temperature Setpoint Limits	Keypad Lockout	Programmable Fan	Advanced Dual-Fuel Heat Pump Operation	Language Options	Remote Locator	Display Size (Viewable sq. in.)	High-Definition (HD) Color Display	Standard-Definition (SD) Display	Backlighting — Continuous or On-Demand	Simultaneous Display of Room and Set Temperatures	Filter, Humidifier Pad and UV Lamp Replacement Reminder	Dealer Logo On-Screen		
•	•	•	•	•	•	•	•	•	•	•	•	•	Prestige — 8 Portable Comfort Control — 7	•	•	•	•	•	•	Prestige — 5 years	Portable Comfort Control and Wireless Outdoor Sensor — 1 year	C, R, Rc, W-O/B, W2-Aux/E, Y, Y2, G, L, K, HUM, HUM, DHM, DHM
•	•	•	•	•	•	•	•	•	•	•	•	•	8	•	•	•	•	•	•	Prestige — 5 years	Wireless Outdoor Sensor — 1 year	C, R, Rc, W-O/B, W2-Aux/E, Y, Y2, G, L, K, HUM, HUM, DHM, DHM
•	•	•	•	•	•	•	•	•	•	•	•	•	Prestige — 8 Portable Comfort Control — 7	•	•	•	•	•	•	Prestige — 5 years	Portable Comfort Control and Wireless Outdoor Sensor — 1 year	C, R, Rc, W-O/B, W2-Aux/E, Y, Y2, G, L, K, HUM, HUM, DHM, DHM
•	•	•	•	•	•	•	•	•	•	•	•	•	8	•	•	•	•	•	•	Prestige — 5 years	Wireless Outdoor Sensor — 1 year	C, R, Rc, W-O/B, W2-Aux/E, Y, Y2, G, L, K, HUM, HUM, DHM, DHM

* REM5000R1001 required

POWER METHOD			FEATURES AND FUNCTIONS									DISPLAY INFORMATION			LIMITED WARRANTY	WIRING TERMINALS
Forced Warm Air	Hot Water	Steam/Gravity	Permanent Memory Retention	Selectable Auto or Manual Changeover	Adaptive Intelligent Recovery™/Early Start™	Temperature Setpoint Limits	Remote Locator	Backup Control	Private Labeling Available	Display Size (Viewable sq. in.)	On-Demand Backlighting	Simultaneous Display of Room and Set Temperatures				
•	•	•	Equipment Interface Module — Hardwired	•	•	•	•	•	•	FocusPRO — 5.09 Portable Comfort Control — 7	•	•	FocusPRO and Equipment Interface Module — 5 years	Equipment Interface Module C, R, Rc, Rh, W-O/B, W2-Aux/E, Y, Y2, G, L, RAS, RAS		
•	•	•	Equipment Interface Module — Hardwired FocusPRO — Battery	•	•	•	•	•	•	5.09	•	•	FocusPRO and Equipment Interface Module — 5 years	Equipment Interface Module C, R, Rc, Rh, W-O/B, W2-Aux/E, Y, Y2, G, L, RAS, RAS		
•	•	•	Equipment Interface Module — Hardwired FocusPRO, Portable Comfort Control and Wireless Outdoor Sensor — Battery	•	•	•	•	•	•	FocusPRO — 5.09 Portable Comfort Control — 7	•	•	FocusPRO and Equipment Interface Module — 5 years	Equipment Interface Module C, R, Rc, Rh, W-O/B, W2-Aux/E, Y, Y2, G, L, RAS, RAS		
•	•	•	Equipment Interface Module — Hardwired FocusPRO — Battery	•	•	•	•	•	•	5.09	•	•	FocusPRO and Equipment Interface Module — 5 years	Equipment Interface Module C, R, Rc, Rh, W-O/B, W2-Aux/E, Y, Y2, G, L, RAS, RAS		

* C7089R1013 required

** REM5000R1001 required

RESIDENTIAL

Wireless Comfort Systems

Prestige™ Comfort System

Exclusive Honeywell RedLINK Technology Makes It Possible



- World's first high-definition, full-color thermostat.
- Patented, interview-based programming and installer set-up.
- USB port for transferring installer setup options and adding dealer logo on-screen.
- Wires to the equipment like a traditional thermostat, but is RedLINK-enabled to work with other RedLINK-enabled devices.
- Displays outdoor temperature and humidity.
- Wireless humidity control with TrueSTEAM™ humidifiers.
- Up to 3H/2C heat pump or up to 2H/2C conventional.
- Enabled for Dual Fuel control when used with a Wireless Outdoor Sensor.

Mnemonic Number	Honeywell OS Number	Description
KIT15288	YTHX9321R5003	Prestige HD Thermostat, Portable Comfort Control and Wireless Outdoor Sensor
KIT15289	YTHX9321R5012	Prestige HD Thermostat and Wireless Outdoor Sensor

NOTE: The Redlink wireless portfolio was developed for residential applications. However, many are being installed in commercial buildings. When using the Redlink thermostats in a commercial application, we recommend using the wireless signal strength test during installation. System Test # 02 is the wireless signal strength test; it can be found in the product data sheet included with the product.

Steps:

1. Power the Equipment Interface Module at the location where it will be installed.
2. Enter installer test in the thermostat by pressing both up and down buttons at the same time for about 3 seconds until the screen changes.
3. The first test that appears is the wireless signal strength test (02).
4. Hold the thermostat in the desired mounting location. Press the up arrow to begin the wireless signal strength test. Wait will be displayed momentarily as it searches for a signal.
5. The thermostat will then indicate "Signal OK" or "No Signal". When the Signal is OK, it will display a value between 5 to 10. Honeywell recommends a reading of 5 or higher (5 is the minimum, 10 – best). A reading of 5 or higher means the thermostat will provide reliable wireless operation in that mounting location.
6. If it displays "No Signal", it will display --. This means the thermostat did not receive a signal back from the Equipment Interface Module or Zone Panel during the test and it is recommended to find an alternate mounting location for the thermostat. Move the thermostat to a different location and repeat the test.

Wireless FocusPRO® Comfort Systems











RESIDENTIAL

- **Wireless communication to equipment with an Equipment Interface Module.**
- **Relocate a thermostat or upgrade equipment without running new wires.**
- **RedLINK™-enabled to work with the Portable Comfort Control and Wireless Outdoor Sensor.**
- **Enabled for Dual Fuel control when used with a Wireless Outdoor Sensor.**
- **Displays outdoor temperature and humidity.**
- **Up to 3H/2C heat pump or up to 2H/2C conventional.**
- **Return Air Sensor for backup protection.**
- **5 -Year Warranty**

Mnemonic Number	Honeywell OS Number	Description
KIT15292	YTH6320R1015	Wireless FocusPRO® 5-1-1 Programmable Thermostat, Equipment Interface Module, Return Air Sensor, Portable Comfort Control and Wireless Outdoor Sensor
KIT15293	YTH6320R1001	Wireless FocusPRO® 5-1-1 Programmable Thermostat, Equipment Interface Module and Return Air Sensor.
KIT15296	YTH6320R1023	Wireless FocusPRO® 5-1-1 Programmable Thermostat and Wireless Zoning Adaptor
KIT15294	YTH5320R1017	Wireless FocusPRO® Non-Programmable Thermostat, Equipment Interface Module, Return Air Sensor, Portable Comfort Control and Wireless Outdoor Sensor
KIT15295	YTH5320R1000	Wireless FocusPRO® Non-Programmable Thermostat, Equipment Interface Module and Return Air Sensor.
KIT15297	YTH5320R1025	Wireless FocusPRO® Non-Programmable Thermostat and Wireless Zoning Adaptor
CNT05214	REM5000R1001	Portable Comfort Control
SEN01627	C7089R1013	Wireless Outdoor Sensor

Programmable & Non-Programmable Thermostats

	MODEL	SCHEDULE OPTIONS				USER INTERFACE	APPLICATION				POWER METHOD	On Screen Help	Interview-Based Programming	USB Port for Uploading Logo and Preset Installer Setup	Real-Time Clock (Automatically Updates Daylight Savings)	Permanent Memory Retention	Selectable Auto or Manual Changeover	Adaptive Intelligent Recovery™	Temperature Setpoint Limits	Keypad Lockout
		Program Options	ENERGY STAR®	Temporary Override	Permanent Hold		Vacation Hold	Stages	Gas, Oil or Electric	Heat Pump										
 Prestige™ HD	THX9321R5000	7-Day	•	Fixed and Adjustable	•	•	Touchscreen	Up to 3 Heat/2 Cool	•	•				•	•	•	•	•	•	•
 VisionPRO® IAQ Total Home Comfort System	YTH9421C1010 (includes thermostat, Equipment Interface Module, and Outdoor Temperature Sensor)	7-Day	•	Fixed and Adjustable	•	•	Touchscreen	Up to 4 Heat/2 Cool	•	•				•	•	•	•	•	•	•
 VisionPRO® 8000 Touchscreen Programmable	TH8110U1003	7-Day	•	Fixed and Adjustable	•	•	Touchscreen	1 Heat/1 Cool	•	•	•					•	•	•	•	•
	TH8320U1008	7-Day	•	Fixed and Adjustable	•	•	Touchscreen	Up to 3 Heat/2 Cool	•	•	•					•	•	•	•	•
	TH8321U1006 with dehumidification	7-Day	•	Fixed and Adjustable	•	•	Touchscreen	Up to 3 Heat/2 Cool	•	•	•					•	•	•	•	•
 Wireless FocusPRO® 6000 Programmable	TH6320R1004	5-1-1/5-2	•	•	•		Soft Keys	Up to 3 Heat/2 Cool	•	•						•	•	•	•	•
 FocusPRO® 6000 Programmable	TH6110D1005	5-1-1/5-2	•	•	•		Soft Keys	1 Heat/1 Cool	•	•	•					•	•	•	•	•
	TH6110D1021	5-1-1/5-2	•	•	•		Soft Keys	1 Heat/1 Cool	•	•	•					•	•	•	•	•
	TH6220D1002	5-1-1/5-2	•	•	•		Soft Keys	Up to 2 Heat/2 Cool	•	•	•					•	•	•	•	•
	TH6220D1028	5-1-1/5-2	•	•	•		Soft Keys	Up to 2 Heat/2 Cool	•	•	•					•	•	•	•	•
	TH6320U1000	5-1-1/5-2	•	•	•		Soft Keys	Up to 3 Heat/2 Cool	•	•	•					•	•	•	•	•
 PRO 4000 Programmable	TH4110D1007	5-2	•	•	•		Slide Switches	1 Heat/1 Cool	•	•	•					•	Manual	•		
	TH4210D1005	5-2	•	•	•		Slide Switches	2 Heat/1 Cool	•	•	•					•	Manual	•		
 Wireless FocusPRO® 5000 Non-Programmable	TH5320R1002			Non-Prog			Soft Keys	Up to 3 Heat/2 Cool	•	•										
 FocusPRO® 5000 Digital Non-Programmable	TH5110D1006			Non-Prog			Soft Keys	1 Heat/1 Cool	•	•	•									
	TH5110D1022			Non-Prog			Soft Keys	1 Heat/1 Cool	•	•	•									
	TH5220D1003			Non-Prog			Soft Keys	Up to 2 Heat/2 Cool	•	•	•									
	TH5220D1029			Non-Prog			Soft Keys	Up to 2 Heat/2 Cool	•	•	•									
	TH5320U1001			Non-Prog			Soft Keys	Up to 3 Heat/2 Cool	•	•	•									
 PRO 3000 Non-Programmable	TH3110D1008			Non-Prog			Slide Switches	1 Heat/1 Cool	•	•	•									
	TH3210D1004			Non-Prog			Slide Switches	2Heat/1 Cool	•	•	•									

FEATURES AND FUNCTIONS													DISPLAY INFORMATION	SERVICE REMINDERS	LIMITED WARRANTY	WIRING TERMINALS	UPGRADE CROSS-REFERENCE						
Programmable & Circulation Fan	Humidification Control	Dehumidification Control	Ventilation Control	Dual-Fuel Heat Pump Operation	Remote Locator	Advanced Dual-Fuel Heat-Pump Operation	Language Options	Outdoor Sensor	Indoor Sensor	High Definition (HD) Display	Standard Definition (SD) Display	Dealer Logo On Screen	Display Size (Viewable)	On-Demand Backlighting	Continuous Backlighting	Simultaneous Display of Room and Set Temperatures	Filter, Humidifier Pad, UV Lamp Replacement Reminders		Honeywell	White-Rodgers	Robertshaw®	Toteline®	Other
•	•	•	•	•	•	•	•	•	•	•	•	8 sq. in.	•	•	•	•	5 Year	C, R, Rc, W-O/B, W2-Aux/E, Y, Y2, G, L, K, HUM, HUM, DHM, DHM					
•	•	•	•	•		•		•	•			10 sq. in.	•	•	•	•	5 Year	1, 2, 3, C, R, Rc, Rh, W1-0/B, W2-AUX, W3-AUX2, Y, Y2, G, L, HUM 1, HUM 2, DHM 1, DHM 2, VNT 1, VNT 2, OUT 1, OUT 2, IN 1, IN 2, DATS 1, DATS 2	PC8900	1F95-1291, 1F95-391, 1F97-391	980112, 982512, 98511, 98651, 98701	P374-1600	Aprilaire® 8570
•								•	•			10 sq. in.	•	•	•	•	5 Year	R, Rc, W-O/B, Y, G, C, S1, S2	T8600, T8601, T8602	1F90-371, 1F96-344, 1F97-371, 1F97-1271, 1F97-1277	9700i, 970112	P274-1300, P374-1100	
•				•				•	•			10 sq. in.	•	•	•	•	5 Year	R, Rc, W-O/B, W2-AUX, Y, Y2, L, E, G, C, S1, S2	T8600, T8601, T8602, T8611, T8624	1F90, 1F92, 1F93, 1F94, 1F95, 1F96, 1F97, 1F95-1271, 1F95-1277	9700i, 970112, 972512	P274-1300, P374-1100, P374-1600, P286-1200, P286-1300	
•	•			•				•	•			10 sq. in.	•	•	•	•	5 Year	R, Rc, W-O/B, W2-AUX, Y, Y2, L, E, G, C, S1, S2			9700i, 970112, 972512	P274-1300, P374-1100, P374-1600, P374-2200, P286-1200, P286-1300	
					•			•				5.09 sq. in.	•	•			5 Year	Wireless with Equipment Interface Module or Wireless Adapter					
												3.75 sq. in.	•	•			5 Year	R, Rc, W-O/B, Y, G, C	T8000, T8001, T8002, T8112	1F80 series, 1F80-0471	RS5110, RS6110	P474-1050, P474-1035	
												5.09 sq. in.	•	•			5 Year	R, Rc, W-O/B, Y, G, C	T8000, T8001, T8002, T8112	1F80 series, 1F85-0471	RS5110, RS6110	P474-1050, P474-1035	
												3.75 sq. in.	•	•			5 Year	R, Rc, W-O/B, W2-AUX, Y, Y2-E, L, G, C	T8112, T8000, T8001, T8002, T8011, T8024	1F80, 1F81, 1F82, 1F85, 1F85-0471	RS5220, RS6220	P474-1050, P474-1035, P374-1000	
												5.09 sq. in.	•	•			5 Year	R, Rc, W-O/B, W2-AUX, Y, Y2-E, L, G, C	T8112, T8000, T8001, T8002, T8011, T8024	1F80, 1F81, 1F82, 1F85, 1F85-0471	RS5220, RS6220	P474-1050, P474-1035, P374-1000	
												5.09 sq. in.	•	•			5 Year	R, Rc, W-O/B, W2-AUX/E, Y, Y2, G, L, C	T8112, T8000, T8001, T8002, T8011, T8024	1F85-0471	RS5220, RS6220		
												1.73 sq. in.	•	•			5 Year	R, Rc, C, W, O, B, Y, G	T8112	1F78-151, 1F78H-151	RS3110, 8600 series, 9600 series	P474-1035	Breabum 5000; LUX PSP711, PSP600
												1.73 sq. in.	•	•			5 Year	R, C, Y, Aux, O, B, E, G, L	T8011R	1F72-151	RS3110, 8600 series, 9600 series	P474-1050	Breabum 5200; LUX PSPH521
												5.09 sq. in.	•	•			5 Year	Wireless with Equipment Interface Module or Wireless Adapter					
												1.95 sq. in.	•	•			5 Year	R, Rc, W-O/B, Y, G, C	T8501, T8400, T8401	1F86	8400, 8401, 9400, 9401, 9550	P474-0100, P474-0130	
												2.98 sq. in.	•	•			5 Year	R, Rc, W-O/B, Y, G, C	T8501, T8400, T8401	1F86	8400, 8401, 9400, 9401, 9550	P474-0100, P474-0130	
												3.75 sq. in.	•	•			5 Year	R, Rc, W-O/B, AUX-W2, Y, Y2-E, L, G, C	T8501, T8511, T8524, T8400, T8401, T8411, T8424	1F73, 1F83, 1F86, 1F89	8400, 8401, 8425, 9400, 9401, 9415, 9420, 9550, 9555, 9560	P474-0100, P474-0130	
												5.09 sq. in.	•	•			5 Year	R, Rc, W-O/B, AUX-W2, Y, Y2-E, L, G, C	T8501, T8511, T8524, T8400, T8401, T8411, T8424	1F73, 1F83, 1F86, 1F89	8400, 8401, 8425, 9400, 9401, 9415, 9420, 9550, 9555, 9560	P474-0100, P474-0130	
												5.09 sq. in.	•	•			5 Year	R, Rc, W-O/B, W2-AUX/E, Y, Y2, G, L, C	T8501, T8511, T8524, T8400, T8401, T8411, T8424				
												1.32 sq. in.	•	•			5 Year	R, Rc, C, W, O, B, Y, G	T8400, T8401	1F78-144	8400, 9500	P474-0130, P374-0200	Breabum 3000; LUX PDS100, PDS111, PDS150
												1.32 sq. in.	•	•			5 Year	R, C, Y, Aux, O, B, E, G, L	T8411R	1F79-111	8425, 9420	P374-0300/SV300, P474-0100	Breabum 3200; LUX PSDH105, PSDH121

RESIDENTIAL

VisionPRO™ IAQ Thermostats

Control comfort and Indoor Air Quality (IAQ) with Honeywell's VisionPRO™ IAQ Total Home Comfort System. VisionPRO IAQ eliminates the need for multiple controls in the living space by managing temperature, humidification, dehumidification, ventilation and air filtration – all from a single, effortless touchscreen control.

Everything you love about VisionPRO — Touchscreen, menu-driven programming, precise comfort control (+/-1° F), and a 5-Year Warranty.

Eliminate “Wall Clutter” — Represent the quality of your work with a single control on the wall.

Reduce Truck Stock — Installer setup options let you configure VisionPRO to be programmable OR non-programmable. Carry only one thermostat on the truck.



Smart Change/Check Reminders — Let customers know when to service or replace batteries, filters, UV bulbs (based on actual usage) and humidifier pads.

OR

Make More Money — Use VisionPRO IAQ as a way to sell more Indoor Air Quality. Customers can add system enhancements upfront, or choose to upgrade later. Either way, the control is wired and ready to go.

Universal “Open” Application — Works with almost every brand heating/cooling system.

VisionPRO IAQ Total Home Comfort System

Mnemonic Number	Honeywell Number	Description
THT02771	TH9421C1004	Thermostat Only
THT02617	YTH9421C1002	Thermostat and Equipment Interface Module
THT02741	YTH9421C1010	Thermostat, Equipment Interface Module and Outdoor Temperature Sensor
MOD001809	THM5421C1008	Equipment Interface Module Only

Networked Zoning Systems with VisionPRO IAQ

Mnemonic Number	Honeywell Number	Description
KIT15501	Y8835A1044	Networked Zoning Kit: Zone Panel and 2 Thermostats
PNL23687	W8835A1004	EnviraZone (3H/2C) Networked Zone Panel (Zoning Only)



3-Wire Communication — Only three wires from the thermostat to the Equipment Interface Module (EIM) or Zone Panel, makes even retrofit applications quick and easy.



Outdoor Temperature Sensor — Display the outdoor temperature at the thermostat. (50022037 required for use with the W8835 panel.)

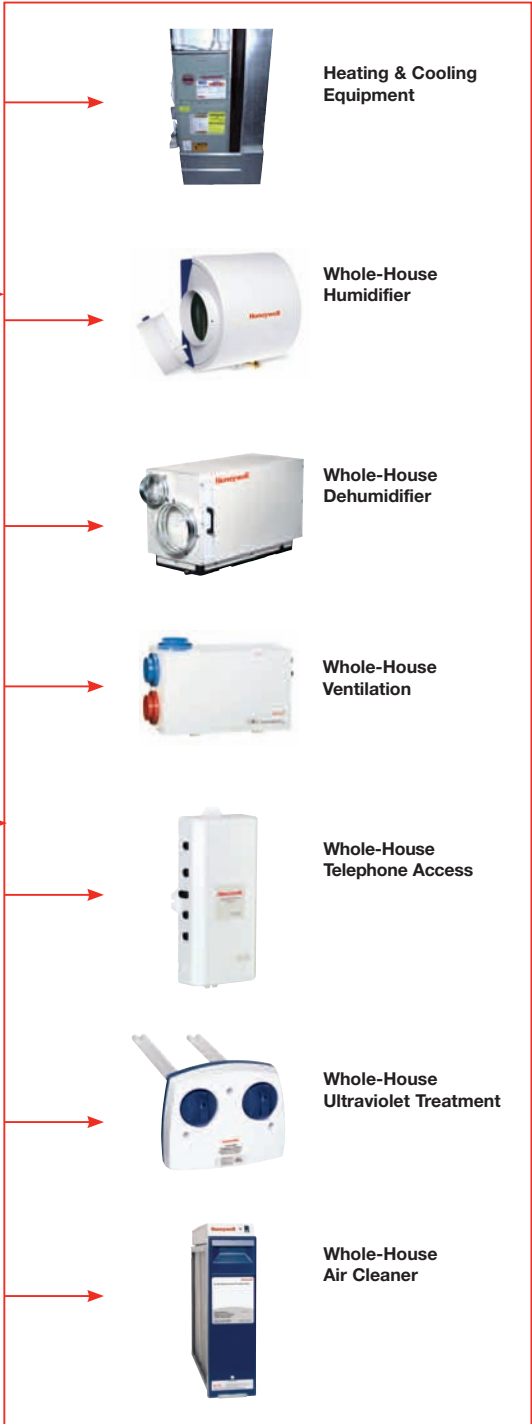

VisionPRO™ Thermostats

Finally, a programmable thermostat made effortless. Honeywell's VisionPRO thermostat has top-of-the-line features, and intuitive logic that makes programming easy for your customers (and reduces callbacks for you). VisionPRO's application flexibility makes it a perfect fit for nearly every system.

VisionPRO™ 8000 Touchscreen 7-Day Programmable Thermostat

MAXIMUM COMFORT AND ENERGY SAVINGS MADE EFFORTLESS.



- **Touchscreen Interaction**
- **Effortless, Menu-Driven Programming** — Simplifies programming by responding to your customers choices.
- **Energy Savings** — Customers can save up to 33% on annual heating and cooling costs.*
- **Large, Clear Backlit Digital Display** — Easy to read in various lighting conditions.
- **Real-Time Clock** — Keeps time during power failures and automatically updates for daylight savings.
- **Change/Check Reminders** — Let your customers know when to service or replace filters, batteries, etc.
- **Multiple HOLD Options** — Allows your customers to override the program schedule as desired with temporary and vacation hold settings.
- **Precise Comfort Control (+/-1°F)** — Maintains consistent comfort at the highest level of accuracy.
- **Programmable Fan** — Offers increased indoor air quality when combined with a Honeywell Whole-house Air Cleaner.
- **5-Year Warranty**

Mnemonic Number	Honeywell OS Number	Description
THT02455	TH8110U1003	1 Heat/1 Cool
THT02456	TH8320U1008	Up to 3 Heat/2 Cool
THT02491	TH8321U1006	Up to 3 Heat/2 Cool with Dehumidification

FocusPRO™ Thermostats

FocusPRO™ 6000 5-1-1 Day Programmable Thermostat

SIMPLICITY AND COMFORT THAT'S EASY TO SEE — AND EASY TO PROGRAM.

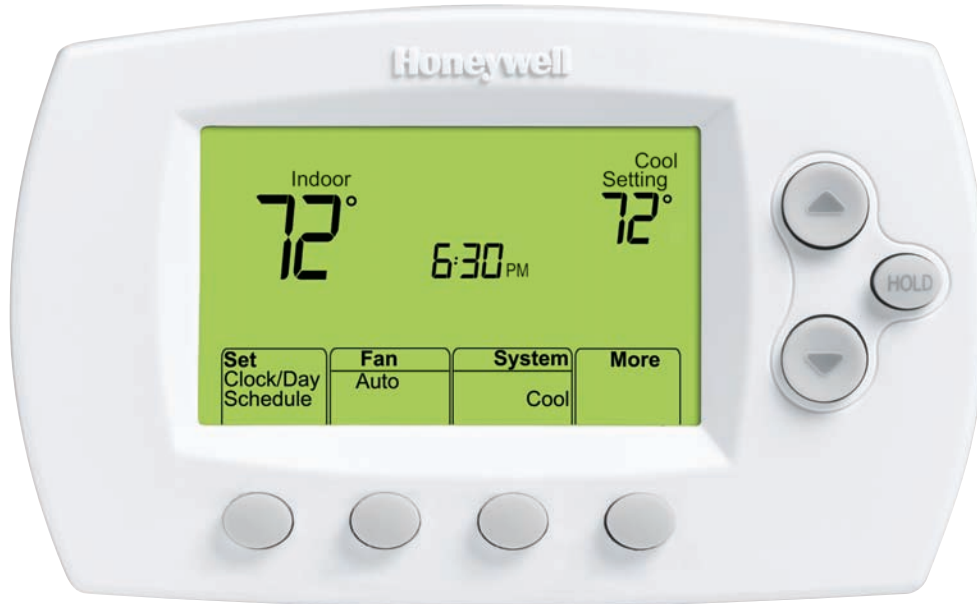

RESIDENTIAL

- **Large, Clear Backlit Digital Display** — Easy to read in various lighting conditions.
- **Weekday/Weekend Programming** — Your customers can use FocusPRO 6000 as a 5-1-1 (weekday, Saturday, Sunday) or 5-2 (weekdays, weekend) programmable thermostat – whichever best fits their lifestyle.
- **Energy Savings** — Customers can save up to 33% on annual heating and cooling costs.*
- **Built-In Instructions** — Simple, pull-out instructions.
- **Easy-Access Battery Replacement** — Flip-out door allows for easy battery replacement without removing or disassembling the thermostat.
- **Precise Comfort Control (+/-1°F)** — Maintains consistent comfort at the highest level of accuracy.
- **Display Size Options** — Available in large screen (shown) or standard.
- **RedLINK Wireless Models Available.**

Mnemonic Number	Honeywell OS Number	Description
THT02514	TH6110D1005	Programmable Small Screen 1 Heat/1 Cool
THT02512	TH6110D1021	Programmable Large Screen 1 Heat/1 Cool
THT02513	TH6220D1002	Programmable Small Screen Up to 2 Heat/2 Cool
THT02511	TH6220D1028	Programmable Large Screen Up to 2 Heat/2 Cool
THT02626	TH6320U1000	Programmable Large Screen Up to 3 Heat/2 Cool

FocusPRO™ Thermostats

FocusPRO™ 5000 Digital Non-Programmable Thermostat

SIMPLICITY AND COMFORT THAT'S EASY TO SEE.

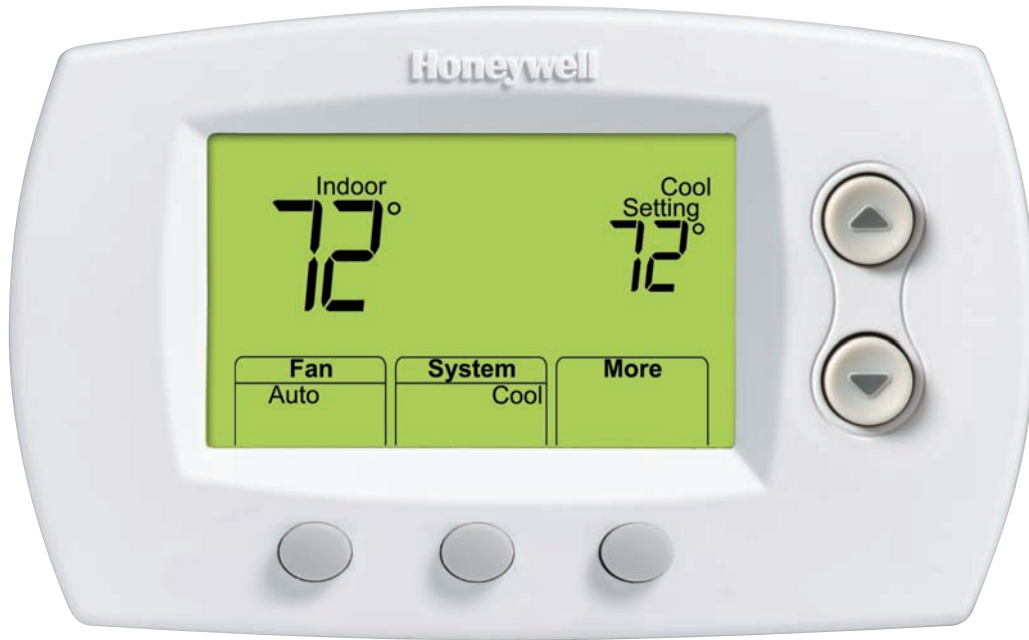

- **Large, Clear Backlit Digital Display** — Easy to read in various lighting conditions
- **Easy-Access Battery Replacement** — Flip-out door allows for easy battery replacement without removing or disassembling the thermostat
- **Precise Comfort Control (+/-1°F)** — Maintains consistent comfort at the highest level of accuracy
- **Display Size Options** — Available in large screen (shown) or standard

Mnemonic Number	Honeywell OS Number	Description
THT02487	TH5110D1006	Non-Programmable Small Screen 1 Heat/1 Cool
THT02488	TH5110D1022	Non-Programmable Large Screen 1 Heat/1 Cool
THT02532	TH5220D1029	Non-Programmable Small Screen Up to 3 Heat/2 Cool
THT02625	TH5320U1001	Non-Programmable Large Screen Up to 3 Heat/2 Cool

PRO Thermostats

When you are unable to sell homeowners the added benefits of a full-featured thermostat, Honeywell offers our PRO series of basic programmable and non-programmable thermostats with the features and control performance you can expect from the Honeywell name.

PRO 4000 5-2 Day Programmable Thermostat

MAXIMUM COMFORT AND ENERGY SAVINGS MADE EFFORTLESS.

- **Weekday/Weekend Programming — 5-2 (weekdays, weekend) programming to fit your customers lifestyle.**
- **Energy Savings — Customers can save up to 33% on annual heating and cooling costs.***
- **Digital Display — Both current and set temperature are easy to read in various lighting conditions.**
- **Built-In Instructions — Simple, pull-out instructions.**
- **Basic Operation — Easy-to-use slide switches allow your customers to select the heat or cool mode and adjust the fan.**
- **Precise Comfort Control (+/-1°F) — Maintains consistent comfort at the highest level of accuracy.**

5-Year Warranty



RESIDENTIAL

PRO 3000 Non-Programmable Thermostat

BASIC COMFORT.

- **Digital Display — Both current and set temperature are easy to read in various lighting conditions.**
- **Basic Operation — Easy-to-use slide switches allow your customers to select the heat or cool mode and adjust the fan.**
- **Precise Comfort Control (+/-1°F) — Maintains consistent comfort at the highest level of accuracy.**
- **5-Year Warranty**



Mnemonic Number	Honeywell OS Number	Description
THT02577	TH4110D1007	Programmable 1 Heat/1 Cool
THT02578	TH4210D1005	Programmable Up to 2 Heat/1 Cool
THT02575	TH3110D1008	Non-Programmable 1 Heat/1 Cool
THT02576	TH3210D1004	Non-Programmable Up to 2 Heat/1 Cool

Thermostat Private Label Program

- Give your customers the quality and reliability of a Honeywell thermostat.
- Let customers know who to call for future HVAC needs.
- Up to three full lines of personalization – imprinted directly on the thermostat cover.
- Low minimum order quantities – starting at just 48 units (may be combination of 24 units each of two products).
- Reorders – 24 units (must be of one product).
- No annual volume commitments.
- Fastest turn-times in the industry – imprint approval in 5 days or less, all orders shipped in 10 days or less*.

*Provided all program conditions are met. Based on product availability.









PROGRAM DETAILS

	Min. order quantity*	SET UP**	IMPRINT FEE
Initial Orders	48 Units	<ul style="list-style-type: none"> • Fax Setup \$75 • FREE through Website http://customer.honeywell.com 	None
Re-orders	24 Units		None

*ORDER MULTIPLES OF 12. FOR EXAMPLE: 48, 60, 72 UNITS.

**ONE-TIME SET UP

AVAILABLE ON THE FOLLOWING HONEYWELL PRODUCTS/PART NUMBERS:

RESIDENTIAL THERMOSTATS		RESIDENTIAL THERMOSTATS (CONTINUED)		
VisionPRO THERMOSTATS		PRO THERMOSTATS		
	VisionPRO IAQ: YTH9421C1002 (TH9421C1004 & THM5421C1008)		PRO 4000: TH4210D1005	
	VisionPRO IAQ: TH9421C1004		PRO 4000: TH4110D1007	
	VisionPRO 8000: TH8321U1006		PRO 3000: TH3210D1004	
	VisionPRO 8000: TH8320U1008		PRO 3000: TH3110D1008	
	VisionPRO 8000: TH8110U1003			
FocusPRO THERMOSTATS		COMMERCIAL THERMOSTATS		
THERMOSTATS		THERMOSTATS		
	FocusPRO 6000 - Large Screen: TH6320U1000		TB8220U1003	
	FocusPRO 6000 - Large Screen: TH6220D1028		TB7220U1012	
	FocusPRO 6000 - Standard Screen: TH6220D1002		TB7100A1000	
	FocusPRO 6000 - Large Screen: TH6110D1021			
	FocusPRO 6000 - Standard Screen: TH6110D1005			
	FocusPRO 5000 - Large Screen: TH5320U1001		SENSORS	
	FocusPRO 5000 - Large Screen: TH5220D1029		TR21	
	FocusPRO 5000 - Standard Screen: TH5220D1003		TR21-A	
	FocusPRO 5000 - Large Screen: TH5110D1022		TR21-J	TR22
	FocusPRO 5000 - Standard Screen: TH5110D1006		TR23	

Free Literature Program

Free Literature Program

Ordering your free literature is easy.
Just follow these simple steps:

Step 1

Go to <http://www.honeywell.literature.com>

To get 40 free pieces of literature a day, Canadian customers must select from the free catalog sections. The two sections are “Free Sell Sheets” and “Free Custom Sell Sheets”.



Step 2

The form numbers for free literature will end in **NC** or **VNC**.
The price will show \$0.00 in the shopping cart.



Please be advised you can only order 2-packs of 20 pieces or 1 pack of 40 pieces.

Step 3

When the order is just for free literature, click Next on the Payment Information page. Do not click “Purchase with Credit Card” or “Purchase with Account Balance”.

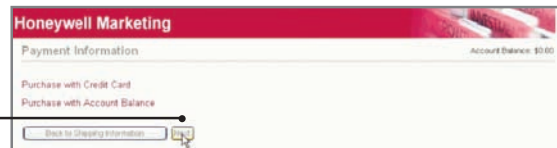

Step 4

The order confirmation page will show the total price was \$0.00 on the free literature.

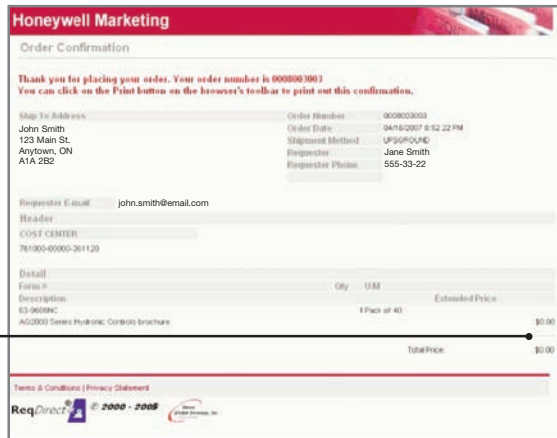

Step 5

Congratulations!

Your order will be shipped in 3-4 business days.

Learn More

Call toll-free **1-800-328-5111**,
e-mail **info@honeywell.com**,
or visit **forwardthinking.honeywell.com**
and **beyondinnovation.honeywell.com**.

Automation and Control Solutions

In the U.S.:
Honeywell
1985 Douglas Drive North
Golden Valley, MN 55422-3992

In Canada:
Honeywell Limited
35 Dynamic Drive
Toronto, Ontario M1V 4Z9
www.honeywell.com



Honeywell