



MovinCool®

The #1 spot cooling solution



MovinCool—Pioneering Spot Air Conditioners Since 1982

Welcome to MovinCool, your solution for quality portable and ceiling-mount spot air conditioners. Ever since developing the original spot air conditioner in 1982, MovinCool has been redefining the industry and introducing innovative, cost-effective cooling solutions to you. From the Classic, Classic Plus and Office Pro® Series to the latest Ceiling-Mount Series, MovinCool is dedicated to being the best cooling solution for your heat-management needs.

MovinCool was established to develop portable spot air conditioning systems for its parent company, DENSO Corporation. A leading component supplier to virtually all of the world's major automotive manufacturers—including Chrysler, Ford, GM, Honda and Toyota—DENSO employs 130,000 people in 38 countries throughout the world.

The first MovinCool portable spot air conditioners were so effective in DENSO factories and plants that the company decided to make them available commercially. Filling a critical need for spot cooling, MovinCool units were soon being put to effective use in a wide array of demanding manufacturing environments throughout North America.

Today, as manufacturing, telecom, computer and office-equipment demands evolve at record speed, MovinCool spot air conditioners are keeping pace. Delivering cooling solutions that are more versatile, more efficient and more cost-effective than ever before.

To meet our stringent MovinCool quality-control standards, we require that every unit we sell pass a demanding battery of performance tests. Then we back each one with the strongest, most comprehensive warranty in the industry.



Office Pro® Series

The Office Pro® is designed to function in today's information critical office environments. Its modern styling allows it to blend with most interiors yet it offers the same cooling power as our Classic industrial models. By cooling down to 65° F, the Office Pro® Series is ideal for cooling electronic equipment.

With programmable electronic temperature control, the Office Pro® is affordable insurance when the fixed air conditioning system is no longer sufficient or completely fails. The Office Pro® cools people and electronic equipment instantly, quietly, and efficiently.

For spaces where hot air cannot be exhausted, we now offer a 1.5 ton, 115V water-cooled model.

Key Features

- Air or Water-Cooled Models Available
- 24/7 Programmable Operating Modes
- Digital Temperature Control
- Provides Cooling in the Mid-60's ° F
- No Costly Installation Necessary

Where It's Used

- Server & Telecom Rooms
- Hospitals
- Laboratories
- Offices
- Schools
- Banks
- Emergency Back-up
- Supplemental Cooling
- After-hours Cooling



Office Pro® Series Specifications

MOVINCOOL
THE #1 SPOT COOLING SOLUTION



MovinCool Technical Specifications		Office Pro® 12	Office Pro® 18
Electronic Features	Control	Programmable	Programmable
Cooling Capacity	Rating conditions: 95° F at 60% RH	12,000 Btu/h	16,800 Btu/h
Electrical Characteristics	Voltage Requirement	1 Phase, 115V	1 Phase, 115V
	Total Power Consumption	1.3 kW	1.7 kW
	Current Consumption	11.9 amps	15.6 amps
	Recommended Fuse Size	15 amps	20 amps
	NEMA Plug Configuration	5 – 15	5 – 20
	Min. – Max. Voltage	105 – 125	105 – 125
Fans	Motor Output – high/low	0.14/0.08 kW	0.24/0.17 kW
Evaporator	Fan Type	Centrifugal	Centrifugal
	Max. Air Flow – high/low	410/380 CFM	540/500 CFM
	Max. External Static Pressure	0.31 IWG	0.31 IWG
Condenser	Fan Type	Centrifugal	Centrifugal
	Max. Air Flow – high/low	820/715 CFM	770/710 CFM
	Max. External Static Pressure	0.16 IWG	0.23 IWG
Compressor	Type	Hermetic Rotary	Hermetic Rotary
	Output	0.9 kW	1.16 kW
Refrigerant	Type	R-410A	R-410A
Dimensions	W x D x H	21 x 27 x 44 in	21 x 27 x 44 in
Net Weight/Shipping Weight		151/182 lb	170/201 lb
Power Cord	Gauge	14 AWG (3-core)	12 AWG (3-core)
	Length	10 ft	10 ft
Condensate Tank Capacity		5 gal	5 gal
Operating Conditions	Min. – Max. (@ 50% RH)	65° – 95° F	65° – 95° F
Max. Equivalent Duct Length	Per Cold Duct Hose	30 ft	25 ft
	Hot Duct Hose	60 ft	100 ft
Max. Sound Level	With Condenser Duct – high/low	52/50 dB(A)	61/59 dB(A)
	Without Condenser Duct – high/low	55/53 dB(A)	62/60 dB(A)



All specifications subject to change without notice. Standard warranty includes 12 months on entire unit and compressor. Visit www.MovinCool.com/reg for details on MovinCool's industry-best free Extended Warranty Program which includes 3 years for portable models and 2 years for ceiling-mount models for both parts and labor on units. All models feature compressor overload relay and fan motor protection. All models also feature compressor short-cycle protection, return air thermostat, automatic restart and accommodate a condensate pump kit. All models are 50 Hertz (Hz) compatible with a slight performance decrease from specifications listed above (except CM25 and CMW30).

* Specification information shown with 230V
(1) Rating Conditions: Air: 80°F at 50% RH / Water (EWT/LWT): 85°F/95°F

Water cooled



Office Pro® W20	Office Pro® 24*	Office Pro® 36*	Office Pro® 60*	Office Pro® 63
Programmable	Programmable	Programmable	Programmable	Programmable
15,700 Btu/h ⁽¹⁾	24,000 Btu/h	36,000 Btu/h	60,000 Btu/h	60,000 Btu/h
1 Phase, 115V	1 Phase, 208/230V	1 Phase, 208/230V	1 Phase, 208/230V	3 Phase, 460V
1.27 kW	2.9 kW	4.3 kW	6.6 kW	6.6 kW
11.7 amps	13.2 amps	19.6 amps	29 amps	9.5 amps
15 amps	20 amps	30 amps	50 amps	20 amps
5 – 15	6 – 20	6 – 30	6 – 50	L16 – 20
105 – 125	198 – 250	198 – 250	198 – 250	440 – 480
0.11/0.08 kW	0.57/0.40 kW	0.21/0.13 kW Evap.	0.5/0.33 kW Evap.	0.5/0.33 kW Evap.
		0.33/0.12 kW Cond.	1.2/0.93 kW Cond.	1.2/0.93 kW Cond.
Centrifugal	Centrifugal	Centrifugal	Centrifugal	Centrifugal
565/540 CFM	630/545 CFM	990/825 CFM	1940/1770 CFM	1940/1770 CFM
0.31 IWG	0.5 IWG	0.6 IWG	0.9 IWG	0.9 IWG
Water Cool Condenser	Centrifugal	Centrifugal	Centrifugal	Centrifugal
N/A	870/760 CFM	1490/1060 CFM	2830/2650 CFM	2830/2650 CFM
N/A	0.16 IWG	0.5 IWG	0.85 IWG	0.85 IWG
Hermetic Rotary	Hermetic Rotary	Hermetic Scroll	Hermetic Scroll	Hermetic Scroll
1.16 kW	1.8 kW	2.3 kW	3.9 kW	3.3 kW
R-410A	R-410A	R-410A	R-410A	R-410A
21 x 27 x 41.5 in	21 x 27 x 49 in	30 x 40 x 52 in	30 x 52 x 65 in	30 x 52 x 65 in
178/209 lb	216/253 lb	432/509 lb	623/753 lb	705/835 lb
14 AWG (3-core)	12 AWG (3-core)	12 AWG (3-core)	6 AWG (3-core)	12 AWG (4-core)
10 ft	6 ft	6 ft	6 ft	6 ft
5 gal	5 gal	2 @ 5 gal	Auto Pump Included	Auto Pump Included
65° – 95° F	65° – 95° F	65° – 95° F	65° – 105° F	65° – 105° F
40° – 90° F (Condenser water)				
25 ft	50 ft	40 ft	40 ft	40 ft
N/A	45 ft	60 ft	100 ft	100 ft
N/A	63/61 dB(A)	65/62 dB(A)	69/67 dB(A)	69/67 dB(A)
62/60 dB(A)	65/63 dB(A)	67/66 dB(A)	71/69 dB(A)	71/69 dB(A)

Office Pro® Series

Spot Cooling Solutions with MovinCool Accessories

The all-in-one design of MovinCool air conditioners make them the ideal cooling solution for virtually any heat-related problem. Using the optional accessories not only gives you the ability to customize the cooling application, but also makes the unit work more efficiently. In this catalog, we've grouped the accessories into the most common applications such as cooling multiple areas with one unit, automatically removing condensation and removing condenser heat. The possibilities are endless. And with genuine MovinCool accessories, you are assured of quality parts engineered and designed specifically to gain optimum performance from your MovinCool spot air conditioner.

How to select MovinCool accessories

The most common accessory installations are included in this catalog.

1. Find your MovinCool model category: Ceiling-Mount, Office Pro®, Classic Plus, or Classic.
2. Find the application(s) suited to your specific need.
3. Order the part number(s) for your specific MovinCool model.

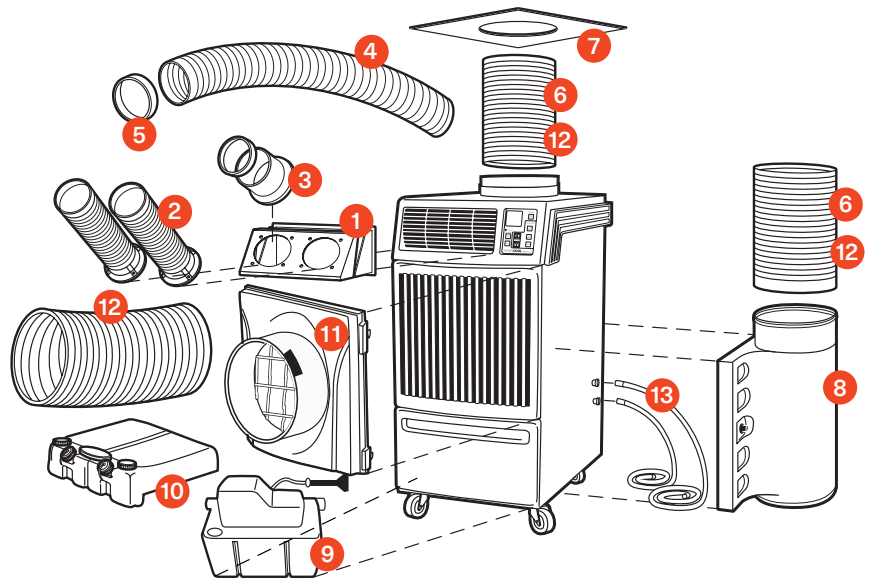

Individual part descriptions for MovinCool Office Pro® Series

1	Nozzle Adapter Kit	Two-piece metal frame converts airflow from louvers to nozzles or cold air ducts. Includes mounting screws. (Nozzles and ducts sold separately)
1A	Duct Adapter Kit (Not shown)	Same as above, but for use with cold air flexible ducts. Includes flange. Use on Office Pro® 36 or 60/63 only. (Cold air flexible ducts sold separately)
2	Nozzle Kit	5" or 6" diameter white plastic nozzle that extends up to 2' in length. Includes flange, mounting screws and trim ring. (Sold individually)
3	Cold Air Flange Kit	5" or 6" diameter white metal flange with wire clamp and mounting screws. Use with cold air ducts.
4	Cold Air Self-Supported Duct	5", 6" or 8" adjustable diameter, white polypropylene duct that extends from 6-½' to 10' in length.
4A	Cold Air Flexible Duct (Not shown)	8" diameter wire-reinforced, accordion-style duct in 25' lengths. (For Office Pro® 36 & 60/63 only)
5	Trim Ring	5" or 6" diameter black end-cap for cold air self-supported duct.
6	Warm Air Self-Supported Duct	12" diameter white, polypropylene plastic duct that extends 6-½' to 10' in length. (N/A for Office Pro® 36 exhaust and entire Office Pro® 60/63)
7	Ceiling Tile	24" x 24" white tile with 12" hole for warm air self-supported duct. (24" x 24" sheet metal tile with 16" hole and built-in flange and tie-strap for Office Pro® 36 exhaust and entire Office Pro® 60/63)
8	Condenser Air Plenum	White plastic plenum for return air to condenser. Hinged for filter cleaning.
9	Condensate Pump Kit	110V or 220V pump kit includes ¾" diameter x 20' length clear vinyl hose and installation hardware.
10	Condensate Tank	Drain tank storage for condensation. Requires condensate float, sold separately. (For Office Pro® 60/63 only)
10A	Condensate Float (Not shown)	Controls water level in condensate tanks. (For Office Pro® 60/63 only)
11	Evaporator Air Plenum	White plastic plenum for return air to evaporator. (For Office Pro® 60/63 only)
12	Warm Air Flexible Duct Kit	12" diameter wire-reinforced, accordion-style duct in 10' lengths for condenser exhaust. Includes clamp. Duct is 16" in diameter and 25' in length for Office Pro® 36 exhaust and entire Office Pro® 60/63 only.
13	Hose Kit	Two 25' hoses for condenser water supply and return. (For Office Pro® W20 only)

Accessories



Auto condensate removal: Why bother with emptying the drain tank when you can install a condensate pump to remove the water automatically? This pump has a 17-foot lift capacity to reach virtually any remote drain.

#	Part name	Office Pro® 12 & 18	Office Pro® W20	Office Pro® 24	Office Pro® 36	Office Pro® 60 & 63
9	Condensate Pump Kit	LA484789-0080	LA484789-0080	LA484789-0090	LA484789-0090	Included
10	Condensate Tank	Included	Included	Included	Included	484730-0010
10A	Condensate Float (Not shown) ^(a)	N/A	N/A	N/A	Included	484460-0010



Condenser heat removal: MovinCool makes removing exhaust easy. For air-cooled models, simply replace the existing ceiling tile with the MovinCool ceiling tile accessory. Place the self-supported or flexible duct on top of the unit and insert it into the ceiling tile. For water-cooled models, simply connect water supply and return with hose kit. That's all it takes.

#	Part name	Office Pro® 12 & 18	Office Pro® W20	Office Pro® 24	Office Pro® 36	Office Pro® 60 & 63
6	Warm Air Self-Supported Duct	481744-0060	N/A	481744-0060	N/A	N/A
12	Warm Air Flexible Duct Kit	LAY45771-0060 ⁽ⁱ⁾	N/A	LAY45771-0060 ⁽ⁱ⁾	LAY45820-0010	LAY45820-0010
7	Ceiling Tile ^(b)	LA146373-8280	N/A	LA146373-8280	GX484410-8940	GX484410-8940
13	Hose Kit	N/A	GX484009-0920	N/A	N/A	N/A



Condenser air intake: When balanced airflow is required, attach the air plenum with a duct from the side of the unit to an outside air source. The air to the condenser is pulled from outside the room to eliminate problems associated with negative air pressure.

#	Part name	Office Pro® 12 & 18	Office Pro® W20	Office Pro® 24	Office Pro® 36	Office Pro® 60 & 63
6	Warm Air Self-Supported Duct	481744-0060	N/A	481744-0060	N/A	N/A
12	Warm Air Flexible Duct Kit	LAY45771-0060 ⁽ⁱ⁾	N/A	LAY45771-0060 ⁽ⁱ⁾	LAY45820-0010	LAY45820-0010
7	Ceiling Tile ^(b)	LA146373-8280	N/A	LA146373-8280	GX484410-8940	GX484410-8940
13	Hose Kit	N/A	GX484009-0920	N/A	N/A	N/A



Spot or remote cooling: To use the Office Pro® to spot cool specific areas, use the nozzle adapter in place of the standard louvers. Attach cold air ducts to the adapter to cool remote hot spots. Trim rings give a finished look and keep the ducts from unraveling. To improve efficiency, use the evaporator air plenum to recirculate cool air.

#	Part name	Office Pro® 12 & 18	Office Pro® W20	Office Pro® 24	Office Pro® 36	Office Pro® 60 & 63
1	Nozzle Adapter Kit	LA481769-0170	LA481769-0170	LAY84209-0010	LAY45770-0070 (6") ^(k)	LAY45770-0070 (6") ^(k)
1A	Duct Adapter Kit	N/A	N/A	N/A	LAY45770-0080 (8") ^(l)	LAY45770-0080 (8") ^(l)
2	Nozzle Kit ^(c)	LAY84209-0030	LAY84209-0030	484209-0050	484209-0050 (6")	484209-0050 (6")
3	Cold Air Flange Kit* ^(c)	481170-0180	481170-0180	481170-0250	481170-0250 (6")	481170-0250 (6")
4	Cold Air Self-Supported Duct* ^(d)	481744-0090	481744-0090	481744-0030	481744-0030 (6") LAY45810-0080 (8") ^(g)	481744-0030 (6") LAY45810-0080 (8") ^(g)
4A	Cold Air Flexible Duct* ^(e)	N/A	N/A	N/A	LAY45810-0030 (8")	LAY45810-0030 (8")
5	Trim Ring ^(e)	481851-0200	481851-0200	481851-0210	481851-0210 (6")	481851-0210 (6")
11	Evaporator Air Plenum ^(f)	N/A	N/A	N/A	N/A	LAY84270-0070

NOTE: All part numbers come with one part except where noted. All kits include additional pieces such as clamps and screws. See parts description box for more information.

* Order 1 or 2 parts depending if 1 or 2 nozzles, flanges or ducts are needed.

- (a) #10 is required
- (b) #6 or 12 is required.
- (c) #1 is required
- (d) #1 & 3 are required
- (e) #1, 3 & 4 are required
- (f) #12 is required for Office Pro 60/63 only

- (g) #1A is required for Office Pro 36 & 60/63 only
- (h) #6 & 8 are required
- (i) If using with #7, part #481170-0190 is required.
- (j) If using with #7, part #481170-0190 & #8 are required.
- (k) Requires 4 nozzles or 4 flange kits and ducts.
- (l) #4 or 4A is required

Classic Plus Series

The Classic Plus Series cools down harsh industrial, warehouse environments just like its predecessor, the original MovinCool Classic. But, unlike the Classic Series, the Classic Plus offers the added advantage of programmable temperature control and a wider range of operating temperatures. The Classic Plus also requires little or no installation, making these versatile models ready to bring instant cooling relief to the hottest spots. Simply roll it in, plug it in and turn it on!

Key Features

- 24/7 Programmable Operating Modes
- Digital Temperature Control
- Two-Speed Fan
- Handles Temperatures up to 113° F
- Adjustable Nozzles to Direct Cooling on Critical Hot Spots

Where It's Used

- Warehouses
- Assembly Lines
- Manufacturing Plants
- Process Cooling
- Moisture Removal
- Outdoors and Events



Classic Plus Series Specifications

MOVINCOOL
THE #1 SPOT COOLING SOLUTION



MovinCool™ technical specifications		Classic 10	Classic Plus 14	Classic Plus 26*
Electronic Features	Control	Digital	Programmable	Programmable
Cooling Capacity	Rating conditions: 95°F at 60% RH	10,000 Btu/h	13,200 Btu/h	24,000 Btu/h
Electrical Characteristics	Voltage Requirement	1 Phase, 115V	1 Phase, 115V	1 Phase, 208/230V
	Total Power Consumption	1.1 kW	1.3 kW	2.4 kW
	Current Consumption	10 amps	11.9 amps	10.8 amps
	Recommended Fuse Size	15 amps	15 amps	20 amps
	NEMA Plug Configuration	5-15	5-15	6-20
	Min. – Max. Voltage	105 – 125	105 – 125	198 – 250
Fans	Motor Output – high/low	0.15 kW	0.24/0.19 kW	0.55/0.38 kW
Evaporator	Fan Type	Centrifugal	Centrifugal	Centrifugal
	Max. Air Flow – high/low	265 CFM	440/380 CFM	708/600 CFM
	Max. External Static Pressure	0.33 IWG	0.31 IWG	0.42 IWG
Condenser	Fan Type	Centrifugal	Centrifugal	Centrifugal
	Max. Air Flow – high/low	740 CFM	880/760 CFM	1250/1190 CFM
	Max. External Static Pressure	0.13 IWG	0.19 IWG	0.25 IWG
Compressor	Type	Hermetic Rotary	Hermetic Rotary	Hermetic Scroll
	Output	0.7 kW	0.9 kW	1.5 kW
Refrigerant	Type	R-410A	R-410A	R-410A
Dimensions	W x D x H	19 x 26 x 41 in	19 x 26 x 41 in	19 x 29 x 47 in
Net Weight/Shipping Weight		156/194 lb	166/197 lb	199/270 lb
Power Cord	Gauge	14 AWG (3-core)	14 AWG (3-core)	12 AWG (3-core)
	Length	10 ft	10 ft	6 ft
Condensate Tank Capacity		5 gal	5 gal	5 gal
Operating Conditions	Min. – Max. (@ 50% RH)	70° – 105°F	70° – 113°F	70° – 113°F
Max. Equivalent Duct Length	Per Cold Duct Hose	40 ft	30 ft	60 ft
	Hot Duct Hose	60 ft	60 ft	45 ft
Max. Sound Level	With Condenser Duct – high/low	55 dB(A)	57/55 dB(A)	66/64 dB(A)
	Without Condenser Duct – high/low	58 dB(A)	60/58 dB(A)	69/67 dB(A)



All specifications subject to change without notice. Standard warranty includes 12 months on entire unit and compressor. Visit www.MovinCool.com/reg for details on MovinCool's industry-best free Extended Warranty Program which includes 3 years for portable models and 2 years for ceiling-mount models for both parts and labor on units. All models feature compressor overload relay and fan motor protection. All models also feature compressor short-cycle protection, return air thermostat, automatic restart and accommodate a condensate pump kit. All models are 50 Hertz (Hz) compatible with a slight performance decrease from specifications listed above (except CM25 and CMW30).

*Specification information shown with 230V

Accessories



Auto condensate removal: Why bother with emptying the drain tank when you can install a condensate pump to remove the water automatically? This pump has a 17-ft. lift capacity to reach virtually any remote drain. With the condensate pump installed, drainage is automatic and access to the compartment is no longer necessary. A cover plate can then be added to conceal and protect the pump.

#	Part name	Classic 10	Classic Plus 14	Classic Plus 26
9	Cover Plate	484009-0480	484009-0480	484009-0480
10	Condensate Pump Kit	LA484789-0121	LA484789-0080	LA484789-0090



Condenser air removal: To exhaust the warm condenser air above the work area, attach the warm air flange and duct to the top of the unit. When using MovinCool inside an office, simply replace the ceiling tile with the MovinCool ceiling tile and insert the duct to exhaust the warm air. No special tools or equipment are required for the installation.

#	Part name	Classic 10	Classic Plus 14	Classic Plus 26
5	Warm Air Flange Kit	481170-0191	481170-0191	481170-0191
6	Warm Air Duct ^(a)	481744-0060	481744-0060	481744-0060
7	Ceiling Tile ^(b)	LA146373-8280	LA146373-8280	LA146373-8280
11	Warm Air Flexible Duct Kit ^(c)	LAY45771-0060	LAY45771-0060	LAY45771-0060



Condenser air intake: When balanced air flow is required, attach the air plenum with a duct from the side of the unit to an outside air source. The air to the condenser is pulled from outside the room to eliminate problems associated with negative air pressure.

#	Part name	Classic 10	Classic Plus 14	Classic Plus 26
6	Air Duct ^(c)	481744-0060	481744-0060	481744-0060
7	Ceiling Tile ^(d)	LA146373-8280	LA146373-8280	LA146373-8280
8	Air Plenum	LAY84270-0040	LAY84270-0020	LAY84270-0030
11	Warm Air Flexible Duct Kit ^(h)	LAY45771-0060	LAY45771-0060	LAY45771-0060



Remote cooling: The amount of air supplied to remote areas can be quickly and conveniently increased by attaching 10-ft. extension ducts directly over the standard ducts. For more permanent installations, use the flange and clamp to secure the extension ducts to the unit. Each duct can be extended 30 to 60 feet from the unit, depending on the model. Add trim rings to the end of the extension ducts to give a finished look and keep the ducts from unraveling. The dual duct accessory can be used to divide each 5-inch nozzle opening into two 4-inch outlets to multiply your cooling options.

#	Part name	Classic 10	Classic Plus 14	Classic Plus 26
1	Cold Air Flange Kit	481170-0180	481170-0180	481170-0250
2	Extension Duct ^(e)	481744-0090	481744-0090	481744-0030
3	Trim Ring ^(f)	481851-0200	481851-0200	481851-0210
4	Dual Duct	484209-0030	484209-0030	N/A

(a) #5 is required

(b) #5 & 6 are required

(c) #8 is required

(d) #6 & 8 are required

(e) #1 is required

(f) #1 & 2 are required

(g) If using with #7, two #5's are required

(h) If using with #7, two #5's & one #8 are required

NOTE: All part numbers come with one part except where noted. All kits include additional pieces such as clamps and screws. See parts description box for more information

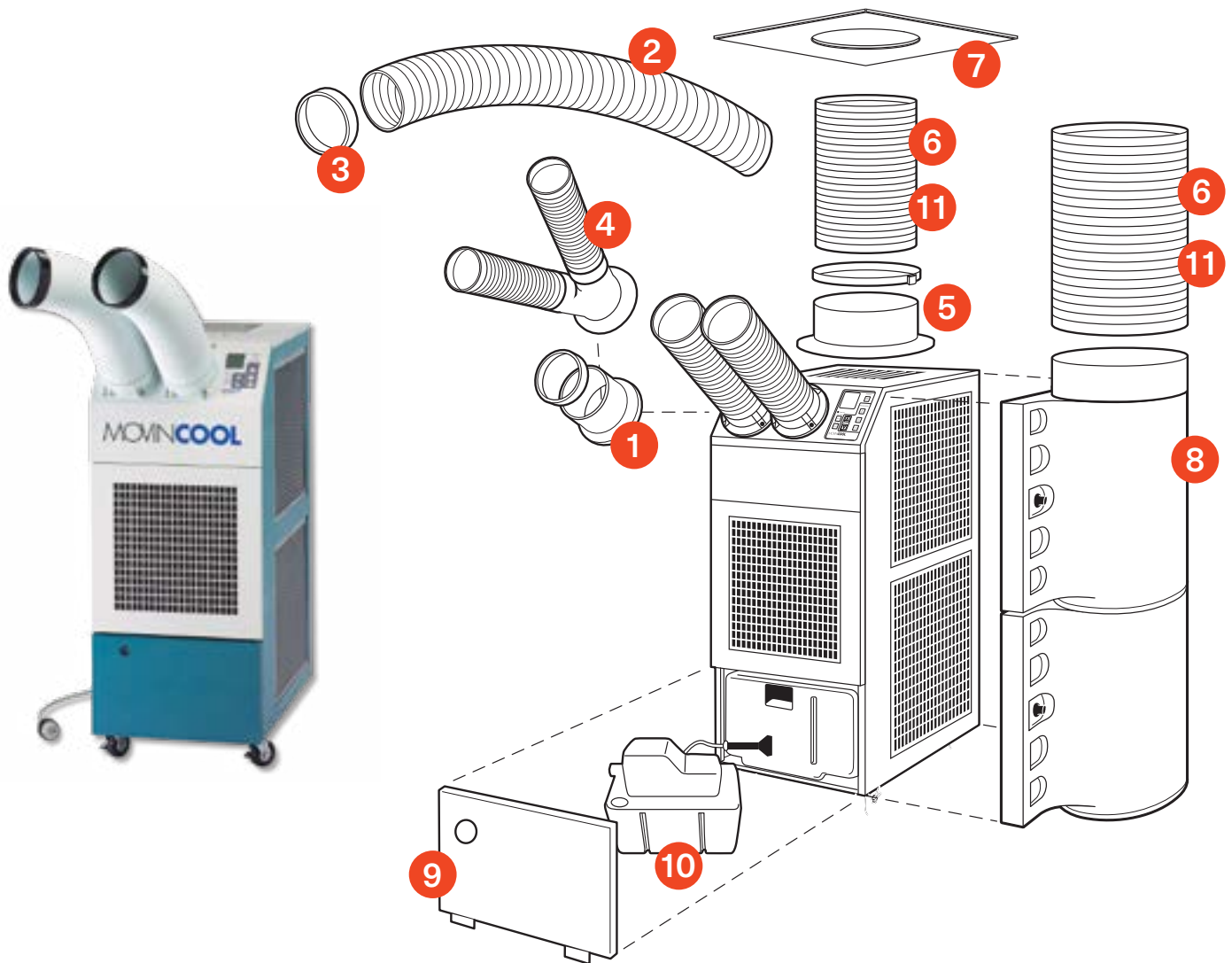

Individual part descriptions for MovinCool Classic/Classic Plus Series

1	Cold Air Flange Kit	5" or 6" diameter white metal flange with wire clamp and mounting screws.
2	Cold Air Extension Duct	5" or 6" diameter white plastic duct that extends from 6 ½' to 10' in length.
3	Trim Ring	5" or 6" diameter black plastic ring mounts as end caps for extension ducts.
4	Dual Duct	5" diameter white plastic flange with two 4" nozzles that extend to 2' in length.
5	Warm Air Flange Kit	12" diameter gray metal flange with wire clamp and mounting screws.
6	Warm Air Duct	12" adjustable diameter white plastic duct that extends from 6 ½' to 10' in length.
7	Ceiling Tile	24" x 24" white tile with 12" hole for warm air duct.
8	Air Plenum	White plastic plenum for return air to condenser. Hinged for filter cleaning.
9	Cover Plate	Blue metal plate covers condensate collection area.
10	Condensate Pump Kit	110V or 220V pump kit includes 3/8" diameter x 20' length hose and installation hardware.
11	Warm Air Flexible Duct Kit	12" diameter, wire-reinforced, accordion-style duct in 10' lengths for condenser exhaust. Includes clamp.

Classic Series

Time tested and proven, the Classic Series has been cooling the world's factories, warehouses and work places for over thirty years. The Classic's rugged design and unparalleled reliability has made it the unit of choice for production managers, quality engineers and warehouse operators. With powerful cooling capacities and many customized options, there is a Classic model for virtually every cooling need.

Key Features

- Digital Temperature Controls
- Rugged Design for Harsh Environments
- Maintenance-free Operation
- Totally Self-contained
- Customized Spot Cooling Options
- Up to 80 feet of Extension Ducting to Enable Remote Spot Cooling
- Safety Listed for Outdoor Use

Where It's Used

- Warehouses
- Assembly Lines
- Manufacturing Plants
- Process Cooling
- Moisture Removal
- Outdoors and Events



Classic Series Specifications

MOVINCOOL
THE #1 SPOT COOLING SOLUTION



MovinCool™ technical specifications		Classic 40	Classic 60
Electronic Features	Control	Digital	Digital
Cooling Capacity	Rating conditions: 95° F at 60% RH	39,000 Btu/h	60,000 Btu/h
Electrical Characteristics	Voltage Requirement	3 Phase, 220V	3 Phase, 460V
	Total Power Consumption	4.2 kW	5.9 kW
	Current Consumption	14 amps	8.8 amps
	Recommended Fuse Size	25 amps	20 amps
	NEMA Plug Configuration	L15-30	N/A
	Min. – Max. Voltage	198 – 240	440 – 480
Fans	Motor Output – high/low	0.75 kW Evap.	0.75 kW Evap.
		0.40 kW Cond.	0.40 kW Cond.
Evaporator	Fan Type	Centrifugal	Centrifugal
	Max. Air Flow – high/low	1060 CFM	1580 CFM
	Max. External Static Pressure	1.73 IWG	1.35 IWG
Condenser	Fan Type	Propeller	Propeller
	Max. Air Flow – high/low	2650 CFM	3800 CFM
	Max. External Static Pressure	0.05 IWG	0.05 IWG
Compressor	Type	Hermetic Scroll	Hermetic Scroll
	Output	2.3 kW	3.89 kW
Refrigerant	Type	R-410A	R-410A
Dimensions	W x D x H	26 x 44 x 38 in	32 x 49 x 42 in
Net Weight/Shipping Weight		344/396 lb	474/566 lb
Power Cord	Gauge	12 AWG (4-core)	N/A
	Length	6 ft	N/A
Condensate Tank Capacity		2 @ 5 gal (Optional)	N/A
Operating Conditions	Min. – Max. (@ 50% RH)	75° – 115° F	75° – 115° F
Max. Equivalent Duct Length	Per Cold Duct Hose	Varies	Varies
	Hot Duct Hose	40 ft	40 ft
Max. Sound Level	With Condenser Duct – high/low	N/A	N/A
	Without Condenser Duct – high/low	72 dB(A)	72 dB(A)



All specifications subject to change without notice. Standard warranty includes 12 months on entire unit and compressor. Visit www.MovinCool.com/reg for details on MovinCool's industry-best free Extended Warranty Program which includes 3 years for portable models and 2 years for ceiling-mount models for both parts and labor on units. All models feature compressor overload relay and fan motor protection. All models also feature compressor short-cycle protection, return air thermostat, automatic restart and accommodate a condensate pump kit. All models are 50 Hertz (Hz) compatible with a slight performance decrease from specifications listed above (except CM25 and CMW30).

Accessories



Multiple or remote area cooling: Cooling several hot spots is not a problem with the two- or three-way chamber. Extension ducts in 10-ft. sections can be used to bring cooling to remote or different locations. Attach trim rings at the end of the extension ducts to give a finished look and keep the ducts from unraveling.

#	Part name	Classic 40	Classic 60
1	Cold Air Flange Kit	481170-0191	481170-0191
2	Chamber Extender	481849-1431 ^(e)	481849-1431 ^(f)
2A	Chamber Extender Flange Kit*	481170-0091	481170-0091 ^(a)
3	Two-way Chamber	481769-0041	481769-0041 ^(a)
3A	Three-way Chamber (Not shown)	481769-0051	481769-0051 ^(a)
3B	Reducer Flange Kit	N/A	481170-0151
4	Extension Duct (6-inch) ^(b)	481744-0030	481744-0030
5	Trim Ring ^(c)	481851-0210	481851-0210
6	Extension Duct (12-inch) ^(d)	481744-0060	481744-0060



10A

Remote control: When the unit is installed in a remote location, such as outdoors or overhead, use the remote control to allow convenient access to controls. Part 10A is a weekday & weekend programmable digital millivolt thermostat. For part 10B, the kit includes the operational control, a cover plate to prevent tampering with controls, and installation hardware. Use six 18AWG plus one ground wire to connect the control to the unit.

(Wire not included)

#	Part name	Classic 40	Classic 60
10A	Wall Thermostat (For models manufactured after 2008)	LA484500-3430	LA484500-3430
10B	Remote Control Kit (For models manufactured up thru 2008)	484500-0431	484500-0431



10B

Portability: To allow portability of these high-capacity MovinCool units, use the caster kit or the wagon kit. The stand kit provides proper ground clearance for permanent exterior installations.

#	Part name	Classic 40	Classic 60
7	Stand kit	484750-0021	N/A
8	Wagon kit	484710-0022	N/A
9	Caster kit	484709-0011	484709-0020

(a) #3B is required for Classic 60 only

(b) #3 is required (order 2 or 3 ducts depending on chamber selected)

(c) #3 & 4 are required

(d) #1 is required

(e) #2A is required

(f) #2A & 3B are required for Classic 60 only

NOTE: All part numbers come with one part except where noted.

All kits include additional pieces such as clamps and screws.

See parts description box for more information.

* Must order quantity of 2 per each Chamber Extender used.

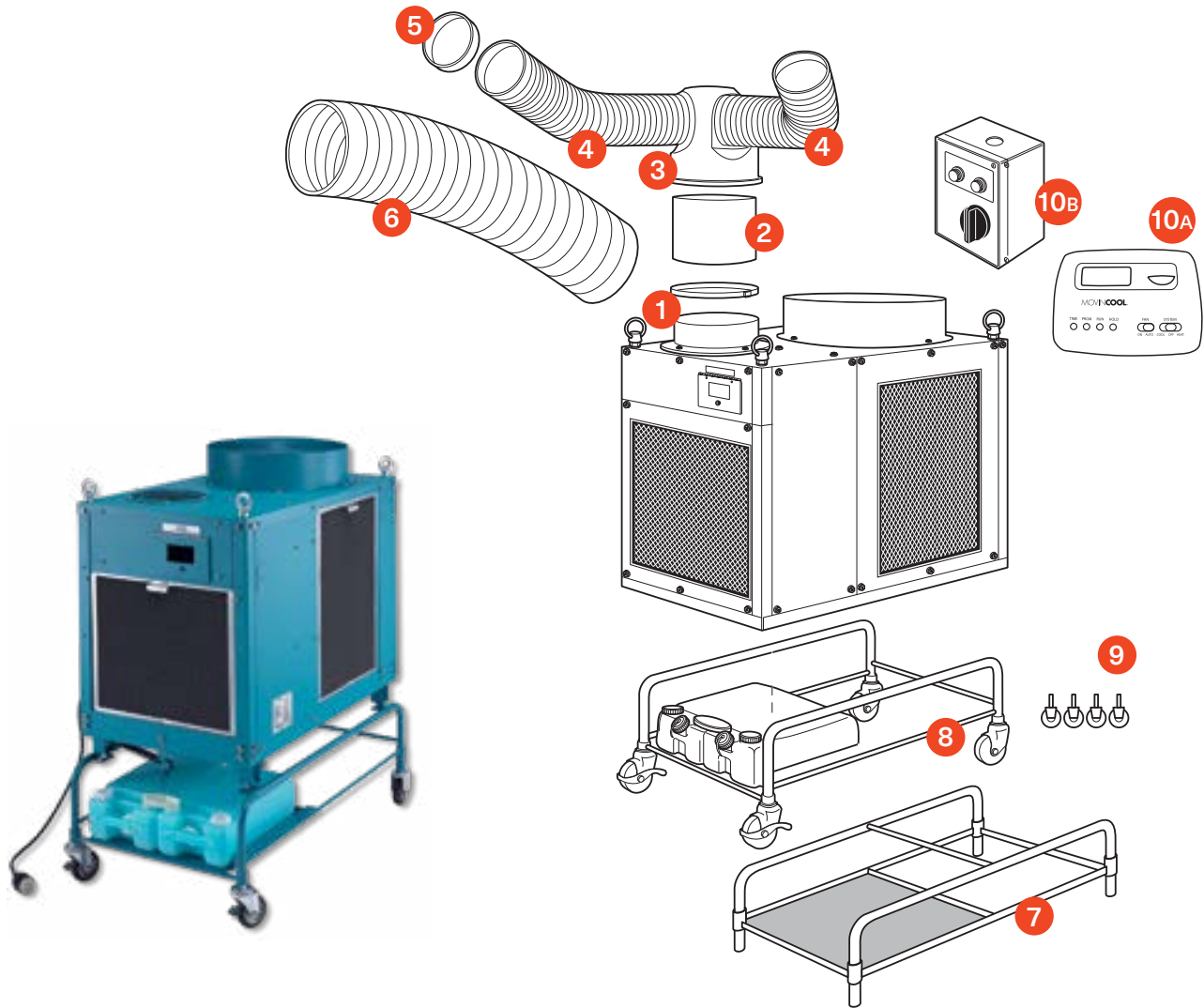

Individual part descriptions for MovinCool Classic 40/Classic 60

1	Cold air flange kit	12" diameter gray metal flange with wire clamp and mounting screws.
2	Chamber extender	Gray metal cylinder raises exhaust air chamber 16" above unit.
2A	Chamber extender flange kit	Gray metal flange connects chamber extender to unit. (Not shown)
3	Two-way chamber	Insulated gray plastic chamber diverts airflow in two directions. Use 6" extension ducts.
3A	Three-way chamber (not shown)	Diverts airflow in three directions. Use 6" extension ducts.
3B	Reducer flange kit (not shown)	Gray metal flange converts mounting holes on Classic 60 for two- or three-way chamber and chamber extender flange.
4	Extension duct	6" adjustable diameter white plastic duct that extends from 6 1/2' to 10' in length.
5	Trim ring	6" diameter black plastic end cap for extension duct.
6	Extension duct	12" adjustable diameter white plastic duct that extends from 6 1/2' to 10' in length.
7	Stand kit	Blue metal, tubular frame raises unit off the ground. (Available for Classic 40 only)
8	Wagon kit	Blue metal, tubular frame with four casters, drain spout assembly and two 5-gal. condensate tanks. (Available for Classic 40 only)
9	Caster kit	Four casters and wrench.
10A	Remote control kit	Weekday and weekend programmable digital millivolt thermostat.
10B	Remote control kit	Kit includes remote control box and installation hardware. Use six 18AWG plus one ground wire. (Wire not included)

Ceiling-Mount Series

The latest addition to the award-winning MovinCool line of spot coolers is the CM Series of ceiling-mount packaged air conditioners, including the air-cooled CM12 and CM25 models, as well as the new CMW30 water-cooled model.

Featuring the shortest top-to-bottom profile in the industry, the CM Series fits into virtually any drop ceiling, making it the perfect cooling solution for server rooms, which have limited floor space.

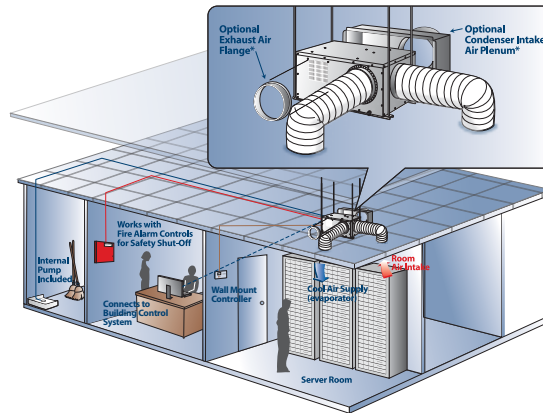

CM12 key features

- 10,500 Btu/h at 80°F 50% RH (evaporator)
95°F 50% RH (condenser)
- 13,000 Btu/h at 95°F 60% RH
- 115V, 15 amps—no special electric required
- No floor space needed
- Can fit into tight ceiling spaces

CM25 key features

- 25,000 Btu/h at 80°F 50% RH (evaporator)
95°F 50% RH (condenser)
- High sensible cooling at 18,900 Btu/h
- Environmentally-friendly design—14 SEER, variable-speed compressor, R-410A refrigerant and RoHS compliant
- Compact, self-contained unit is easy to install
- Wall mount controller offers advanced programmability and settings

CMW30 key features

- 29,400 Btu/h total cooling capacity
- 22,000 Btu/h sensible cooling for computer rooms
- Environmentally friendly design—17 IEER, R-410A refrigerant and RoHS compliant
- Low-cost installation using standard off-the-shelf hardware
- Wide condenser EWT range—45°F to 115°F

Where it's used

- Server rooms
- Telecom closets
- Off-season spot cooling
- Overhead spot cooling
- Supplemental cooling
- Hotels
- Anywhere space is limited



- A** Warning signals and audible alarms for condensation overflow
- B** Built-in flanges. Detachable flanges enable easy installation.**
- C** Inverter compressor*
- D** Wide operating range
- E** Built-in mounting brackets designed for off-the-shelf hardware
- F** Vibration isolator included*
- G** Built-in Condensate Pump
- H** Inverter fan motors*

**CM25 and CMW30 only
**CM25 only

Ceiling-Mount Series Specifications

MOVINCOOL
THE #1 SPOT COOLING SOLUTION



MovinCool™ technical specifications		CM12	CM25*	CMW30*
Electronic Features	Operation	Millivolt Thermostat (Not included)	Wall Mounted Controller	Wall Mounted Controller
	Control	Electronic	Programmable	Programmable
Electrical Characteristics	Voltage Requirement	115V, 1 Phase, 60 Hz	208/230V, 1 Phase, 60 Hz	208/230V, 1 Phase, 60 Hz
	Min. – Max. Voltage	105 – 125	198 – 250	198 – 250
	Recommended Fuse Size	15 amps	20 amps	20 amps
Cooling Capacity and Power Consumption				
Evaporator: 80° F, 50% RH	Total Cooling Capacity	10,500 Btu/h ⁽¹⁾	25,000 Btu/h ⁽²⁾	29,400 Btu/h ⁽²⁾
Condenser: 95° F, 50% RH	Sensible Cooling Capacity	7,200 Btu/h ⁽¹⁾	18,000 Btu/h ⁽²⁾	20,800 Btu/h ⁽²⁾
Water-cooled model:	Power Consumption	1.23 kW ⁽¹⁾	2.90 kW ⁽²⁾	1.99 kW ⁽²⁾
EWT/LWT: 85° F/ 95° F	Current Consumption	11.2 amps ⁽¹⁾	12.6 amps ⁽²⁾	8.9 amps ⁽²⁾
Evaporator: 72° F, 50% RH	Total Cooling Capacity	9,300 Btu/h ⁽¹⁾	25,000 Btu/h ⁽²⁾	25,200 Btu/h ⁽²⁾
Condenser: 95° F, 50% RH	Sensible Cooling Capacity	7,000 Btu/h ⁽¹⁾	18,900 Btu/h ⁽²⁾	22,000 Btu/h ⁽²⁾
Water-cooled model:	Power Consumption	1.22 kW ⁽¹⁾	3.20 kW ⁽²⁾	2.00 kW ⁽²⁾
EWT/LWT: 85° F/ 95° F	Current Consumption	11 amps ⁽¹⁾	15 amps ⁽²⁾	9 amps ⁽²⁾
Evaporator	Fan Type	Centrifugal	Centrifugal	Centrifugal
	Max. Air Flow - high/low	324/228 CFM ⁽¹⁾	950/800 CFM ⁽²⁾	1060/840 CFM ⁽²⁾
	Max. External Static Pressure	0.16 IWG	0.60 IWG	0.66 IWG
Condenser	Fan Type	Centrifugal	Centrifugal	Water Cooled Condenser
	Max. Air Flow – high/low	700/370 CFM	1,600/1,300 CFM	N/A
	Max. External Static Pressure	0.12 IWG	0.50 IWG	N/A
Compressor	Type	Hermetic Rotary	Hermetic Swing Inverter	Hermetic Swing Inverter
Refrigerant	Type	R-410A	R-410A	R-410A
Dimensions	W x D x H (Without flange)	32 x 20 x 15.2 in	53 x 32 x 20 in	45 x 32 x 20 in
	W x D x H (With flange)	35 x 23 x 16 in	57 x 36 x 20 in	49 x 35 x 20 in
Net Weight/Shipping Weight		123/137 lbs	310/353 lbs	236/271 lbs
Condensate Pump Capacity	Pump Rate	5 gal/h	5 gal/h	5 gal/h
(Internal pump included)	Head	4 ft	4 ft	4 ft
Operating Conditions	Evaporator	65° – 95° F, 50% RH	60°F – 95° F, 50% RH	55°F – 95° F, 50% RH
	Condenser	65° – 113° F	50°F – 113° F	45°F – 115° F (Condenser water)
Max. Duct Length	Cold Duct Hose	20 ft ⁽³⁾	120 ft ⁽³⁾	120 ft ⁽³⁾
	Hot Duct Hose	10 ft ⁽³⁾	90 ft ⁽³⁾	N/A
Max. Sound Level	Under Ceiling Tile with Evaporator Duct	52 dB(A)	55 dB(A)	55 dB(A)



All specifications subject to change without notice. Standard warranty includes 12 months on entire unit and compressor. Visit www.MovinCool.com/reg for details on MovinCool's industry-best free Extended Warranty Program which includes 3 years for portable models and 2 years for ceiling-mount models for both parts and labor on units. All models feature compressor overload relay and fan motor protection. All models also feature compressor short-cycle protection, return air thermostat, automatic restart and accommodate a condensate pump kit. All models are 50 Hertz (Hz) compatible with a slight performance decrease from specifications listed above (except CM25 and CMW30).

(1) Measured with two 6 ft ducts with one 90° bend each, supply grill and return grill with filter (0.16 IWG external static pressure) (ducts not included)
 (2) Measured with two 20 ft ducts with one 90° bend each, supply grill and return grill with filter (0.30 IWG external static pressure) (ducts not included)
 (3) Confirm pressure drop of duct, grills and filter with manufacturer specifications

*Specification information shown with 230V

Testimonials



Nick Best

Director, Cam Op & Editor,
New Creation Video Productions

“For an office, especially on a corner with windows facing the sun and equipment which give off heat, the MovinCool CM25 is definitely the way to go.”



Joe Dotson

Service Account Manager,
Scarborough Mechanical Services, Inc.

“The health-care center has no more shutdowns due to overheating. The CM12 is perfectly designed for this type of application. It has the usual MovinCool quality, it’s easy to install in tight spaces, and it has an affordable price tag.”

Accessories

Condenser air removal: If removing the exhaust is needed, MovinCool makes it easy. The flange can be used to attach a 10-inch (CM12) or 12-inch (CM25) diameter duct for more air exhaust options (duct not included).



#	Part name	CM12	CM25	CMW30
1	Exhaust air flange	481170-0440	481170-0191	N/A

Condenser air intake: The air plenum can be used to prevent negative air pressure in the ceiling space when using the exhaust air-flange and duct to remove exhaust from the ceiling space. Simply attach a 10-inch (CM12) or 14-inch (CM25) diameter duct to the air plenum to bring in air from outside of the ceiling space (duct not included).



#	Part name	CM12	CM25	CMW30
2	Condenser intake air plenum	481769-0221	481769-0240	N/A
2A	Condenser filter kit (not shown)	N/A	484409-0130	N/A

Wall thermostat: Weekday and weekend programmable digital millivolt thermostat.



#	Part name	CM12	CM25	CMW30
3	Wall thermostat	LA484500-3430	Included*	Included*

*Wall Mounted Controller with LCD Display

Auto condensate removal: Condensate pump with 4-foot lift capacity is included with all the units. If more than 4-foot lift capacity is needed, simply use this optional condensate pump kit to boost lift capacity to 17-feet.



#	Part name	CM12	CM25	CMW30
4	Condensate pump kit	N/A	GX484789-0180	GX484789-0190

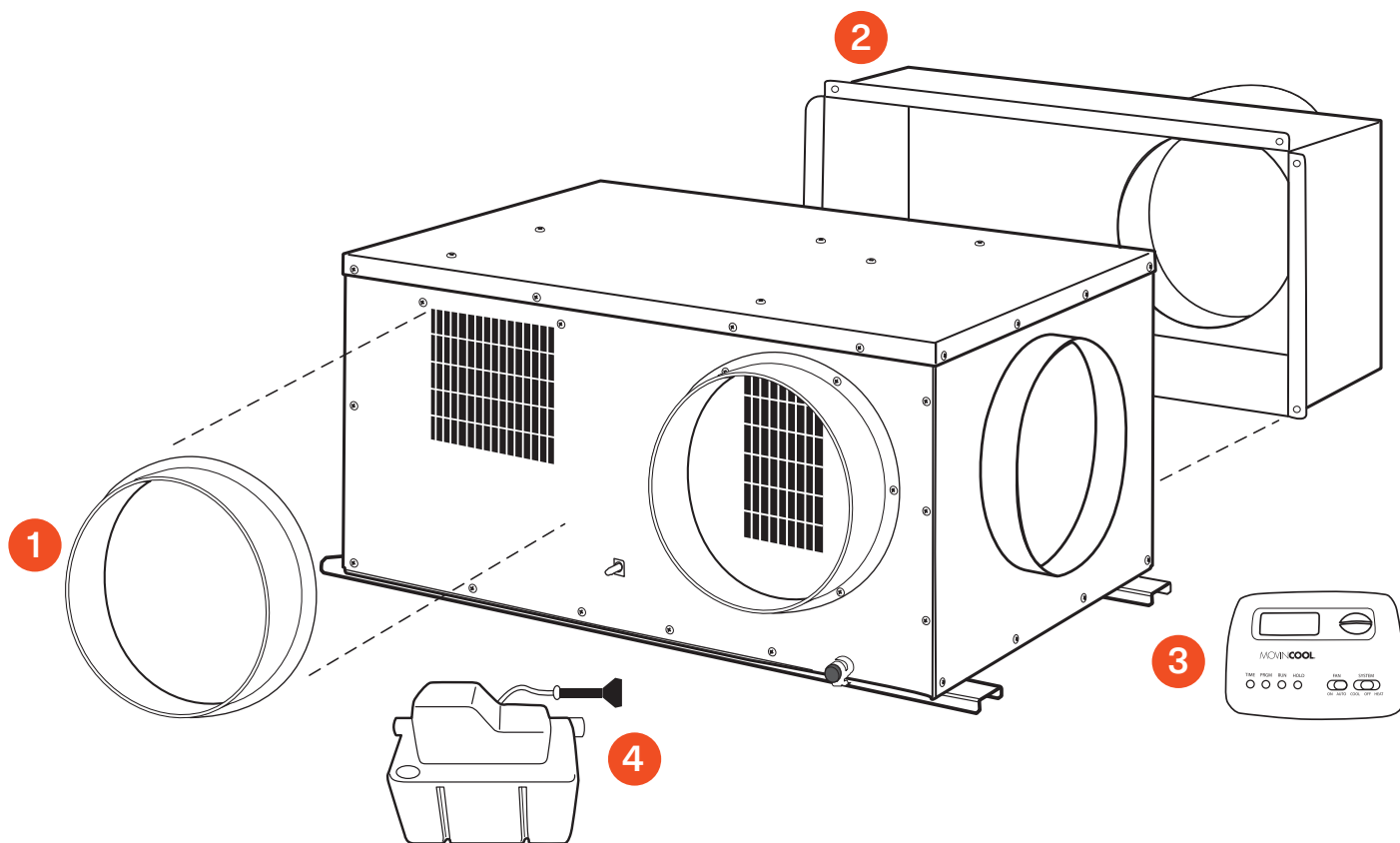

Individual part descriptions for MovinCool CM12, CM25 and CMW30

1	Exhaust air flange	10" or 12" diameter gray metal flange with mounting screws.
2	Condenser intake air plenum	Gray metal plenum with 10" or 14" diameter return air flange. Includes mounting screws.
2A	Condenser filter fit (not shown)	Optional filter kit for condenser air intake for use in heavily dusty environments.
3	Wall thermostat	Weekday & weekend programmable digital millivolt thermostat.
4	Condensate pump kit	230V pump kit to boost lift capacity to 17'. Includes installation hardware.

What our customers are saying...



Eric Rieger

President,
WEBIT Services

"After three failed retail A/C units from a local big box store, I was recommended an Office Pro 12. Its performance and reliability are impressive, and the peace of mind it delivers is priceless. For mission critical needs of server and telecom rooms, you can't beat MovinCool."



Eric Garvin

Manufacturing Engineer,
AUTECS

"I used a Classic Plus 26 and decreased the company's HFMS automotive airflow sensor components' cool-down time from 30 minutes to 96 seconds—a 94% reduction. This improved our production time and reduced handling damage and manpower requirements."



Matt Steding

Division Maintenance Manager,
Allina Hospitals and Clinics

"The flexibility of the CM25's control options made it very easy for us to integrate the unit into our automation system. The EMS lets us build the control logic to remotely monitor, schedule, trend and alarm the points we want, so we have greater control over the unit."



Water cooled



Learn more at trane.com



Trane – by Trane Technologies (NYSE: TT), a global climate innovator – creates comfortable, energy efficient indoor environments through a broad portfolio of heating, ventilating and air conditioning systems and controls, services, parts and supply. For more information, please visit trane.com or tranetechnologies.com.

All trademarks referenced in this document are the trademarks of their respective owners.

© 2020 Trane. All Rights Reserved.

RSP-SLB159-EN
06/16/2020