



Trane® Stealth™ Air-cooled Chillers

150 – 300 tons



An unbeatable combination of high energy efficiency and quiet performance.



An environment offering quiet, dependable cooling can provide many benefits. Inside the building, students can enjoy improved concentration and test scores. Employees can experience higher levels of morale and productivity. And critical applications can function reliably. Outside, quietly operating cooling can help your building to be a good neighbor.

Trane® Stealth™ air-cooled chillers deliver an industry-leading combination of part-load and full-load efficiencies, while offering multiple sound reduction options for noise-sensitive installations. No other air-cooled chiller delivers this kind of efficiency or acoustic performance ... making the Stealth chiller the perfect solution for your building.



The science behind the performance: AdaptiSpeed™ technology

AdaptiSpeed technology delivers highly efficient, reliable performance through the integration of:

- An all-new, direct-drive, specific-speed screw compressor
- Variable-speed, permanent magnet motors, powering the compressor and condenser fans
- The third-generation Adaptive Frequency™ drive, AFD₃

No other air-cooled chiller can bring you the unique efficiency and reliability benefits of a Stealth chiller.

Industry-leading efficiency with no need to compromise

Other air-cooled chillers can deliver good part-load efficiency—but often at the cost of full-load efficiency. Stealth chillers use advanced technologies to deliver an unbeatable combination of efficiency under all operating conditions to lower utility bills and save money.

- **Highest part-load efficiency**—Up to 20 IPLV rating, driving lower overall electrical consumption charges (kWh).
- **Highest full-load efficiency**—Up to 12.1 EER, minimizing the electrical infrastructure required as well as the impact of demand-based utility costs during periods of peak operation.



The increased efficiency and reduced refrigerant charge of a Stealth chiller can help earn multiple LEED® points for your building and qualify for energy rebates and incentives offered by many utility companies across the country.

Innovation at work: Advanced technology driving lower energy consumption

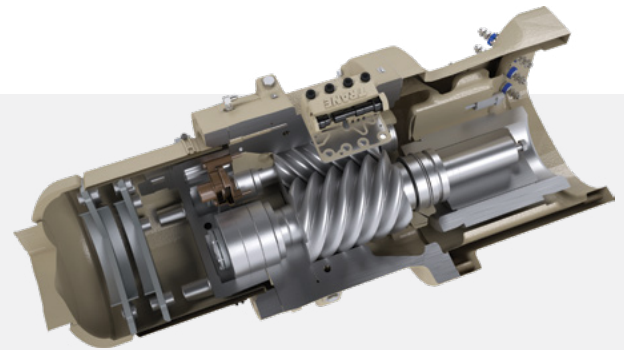

Building on over 40 years of experience designing air-cooled chillers, Trane engineers brought innovation and knowledge to every component used in the next-generation Stealth chiller. The result: reduced energy consumption, improved system flexibility and performance, and the lowest sound levels—all while delivering improved reliability and lower maintenance requirements.

- The Trane third-generation Adaptive Frequency™ drive, AFD₃, offers a **part-load efficiency improvement of more than 40 percent** when compared to previous constant-speed chiller designs. Designed to last the life of the chiller, the AFD₃ is glycol-cooled and contains durable film capacitors.
- **New specific-speed screw compressor technology** delivers peak efficiency under all operating conditions. Compared to the previous compressor, this updated design—which is optimized for variable-speed operation—yields up to a **10 percent improvement in compressor efficiency**.
- The compressor's permanent magnet motor design is up to **4 percent more efficient** than conventional induction motors.
- Permanent magnet, variable-speed motors are also used in the Stealth chiller's condenser fans. These motors offer an additional **efficiency improvement of 2 percent or more at full-load operation and 5 percent or more at part-load operation**.
- New Compact, High-performance, Integrated, Low-charge (CHIL) evaporator technology design optimizes refrigerant flow for improved efficiency and better cooling performance, while using up to 40 percent less refrigerant than traditional flooded designs.

Sound solutions for quiet cooling

HVAC system noise levels can vary widely, and excessive noise can impact the performance, productivity and overall satisfaction of building occupants—as well as occupants of neighboring structures. That is why quiet operation is designed into every Trane® Stealth™ air-cooled chiller, and different levels of InvisiSound™ acoustic reduction treatments are available to give you the flexibility to meet specific application needs.



Variable-speed condenser coil fans help reduce sound output.

The key to every Stealth chiller’s low sound levels is the combination of variable-speed compressors, variable-speed condenser fans and an integrated compressor muffler. Because variable-speed compressors and condenser fans only operate as fast as demand levels require, their overall sound levels are considerably less during off-peak hours than those of constant-speed units. The integrated compressor muffler reduces sound even more—up to 10 dB when compared to the previous compressor designs.

InvisiSound Superior package

For additional sound reduction, our InvisiSound Superior package adds acoustical treatments to key sound-generating components, including the compressor’s suction and discharge lines. This insulating material limits sounds normally emitted from the lines, reducing total sound output levels even further.

InvisiSound technology benefits



Tiers of acoustic reduction treatment options give you the freedom to choose the unit sound level that meets the requirements of your particular application.



Acoustic reduction treatments applied at the factory offer predictable, consistent performance, often saving money when compared to on-site applications.



Noise reduction mode allows you to actively manage unit sound levels to comply with nighttime and weekend noise restrictions.

Sound comparison of 300-ton air-cooled chillers at full load

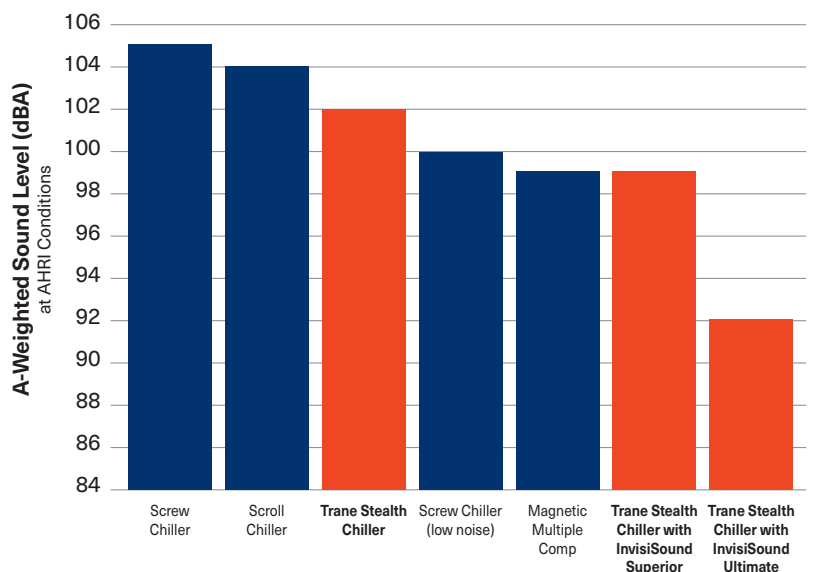

InvisiSound Ultimate package

For installations that require even lower sound levels, the InvisiSound Ultimate package incorporates a patented compressor enclosure and metallic bellows at compressor suction and discharge connection points to absorb vibrations from normal compressor operation. Together, these treatments help produce the lowest published air-cooled chiller sound levels in the industry!

The InvisiSound Ultimate package also includes a user-selectable noise-reduction mode that can be activated to limit the maximum condenser fan speed, achieving even lower sound levels. This feature allows you to actively manage the unit's operation to comply with nighttime and weekend noise restrictions.

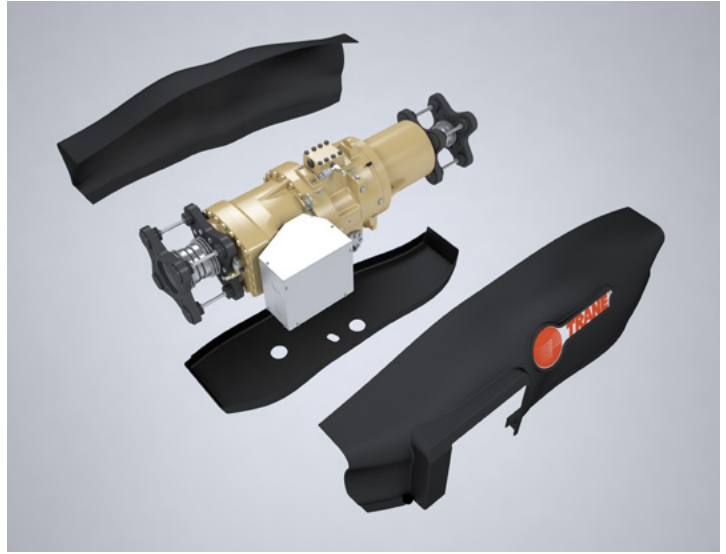

Patented compressor enclosure and metallic bellows absorb vibrations from normal compressor operation.

Ultimate control under all conditions

Trane controls offer performance and efficiency advantages that other controls simply can't match. The Tracer™ UC800 provides the intelligence behind the Stealth chiller and features Adaptive Control™ algorithms: proprietary control strategies that respond to a variety of conditions to maintain efficient chiller plant operation.

- **Easy-to-read 7-inch color touch-screen display**—Shows vital, at-a-glance information about current chiller performance, as well as graphical trending information about chiller performance over time.
- **Industry-leading control algorithms**—Efficiently and effectively direct the chiller's operation, maximizing both performance and reliability by optimizing variable-speed compressors and condenser fans, even in variable primary-flow applications.
- **Adaptive Control**—Keeps the chiller working efficiently in extreme conditions and even under a building automation system failure—so you can count on reliable operation when you need it the most.
- **Trane Intelligent Services enabled**—Offers 24/7 system monitoring and response capabilities.
- **Open-protocol design**—Allows the AdaptiView™ controller to work with any building automation system without the need for gateways, such as BACnet®, Modbus or LonTalk®.

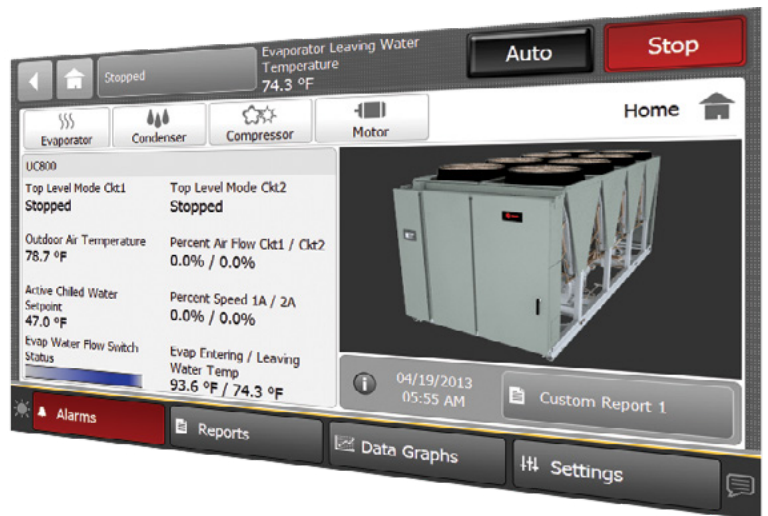

Advanced features to serve advanced applications



Trane® Stealth™ chillers are designed for easy integration with facilities that have specialized requirements.

- **Rapid restart capability**—After a power interruption, Stealth chillers can quickly regain full operational capacity, so mission-critical applications can continue with minimal interruption.
- **Easy compatibility with uninterruptible power systems (UPS)**—The Adaptive Frequency™ drive, AFD₃, offers full compatibility with uninterruptible power systems, so you can count on reliable chiller operation even during power outages.
- **Available harmonic filtration system**—A true 24-pulse design provides the harmonic solution to meet the requirements of IEEE 519, reducing harmonic distortion to less than 5 percent total demand distortion (TDD).

Standard and optional features

Stealth chillers include useful standard features and are available with additional factory-installed options to make system design, installation and start-up faster and easier—saving you time and money. Customize your chiller to meet your unique requirements—without compromise.

- **Standard factory-installed solutions** include a high power factor, temperature-insulating materials and a sound-reducing treatment.
- **Optional factory-installed solutions** include insulating materials with higher thermal properties, additional noise-reduction treatments, a power line harmonics package and CompleteCoat™ condenser fin coating.

A proud new member of the Trane air-cooled chiller product family, supporting your building's needs.

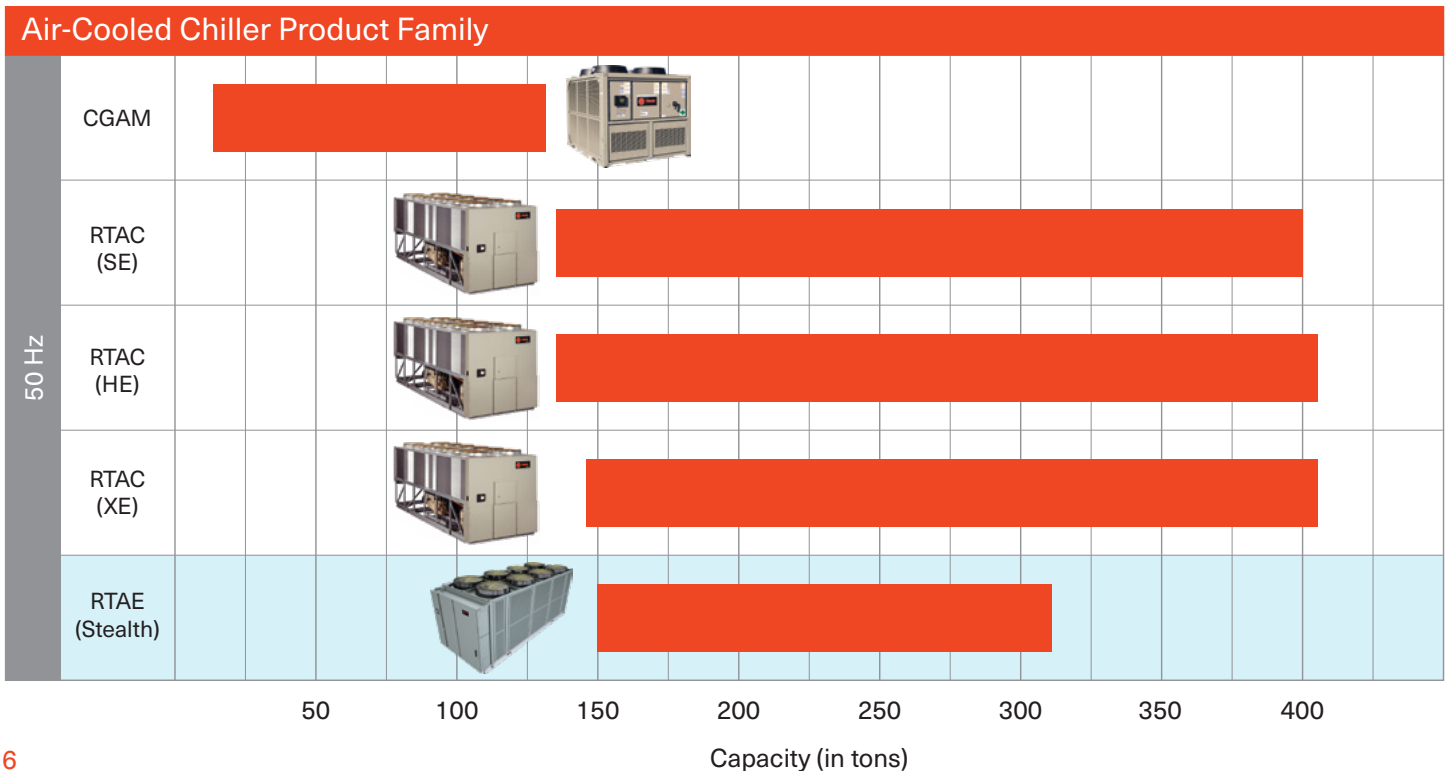

Easier, safer, less-frequent maintenance

Stealth chillers have low maintenance requirements—and are designed to make those maintenance duties easier, safer and less frequent.

- **Maintenance-free, long-life motors**—Stealth chillers' compressor and condenser fans are powered by variable-speed, permanent magnet motors that require no periodic maintenance and are designed for exceptionally long operational life.
- **Transverse “open V” design condenser coils**—This design allows easier cleaning of the condenser coils from the inside out, to keep the coils and the chiller properly functioning.
- **Exclusive third-generation Adaptive Frequency drive**—The Trane® Adaptive Frequency drive, AFD₃, is glycol-cooled and contains durable film capacitors that are engineered to last the life of the chiller.
- **Safety first with “shore power”**—Commissioning the chiller and servicing the AFD₃ drive panel can be performed with only 110 volts of power through a standard extension cord—a design that helps protect technicians from higher line voltages.
- **Trane Intelligent Services enabled**—Stealth chillers can be remotely monitored by Trane Intelligent Services (TIS) 24 hours a day. By continuously monitoring the chiller's operating conditions, TIS can quickly react to changes in performance any time, day or night—addressing potential problems before they become more serious. TIS peace of mind can be added to your Stealth chiller during installation or at any other time during its operational lifespan.

Reliability you can count on

Stealth chillers uphold the legendary Trane reputation for chiller reliability—and can help you experience fewer repairs and less chiller downtime, which can help reduce operational costs.

- The Trane third-generation Adaptive Frequency drive, AFD₃, is designed for the life of the chiller and can effectively handle electrical dips and surges to maintain reliable operation.
- An all-aluminum condenser coil reduces the risk of galvanic corrosion and uses a manifold header design that eliminates U-bends, minimizing the potential for refrigerant leaks. An optional factory-applied CompleteCoat fin protection treatment is available for added corrosion protection.
- A new industrial bearing system and improvements in oil and charge management technology increase compressor life, improve low-ambient start-up capability and increase efficiency over a broad range of operating conditions.



Visit Trane.com/Stealth to learn more
about the Trane[®] Stealth[™] air-cooled chiller
with AdaptiSpeed[™] technology.



Trane – by Trane Technologies (NYSE: TT), a global climate innovator – creates comfortable, energy efficient indoor environments through a broad portfolio of heating, ventilating and air conditioning systems and controls, services, parts and supply. For more information, please visit trane.com or tranetechnologies.com.

All trademarks referenced in this document are the trademarks of their respective owners.

© 2020 Trane. All Rights Reserved.

RLC-SLB028-EN
06/25/2020