



TRANE®

22-1939-1C-EN

Product Data

**Split System (R-410A)
23 Series, Inverter System
9,000 to 36,000 BTU/Hr**

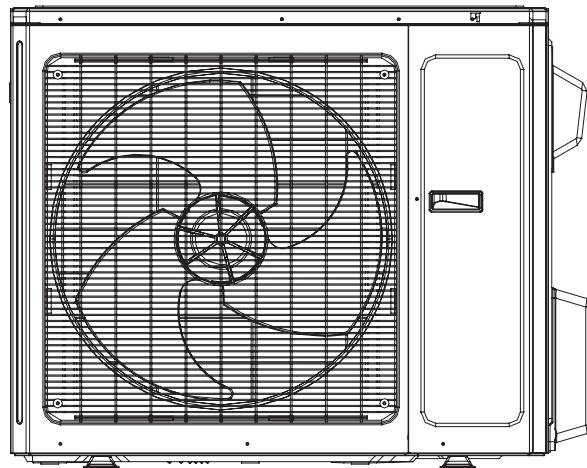
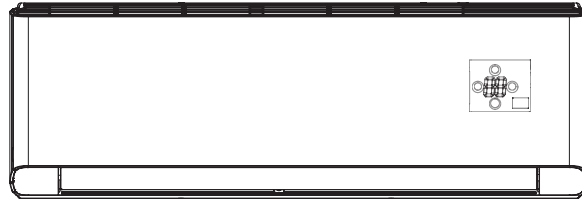

**Single Split
Heat Pump**

**Indoor Unit
4MXW23-A**

**Outdoor Unit
4TXK23-A**

It's Hard to Stop a Trane.

Split System (R-410A, 60Hz) up to 23 Series, Inverter System – 9,000 to 36,000 BTU/Hr

Whatever their specific heating and cooling needs, people trust Trane to provide reliable efficient solutions. Trane Ductless Systems allow you to create a comfortable indoor environment in spaces where adding ductwork might be impractical or too expensive, or not as efficient as a ductless option.

Retrofit a house that doesn't have a ducted system or where the central system is already at capacity. Bring efficient, economical comfort to new room additions. Provide spot heating and cooling that operates independently of the central system. Utilize ductless efficiency for new construction projects where ductless systems make more sense than a traditional ducted system.

Easy to install Trane Ductless Systems offer flexibility in design and provide efficiency and economy with two simple components - an outdoor unit and one or more stylish, low profile, indoor units. All built with Trane's legendary reliability and innovative thinking.

Introducing the New Trane Ductless Family



**4MXW23 High-Efficiency
Indoor Unit**

Quiet Design

Specially designed air vent efficiently reduces operation noise, as low as 29 dB.

Function/Fan Speed

High speed operation quickly reaches desired temperature. Four fan speeds maximize your comfort experience.

Sleep Mode Function

Temperature rises/falls automatically to maintain room comfort and save energy while you sleep.

Blue Fin

Increase durability and ensure continued efficiency with our special anti-corrosion coil treatment. (Standard on all heat pump models.)

Twin Rotary DC Compressor

Provides better balance and higher efficiency.

Compressor Protection

Compressor stops or delays operation when there is mode conflict.

Auto Clean/Triple Filtration

Fan runs when unit is stopped to reduce moisture and inhibit the development of bacteria, and the triple filtration further cleans the air that you breathe.

Anti-Cold Design

To prevent blowing cold air directly to the room, air is pre-heated during heating operation.

Timer

Operate the unit automatically only when you want by setting the timer.

Outdoor Unit

Energy Efficiency

Quickly reach the desired temperature without sacrificing your electricity bills with our higher EER/COP levels.

Robust Grille

Prevent damage without impacting airflow with our strong, hot-dip galvanized steel grille.

Intelligent Defrost

Auto defrosting is implemented if necessary. It improves the system's heating efficiency and helps you save power. (Standard on all heat pump models.)



4TXK23 Outdoor Unit

Contents

Model Nomenclature	4
<hr/>	
Optional Equipment	5
<hr/>	
General Data – IP	6–8
<hr/>	
General Data – SI	9–11
<hr/>	
Performance Data	12–17
<hr/>	
Mechanical Specifications	18
<hr/>	

OUTDOOR UNIT MODEL NOMENCLATURE

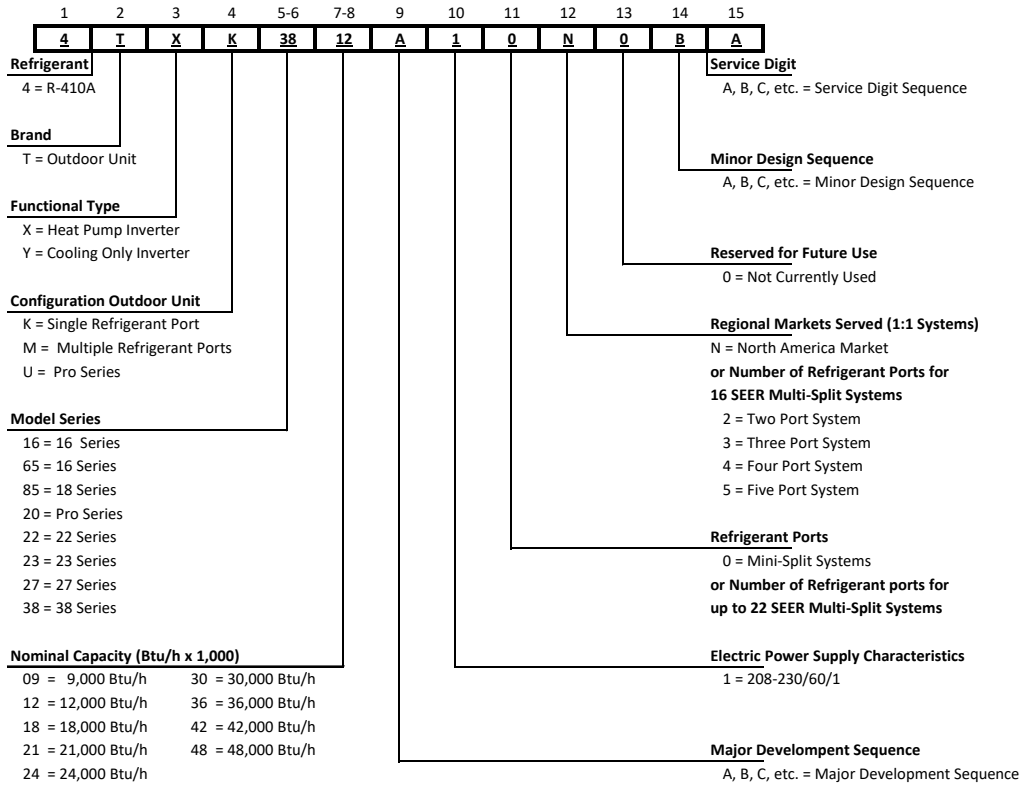

INDOOR UNIT MODEL NOMENCLATURE

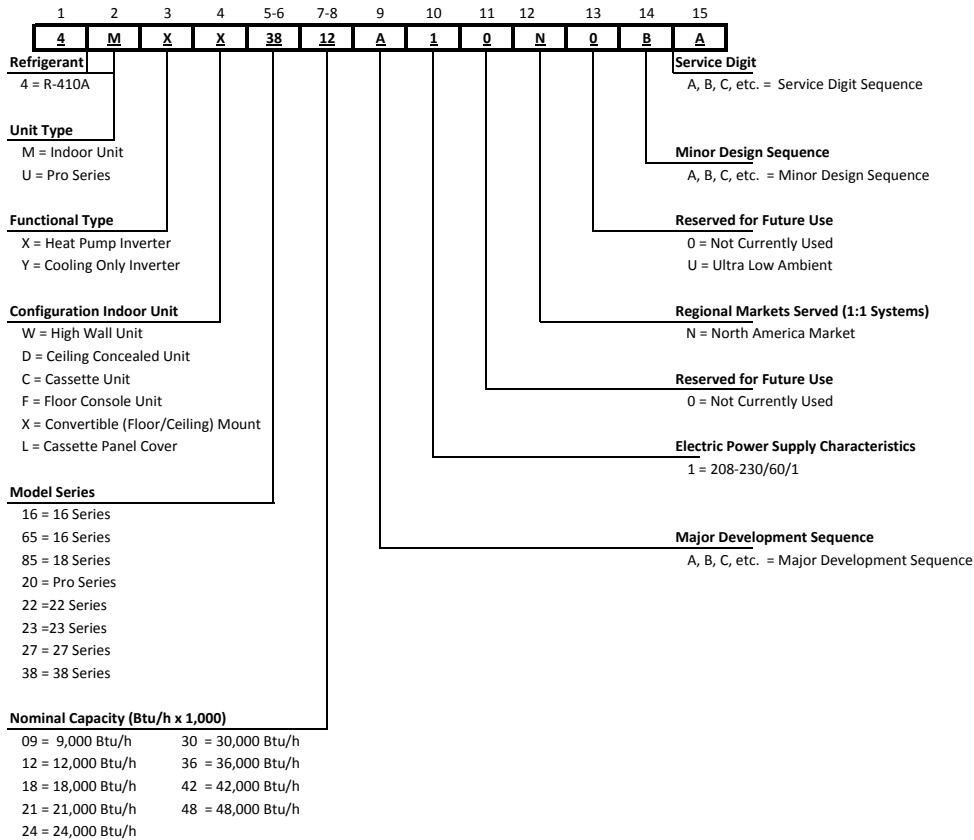

Optional Equipment

Optional outdoor unit accessories

Model Number	Description	4TXK23 Mini-split HP 23 Series
TAYREFLN050	Lineset Kit 1/4x3/8 - 25'	✓
TAYREFLN055	Lineset Kit 1/4x3/8 - 35'	✓
TAYREFLN060	Lineset Kit 1/4x3/8 - 50'	✓
TAYREFLN560	Lineset Kit 1/4x1/2 - 25'	✓
TAYREFLN565	Lineset Kit 1/4x1/2 - 35'	✓
TAYREFLN570	Lineset Kit 1/4x1/2 - 50'	✓
TAYREFLN575	Lineset Kit 1/4x1/2 - 100'	✓
TAYREFLN155	Lineset Kit 1/4x5/8 - 25'	✓
TAYREFLN160	Lineset Kit 1/4x5/8 - 35'	✓
TAYREFLN165	Lineset Kit 1/4x5/8 - 50'	✓
TAYREFLN170	Lineset Kit 1/4x5/8 - 100'	✓

Optional indoor unit accessories

Model Number	Description	4MXW23 Mini-split Indoor 23 Series
BAYFTHW02P2A	Active Carbon & Catechin filter for 23 Series units	✓
AREMOTE2AHANDAA	Wireless Controller	✓
TREWIRE1BHANDAA	Wired Controller	✓
AREPROG1AHANDAA	Programmable Controller	✓

Application Area/Air Throw for High Wall			
Model	Application Area	Cooling Mode	Heating Mode
4MXW2309	129-194 sf. (12-18 m ²)	29.5 (9)	23 (7)
4MXW2312	172-258 sf. (16-24 m ²)		
4MXW2318	248-366 sf. (23-34 m ²)	31.2 (9.5)	21.6 (6.5)
4MXW2324	291-452 sf. (27-42 m ²)		19.7 (6)
4MXW2330	377-560 sf. (35-52 m ²)		30.8 (9.4)
4MXW2336	495-753 sf. (46-70 m ²)		
			Unit: ft. (m)

General Data – IP

MODEL – Heat Pump Only	4MXW2309A10N / 4TXK2309A10N		4MXW2312A10N / 4TXK2312A10N	
	Cooling	Heating	Cooling	Heating
RATED Volts/PH	208 / 230 / 1		208 / 230 / 1	
Frequency (Hz)	60Hz		60Hz	
Rated Cooling / Heating Capacity (Btu/h):	9000	11000	12000	13000
Minimum Cooling Capacity (@95°F) (Btu/h): ②	3100	-	3100	-
Maximum Cooling Capacity (@95°F) (Btu/h): ②	9600	-	13000	-
Minimum Heating Capacity (@47°F) (Btu/h): ②	-	1900	-	2400
Maximum Heating Capacity (@47°F) (Btu/h): ②	-	12000	-	14000
Rated Heating Capacity (@17°F) (Btu/h): ②	-	6800	-	7100
Total Capacity (W) (High/Standard/Low):	2814/2638/908	3517/3224/560	3810/3517/908	4103/3810/703
Nominal Power Input (W)	630	1020	960	1100
Nominal Input Current (A)	2.8	3.5	4.5	5.5
SEER / HSPF	23.0	10.5	22.0	11.0
EER / COP (Btu/h)/W	14.0	10.8	12.5	11.8
Air Flow Volume (CFM) (H//M/L/QUIET)	375/275/225/175		400/275/225/175	
Dehumidifying Volume (pt./h)	1.7		3.0	

Indoor Unit	4MXW2309A10N		4MXW2312A10N	
Fan Motor Speed (r/min) (H//M/L/QUIET)	1350/1200/1050/750	1300/1150/1000/900	1400/1200/1050/800	1400/1200/1000/900
Fan Motor RLA(A)	0.09		0.09	
Evaporator	Aluminum Fin-Copper Tube		Aluminum Fin-Copper Tube	
Pipe Diameter (inch)	0.28		0.28	
Rows - Fin Gap (inch)	2 - 0.06		2.0 - 0.06	
Coil length (L) x depth (D) x coil width (W) (inch)	25 × 0.9 × 12.1		25 × 0.9 × 12.1	
Output of Swing Motor (W)	1.5		1.5	
Fuse (A)	3.15		3.15	
Sound PRESSURE Level dB (A)(H//M/L/QUIET) ①	43/39/35/29		45/39/35/29	
Uncrated Dimension (W/H/D) (inch)	33.3 × 11.4 × 8.2		33.3 × 11.4 × 8.2	
Crated Dimension of Package (L/W/H) (inch)	36.3 × 11.1 × 14.9		36.3 × 11.1 × 14.9	
Net Weight /Gross Weight (lbs)	22.1 / 26.5		22 / 26.5	

Outdoor Unit	4TXK2309A10N		4TXK2312A10N	
Compressor Type	Swing		Swing	
Compressor Oil Type	DAPHNE FVC50K (PVE Oil)		DAPHNE FVC50K (PVE Oil)	
Compressor RLA(A)	4.0		4.0	
Compressor Power Input(W)	845		845	
Throttling Method	EEV		EEV	
Working Temp Range (°F)	0 ~ 115	-4 ~ 75	0 ~ 115	-4 ~ 75
Condenser	Aluminum Fin-Copper Tube		Aluminum Fin-Copper Tube	
Pipe Diameter (inch)	0.38		0.38	
Rows - Fin Gap (inch)	2 - 0.06		2 - 0.06	
Coil length (L) x depth (D) x coil width (W) (inch)	29.4 × 1.7 × 20		29.4 × 1.7 × 22	
Fan Motor Speed (rpm)	900		900	
Output of Fan Motor (W)	30		30	
Fan Motor RLA (A)	0.36		0.36	
Air Flow Volume of Outdoor Unit (CFM)	623		693	
Fan Diameter (inch)	15.8		15.8	
Defrosting Method	Automatic Defrosting		Automatic Defrosting	
Sound PRESSURE Level dB (A)①	53		54	
Uncrated Dimension (W/H/D) (inch)	33.4 × 21.3 × 12.6		33.4 × 23.3 × 12.6	
Crated Dimension of Package (L/W/H) (inch)	34.7 × 14.3 × 23.4		34.7 × 14.3 × 25.4	
Net Weight /Gross Weight (lbs)	78.3 / 83.8		85.6 / 92.6	
Refrigerant Charge (oz)	46		48	
MCA	9		9	
MOP	15		15	

Connection Pipe		
Gas additional charge(oz/ft)	0.22	0.22
Outer Diameter Liquid Pipe (inch)	1/4	1/4
Outer Diameter Gas Pipe (inch)	3/8	1/2
Max Height Distance (ft)	55	55
Max Length Distance (ft)	100	100

① Sound PRESSURE Level @ 3.3 ft. dB(A)
 ② Capacities based on fixed compressor speed AHRI validation testing

General Data – IP

MODEL – Heat Pump Only	4MXW2318A10N / 4TXK2318A10N		4MXW2324A10N / 4TXK2324A10N	
	Cooling	Heating	Cooling	Heating
RATED Volts/PH	208 / 230 / 1		208 / 230 / 1	
Frequency (Hz)	60Hz		60Hz	
Rated Cooling / Heating Capacity (Btu/h):	18000	19800	22000	23000
Minimum Cooling Capacity (@95°F) (Btu/h): ②	6800	-	6800	-
Maximum Cooling Capacity (@95°F) (Btu/h): ②	20000	-	27200	-
Minimum Heating Capacity (@47°F) (Btu/h): ②	-	7300	-	6800
Maximum Heating Capacity (@47°F) (Btu/h): ②	-	23500	-	30600
Rated Heating Capacity (@17°F) (Btu/h): ②	-	12400	-	14600
Total Capacity (W) (High/Standard/Low):	5860/5275/2000	6890/5800/2150	8000/6448/2000	9000/6741/2000
Nominal Power Input (W)	1435	1730	1760	2000
Nominal Input Current (A)	6.4	7.7	8.05	8.35
SEER / HSPF	20.0	10.7	20.0	10.2
EER / COP (Btu/h)/W	12.5	11.5	12.5	11.5
Air Flow Volume (CFM) (H//M/L/QUIET)	550/475/400/335		700/650/575/525	
Dehumidifying Volume (pt./h)	3.8		4.2	

Indoor Unit	4MXW2318A10N		4MXW2324A10N	
Fan Motor Speed (r/min) (H//M/L/QUIET)	1400/1200/1050/800	1400/1200/1100/900	1300/1100/900/850	1300/1100/1000/900
Fan Motor RLA(A)	0.24		0.38	
Evaporator	Aluminum Fin-Copper Tube		Aluminum Fin-Copper Tube	
Pipe Diameter (inch)	0.28		0.28	
Rows - Fin Gap (inch)	2 - 0.06		2 - 0.06	
Coil length (L) x depth (D) x coil width (W) (inch)	28.1 x 1 x 12		33.25 x 1 x 13.5	
Output of Swing Motor (W)	2.5		2.5	
Fuse (A)	3.15		3.15	
Sound PRESSURE Level dB (A)(H//M/L/QUIET) ①	47/43/40/39		48/44/40/36	
Uncrated Dimension (W/H/D) (inch)	38.2 x 11.8 x 8.8		42.4 x 12.8 x 9.7	
Crated Dimension of Package (L/W/H) (inch)	41 x 15.1 x 12.6		45.2 x 16.3 x 13.8	
Net Weight /Gross Weight (lbs)	27.6 / 34.2		34.2 / 41.9	

Outdoor Unit	4TXK2318A10N		4TXK2324A10N	
Compressor Type	Rotary		Rotary	
Compressor Oil Type	RB68EP (POE Oil)		RB68EP (POE Oil)	
Compressor RLA(A)	12.1		11.5	
Compressor Power Input(W)	1440		2550	
Throttling Method	EEV		EEV	
Working Temp Range (°F)	0 ~ 115	-4 ~ 75	0 ~ 115	-4 ~ 75
Condenser	Aluminum Fin-Copper Tube		Aluminum Fin-Copper Tube	
Pipe Diameter (inch)	0.28		0.28	
Rows - Fin Gap (inch)	2 - 0.06		2 - 0.06	
Coil length (L) x depth (D) x coil width (W) (inch)	36.8 x 1.5 x 26		37.5 x 1.5 x 29.4	
Fan Motor Speed (rpm)	800		820	
Output of Fan Motor (W)	60		92	
Fan Motor RLA (A)	0.49		0.65	
Air Flow Volume of Outdoor Unit (CFM)	1108		1386	
Fan Diameter (inch)	21.7		21.7	
Defrosting Method	Automatic Defrosting		Automatic Defrosting	
Sound PRESSURE Level dB (A)①	55		59	
Uncrated Dimension (W/H/D) (inch)	37.6 x 27.6 x 15.6		38.6 x 31.1 x 16.8	
Crated Dimension of Package (L/W/H) (inch)	40.5 x 18.0 x 29.5		42.6 x 19.2 x 33.7	
Net Weight /Gross Weight (lbs)	105.8 / 115.8		142.2 / 153.2	
Refrigerant Charge (oz)	56		78	
MCA	16		20	
MOP	25		30	

Connection Pipe		
Gas additional charge(oz/ft)	0.2	0.5
Outer Diameter Liquid Pipe (inch)	1/4	1/4
Outer Diameter Gas Pipe (inch)	5/8	5/8
Max Height Distance (ft)	55	55
Max Length Distance (ft)	130	130

① Sound PRESSURE Level @ 3.3 ft. dB(A)

② Capacities based on fixed compressor speed AHRI validation testing

General Data – IP

MODEL – Heat Pump Only	4MXW2330A10N / 4TXK2330A10N		4MXW2336A10N / 4TXK2336A10N	
	Cooling	Heating	Cooling	Heating
RATED Volts/PH	208 / 230 / 1		208 / 230 / 1	
Frequency (Hz)	60Hz		60Hz	
Rated Cooling / Heating Capacity (Btu/h):	28000	28400	33600	34600
Minimum Cooling Capacity (@95°F) (Btu/h): ②	9400	-	7400	-
Maximum Cooling Capacity (@95°F) (Btu/h): ②	30000	-	36000	-
Minimum Heating Capacity (@47°F) (Btu/h): ②	-	9800	-	14800
Maximum Heating Capacity (@47°F) (Btu/h): ②	-	32800	-	36000
Rated Heating Capacity (@17°F) (Btu/h): ②	-	19200	-	20200
Total Capacity (W) (High/Standard/Low):	8800/8200/2780	9670/8320/2930	10550/9850/2170	10550/10140/4390
Nominal Power Input (W)	2700	2800	4100	3800
Nominal Input Current (A)	11.5	12.0	17.0	16.5
SEER / HSPF	18.0	9.0	18.0	9.2
EER / COP (Btu/h)/W	10.35	10.14	8.2	9.1
Air Flow Volume (CFM) (H//M/L/QUIET)	700/625/525/400		725/650/525/400	
Dehumidifying Volume (pt./h)	6.3		7.4	

Indoor Unit	4MXW2330A10N		4MXW2336A10N	
Fan Motor Speed (r/min) (H//M/L/QUIET)	1350/1150/950/850	1350/1200/1000/800	1400/1250/1000/800	1400/1250/1050/850
Fan Motor RLA(A)	0.4		0.4	
Evaporator	Aluminum Fin-Copper Tube		Aluminum Fin-Copper Tube	
Pipe Diameter (inch)	0.28		0.28	
Rows - Fin Gap (inch)	2 - 0.06		2 - 0.06	
Coil length (L) x depth (D) x coil width (W) (inch)	42.3 × 1 × 15		42.3 × 1 × 15	
Output of Swing Motor (W)	1.5		1.5	
Fuse (A)	3.15		3.15	
Sound PRESSURE Level dB (A)(H//M/L/QUIET) ①	51/45/41/37		54/49/44/37	
Uncrated Dimension (W/H/D) (inch)	53.2 × 12.8 × 10.0		53.2 × 12.8 × 10	
Crated Dimension of Package (L/W/H) (inch)	56.7 × 16.6 × 14.5		56.7 × 16.6 × 14.5	
Net Weight /Gross Weight (lbs)	41.9 / 51.8		41.9 / 51.8	

Outdoor Unit	4TXK2330A10N		4TXK2336A10N	
Compressor Type	Rotary		Rotary	
Compressor Oil Type	RB68EP (POE Oil)		FV50S (PVE Oil)	
Compressor RLA(A)	13.45		17.5	
Compressor Power Input(W)	2450		3010	
Throttling Method	EEV		EEV	
Working Temp Range (°F)	0 ~ 115	-4 ~ 75	0 ~ 115	-4 ~ 75
Condenser	Aluminum Fin-Copper Tube		Aluminum Fin-Copper Tube	
Pipe Diameter (inch)	0.31		0.38	
Rows - Fin Gap (inch)	2 - 0.06		2 - 0.06	
Coil length (L) x depth (D) x coil width (W) (inch)	37.5 × 1.5 × 29.4		37 × 1.75 × 30	
Fan Motor Speed (rpm)	795		890	
Output of Fan Motor (W)	120		170	
Fan Motor RLA (A)	0.45		0.73	
Air Flow Volume of Outdoor Unit (CFM)	1386		1524	
Fan Diameter (inch)	21.7		21.7	
Defrosting Method	Automatic Defrosting		Automatic Defrosting	
Sound PRESSURE Level dB (A)①	62		65	
Uncrated Dimension (W/H/D) (inch)	38.6 × 31.1 × 16.8		38.6 × 31.1 × 16.8	
Crated Dimension of Package (L/W/H) (inch)	42.7 × 19.2 × 33.7		42.6 × 19.2 × 33.7	
Net Weight /Gross Weight (lbs)	154.4 / 165.4		161 / 172	
Refrigerant Charge (oz)	85		92	
MCA	20		24	
MOP	30		40	

Connection Pipe		
Gas additional charge(oz/ft)	0.5	0.5
Outer Diameter Liquid Pipe (inch)	1/4	1/4
Outer Diameter Gas Pipe (inch)	5/8	5/8
Max Height Distance (ft)	55	55
Max Length Distance (ft)	130	130

① Sound PRESSURE Level @ 3.3 ft. dB(A)
 ② Capacities based on fixed compressor speed AHRI validation testing

General Data – SI

MODEL – Heat Pump Only	4MXW2309A10N / 4TXK2309A10N		4MXW2312A10N / 4TXK2312A10N	
	Cooling	Heating	Cooling	Heating
RATED Volts/PH	208 / 230 / 1		208 / 230 / 1	
Frequency (Hz)	60Hz		60Hz	
Rated Cooling / Heating Capacity (Btu/h):	9000	11000	12000	13000
Minimum Cooling Capacity (@35°C) (Btu/h): ②	3100	-	3100	-
Maximum Cooling Capacity (@35°C) (Btu/h): ②	9600	-	13000	-
Minimum Heating Capacity (@8.3°C) (Btu/h): ②	-	1900	-	2400
Maximum Heating Capacity (@8.3°C) (Btu/h): ②	-	12000	-	14000
Rated Heating Capacity (@-8.3°C) (Btu/h): ②	-	6800	-	7100
Total Capacity (W) (High/Standard/Low):	2814/2638/908	3517/3224/560	3810/3517/908	4103/3810/703
Nominal Power Input (W)	630	1020	960	1100
Nominal Input Current (A)	2.8	3.5	4.5	5.5
SEER / HSPF	23.0	10.5	22.0	11.0
EER / COP (Btu/h)/W	14.0	10.8	12.5	11.8
Air Flow Volume (m³/h) (H//M/L/QUIET)	640/490/410/290		680/490/410/290	
Dehumidifying Volume (L/h)	0.80		1.4	

Indoor Unit	4MXW2309A10N		4MXW2312A10N	
	Fan Motor Speed (r/min) (H//M/L/QUIET)	1350/1200/1050/750	1300/1150/1000/900	1400/1200/1050/800
Fan Motor RLA(A)	0.09		0.09	
Evaporator	Aluminum Fin-Copper Tube		Aluminum Fin-Copper Tube	
Pipe Diameter (mm)	φ 7		φ 7	
Rows - Fin Gap (mm)	2 - 1.4		2 - 1.4	
Coil length (L) x depth (D) x coil width (W) (mm)	635×22.8×306.3		635×22.8×306.3	
Output of Swing Motor (W)	1.5		1.5	
Fuse (A)	3.15		3.15	
Sound PRESSURE Level dB (A)(H//M/L/QUIET) ①	43/39/35/29		45/39/35/29	
Uncrated Dimension (W/H/D) (mm)	845×289×209		845×289×209	
Crated Dimension of Package (L/W/H) (mm)	921×281×379		921×281×379	
Net Weight /Gross Weight (kg)	10 / 12		10 / 12	

Outdoor Unit	4TXK2309A10N		4TXK2312A10N	
	Compressor Type	Swing		Swing
Compressor Oil Type	DAPHNE FVC50K (PVE Oil)		DAPHNE FVC50K (PVE Oil)	
Compressor RLA(A)	4.0		4.0	
Compressor Power Input(W)	845		845	
Throttling Method	EEV		EEV	
Working Temp Range (°C)	-18 ~ 46	-20 ~ 24	-18 ~ 46	-20 ~ 24
Condenser	Aluminum Fin-Copper Tube		Aluminum Fin-Copper Tube	
Pipe Diameter (mm)	φ 9.5		φ 9.5	
Rows - Fin Gap (mm)	2 - 1.4		3 - 1.4	
Coil length (L) x depth (D) x coil width (W) (mm)	747×44×508		747×44×559	
Fan Motor Speed (rpm)	900		900	
Output of Fan Motor (W)	30		30	
Fan Motor RLA (A)	0.36		0.36	
Air Flow Volume of Outdoor Unit (m³h)	1059		1177	
Fan Diameter (mm)	400		400	
Defrosting Method	Automatic Defrosting		Automatic Defrosting	
Sound PRESSURE Level dB (A)①	53		54	
Uncrated Dimension (W/H/D) (mm)	848×540×320		848×592×320	
Crated Dimension of Package (L/W/H) (mm)	881×363×595		881×363×645	
Net Weight /Gross Weight (kg)	35.5 / 38		39 / 42	
Refrigerant Charge (kg)	1.3		1.35	
MCA	9		9	
MOP	15		15	

Connection Pipe		
Gas additional charge(g/m)	20	20
Outer Diameter Liquid Pipe (mm)	φ 6	φ 6
Outer Diameter Gas Pipe (mm)	φ 9.5	φ 12
Max Height Distance (m)	17	17
Max Length Distance (m)	30	30

① Sound PRESSURE Level @ 1m dB(A)

② Capacities based on fixed compressor speed AHRI validation testing

General Data – SI

MODEL – Heat Pump Only	4MXW2318A10N / 4TXK2318A10N		4MXW2324A10N / 4TXK2324A10N	
	Cooling	Heating	Cooling	Heating
RATED Volts/PH	208 / 230 / 1		208 / 230 / 1	
Frequency (Hz)	60Hz		60Hz	
Rated Cooling / Heating Capacity (Btu/h):	18000	19800	22000	23000
Minimum Cooling Capacity (@35°C) (Btu/h): ②	6800	-	6800	-
Maximum Cooling Capacity (@35°C) (Btu/h): ②	20000	-	27200	-
Minimum Heating Capacity (@8.3°C) (Btu/h): ②	-	7300	-	6800
Maximum Heating Capacity (@8.3°C) (Btu/h): ②	-	23500	-	30600
Rated Heating Capacity (@-8.3°C) (Btu/h): ②	-	12400	-	14600
Total Capacity (W) (High/Standard/Low):	5860/5275/2000	6890/5800/2150	8000/6448/2000	9000/6741/2000
Nominal Power Input (W)	1435	1730	1760	2000
Nominal Input Current (A)	6.4	7.7	8.05	8.35
SEER / HSPF	20.0	10.7	20.0	10.2
EER / COP (Btu/h)/W	12.5	11.5	12.5	11.5
Air Flow Volume (m³/h) (H//M/L/QUIET)	950/830/700/570		1200/1100/ /1000/ /900	
Dehumidifying Volume (L/h)	1.8		2.0	

Indoor Unit	4MXW2318A10N		4MXW2324A10N	
	Fan Motor Speed (r/min) (H//M/L/QUIET)	1400/1200/1050/800	1400/1200/1100/900	1300/1100/900/850
Fan Motor RLA(A)	0.24		0.38	
Evaporator	Aluminum Fin-Copper Tube		Aluminum Fin-Copper Tube	
Pipe Diameter (mm)	φ 7		φ 7	
Rows - Fin Gap (mm)	2 - 1.4		2 - 1.5	
Coil length (L) x depth (D) x coil width (W) (mm)	715x25.4x304.8		845x25.4x342.9	
Output of Swing Motor (W)	2.5		2.5	
Fuse (A)	3.15		3.15	
Sound PRESSURE Level dB (A)(H//M/L/QUIET) ①	47/43/40/39		48/44/40/36	
Uncrated Dimension (W/H/D) (mm)	970x300x224		1078x325x246	
Crated Dimension of Package (L/W/H) (mm)	1041x383x320		1148x413x350	
Net Weight /Gross Weight (kg)	12.5 / 15.5		15.5 / 19	

Outdoor Unit	4TXK2318A10N		4TXK2324A10N	
	Compressor Type	Rotary		Rotary
Compressor Oil Type	RB68EP (POE Oil)		RB68EP (POE Oil)	
Compressor RLA(A)	12.1		11.5	
Compressor Power Input(W)	1440		2550	
Throttling Method	EEV		EEV	
Working Temp Range (°C)	-18 ~ 46	-20 ~ 24	-18 ~ 46	-20 ~ 24
Condenser	Aluminum Fin-copper Tube		Aluminum Fin-Copper Tube	
Pipe Diameter (mm)	φ 7		φ 7	
Rows - Fin Gap (mm)	3 - 1.4		2 - 1.4	
Coil length (L) x depth (D) x coil width (W) (mm)	935x38.1x660		952x38.1x748	
Fan Motor Speed (rpm)	800		820	
Output of Fan Motor (W)	60		92	
Fan Motor RLA (A)	0.49		0.65	
Air Flow Volume of Outdoor Unit (m³/h)	1883		2354	
Fan Diameter (mm)	550		550	
Defrosting Method	Automatic Defrosting		Automatic Defrosting	
Sound PRESSURE Level dB (A)①	55		59	
Uncrated Dimension (W/H/D) (mm)	955x700x396		980x790x427	
Crated Dimension of Package (L/W/H) (mm)	1029x458x750		1083x488x855	
Net Weight /Gross Weight (kg)	48 / 52.5		64.5 / 69.5	
Refrigerant Charge (kg)	1.6		2.2	
MCA	16		20	
MOP	25		30	

Connection Pipe		
Gas additional charge(g/m)	15	50
Outer Diameter Liquid Pipe (mm)	φ 6	φ 6
Outer Diameter Gas Pipe (mm)	φ 16	φ 16
Max Height Distance (m)	17	17
Max Length Distance (m)	40	40

1 Sound PRESSURE Level @ 1m dB(A)

2 Capacities based on fixed compressor speed AHRI validation testing

General Data – SI

MODEL – Heat Pump Only	4MXW2330A10N / 4TXK2330A10N		4MXW2336A10N / 4TXK2336A10N	
	Cooling	Heating	Cooling	Heating
RATED Volts/PH	208 / 230 / 1		208 / 230 / 1	
Frequency (Hz)	60Hz		60Hz	
Rated Cooling / Heating Capacity (Btu/h):	28000	28400	33600	34600
Minimum Cooling Capacity (@35°C) (Btu/h): ②	9400	-	7400	-
Maximum Cooling Capacity (@35°C) (Btu/h): ②	30000	-	36000	-
Minimum Heating Capacity (@8.3°C) (Btu/h): ②	-	9800	-	14800
Maximum Heating Capacity (@8.3°C) (Btu/h): ②	-	32800	-	36000
Rated Heating Capacity (@-8.3°C) (Btu/h): ②	-	19200	-	20200
Total Capacity (W) (High/Standard/Low):	8800/8200/2780	9670/8320/2930	10550/9850/2170	10550/10140/4390
Nominal Power Input (W)	2700	2800	4100	3800
Nominal Input Current (A)	11.5	12.0	17.0	16.5
SEER / HSPF	18.0	9.0	18.0	9.2
EER / COP (Btu/h)/W	10.35	10.14	8.2	9.1
Air Flow Volume (m ³ /h) (H//M/L/QUIET)	1200/1050/900/700		1250/1100/900/700	
Dehumidifying Volume (L/h)	3.0		3.5	

Indoor Unit	4MXW2330A10N		4MXW2336A10N	
Fan Motor Speed (r/min) (H//M/L/QUIET)	1350/1150/950/850	1350/1200/1000/800	1400/1250/1000/800	1400/1250/1050/850
Fan Motor RLA(A)	0.4		0.4	
Evaporator	Aluminum Fin-Copper Tube		Aluminum Fin-Copper Tube	
Pipe Diameter (mm)	φ 7		φ 7	
Rows - Fin Gap (mm)	2 - 1.4		2 - 1.4	
Coil length (L) x depth (D) x coil width (W) (mm)	1074x25.4x381		1074x25.4x381	
Output of Swing Motor (W)	1.5		1.5	
Fuse (A)	3.15		3.15	
Sound PRESSURE Level dB (A)(H//M/L/QUIET) ①	51/45/41/37		54/49/44/37	
Uncrated Dimension (W/H/D) (mm)	1350x326x253		1350x326x253	
Crated Dimension of Package (L/W/H) (mm)	1441x421x367		1441x421x367	
Net Weight /Gross Weight (kg)	19 / 23.5		19 / 23.5	

Outdoor Unit	4TXK2330A10N		4TXK2336A10N	
Compressor Type	Rotary		Rotary	
Compressor Oil Type	RB68EP (POE Oil)		FV50S (PVE Oil)	
Compressor RLA(A)	13.45		17.5	
Compressor Power Input(W)	2450		3010	
Throttling Method	EEV		EEV	
Working Temp Range (°C)	-18 ~ 46	-20 ~ 24	-18 ~ 46	-20 ~ 24
Condenser	Aluminum Fin-copper Tube		Aluminum Fin-copper Tube	
Pipe Diameter (mm)	φ 7.9		φ 9.5	
Rows - Fin Gap (mm)	2 - 1.4		2 - 1.4	
Coil length (L) x depth (D) x coil width (W) (mm)	953.5x38.1x748		940.5x44x762	
Fan Motor Speed (rpm)	795		890	
Output of Fan Motor (W)	120		170	
Fan Motor RLA (A)	0.45		0.73	
Air Flow Volume of Outdoor Unit (m ³ /h)	2354		2590	
Fan Diameter (mm)	550		550	
Defrosting Method	Automatic Defrosting		Automatic Defrosting	
Sound PRESSURE Level dB (A)①	62		65	
Uncrated Dimension (W/H/D) (mm)	980x790x427		980x790x427	
Crated Dimension of Package (L/W/H) (mm)	1083x488x855		1083x488x855	
Net Weight /Gross Weight (kg)	70 / 75		73 / 78	
Refrigerant Charge (kg)	2.4		2.6	
MCA	20		24	
MOP	30		40	

Connection Pipe		
Gas additional charge(g/m)	50	50
Outer Diameter Liquid Pipe (mm)	φ 6	φ 6
Outer Diameter Gas Pipe (mm)	φ 16	φ 16
Max Height Distance (m)	17	17
Max Length Distance (m)	40	40

① Sound PRESSURE Level @ 1m dB(A)

② Capacities based on fixed compressor speed AHRI validation testing

Performance Data

4TXK2309A10N/4MXW2309A10N - Cooling Mode Performance Data

Outdoor Ambient Air Temperature (°F)	Indoor Entering Air Temperature (Dry Bulb/Wet Bulb)							
	68/57°F		73/61°F		80/67°F		82/68°F	
	TC*	SHC**	TC	SHC	TC	SHC	TC	SHC
5	6300	4900	6600	5200	7600	5900	7900	6200
15	6900	5400	7300	5800	8400	6600	8800	6900
25	8400	6600	8900	7000	9700	7600	10600	8300
35	9200	7200	9800	7700	10400	8200	11200	8800
45	9000	7100	9600	7500	10300	8100	11000	8600
55	8800	6900	9300	7300	10200	8000	10900	8500
65	8500	6700	9100	7100	10000	7800	10700	8400
75	8200	6500	8800	6900	9700	7600	10500	8300
85	8000	6300	8600	6700	9500	7400	10300	8100
95	7800	6100	8400	6600	9400	7300	10100	7900
105	7600	5900	8100	6400	9100	7200	9900	7700
115	7400	5800	7900	6200	8900	7000	9600	7500
125	7100	5600	7600	5900	8500	6700	9300	7300

*Total Capacity **Sensible Heat Capacity

4TXK2309A10N/4MXW2309A10N - Heating Mode Performance Data

Outdoor Ambient Air Temperature (°F)	Indoor Entering Air Temperature			
	68°F	73°F	80°F	82°F
	TC*	TC	TC	TC
0	8900	8800	8600	8600
5	9900	9800	9600	9500
10	10300	10200	10000	9900
15	10800	10600	10400	10300
20	11400	11300	11100	11000
25	11600	11500	11200	11100
30	11900	11800	11600	11500
35	12200	12100	11800	11700
40	12300	12200	12000	11800
45	12400	12300	12100	12000
50	12600	12500	12200	12100
55	12700	12600	12300	12200
60	12800	12700	12400	12300
65	12900	12800	12600	12400
70	13000	12900	12700	12500
75	13200	13000	12800	12700
80	13400	13300	13000	12900

*Total Capacity

Capacities in these performance tables reflect normal operation at the temperatures indicated. See specification tables above for certified values under prescribed test conditions.

Performance Data

4TXK2312A10N/4MXW2312A10N - Cooling Mode Performance Data

Outdoor Ambient Air Temperature (°F)	Indoor Entering Air Temperature (Dry Bulb/Wet Bulb)							
	68/57°F		73/61°F		80/67°F		82/68°F	
	TC*	SHC**	TC	SHC	TC	SHC	TC	SHC
5	7200	5700	7700	6000	8300	6500	8400	6600
15	7900	6200	8400	6600	9500	7400	9600	7500
25	8700	6800	9300	7300	10600	8300	10800	8500
35	9200	7200	9800	7700	11100	8700	11300	8900
45	9700	7600	10400	8100	11600	9100	11800	9300
55	10200	8000	10900	8600	12000	9400	12400	9700
65	11200	8800	11900	9300	12900	10100	13200	10400
75	11500	9100	12300	9600	13200	10400	13500	10600
85	11100	8700	11800	9300	12900	10100	13200	10400
95	10500	8200	11200	8800	12300	9600	12700	9900
105	10000	7800	10700	8400	12000	9400	12300	9600
115	9400	7400	10100	7900	11300	8900	11600	9100
125	8600	6800	9000	7100	10200	8000	10500	8200

*Total Capacity **Sensible Heat Capacity

4TXK2312A10N/4MXW2312A10N - Heating Mode Performance Data

Outdoor Ambient Air Temperature (°F)	Indoor Entering Air Temperature			
	68°F	73°F	80°F	82°F
	TC*	TC	TC	TC
-5	6400	6300	6200	6100
0	7400	7200	7100	7000
5	7700	7600	7400	7400
10	8100	7900	7800	7700
15	8300	8100	8000	7900
20	8700	8500	8300	8300
25	9600	9400	9200	9200
30	10300	10100	9900	9900
35	11000	10800	10600	10600
40	11700	11500	11400	11300
45	12700	12500	12200	12200
50	13300	13000	12700	12600
55	13500	13200	12900	12800
60	13800	13400	13100	13000
65	14000	13700	13400	13300
70	14300	13900	13600	13500
75	14500	14100	13800	13700
80	14700	14300	14000	13900

*Total Capacity

Capacities in these performance tables reflect normal operation at the temperatures indicated. See specification tables above for certified values under prescribed test conditions.

Performance Data

4TXK2318A10N/4MXW2318A10N - Cooling Mode Performance Data

Outdoor Ambient Air Temperature (°F)	Indoor Entering Air Temperature (Dry Bulb/Wet Bulb)							
	68/57°F		73/61°F		80/67°F		82/68°F	
	TC*	SHC**	TC	SHC	TC	SHC	TC	SHC
5	11500	9000	12100	9500	13700	10700	14100	11000
15	11900	9300	12600	9800	14300	11300	14700	11600
25	13200	10300	14100	11100	16000	12500	16400	12900
35	15900	12500	17000	13300	18500	14500	19000	14900
45	17200	13500	18300	14300	19500	15300	20100	15800
55	16800	13200	17900	14100	19300	15200	19900	15600
65	16400	12800	17500	13700	19000	14900	19500	15300
75	15900	12500	17000	13300	18600	14600	19100	15000
85	15400	12100	16500	12900	18100	14200	18600	14600
95	15000	11800	16100	12600	17800	13900	18300	14300
105	14500	11400	15600	12200	17400	13700	17900	14100
115	13800	10800	14800	11600	16700	13100	17100	13400
125	13400	10500	14200	11200	16000	12600	16400	12900

*Total Capacity **Sensible Heat Capacity

4TXK2318A10N/4MXW2318A10N - Heating Mode Performance Data

Outdoor Ambient Air Temperature (°F)	Indoor Entering Air Temperature			
	68°F	73°F	80°F	82°F
	TC*	TC	TC	TC
-5	10200	10100	9900	9700
0	11300	11100	11000	10800
5	11800	11700	11500	11200
10	12400	12300	12000	11800
15	12700	12600	12400	12100
20	13300	13200	12900	12700
25	14600	14500	14300	14100
30	15700	15600	15400	15100
35	16800	16600	16400	16200
40	17800	17700	17500	17200
45	19400	19200	18900	18600
50	20300	20100	19700	19400
55	20600	20400	20000	19600
60	21000	20700	20400	20000
65	21400	21200	20800	20400
70	21700	21500	21100	20700
75	22000	21800	21400	21000
80	22400	22100	21700	21300

*Total Capacity

Capacities in these performance tables reflect normal operation at the temperatures indicated. See specification tables above for certified values under prescribed test conditions.

Performance Data

4TXK2324A10N/4MXW2324A10N - Cooling Mode Performance Data

Outdoor Ambient Air Temperature (°F)	Indoor Entering Air Temperature (Dry Bulb/Wet Bulb)							
	68/57°F		73/61°F		80/67°F		82/68°F	
	TC*	SHC**	TC	SHC	TC	SHC	TC	SHC
5	18100	14200	19200	15100	21100	16500	21700	17000
15	19000	14900	20100	15700	21900	17100	22700	17800
25	19800	15600	21200	16700	23100	18100	24200	19000
35	20800	16300	22300	17500	24500	19200	26000	20400
45	21300	16700	22900	18000	25100	19700	27000	21200
55	21000	16500	22500	17700	24600	19300	26700	20900
65	21100	16600	22500	17600	24000	18900	25900	20400
75	20700	16200	22000	17300	23500	18400	25200	19800
85	20100	15800	21500	16800	23000	18000	24600	19300
95	19200	15100	20600	16100	22500	17600	24600	19300
105	20600	16100	22100	17300	24700	19400	26600	20900
115	19400	15200	20900	16400	23400	18400	25300	19900
125	16000	12600	17200	13500	19400	15200	21000	16500

*Total Capacity **Sensible Heat Capacity

4TXK2324A10N/4MXW2324A10N - Heating Mode Performance Data

Outdoor Ambient Air Temperature (°F)	Indoor Entering Air Temperature			
	68°F	73°F	80°F	82°F
	TC*	TC	TC	TC
-5	17100	16800	16100	15800
0	18200	17900	17200	16800
5	18900	18600	17800	17400
10	20300	19900	19100	18700
15	22100	21800	20900	20400
20	23900	23600	22600	22100
25	23800	23400	22600	22100
30	24100	23800	23000	22600
35	24000	23700	22900	22500
40	23600	23300	22600	22200
45	23200	22900	22100	21600
50	23000	22600	21700	21100
55	23300	22900	21900	21400
60	23800	23400	22400	21800
65	24300	23800	22800	22300
70	24600	24200	23200	22600
75	25000	24600	23500	22900
80	25600	25100	24000	23500

*Total Capacity

Capacities in these performance tables reflect normal operation at the temperatures indicated. See specification tables above for certified values under prescribed test conditions.

Performance Data

4TXK2330A10N/4MXW2330A10N - Cooling Mode Performance Data

Outdoor Ambient Air Temperature (°F)	Indoor Entering Air Temperature (Dry Bulb/Wet Bulb)							
	68/57°F		73/61°F		80/67°F		82/68°F	
	TC*	SHC**	TC	SHC	TC	SHC	TC	SHC
5	22500	17600	23900	18700	26200	20600	26500	20800
15	23600	18500	25000	19600	27200	21300	27500	21500
25	24700	19400	26400	20700	28800	22600	29100	22800
35	25800	20300	27800	21800	30500	23900	30800	24100
45	26500	20800	28500	22300	31300	24500	31600	24800
55	26100	20500	28000	22000	30600	24000	30900	24200
65	26300	20600	28000	21900	29900	23500	30200	23700
75	25800	20200	27400	21500	29300	23000	29600	23200
85	25100	19700	26700	21000	28600	22400	28900	22700
95	23900	18700	25600	20100	28000	22000	28300	22200
105	26000	20400	27900	21900	31100	24400	31500	24700
115	26900	21100	28900	22600	32400	25400	32700	25600
125	20500	16100	22100	17300	24800	19500	25100	19700

*Total Capacity **Sensible Heat Capacity

4TXK2330A10N/4MXW2330A10N - Heating Mode Performance Data

Outdoor Ambient Air Temperature (°F)	Indoor Entering Air Temperature			
	68°F	73°F	80°F	82°F
	TC*	TC	TC	TC
-5	20800	20500	19700	19200
0	22200	21800	20900	20500
5	23000	22600	21700	21200
10	26100	25600	24600	24000
15	28500	28000	26800	26200
20	30800	30300	29100	28400
25	30600	30100	29000	28500
30	31000	30600	29600	29000
35	30900	30500	29500	29000
40	30300	30000	29100	28600
45	29900	29400	28400	27800
50	29600	29100	27900	27200
55	30000	29500	28200	27500
60	30600	30100	28800	28100
65	31200	30700	29300	28600
70	31700	31200	29800	29100
75	32100	31600	30200	29500
80	32900	32300	30900	30200

*Total Capacity

Capacities in these performance tables reflect normal operation at the temperatures indicated. See specification tables above for certified values under prescribed test conditions.

Performance Data

4TXK2336A10N/4MXW2336A10N - Cooling Mode Performance Data

Outdoor Ambient Air Temperature (°F)	Indoor Entering Air Temperature (Dry Bulb/Wet Bulb)							
	68/57°F		73/61°F		80/67°F		82/68°F	
	TC*	SHC**	TC	SHC	TC	SHC	TC	SHC
5	28100	22000	29900	23400	32800	25700	33100	26000
15	29500	23100	31200	24500	34000	26700	34300	26900
25	30900	24200	33000	25900	36000	28200	36300	28500
35	32300	25300	34700	27200	38100	29900	38500	30200
45	33100	26000	35600	27900	39100	30600	39500	30900
55	32700	25600	35000	27500	38200	30000	38600	30300
65	32800	25800	35000	27400	37400	29300	37800	29600
75	32200	25300	34200	26800	36600	28700	36900	29000
85	31300	24600	33400	26200	35800	28100	36100	28300
95	29900	23400	32000	25100	35000	27500	35400	27700
105	32400	25400	34800	27300	38900	30500	39300	30800
115	33600	26300	36100	28300	40500	31700	40900	32100
125	25600	20100	27600	21600	31100	24400	31400	24600

*Total Capacity **Sensible Heat Capacity

4TXK2336A10N/4MXW2336A10N - Heating Mode Performance Data

Outdoor Ambient Air Temperature (°F)	Indoor Entering Air Temperature			
	68°F	73°F	80°F	82°F
	TC*	TC	TC	TC
-5	24600	24200	23200	22700
0	26200	25800	24700	24200
5	27200	26700	25600	25100
10	30800	30300	29000	28400
15	33600	33100	31700	31000
20	36400	35800	34300	33600
25	36100	35600	34300	33600
30	36700	36100	34900	34300
35	36500	36000	34900	34300
40	35800	35400	34400	33800
45	35300	34800	33500	32900
50	35000	34400	32900	32100
55	35500	34800	33300	32500
60	36200	35500	34000	33200
65	36900	36200	34700	33800
70	37500	36800	35200	34400
75	38000	37300	35700	34800
80	38900	38200	36500	35700

*Total Capacity

Capacities in these performance tables reflect normal operation at the temperatures indicated. See specification tables above for certified values under prescribed test conditions.

Mechanical Specifications

Single Zone Outdoor Unit

General

This unit shall be fully charged from the factory for 25 feet (7.6m) of piping. This unit is designed to operate at outdoor ambient temperatures as high as 115°F (46°C). Cooling capacities with the mini-split air handler shown in the catalog are AHRI certified. The unit is ETL listed for outdoor application.

Unit Casing

The unit casing shall be constructed of heavy gauge, galvanized steel and painted with a weather-resistant powder paint.

Refrigerant Controls

Refrigeration system controls include condenser fan and compressor relay. High and low pressure controls are inherent to the compressor. A suction line multi function service valve is standard

Compressor

The compressor features internal over temperature and pressure protection; total dipped hermetic motor windings. Other features include: centrifugal oil pump and low vibration and noise.

Condenser Coil

The coil shall consist of aluminum finned coils brazed to copper tubing. The coil provides airflow resistance and efficient heat transfer. The coil is protected by the casing.

Low Ambient Cooling

Matched 23 Series Trane ductless products, have a cooling capability to 0°F (-18°C) and heating capability to -4° F (-20°C).

Single Zone Indoor High Wall

General

The High Wall mounted type air handler shall be completely factory assembled including coil, condensate drain pan, fan motor, washable filter, air purifying filter and electric controls to be used with a wireless remote controller. Unit shall be shipped with a unit mounting plate. Unit shall be matched with a Trane outdoor unit, rated and tested in accordance with AHRI standard. Unit shall be ETL listed.

Unit Casing

Casing shall be provided with knockouts on the right, and left of the unit to facilitate piping and electrical connection on either side of the unit. An electrical service cover shall be provided to permit easy access to the electrical terminal strip.

Discharge Airflow and Distribution System

Unit shall have auto swing, dual horizontal blades to optimize the aperture outlet for vertical airflow and air distribution. Blade shall close automatically when the air conditioner is turned off to minimize dust entering the unit. Five-Step preset program on the remote controller shall be available to control the blade angle.

Manually adjusted wide-angle louvers shall be provided to adjust the coverage and direction of airflow.

Controls

Units shall have the capability to be controlled remotely.

Remote Controller

The unit shall have an optional wireless infrared remote controller with an easily readable digital display panel to start, stop and regulate the air conditioner from a distance.

The wireless and wired controllers are available for all units. **(Sold separately)**

Healthy Filters

The unit shall have one combined active carbon and catechin filter with the unit. The filter needs to be cleaned at least once a year.



Trane - by Trane Technologies (NYSE: TT), a global climate innovator - creates comfortable, energy efficient indoor environments for commercial and residential applications. For more information, please visit trane.com or tranetechnologies.com.



The AHRI Certified mark indicates Trane U.S. Inc. participation in the AHRI Certification program. For verification of individual certified products, go to ahridirectory.org.

Trane has a policy of continuous data improvement and it reserves the right to change design and specifications without notice. We are committed to using environmentally conscious print practices.