



TRANE[®]

Upflow/ Horizontal Downflow /Horizontal Condensing, Direct Vent Gas-Fired Furnace

XT 95

TUH1B040A9H21B, TUH1B060A9H31B,
TUH1B080A9H31C, TUH1C100A9H41B,
TDH1B040A9H21B, TDH1B065A9H31B,
TDH1C085A9H41B, TDH1D110A9H51B

High Efficiency Single-Stage Fan Assisted
Combustion System

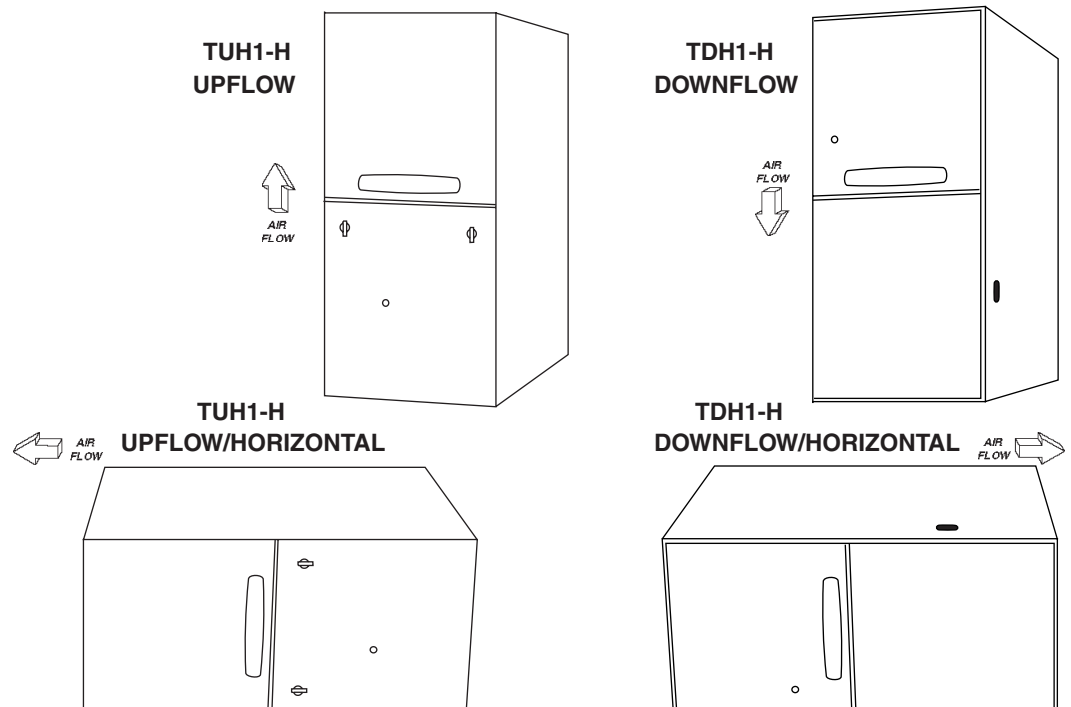



General Features

NATURAL GAS MODELS

Central Heating furnace designs are certified to ANSI Z21.47 / CSA 2.3 for both natural and L.P. gas. Limit setting and rating data were established and approved under standard rating conditions using American National Standards Institute standards.

SAFE OPERATION

The Integrated System Control has solid state devices, which continuously monitor for presence of flame, when the system is in the heating mode of operation. Dual solenoid combination gas valve and regulator provide extra safety.

QUICK HEATING

Durable, cycle tested, heavy gauge **aluminized steel heat exchanger** quickly transfers heat to provide warm conditioned air to the structure. **Low energy power vent blower**, to increase efficiency and provide a positive discharge of gas fumes to the outside.

BURNERS

Multiport Inshot burners will give years of quiet and efficient service. All models can be converted to **L.P. gas** without changing burners.

INTEGRATED SYSTEM CONTROL

Exclusively designed operational program provides total control of furnace limit sensors, blowers, gas valve, flame control and includes self diagnostics for ease of service. Also contains connection points for E.A.C./humidifier.

ENERGY EFFICIENT OPERATION

Furnace is certified to leak 2% or less of nominal air conditioning CFM delivered when pressurized to .5" water column with all inlets, outlets, and drains sealed.

AIR DELIVERY

The four speed, direct drive blower motor, has sufficient airflow for most heating and cooling requirements, will switch from heating to cooling speeds on demand from room thermostat. The blower door safety switch will prevent or terminate furnace operation when the blower door is removed.

STYLING

Heavy gauge steel and "wrap-around" cabinet construction is used in the cabinet with baked-on enamel finish for strength and beauty. The heat exchanger section of the cabinet is completely lined with foil faced fiberglass insulation. This results in quiet and efficient operation due to the excellent acoustical and insulating qualities of fiberglass. Built-in bottom pan and alternate bottom, left or right side return air connection provision.

FEATURES AND GENERAL OPERATION

The XT95 High Efficiency Gas Furnaces employ a Silicon Nitride Hot Surface Ignition system, which eliminates the waste of a constant burning pilot. The integrated system control lights the main burners upon a demand for heat from the room thermostat. Complete front service access.

- Low energy power venter
- Vent proving pressure switch.

Features and Benefits

XT95 Standard Equipment

- Power supply 115/1/60
- Convertible to horizontal with left of right airflow
- **Type 29-4C™** stainless steel secondary heat exchanger
- Inner blower doors
- Constant torque ECM blower motor
- Silicon Nitride igniter with adaptive heat up
- Accessory hook-up capability – Hum and EAC
- Quiet induced draft blower
- Blower door safety switch
- Dual solenoid combination gas valve & regulator
- PVC venting – 1 or 2 pipe vent option
- Left/right gas connection
- Selectable cooling fan off delay eliminates need for BAY24X045 time delay relay
- Single wire twinning
- Integrated solid state control with self-diagnostics
- 24 volt fuse
- Manual reset burner box limit
- **Optional extended warranties**

Contents

General Features	2
Features and Benefits	2
XT95 Standard Equipment	2
XT95 Optional Equipment	4
General Data	5
TUH1B040A9H21B	5
TUH1B060A9H31B	5
TUH1B080A9H31C	5
TUH1C100A9H41B	6
TDH1B040A9H21B	6
TDH1B065A9H31B	6
TDH1C085A9H41B	7
TDH1D110A9H51B	7
Performance Data	8
Electrical Data	10
Field Wiring	14
Twinning Field Wiring	15
Dimensions	16



Features and Benefits

XT95 Optional Equipment

Comfort Control, XL803, Programmable 7 Day, 3-Ht, 2-Cl.....	TCONT803AS32DA []
Comfort Control, XR402, Electric, 3-Ht, 2-Cl (Non-programmable).....	TCONT402AN32DA []
For additional comfort control choices, see the product catalog or quick select handbook	
Propane Conversion Kit.....	BAYLPKT210B []
Propane Conversion Kit (stainless steel burners).....	BAYLPSS210B []
Downflow Subbase.....	BAYBASE205 []
Filter Access Door Kit.....	BAYFLTR206 []
Side Filter Rack.....	BAYFLTR200 []
High Altitude Pressure Switch Kit TUH1B040, TDH1B040, TDH1C085.....	BAYSWT01AHALTA []
High Altitude Pressure Switch Kit TUH1B060, TUH1D100, TUH1D120.....	BAYSWT04AHALTA []
High Altitude Pressure Switch Kit TUH1B080, TUH1C100, TDH1D110.....	BAYSWT05AHALTA []
High Altitude Pressure Switch Kit TUH1C080.....	BAYSWT11AHALTA []
High Altitude Pressure Switch Kit TDH1B065.....	BAYSWT12AHALTA []
Concentric Vent Kit.....	BAYAIR30AVENTA []
Sidewall Vent Termination Kit.....	BAYVENT200B []
Manufactured/Mobile Home Kit.....	BAYMFGH100A []



General Data

PRODUCT SPECIFICATIONS ^①

MODEL	TUH1B040A9H21B	TUH1B060A9H31B	TUH1B080A9H31C
TYPE	Upflow/Horizontal	Upflow/Horizontal	Upflow/Horizontal
RATINGS ^②			
Input BTUH ^③	40,000	60,000	77,000
Capacity BTUH (ICS) ^③	38,000	57,000	73,150
AFUE (Upflow / Horizontal)	95.0 / 94.2	95.0 ^⑥ / 94.2	95.0 ^⑥ / 94.2
Temp. rise (Min.-Max.) °F.	30 - 60	30 - 60	35 - 65
BLOWER DRIVE ^⑤	DIRECT	DIRECT	DIRECT
Diameter - Width (In.)	10 x 7	10 x 7	10 x 8
No. Used	1	1	1
Speeds (No.)	4	4	4
CFM vs. in. w.g.	See Fan Performance Table	See Fan Performance Table	See Fan Performance Table
Motor HP	1/2	1/2	1/2
R.P.M.	1075	1075	1075
Volts/Ph/Hz	115/1/60	115/1/60	115/1/60
FLA	6.8	6.8	6.8
COMBUSTION FAN — Type	Centrifugal	Centrifugal	Centrifugal
Drive - No. Speeds	Direct - 1	Direct - 1	Direct - 1
Motor HP - RPM	1/55 - 3000	1/15 - 3450	1/20 - 3450
Volts/Ph/Hz	115/1/60	115/1/60	115/1/60
FLA	1.00	1.75	0.70
FILTER — Furnished?	Yes	Yes	Yes
Type Recommended	High Velocity	High Velocity	High Velocity
Shipped (No.-Size-Thk.)	1 - 17x25 - 1in.	1 - 17x25 - 1in.	1 - 17x25 - 1in.
VENT PIPE DIAMETER - Min (in.) ^{⑥⑦}	2 Round	2 Round	2 Round
HEAT EXCHANGER			
Type - Fired	Alum. Steel	Alum. Steel	Alum. Steel
- Unfired			
Gauge (Fired)	20	20	20
ORIFICES — Main			
Nat. Gas. Qty. — Drill Size	2 — 45	3 — 45	4 — 45
L.P. Gas Qty. — Drill Size	2 — 56	3 — 56	4 — 56
GAS VALVE	Redundant - Single Stage	Redundant - Single Stage	Redundant - Single Stage
PILO SAFETY DEVICE			
Type	Hot Surface Ignition	Hot Surface Ignition	Hot Surface Ignition
BURNERS — Type	Multiport Inshot	Multiport Inshot	Multiport Inshot
Number	2	3	4
POWER CONN. — V/Ph/Hz ^④	115/1/60	115/1/60	115/1/60
Ampacity (In Amps)	9.7	10.4	9.4
Max. Overcurrent Protection (Amps)	15	15	15
PIPE CONN. SIZE (IN.)	1/2	1/2	1/2
DIMENSIONS			
Crated (In.)	H x W x D 41-3/4 x 19-1/2 x 30-1/2	H x W x D 41-3/4 x 19-1/2 x 30-1/2	H x W x D 41-3/4 x 19-1/2 x 30-1/2
WEIGHT			
Shipping (Lbs.)/Net (Lbs.)	139 / 129	150 / 140	158 / 148

① Central Furnace heating designs are certified to ANSI Z21.47 / CSA 2.3.

② For U.S. applications, above input ratings (BTUH) are up to 2,000 feet, derate 4% per 1,000 feet for elevations above 2,000 feet above sea level.

For Canadian applications, above input ratings (BTUH) are up to 4,500 feet, derate 4% per 1,000 feet for elevations above 4,500 feet above sea level.

③ Based on U.S. government standard tests.

④ The above wiring specifications are in accordance with National Electrical Code; however, installations must comply with local codes.

⑤ 4 Speed constant torque high efficiency ECM blower motor

⑥ Refer to the Vent Length Table in the Installer's Guide or the Allowable Vent Length label located on the furnace.

⑦ All TUH1 and TDH1 furnace models have a vent outlet diameter that equals 2".

⑧ Energy Star



General Data

PRODUCT SPECIFICATIONS ^①

MODEL	TUH1C100A9H41B	TDH1B040A9H21B	TDH1B065A9H31B
TYPE	Upflow/Horizontal	Downflow/Horizontal	Downflow/Horizontal
RATINGS ^②			
Input BTUH ^③	97,000	40,000	60,000
Capacity BTUH (ICS) ^③	92,105	38,000	57,000
AFUE (Upflow / Horizontal)	95.0 ^⑥ / 94.2	95	95 ^⑥
Temp. rise (Min.-Max.) °F	35 - 65	30 - 60	25 - 55
BLOWER DRIVE ^⑤	DIRECT	DIRECT	DIRECT
Diameter - Width (In.)	11 x 10	10 x 7	10 x 8
No. Used	1	1	1
Speeds (No.)	4	4	4
CFM vs. in. w.g.	See Fan Performance Table	See Fan Performance Table	See Fan Performance Table
Motor HP	3/4	1/2	3/4
R.P.M.	1100	1080	1075
Volts/Ph/Hz	115/1/60	115/1/60	115/1/60
FLA	8.4	6.8	8.4
COMBUSTION FAN — Type	Centrifugal	Centrifugal	Centrifugal
Drive - No. Speeds	Direct - 1	Direct - 1	Direct - 1
Motor HP - RPM	1/20 - 3450	1/55 - 3000	1/25 - 3200
Volts/Ph/Hz	115/1/60	115/1/60	115/1/60
FLA	.70	1.00	1.35
FILTER — Furnished?	Yes	Yes	Yes
Type Recommended	High Velocity	High Velocity	High Velocity
Shipped (No.-Size-Thk.)	1 - 20x25 - 1in.	1 - 14x20 - 1in.	2 - 14x20 - 1in.
VENT PIPE DIAMETER - Min (in.) ^{⑥⑦}	3 Round	2 Round	2 Round
HEAT EXCHANGER			
Type - Fired	Alum. Steel	Alum. Steel	Alum. Steel
- Unfired			
Gauge (Fired)	20	20	20
ORIFICES — Main			
Nat. Gas. Qty. — Drill Size	5 — 45	2 — 45	4 — 48
L.P. Gas Qty. — Drill Size	5 — 56	2 — 56	4 — 56
GAS VALVE	Redundant - Single Stage	Redundant - Single Stage	Redundant - Single Stage
PILOT SAFETY DEVICE			
Type	Hot Surface Ignition	Hot Surface Ignition	Hot Surface Ignition
BURNERS — Type	Multiport Inshot	Multiport Inshot	Multiport Inshot
Number	5	2	4
POWER CONN. — V/Ph/Hz ^④	115/1/60	115/1/60	115/1/60
Ampacity (In Amps)	11.4	9.7	12.0
Max. Overcurrent Protection (Amps)	15	15	15
PIPE CONN. SIZE (IN.)	1/2	1/2	1/2
DIMENSIONS	H x W x D	H x W x D	H x W x D
Crated (In.)	41-3/4 x 23 x 30-1/2	41-3/4 x 19-1/2 x 30-1/2	41-3/4 x 19-1/2 x 30-1/2
WEIGHT			
Shipping (Lbs.)/Net (Lbs.)	171 / 160	145 / 135	158 / 148

① Central Furnace heating designs are certified to ANSI Z21.47 / CSA 2.3.

② For U.S. applications, above input ratings (BTUH) are up to 2,000 feet, derate 4% per 1,000 feet for elevations above 2,000 feet above sea level.

For Canadian applications, above input ratings (BTUH) are up to 4,500 feet, derate 4% per 1,000 feet for elevations above 4,500 feet above sea level.

③ Based on U.S. government standard tests.

④ The above wiring specifications are in accordance with National Electrical Code; however, installations must comply with local codes.

⑤ 4 Speed constant torque high efficiency ECM blower motor

⑥ Refer to the Vent Length Table in the Installer's Guide or the Allowable Vent Length label located on the furnace.

⑦ All TUH1 and TDH1 furnace models have a vent outlet diameter that equals 2".

⑧ Energy Star



General Data

PRODUCT SPECIFICATIONS ^①

MODEL	TDH1C085A9H41B	TDH1D110A9H51B
TYPE	Downflow/Horizontal	Downflow/Horizontal
RATINGS ^②		
Input BTUH ^③	80,000	110,000
Capacity BTUH (ICS) ^③	76,000	104,500
AFUE	95 ^⑥	95 ^⑥
Temp. rise (Min.-Max.) °F	30 - 60	35 - 65
BLOWER DRIVE ^⑤	DIRECT	DIRECT
Diameter - Width (In.)	11 x 10	11 x 10
No. Used	1	1
Speeds (No.)	4	4
CFM vs. in. w.g.	See Fan Performance Table	See Fan Performance Table
Motor HP	3/4	1
R.P.M.	1075	1075
Volts/Ph/Hz	115/1/60	115/1/60
FLA	8.4	10.9
COMBUSTION FAN — Type	Centrifugal	Centrifugal
Drive - No. Speeds	Direct - 1	Direct - 1
Motor HP - RPM	1/20 - 3450	1/20 - 3450
Volts/Ph/Hz	115/1/60	115/1/60
FLA	.70	.70
FILTER — Furnished?	Yes	Yes
Type Recommended	High Velocity	High Velocity
Shipped (No.-Size-Thk.)	2 - 16x20 - 1in.	2 - 16x20 - 1in.
VENT PIPE DIAMETER - Min (in.) ^{⑥⑦}	2.5 Round	2.5 Round
HEAT EXCHANGER		
Type - Fired	Alum. Steel	Alum. Steel
- Unfired		
Gauge (Fired)	20	20
ORIFICES — Main		
Nat. Gas. Qty. — Drill Size	5 — 48	6 — 48
L.P. Gas Qty. — Drill Size	5 — 56	6 — 56
GAS VALVE	Redundant - Single Stage	Redundant - Single Stage
PILOT SAFETY DEVICE		
Type	Hot Surface Ignition	Hot Surface Ignition
BURNERS — Type	Multiport Inshot	Multiport Inshot
Number	5	6
POWER CONN. — V/Ph/Hz ^④	115/1/60	115/1/60
Ampacity (In Amps)	11.4	14.5
Max. Overcurrent Protection (Amps)	15	15
PIPE CONN. SIZE (IN.)	1/2	1/2
DIMENSIONS	H x W x D	H x W x D
Crated (In.)	41-3/4 x 23 x 30-1/2	41-3/4 x 26-1/2 x 30-1/2
WEIGHT		
Shipping (Lbs.)/Net (Lbs.)	171 / 160	205 / 193

① Central Furnace heating designs are certified to ANSI Z21.47 / CSA 2.3.

② For U.S. applications, above input ratings (BTUH) are up to 2,000 feet, derate 4% per 1,000 feet for elevations above 2,000 feet above sea level.

For Canadian applications, above input ratings (BTUH) are up to 4,500 feet, derate 4% per 1,000 feet for elevations above 4,500 feet above sea level.

③ Based on U.S. government standard tests.

④ The above wiring specifications are in accordance with National Electrical Code; however, installations must comply with local codes.

⑤ 4 Speed constant torque high efficiency ECM blower motor

⑥ Refer to the Vent Length Table in the Installer's Guide or the Allowable Vent Length label located on the furnace.

⑦ All TUH1 and TDH1 furnace models have a vent outlet diameter that equals 2".

⑧ Energy Star



Performance Data

FURNACE AIRFLOW (CFM) VS. STATIC PRESSURE (ins.w.g.)										
MODEL	SPEED TAP	0.1	0.2	0.3	0.4	0.5	0.6	0.7	0.8	0.9
TUH1B040A9H21B	4 - HIGH - Black	1159	1131	1102	1077	1052	1022	992	961	930
	3 - MED-HIGH - Blue	938	910	881	851	820	786	751	717	662
	2 - MED-LOW - Yellow	844	814	783	750	717	681	645	604	563
	1 - LOW - Red**	772	732	691	656	621	581	540	497	454
TUH1B060A9H31B	4 - HIGH - Black	1402	1362	1318	1267	1214	1157	1095	1033	960
	3 - MED-HIGH - Blue**	1199	1174	1149	1127	1099	1075	1028	973	897
	2 - MED-LOW - Yellow	1104	1080	1053	1031	1002	980	955	931	890
	1 - LOW - Red	834	808	770	750	712	677	641	599	566
TUH1B080A9H31C	4 - HIGH - Black	1328	1304	1277	1253	1224	1182	1127	1057	959
	3 - MED-HIGH - Blue**	1519	1493	1464	1422	1368	1306	1242	1161	1054
	2 - MED-LOW - Yellow	1072	1039	1015	991	956	928	891	858	828
	1 - LOW - Red	810	782	759	729	703	668	643	612	582
TUH1C100A9H41B	4 - HIGH - Black	1586	1552	1517	1477	1443	1410	1366	1331	1289
	3 - MED-HIGH - Blue**	1893	1858	1826	1793	1759	1724	1691	1646	1582
	2 - MED-LOW - Yellow	1364	1320	1282	1241	1205	1167	1120	1078	1045
	1 - LOW - Red	1107	1060	1003	959	919	863	825	782	730

** = Factory Set Heat Speed Tap Setting

CFM VS. TEMPERATURE RISE																		
MODEL	CFM (CUBIC FEET PER MINUTE)																	
	600	700	800	900	1000	1100	1200	1300	1400	1500	1600	1700	1800	1900	2000	2100	2200	2300
TUH1B040A9H21B	59	50	44	39	35	32	29											
TUH1B060A9H31B				59	53	48	44	41	38									
TUH1B080A9H31C						64	59	54	50	47	44	41						
TUH1C100A9H41B								66	61	57	53	50	47	45	43			



Performance Data

FURNACE AIRFLOW (CFM) VS. STATIC PRESSURE (ins.w.g.)										
MODEL	SPEED TAP	0.1	0.2	0.3	0.4	0.5	0.6	0.7	0.8	0.9
TDH1B040A9H21B	4 - HIGH - Black	1156	1128	1100	1072	1043	1012	981	917	852
	3 - MED-HIGH - Blue	935	859	859	828	797	757	717	679	641
	2 - MED-LOW - Yellow**	835	803	771	736	701	652	602	569	536
	1 - LOW - Red	752	726	700	648	596	554	511	471	431
TDH1B065A9H31B	4 - HIGH - Black	1455	1404	1352	1299	1232	1174	1101	1025	916
	3 - MED-HIGH - Blue**	1375	1350	1320	1270	1215	1153	1099	1014	934
	2 - MED-LOW - Yellow	1099	1076	1044	1021	994	968	941	904	874
	1 - LOW - Red	838	799	773	744	706	675	628	599	558
TDH1C085A9H41B	4 - HIGH - Black	1795	1763	1732	1701	1669	1627	1575	1514	1451
	3 - MED-HIGH - Blue**	1686	1655	1619	1586	1554	1525	1494	1458	1415
	2 - MED-LOW - Yellow	1395	1362	1328	1289	1258	1225	1186	1151	1115
	1 - LOW - Red	1179	1141	1094	1059	1019	970	931	888	846
TDH1D110A9H51B	4 - HIGH - Black	2105	2063	2010	1951	1880	1802	1721	1630	1543
	3 - MED-HIGH - Blue**	1880	1853	1817	1785	1747	1708	1649	1579	1499
	2 - MED-LOW - Yellow	1756	1718	1688	1647	1616	1576	1546	1505	1468
	1 - LOW - Red	1582	1553	1509	1473	1433	1397	1362	1317	1282

** = Factory Set Heat Speed Tap Setting

CFM VS. TEMPERATURE RISE																		
MODEL	CFM (CUBIC FEET PER MINUTE)																	
	600	700	800	900	1000	1100	1200	1300	1400	1500	1600	1700	1800	1900	2000	2100	2200	2300
TDH1B040A9H21B	59	50	44	39	35	32	29											
TDH1B065A9H31B					53	48	44	41	38	35								
TDH1C085A9H41B							59	54	50	47	44	41	39					
TDH1D110A9H51B										65	60	57	54	51	48	46		

Electrical Data

TUH1-H Schematic

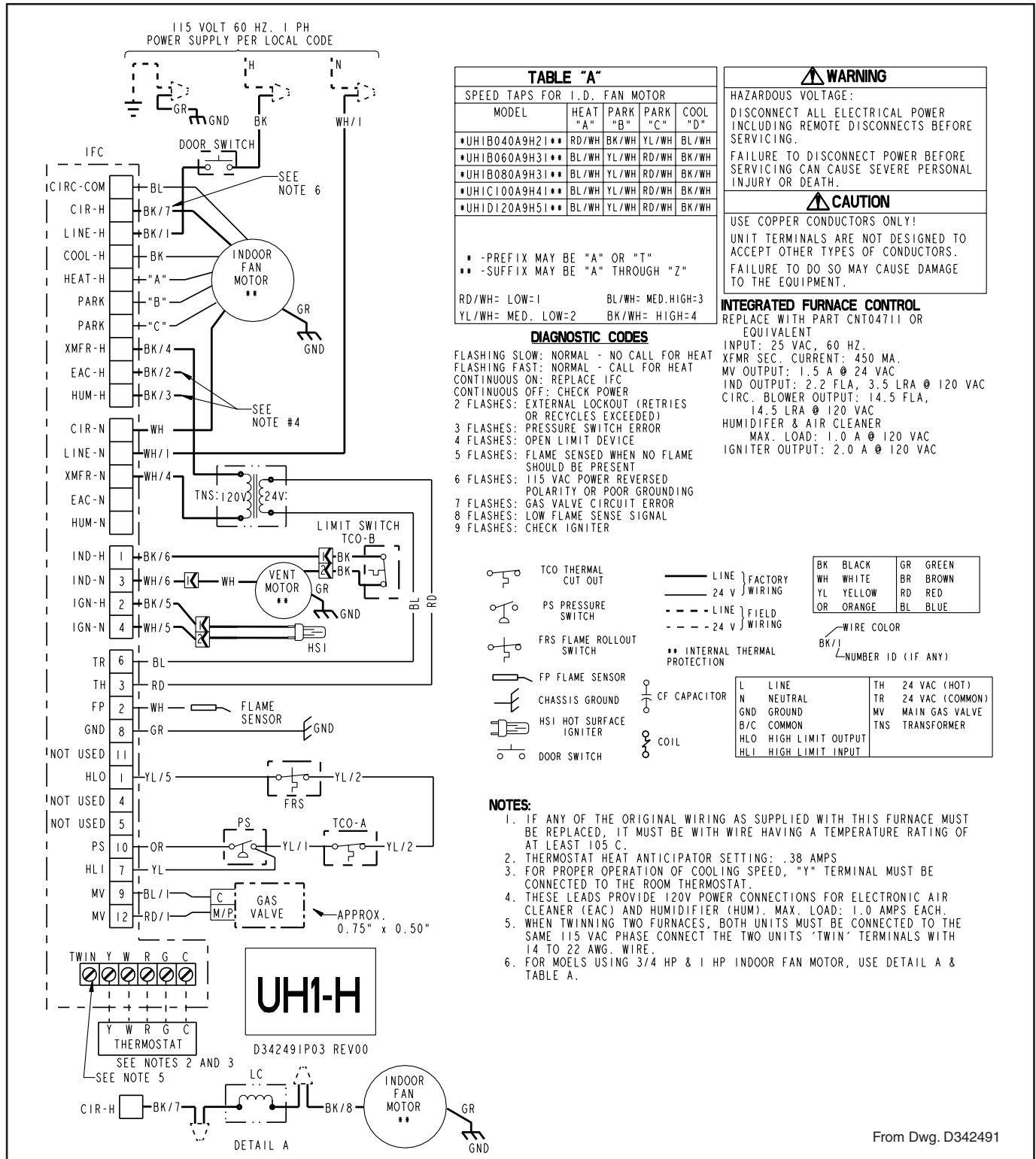

TABLE "A"				
SPEED TAPS FOR I.D. FAN MOTOR				
MODEL	HEAT "A"	PARK "B"	PARK "C"	COOL "D"
*UH1B040A9H21**	RD/WH	BK/WH	YL/WH	BL/WH
*UH1B060A9H31**	BL/WH	YL/WH	RD/WH	BK/WH
*UH1B080A9H31**	BL/WH	YL/WH	RD/WH	BK/WH
*UH1C100A9H41**	BL/WH	YL/WH	RD/WH	BK/WH
*UH1D120A9H51**	BL/WH	YL/WH	RD/WH	BK/WH

* -PREFIX MAY BE "A" OR "T"
 ** -SUFFIX MAY BE "A" THROUGH "Z"

RD/WH= LOW=1 BL/WH= MED.HIGH=3
 YL/WH= MED. LOW=2 BK/WH= HIGH=4

DIAGNOSTIC CODES

FLASHING SLOW: NORMAL - NO CALL FOR HEAT
 FLASHING FAST: NORMAL - CALL FOR HEAT
 CONTINUOUS ON: REPLACE IFC
 CONTINUOUS OFF: CHECK POWER
 2 FLASHES: EXTERNAL LOCKOUT (RETRIES OR RECYCLES EXCEEDED)
 3 FLASHES: PRESSURE SWITCH ERROR
 4 FLASHES: OPEN LIMIT DEVICE
 5 FLASHES: FLAME SENSED WHEN NO FLAME SHOULD BE PRESENT
 6 FLASHES: 115 VAC POWER REVERSED POLARITY OR POOR GROUNDING
 7 FLASHES: GAS VALVE CIRCUIT ERROR
 8 FLASHES: LOW FLAME SENSE SIGNAL
 9 FLASHES: CHECK IGNITER

WARNING

HAZARDOUS VOLTAGE:
 DISCONNECT ALL ELECTRICAL POWER INCLUDING REMOTE DISCONNECTS BEFORE SERVICING.
 FAILURE TO DISCONNECT POWER BEFORE SERVICING CAN CAUSE SEVERE PERSONAL INJURY OR DEATH.

CAUTION

USE COPPER CONDUCTORS ONLY!
 UNIT TERMINALS ARE NOT DESIGNED TO ACCEPT OTHER TYPES OF CONDUCTORS.
 FAILURE TO DO SO MAY CAUSE DAMAGE TO THE EQUIPMENT.

INTEGRATED FURNACE CONTROL
 REPLACE WITH PART CNT04711 OR EQUIVALENT

INPUT: 25 VAC, 60 HZ.
 XFMR SEC. CURRENT: 450 MA.
 MV OUTPUT: 1.5 A @ 24 VAC
 IND OUTPUT: 2.2 FLA, 3.5 LRA @ 120 VAC
 CIRC. BLOWER OUTPUT: 14.5 FLA, 14.5 LRA @ 120 VAC
 HUMIDIFIER & AIR CLEANER
 MAX. LOAD: 1.0 A @ 120 VAC
 IGNITER OUTPUT: 2.0 A @ 120 VAC

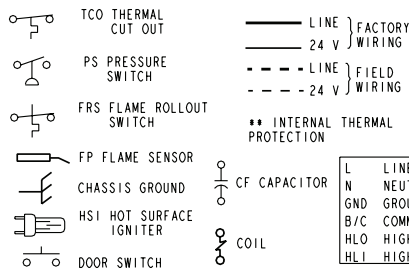

BK	BLACK	GR	GREEN
WH	WHITE	BR	BROWN
YL	YELLOW	RD	RED
OR	ORANGE	BL	BLUE

WIRE COLOR

BK/1 NUMBER ID (IF ANY)

L	LINE	TH	24 VAC (HOT)
N	NEUTRAL	TR	24 VAC (COMMON)
GND	GROUND	MV	MAIN GAS VALVE
B/C	COMMON	TNS	TRANSFORMER
HLO	HIGH LIMIT OUTPUT		
HLI	HIGH LIMIT INPUT		

- NOTES:**
- IF ANY OF THE ORIGINAL WIRING AS SUPPLIED WITH THIS FURNACE MUST BE REPLACED, IT MUST BE WITH WIRE HAVING A TEMPERATURE RATING OF AT LEAST 105 C.
 - THERMOSTAT HEAT ANTICIPATOR SETTING: .38 AMPS
 - FOR PROPER OPERATION OF COOLING SPEED, "Y" TERMINAL MUST BE CONNECTED TO THE ROOM THERMOSTAT.
 - THESE LEADS PROVIDE 120V POWER CONNECTIONS FOR ELECTRONIC AIR CLEANER (EAC) AND HUMIDIFIER (HUM). MAX. LOAD: 1.0 AMPS EACH.
 - WHEN TWINNING TWO FURNACES, BOTH UNITS MUST BE CONNECTED TO THE SAME 115 VAC PHASE CONNECT THE TWO UNITS 'TWIN' TERMINALS WITH 14 TO 22 AWG. WIRE.
 - FOR MOELS USING 3/4 HP & 1 HP INDOOR FAN MOTOR, USE DETAIL A & TABLE A.

UH1-H
 D342491P03 REV00

Electrical Data

TDH1-H Wiring

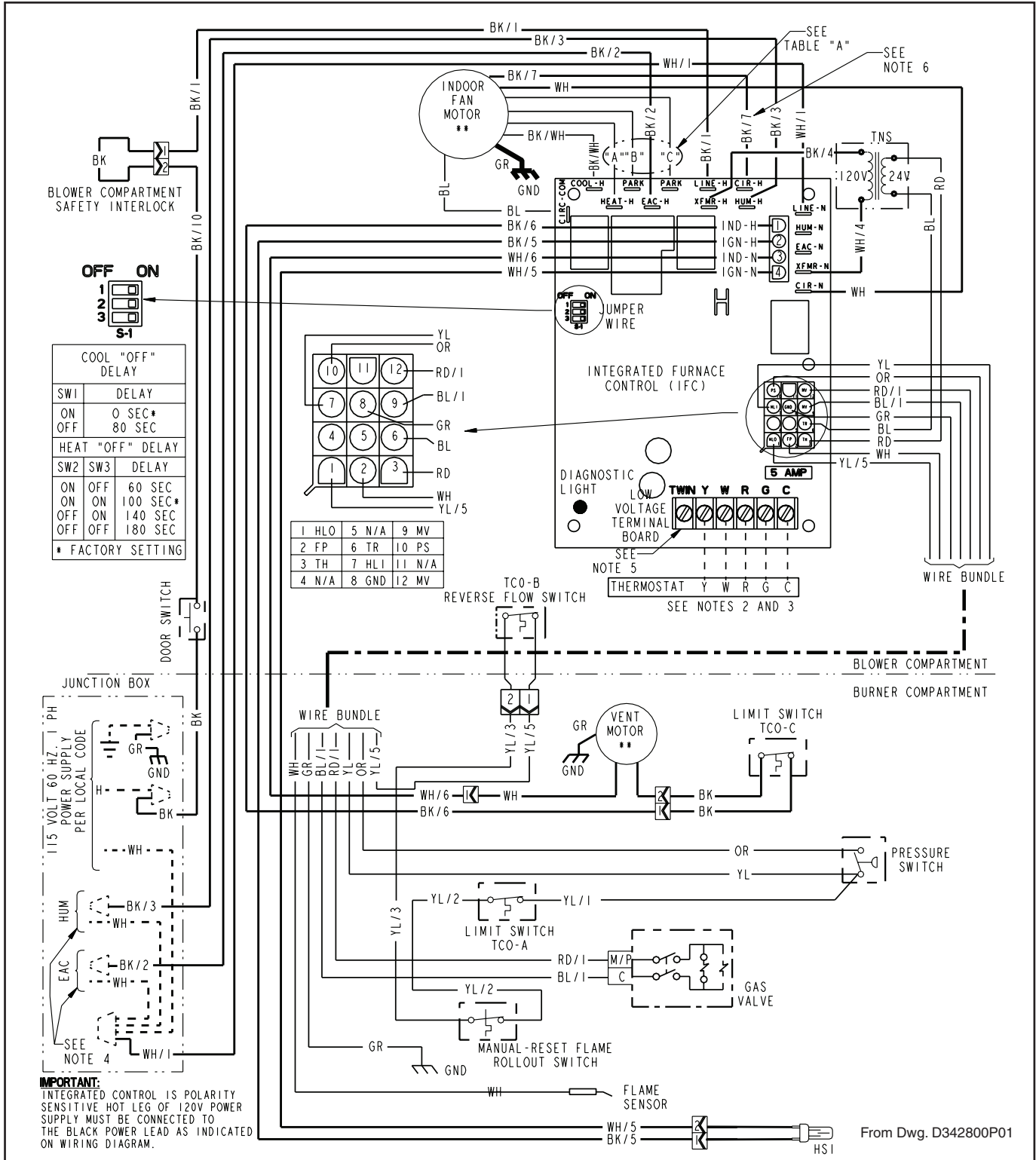

Electrical Data

TDH1-H Schematic

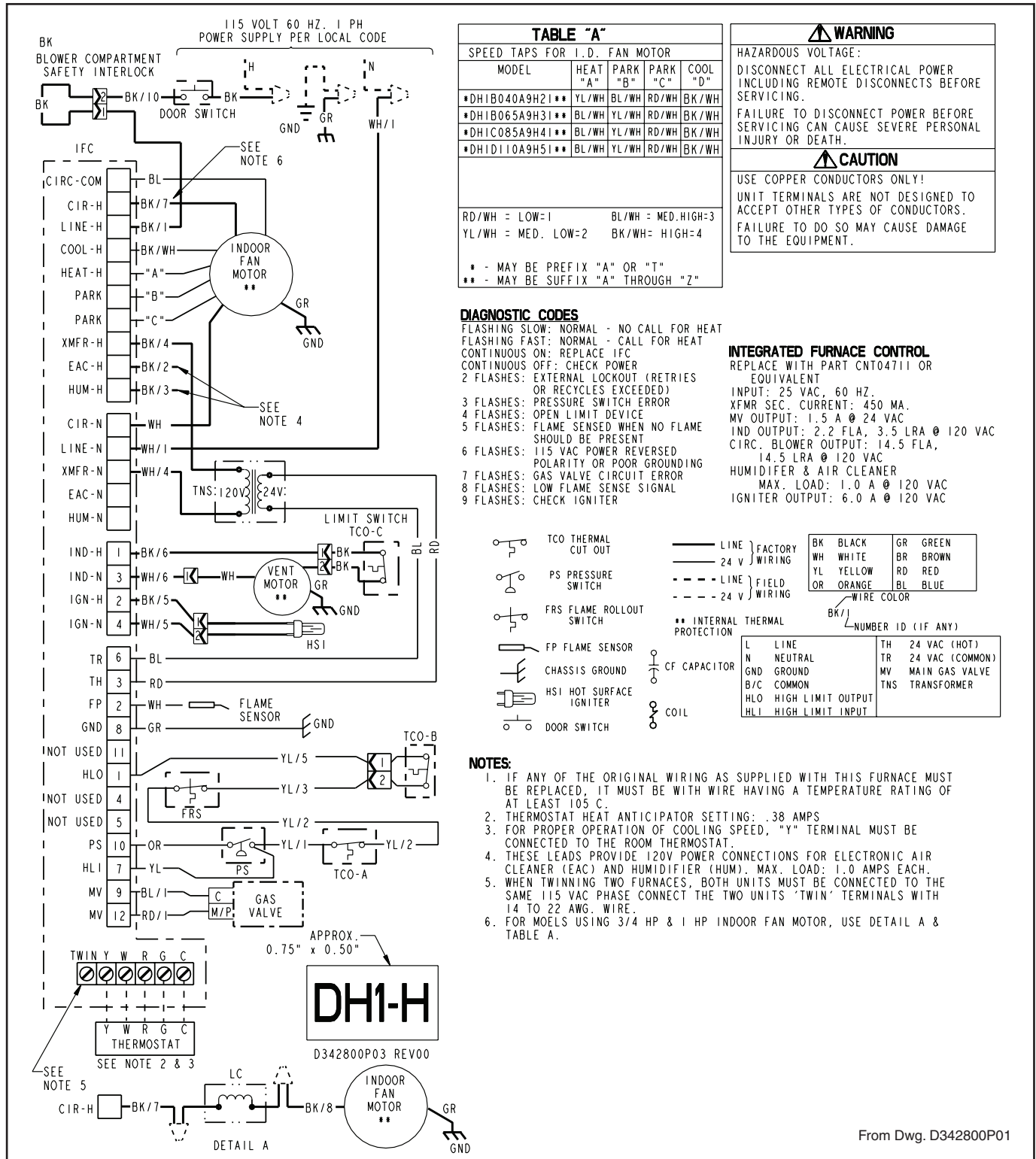

TABLE "A"				
SPEED TAPS FOR I.D. FAN MOTOR				
MODEL	HEAT "A"	PARK "B"	PARK "C"	COOL "D"
*DH1B040A9H21**	YL/WH	BL/WH	RD/WH	BK/WH
*DH1B065A9H31**	BL/WH	YL/WH	RD/WH	BK/WH
*DH1C085A9H41**	BL/WH	YL/WH	RD/WH	BK/WH
*DH1D110A9H51**	BL/WH	YL/WH	RD/WH	BK/WH

RD/WH = LOW=1 BL/WH = MED.HIGH=3
YL/WH = MED. LOW=2 BK/WH = HIGH=4

* - MAY BE PREFIX "A" OR "T"
** - MAY BE SUFFIX "A" THROUGH "Z"

WARNING

HAZARDOUS VOLTAGE:
DISCONNECT ALL ELECTRICAL POWER INCLUDING REMOTE DISCONNECTS BEFORE SERVICING.
FAILURE TO DISCONNECT POWER BEFORE SERVICING CAN CAUSE SEVERE PERSONAL INJURY OR DEATH.

CAUTION

USE COPPER CONDUCTORS ONLY!
UNIT TERMINALS ARE NOT DESIGNED TO ACCEPT OTHER TYPES OF CONDUCTORS.
FAILURE TO DO SO MAY CAUSE DAMAGE TO THE EQUIPMENT.

DIAGNOSTIC CODES

FLASHING SLOW: NORMAL - NO CALL FOR HEAT
FLASHING FAST: NORMAL - CALL FOR HEAT
CONTINUOUS ON: REPLACE IFC
CONTINUOUS OFF: CHECK POWER
2 FLASHES: EXTERNAL LOCKOUT (RETRIES OR RECYCLES EXCEEDED)
3 FLASHES: PRESSURE SWITCH ERROR
4 FLASHES: OPEN LIMIT DEVICE
5 FLASHES: FLAME SENSED WHEN NO FLAME SHOULD BE PRESENT
6 FLASHES: 115 VAC POWER REVERSED POLARITY OR POOR GROUNDING
7 FLASHES: GAS VALVE CIRCUIT ERROR
8 FLASHES: LOW FLAME SENSE SIGNAL
9 FLASHES: CHECK IGNITER

INTEGRATED FURNACE CONTROL

REPLACE WITH PART CNT04711 OR EQUIVALENT
INPUT: 25 VAC, 60 HZ.
XFMR SEC. CURRENT: 450 MA.
MV OUTPUT: 1.5 A @ 24 VAC
IND OUTPUT: 2.2 FLA, 3.5 LRA @ 120 VAC
CIRC. BLOWER OUTPUT: 14.5 FLA, 14.5 LRA @ 120 VAC
HUMIDIFIER & AIR CLEANER
MAX. LOAD: 1.0 A @ 120 VAC
IGNITER OUTPUT: 6.0 A @ 120 VAC

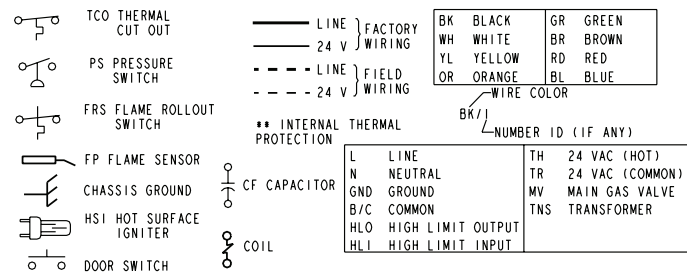

- NOTES:**
- IF ANY OF THE ORIGINAL WIRING AS SUPPLIED WITH THIS FURNACE MUST BE REPLACED, IT MUST BE WITH WIRE HAVING A TEMPERATURE RATING OF AT LEAST 105 C.
 - THERMOSTAT HEAT ANTICIPATOR SETTING: .38 AMPS
 - FOR PROPER OPERATION OF COOLING SPEED, "Y" TERMINAL MUST BE CONNECTED TO THE ROOM THERMOSTAT.
 - THESE LEADS PROVIDE 120V POWER CONNECTIONS FOR ELECTRONIC AIR CLEANER (EAC) AND HUMIDIFIER (HUM). MAX. LOAD: 1.0 AMPS EACH.
 - WHEN TWINNING TWO FURNACES, BOTH UNITS MUST BE CONNECTED TO THE SAME 115 VAC PHASE CONNECT THE TWO UNITS 'TWIN' TERMINALS WITH 14 TO 22 AWG. WIRE.
 - FOR MOELS USING 3/4 HP & 1 HP INDOOR FAN MOTOR, USE DETAIL A & TABLE A.

Field Wiring

FIELD WIRING DIAGRAM FOR 1 STAGE FURNACE 1 STAGE HEATING USING A 1 STAGE HEATING THERMOSTAT NO COOLING

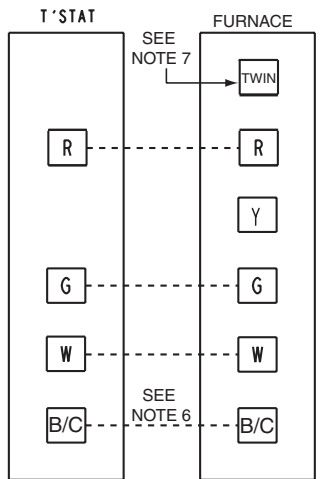

INTER-COMPONENT WIRING

----- 24 V. LINE V. } FIELD WIRING
 ----- 24 V. LINE V. } FACTORY WIRING

NOTES:

1. BE SURE POWER AGREES WITH EQUIPMENT NAMEPLATE(S).
2. LOW VOLTAGE (24V. WIRING) TO BE NO. 18 A.W.G. MIN..
3. GROUNDING OF EQUIPMENT MUST COMPLY WITH LOCAL CODES.
4. SET THERMOSTAT HEAT ANTICIPATOR PER UNIT WIRING DIAGRAM.
5. THESE LEADS PROVIDE 115 V. POWER FOR CONNECTION OF ELECTRONIC AIR CLEANER AND HUMIDIFIER MAX. LOAD 1.0 AMPS EACH.
6. THIS CONNECTION IS ONLY USED FOR THERMOSTATS REQUIRING CONNECTION TO THE 24 V. POWER SUPPLY. (COMMON)
7. SEE TWINNING CONNECTION DIAGRAMS FOR PROPER CONNECTIONS WHEN USING THIS FEATURE.

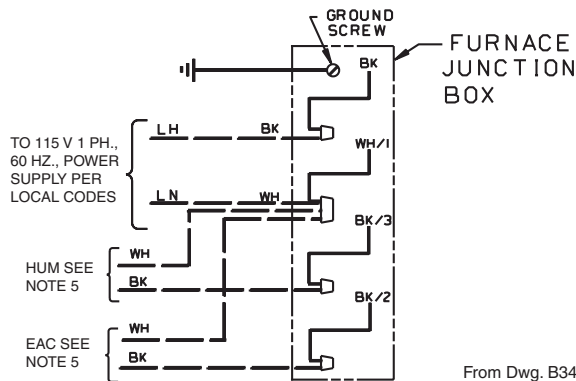

From Dwg. B341437 Rev. 1

FIELD WIRING DIAGRAM FOR 1 STAGE FURNACE 1 STAGE HEATING, 1 STAGE COOLING USING A 1 STAGE HEATING, 1 STAGE COOLING THERMOSTAT (OUTDOOR SECTION WITHOUT TRANSFORMER)

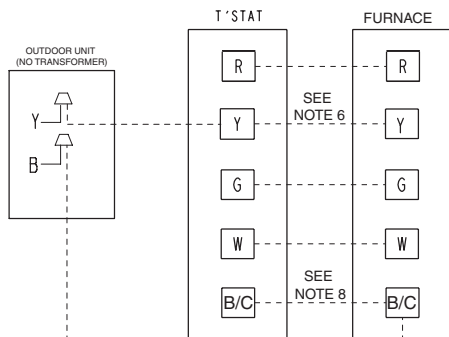

INTER-COMPONENT WIRING

----- 24 V. LINE V. } FIELD WIRING
 ----- 24 V. LINE V. } FACTORY WIRING

NOTES:

1. BE SURE POWER AGREES WITH EQUIPMENT NAMEPLATE(S)
2. LOW VOLTAGE (24 V. WIRING) TO BE NO. 18 A.W.G. MIN.
3. GROUNDING OF EQUIPMENT MUST COMPLY WITH LOCAL CODES.
4. SET THERMOSTAT HEAT ANTICIPATOR PER UNIT WIRING DIAGRAM.
5. THESE LEADS PROVIDE 115 V. POWER FOR CONNECTION OF ELECTRONIC AIR CLEANER AND HUMIDIFIER MAX. LOAD 1.0 AMPS EACH.
6. THE "Y" TERMINAL FROM THE THERMOSTAT MUST BE WIRED TO THE "Y" TERMINAL OF THE FURNACE CONTROL FOR PROPER BLOWER OPERATION DURING COOLING.
7. IGNITION CONTROL IS POLARITY SENSITIVE; HOT LEG OF 120 VOLT POWER SUPPLY MUST BE CONNECTED TO THE BLACK LINE POWER LEAD AS INDICATED ON THE WIRING DIAGRAM OR IGNITION LOCKOUT WILL OCCUR.
8. THIS CONNECTION IS ONLY USED FOR THERMOSTATS REQUIRING CONNECTION TO THE 24 V. POWER SUPPLY. (COMMON)

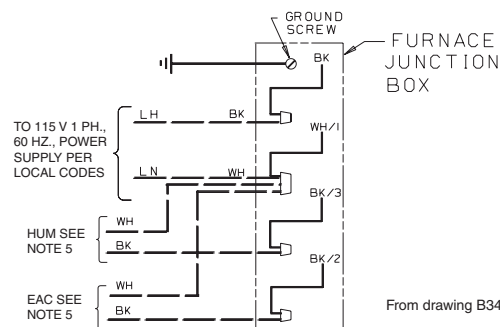

From drawing B340388 Rv 2

Twinning Field Wiring

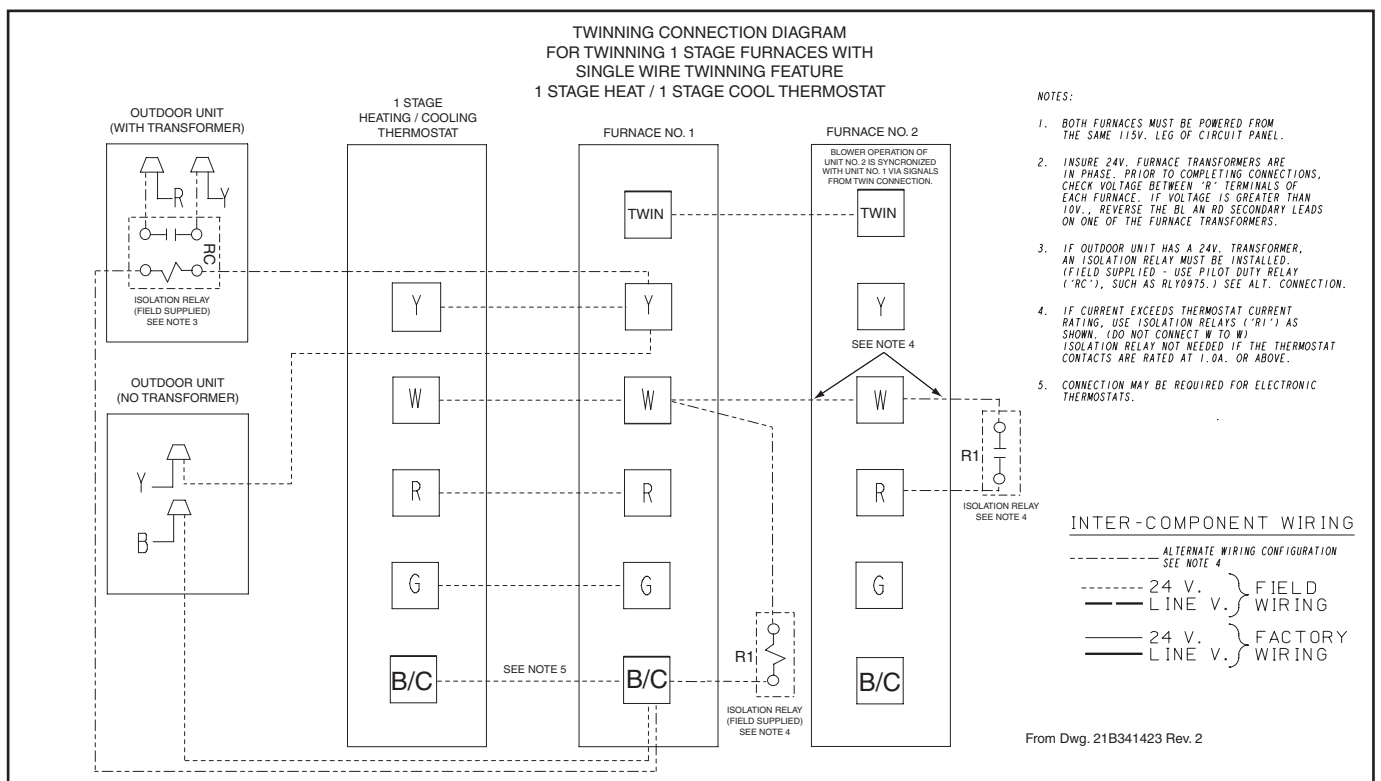
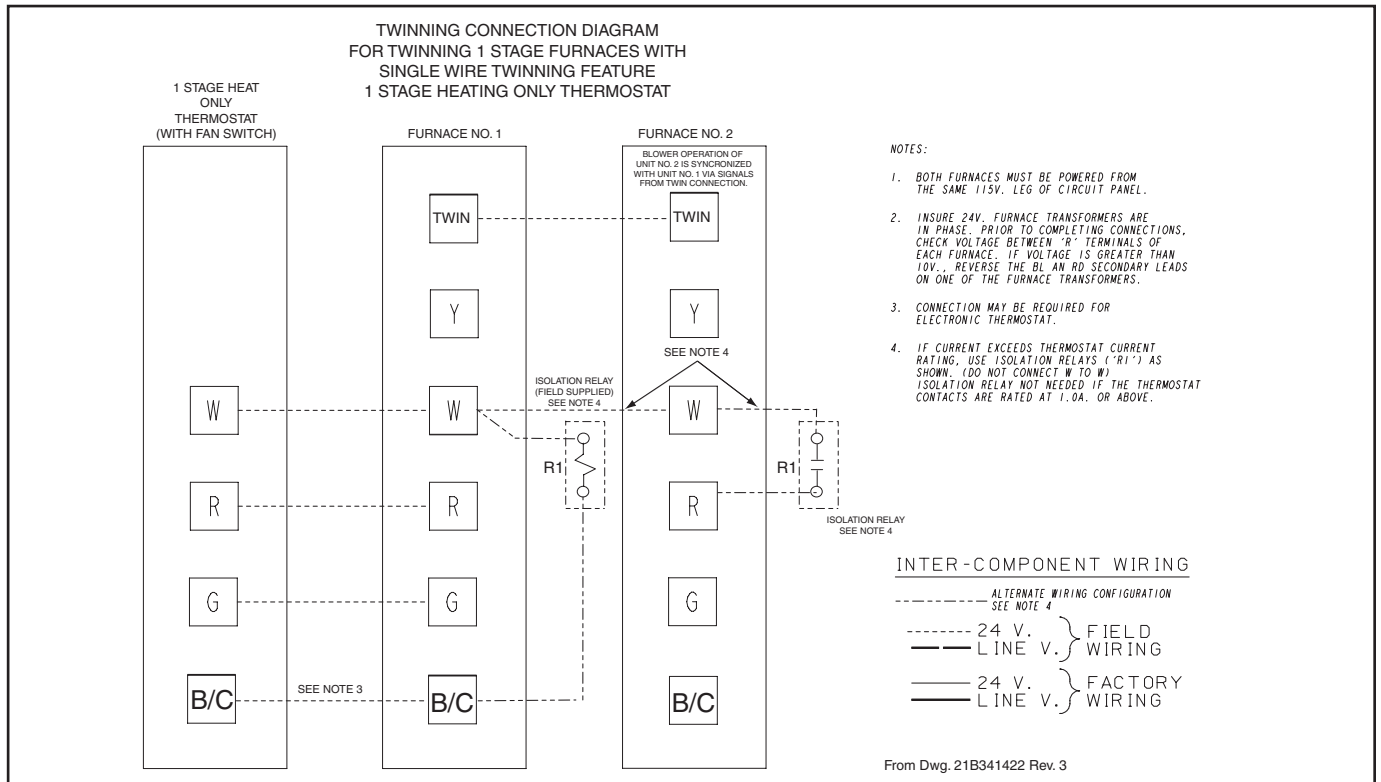

Dimensions

TDH1-H OUTLINE DRAWING (ALL DIMENSIONS ARE IN INCHES)

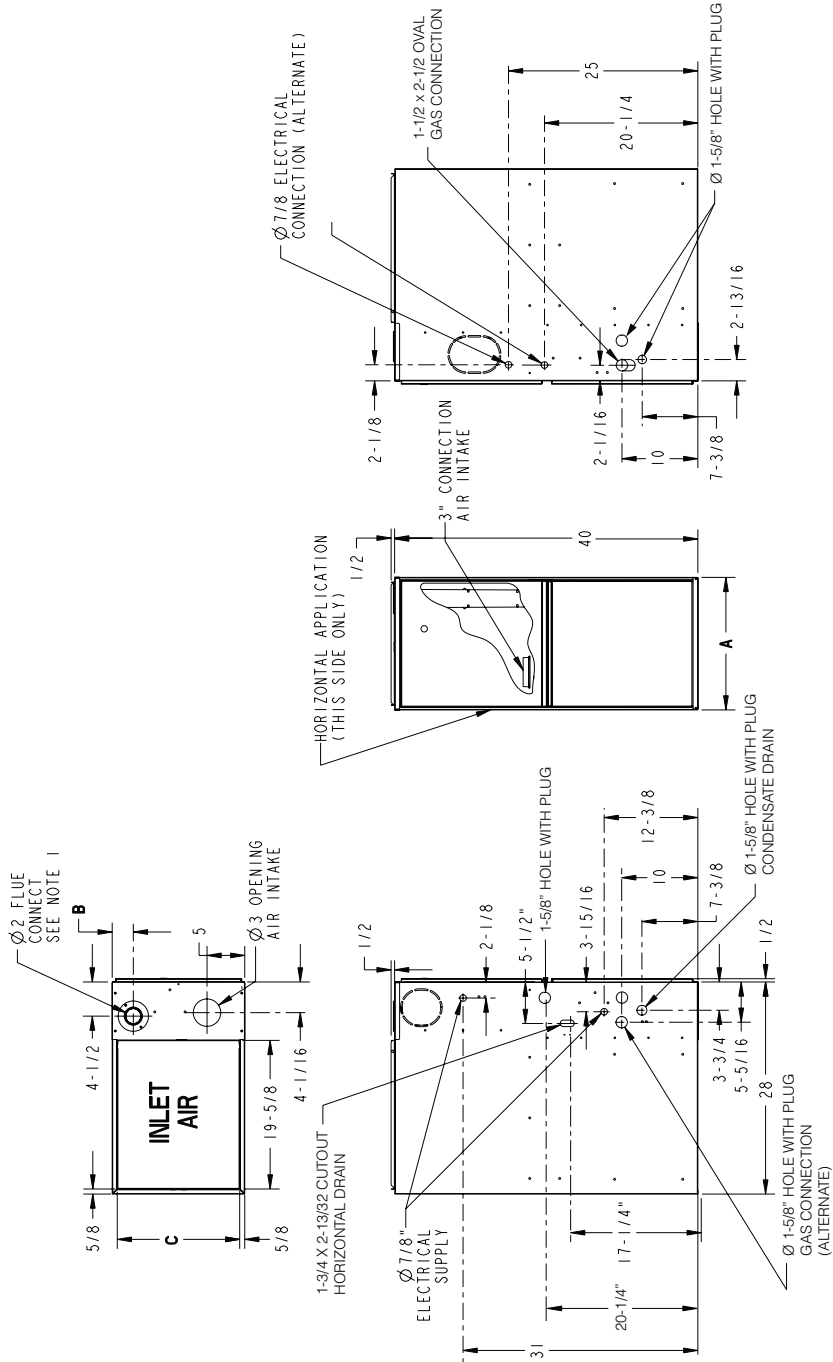

MINIMUM CLEARANCE TO COMBUSTIBLE MATERIALS	
DOWNFLOW	
SIDES	0 IN.
REAR	0 IN.
FRONT	3 IN.
FLUE	0 IN.
HORIZONTAL FLUE DISCHARGE ON THE LEFT	
SIDES	0 IN.
LEFT	0 IN.
REAR	6 IN.
FRONT	18 IN.
TOP	1 IN.
FLUE	0 IN.
CLOSED	
SIDES	1 IN.
LEFT	1 IN.
REAR	3 IN.
FRONT	3 IN.
TOP	1 IN.
FLUE	0 IN.

MODEL	DIM "A"	DIM "B"	DIM "C"	DIM "D"
*DH1B040A9H21	17-1/2"	2-1/4"	16-1/4"	16"
*DH1B065A9H31	21"	2-1/2"	19-3/4"	19-1/2"
*DH1C085A9H41	24-1/2"	2-15/16"	23-1/4"	23"

* May be "A" or "T"
Suffix may be A-Z

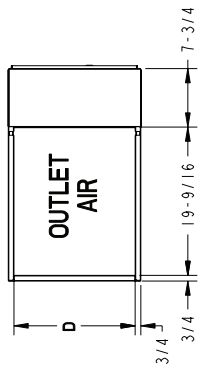



Trane
6200 Troup Highway
Tyler, TX 75707
www.trane.com

Literature Order Number	22-1859-07
File Number	22-1859-07
Supersedes	22-1859-06
Date	02/18

Trane has a policy of continuous product and product data improvement and it reserves the right to change design and specifications without notice.