



Modular Variable Speed Air Handlers

Variable Speed Communicating Air Handlers with Integrated Whole House Air Cleaner

4TEE3D01B1000A
4TEE3D02B1000A
4TEE3D03B1000A
4TEE3D04B1000A
4TEE3D05B1000A

4TEE3D06B1000A
4TEE3D07B1000A
4TEE3D08B1000A
4TEE3D09B1000A
4TEE3D10B1000A

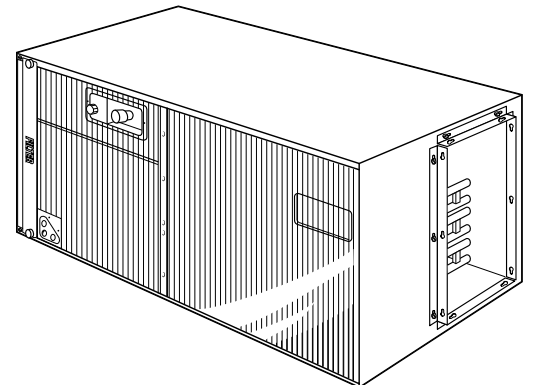
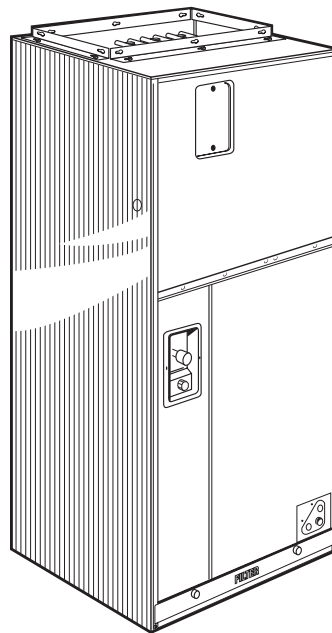

PUB. NO. 22-1820-04



Features and Benefits

- Air handler is equipped with integrated whole house air cleaner
- Ships vertical - converts to horizontal by laying unit on side.
- Six-way convertibility – horizontal (left & right), front & rear access; upflow, downflow
- Electrical, refrigerant, condensate & blower access convertible to either side
- Compact 21" depth for easy installation
- Variable speed ECM motor
- Direct drive blower
- **Comfort-R™** enhanced dehumidification cycle
- Soft Start - On cycle fan speed is increased gradually to reduce sound and drafts
- Corrosion resistant galvanized metal with attractive finish
- Non-bleed Expansion valve
- Check valve for heat pump application
- Internally enhanced finned coil tubing
- External brazed refrigerant connections
- 200/230 volt primary & 24 VAC secondary transformer
- Low voltage terminal board
- Uses 1400 & 3400 series heaters
- Access to heater circuit breakers
- Polarized plugs for making motor and transformer electrical connections from air handler control box to electric heaters
- Primary and secondary drain connections
- Easy Air-Tite™ access to coils
- Built-in indoor fan delay function for increased efficiency
- 4TEE3D01 airflow selectable for 1-1/2 — 3 ton O.D. unit
- 4TEE3D02-05 airflow selectable for 2 — 3-1/2 ton O.D. unit
- 4TEE3D06-10 airflow selectable for 3 — 5 ton O.D. unit
- Energy-saving continuous fan
- Enhanced cooling/heating control
- **ComfortLink™II** 3-wire connectivity or 24 VAC connection.

Optional Equipment

OPTIONAL EQUIPMENT FOR AIR HANDLERS (Check mark [✓] indicates accessories included).

Plenum - Pedestal (4TEE3D02, 03, 04, 06 & 08)	TAYPLNM100 []
Plenum - Pedestal (4TEE3D01)	TAYPLNM101 []
Plenum - Pedestal (4TEE3D05, 07, 09 & 10)	TAYPLNM102 []
Sub-base For Downflow (4TEE3D01)	TAYBASE101 []
Sub-base For Downflow (4TEE3D02, 03, 04, 06 & 08)	TAYBASE100 []
Sub-base For Downflow (4TEE3D05, 07, 09 & 10)	TAYBASE102 []
Evaporator Defrost Control Kit - Cooling Units (Low Ambient Cooling)	AY28X079 []
Evaporator Defrost Control Kit - Heat Pumps (Low Ambient Cooling)	AY28X084 []
Knockout cover plate (4TEE3D01-10)	BAY99X123 []
Humidistat	BAYSTAT253 []
Plenum For Upflow Non-Ducted Applications (4TEE3D01-10)	BAYPLNM120 []
Single Power Entry Kit (4TEE3D01-10)	BAYSPEK140B []



Contents

Features and Benefits	2
Optional Equipment	2
“Air-Tite™” Features and Benefits	4
General Data	5
4TEE3D01B1000A 4TEE3D06B1000A	5
4TEE3D02B1000A 4TEE3D07B1000A	5
4TEE3D03B1000A 4TEE3D08B1000A	5
4TEE3D04B1000A 4TEE3D09B1000A	5
4TEE3D05B1000A 4TEE3D10B1000A	5
Performance Data	7
Electrical Data	17
Mounting	26
Wiring Diagram	27
Field Wiring	28
Convertibility	31
Dimensions	32
Outline Drawing	33
Mechanical Specification Options	34



TRANE[®]

“Air-Tite™” Features and Benefits

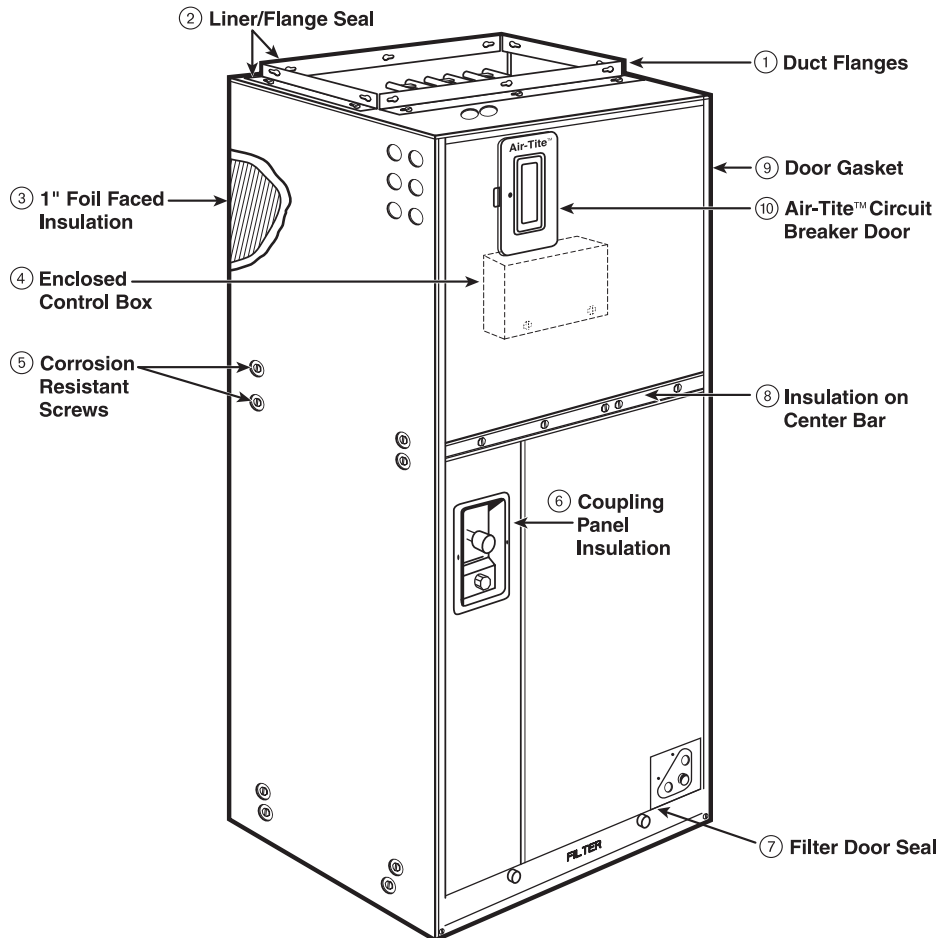

- ① **Duct Flange** – Allows flush fit for $\frac{3}{4}$ " , 1" or $1\frac{1}{2}$ " duct insulation.
- ② **Liner/Flange Seal** – Exclusive Duct Flange Thermal Break/Seal and double wall construction to reduce cabinet loss and sweating.
- ③ **1" Foil Faced Insulation** – Thicker foil faced insulation for reduced cabinet loss, sweating and lower power bills.
- ④ **Enclosed Control Box** – Totally enclosed control box with transformer inside to improve component life, unit durability and reliability.
- ⑤ **Corrosion Resistant Screws** – Exclusive “Weatherguard™” coated screws to maintain the quality appearance of the unit for the life of the product.
- ⑥ **Coupling Panel Insulation** – Exclusive “No Burn” refrigerant coupling panel with thicker insulation for reduced heat loss.
- ⑦ **Filter Door Seal** – Improved door seal for reduced air infiltration,

heat transfer, and lower power bills.

- ⑧ **Insulation on Center Bar** – Exclusive center bar insulation for reduced cabinet loss, sweating and lower power bills.
- ⑨ **Door Gasket** – Exclusive formed gasket (similar to a car door gasket) to reduce air infiltration and heat transfer and lower power bills.
- ⑩ **Air-Tite™ Circuit Breaker Door** – Easy access to breakers with positive air seal.



General Data

PRODUCT SPECIFICATIONS

MODEL	4TEE3D01B1000A	4TEE3D02B1000A	4TEE3D03B1000A	4TEE3D04B1000A	4TEE3D05B1000A
RATED VOLTS/PH/HZ.	200-230/1/60	200-230/1/60	200-230/1/60	200-230/1/60	200-230/1/60
RATINGS ①	See O.D. Specifications	See O.D. Specifications	See O.D. Specifications	See O.D. Specifications	See O.D. Specifications
INDOOR COIL — Type	Plate Fin	Plate Fin	Plate Fin	Plate Fin	Plate Fin
Rows — F.P.I.	3 — 14	3 — 14	3 — 18	3 — 18	4 — 14
Face Area (sq. ft.)	3.21	3.9	5.04	5.04	5.04
Tube Size (in.)	3/8 - Copper	3/8 - Copper	3/8 - Copper	3/8 - Copper	3/8 - Copper
Refrigerant Control	TXV - NonBleed ④	TXV - NonBleed ④	TXV - NonBleed ④	TXV - NonBleed ④	TXV - NonBleed ④
Drain Conn. Size (in.) ②	3/4 NPT	3/4 NPT	3/4 NPT	3/4 NPT	3/4 NPT
DUCT CONNECTIONS	See Outline Drawing	See Outline Drawing	See Outline Drawing	See Outline Drawing	See Outline Drawing
INDOOR FAN — Type	Centrifugal	Centrifugal	Centrifugal	Centrifugal	Centrifugal
Diameter-Width (In.)	10 x 8	10 x 10	11 x 10	11 x 10	10 x 10
No. Used	1	1	1	1	1
Drive - No. Speeds	Direct - Serial ECM	Direct - Serial ECM	Direct - Serial ECM	Direct - Serial ECM	Direct - Serial ECM
CFM vs. in. w.g.	See Fan Performance Table	See Fan Performance Table	See Fan Performance Table	See Fan Performance Table	See Fan Performance Table
No. Motors — H.P.	1 — 1/2	1 — 1/2	1 — 1/2	1 — 1/2	1 — 1/2
Motor Speed R.P.M.	Variable	Variable	Variable	Variable	Variable
Volts/Ph/Hz	200-230/1/60	200-230/1/60	200-230/1/60	200-230/1/60	200-230/1/60
F.L. Amps	4.3	4.3	4.3	4.3	4.3
FILTER					
All Applications?	Yes	Yes	Yes	Yes	Yes
Type Furnished?	Integrated Whole House Air Cleaner	Integrated Whole House Air Cleaner	Integrated Whole House Air Cleaner	Integrated Whole House Air Cleaner	Integrated Whole House Air Cleaner
Max. Indoor Relative Humidity ③	65%	65%	65%	65%	65%
REFRIGERANT	R-410A	R-410A	R-410A	R-410A	R-410A
Ref. Line Connections	Brazed	Brazed	Brazed	Brazed	Brazed
Coupling or Conn. Size — in. Gas	3/4	3/4	5/8	3/4	3/4
Coupling or Conn. Size — in. Liq.	3/8	3/8	3/8	3/8	3/8
DIMENSIONS	H x W x D	H x W x D	H x W x D	H x W x D	H x W x D
Crated (In.)	44-1/2 x 24 x 23-1/2	46-1/2 x 26 x 23-1/2	59-1/2 x 26 x 23-1/2	59-1/2 x 26 x 23-1/2	53-1/4 x 28 x 23-1/2
Uncrated	43 x 21-1/2 x 21	45 x 23-1/2 x 21	57-7/8 x 23-1/2 x 21	57-7/8 x 23-1/2 x 21	51-3/4 x 26 x 21
WEIGHT					
Shipping (Lbs.)/Net (Lbs.)	145 / 130	145 / 130	168 / 158	168 / 158	177 / 158

① These Air Handlers are A.R.I. certified with various Split System Air Conditioners and Heat Pumps (ARI STANDARD 210/240). Refer to the Split System Outdoor Unit Product Information site or ahrinet.org.

② 3/4" Male Plastic Pipe (Ref.: ASTM 1785-76)

③ See Whole House Air Cleaner section

④ Torque Spec for TXV = Tighten 1/6 turn past finger tight



TRANE®

General Data

PRODUCT SPECIFICATIONS

MODEL	4TEE3D06B1000A	4TEE3D07B1000A	4TEE3D08B1000A	4TEE3D09B1000A	4TEE3D10B1000A
RATED VOLTS/PH/HZ.	200-230/1/60	200-230/1/60	200-230/1/60	200-230/1/60	200-230/1/60
RATINGS ①	See O.D. Specifications	See O.D. Specifications	See O.D. Specifications	See O.D. Specifications	See O.D. Specifications
INDOOR COIL — Type	Plate Fin	Plate Fin	Plate Fin	Plate Fin	Plate Fin
Rows — F.P.I.	3 — 14	4 — 14	3 — 14	4 — 14	4 — 14
Face Area (sq. ft.)	6.19	6.19	6.19	7.33	7.33
Tube Size (in.)	3/8 - Copper	3/8 - Copper	3/8 - Copper	3/8 - Copper	3/8 - Copper
Refrigerant Control	TXV - NonBleed ④	TXV - NonBleed ④	TXV - NonBleed ④	TXV - NonBleed ④	TXV - NonBleed ④
Drain Conn. Size (in.) ②	3/4 NPT	3/4 NPT	3/4 NPT	3/4 NPT	3/4 NPT
DUCT CONNECTIONS	See Outline Drawing	See Outline Drawing	See Outline Drawing	See Outline Drawing	See Outline Drawing
INDOOR FAN — Type	Centrifugal	Centrifugal	Centrifugal	Centrifugal	Centrifugal
Diameter-Width (In.)	11 x 10	10 x 10	11 x 10	10 x 10	10 x 10
No. Used	1	1	1	1	1
Drive - No. Speeds	Direct - Serial ECM	Direct - Serial ECM	Direct - Serial ECM	Direct - Serial ECM	Direct - Serial ECM
CFM vs. in. w.g.	See Fan Performance Table	See Fan Performance Table	See Fan Performance Table	See Fan Performance Table	See Fan Performance Table
No. Motors — H.P.	1 — 3/4	1 — 3/4	1 — 1	1 — 1	1 — 1
Motor Speed R.P.M.	Variable	Variable	Variable	Variable	Variable
Volts/Ph/Hz	200-230/1/60	200-230/1/60	200-230/1/60	200-230/1/60	200-230/1/60
F.L. Amps	6.8	6.8	7.0	7.5	7.5
FILTER					
All Applications?	Yes	Yes	Yes	Yes	Yes
Type Furnished?	Integrated Whole House Air Cleaner	Integrated Whole House Air Cleaner	Integrated Whole House Air Cleaner	Integrated Whole House Air Cleaner	Integrated Whole House Air Cleaner
Max. Indoor Relative Humidity ③	65%	65%	65%	65%	65%
REFRIGERANT	R-410A	R-410A	R-410A	R-410A	R-410A
Ref. Line Connections	Brazed	Brazed	Brazed	Brazed	Brazed
Coupling or Conn. Size — in. Gas	3/4	3/4	3/4	3/4	3/4
Coupling or Conn. Size — in. Liq.	3/8	3/8	3/8	3/8	3/8
DIMENSIONS	H x W x D	H x W x D	H x W x D	H x W x D	H x W x D
Crated (In.)	59-1/2 x 26 x 23-1/2	59-1/2 x 28-1/2 x 23-1/2	59-1/2 x 26 x 23-1/2	63-1/4 x 28-1/2 x 23-1/2	63-1/4 x 28-1/2 x 23-1/2
Uncrated	57-7/8 x 23-1/2 x 21	57-7/8 x 26 x 21	57-7/8 x 23-1/2 x 21	62-3/4 x 26 x 21	62-3/4 x 26 x 21
WEIGHT					
Shipping (Lbs.)/Net (Lbs.)	173 / 158	191 / 176	173 / 158	221 / 199	221 / 199

① These Air Handlers are A.R.I. certified with various Split System Air Conditioners and Heat Pumps (ARI STANDARD 210/240). Refer to the Split System Outdoor Unit Product Information site or ahrinet.org.

② 3/4" Male Plastic Pipe (Ref.: ASTM 1785-76)

③ See Whole House Air Cleaner section

④ Torque Spec for TXV = Tighten 1/6 turn past finger tight



Performance Data

4TEE3D01B AIRFLOW PERFORMANCE TABLE

Airflow Performance 4TEE3D01B1: with Wet coil, No Heaters, Filter								
Outdoor Unit Size	Airflow Settings		Airflow Power	EXTERNAL STATIC PRESSURE (in.w.g.)				
	Name	CFM/ton		0.1	0.3	0.5	0.7	0.9
1.5 tons	Low	290	CFM	453	453	450	436	397
			W	40	68	95	123	146
	Med-Lo	350	CFM	578	577	572	557	524
			W	52	81	111	140	166
	Med-Hi	400	CFM	651	650	645	633	606
			W	58	89	120	152	182
	High	450	CFM	729	727	720	706	679
			W	80	112	145	179	214
2 tons	Low	290	CFM	616	616	612	597	562
			W	66	96	125	155	183
	Med-Lo	350	CFM	753	751	744	730	704
			W	86	118	152	187	222
	Med-Hi	400	CFM	849	845	837	824	805
			W	48	86	125	164	204
	High	450	CFM	939	935	928	918	905
			W	140	178	216	254	291
2.5 tons	Low	290	CFM	762	761	755	743	720
			W	98	130	164	197	229
	Med-Lo	350	CFM	914	909	900	889	874
			W	132	168	205	242	279
	Med-Hi	400	CFM	1044	1038	1028	1017	1003
			W	176	217	258	299	339
	High	450	CFM	1156	1152	1146	1137	1125
			W	228	274	319	364	407
3 tons	Low	290	CFM	900	896	888	876	860
			W	136	174	212	249	285
	Med-Lo	350	CFM	1090	1084	1074	1062	1047
			W	196	237	279	321	362
	Med-Hi	400	CFM	1225	1221	1215	1206	1195
			W	265	313	361	408	454
	High	450	CFM	1363	1363	1360	1336	1200
			W	352	408	463	502	464
NOTES:	Airflow Demand is OD size (tons) * Speed (cfm/ton) - see Demand Airflow Chart COMM SYS mode will auto-detect OD size, with default speed 400cfm/ton & 1.5 minute off-delay At continuous fan setting: Airflow values are approximately 50% of listed values With iFD filter activated, the power consumption may be slightly higher than listed values							



TRANE®

Performance Data

4TEE3D02B AIRFLOW PERFORMANCE TABLE

Airflow Performance								
4TEE3D02B1: with Wet coil, No Heaters, Filter								
Outdoor Unit Size	Airflow Settings		Airflow Power	EXTERNAL STATIC PRESSURE (in.w.g.)				
	Name	CFM/ton		0.1	0.3	0.5	0.7	0.9
2 tons	Low	290	CFM	656	602	549	497	445
			W	71	97	119	141	167
	Med-Lo	350	CFM	781	730	679	628	577
			W	97	124	151	177	206
	Med-Hi	400	CFM	887	838	790	743	696
			W	120	153	187	216	234
	High	450	CFM	984	937	892	847	802
			W	153	187	222	253	279
2.5 tons	Low	290	CFM	802	751	701	652	603
			W	104	135	160	185	211
	Med-Lo	350	CFM	957	910	865	821	778
			W	144	176	210	241	268
	Med-Hi	400	CFM	1078	1035	994	953	913
			W	202	223	258	297	333
	High	450	CFM	1199	1157	1120	1084	1049
			W	245	285	323	360	395
3 tons	Low	290	CFM	959	911	864	817	770
			W	148	178	208	240	276
	Med-Lo	350	CFM	1127	1084	1043	1004	966
			W	210	247	284	319	353
	Med-Hi	400	CFM	1266	1227	1192	1159	1126
			W	281	323	363	401	436
	High	450	CFM	1420	1382	1338	1290	1240
			W	374	422	459	488	510
3.5 tons	Low	290	CFM	1095	1052	1010	968	928
			W	195	231	269	304	336
	Med-Lo	350	CFM	1292	1251	1215	1182	1149
			W	295	337	377	415	450
	Med-Hi	400	CFM	1480	1449	1398	1329	1245
			W	397	442	473	491	498
	High	450	CFM	1576	1485	1393	1299	1205
			W	504	500	497	494	492
NOTES:	Airflow Demand is OD size (tons) * Speed (cfm/ton) - see Demand Airflow Chart COMM SYS mode will auto-detect OD size, with default speed 400cfm/ton & 1.5 minute off-delay At continuous fan setting: Airflow values are approximately 50% of listed values With iFD filter activated, the power consumption may be slightly higher than listed values							



Performance Data

4TEE3D03B, 04B AIRFLOW PERFORMANCE TABLE

Airflow Performance								
4TEE3D03B1 & 4TEE3D04B1: with Wet coil, No Heaters, Filter								
Outdoor Unit Size	Airflow Settings		Airflow Power	EXTERNAL STATIC PRESSURE (in.w.g.)				
	Name	CFM/ton		0.1	0.3	0.5	0.7	0.9
2 tons	Low	290	CFM	502	501	493	467	406
			W	39	75	112	145	166
	Med-Lo	350	CFM	647	640	619	578	511
			W	58	98	139	175	202
	Med-Hi	400	CFM	755	746	721	675	605
			W	74	119	164	203	233
High	450	CFM	861	848	819	769	698	
		W	94	141	188	231	266	
2.5 tons	Low	290	CFM	675	666	643	600	536
			W	61	104	145	181	207
	Med-Lo	350	CFM	839	828	799	751	680
			W	90	138	185	227	260
	Med-Hi	400	CFM	966	947	914	867	808
			W	116	167	217	263	304
High	450	CFM	1105	1077	1041	999	952	
		W	154	206	261	314	365	
3 tons	Low	290	CFM	834	823	794	746	675
			W	89	137	183	226	259
	Med-Lo	350	CFM	1023	1002	967	922	866
			W	130	183	234	283	327
	Med-Hi	400	CFM	1181	1149	1114	1076	1036
			W	178	232	290	346	402
High	450	CFM	1328	1293	1256	1220	1183	
		W	237	293	353	414	475	
3.5 tons	Low	290	CFM	978	958	926	884	831
			W	119	170	221	270	313
	Med-Lo	350	CFM	1206	1175	1138	1098	1055
			W	187	242	299	357	412
	Med-Hi	400	CFM	1380	1346	1309	1269	1227
			W	259	316	378	441	503
High	450	CFM	1553	1535	1487	1403	1277	
		W	354	425	482	518	528	
NOTES:	Airflow Demand is OD size (tons) * Speed (cfm/ton) - see Demand Airflow Chart COMM SYS mode will auto-detect OD size, with default speed 400cfm/ton & 1.5 minute off-delay At continuous fan setting: Airflow values are approximately 50% of listed values With iFD filter activated, the power consumption may be slightly higher than listed values							



TRANE®

Performance Data

4TEE3D05B AIRFLOW PERFORMANCE TABLE

Airflow Performance								
4TEE3D05B1: with Wet coil, No Heaters, Filter								
Outdoor Unit Size	Airflow Settings		Airflow	EXTERNAL STATIC PRESSURE (in.w.g.)				
	Name	CFM/ton	Power	0.1	0.3	0.5	0.7	0.9
2 tons	Low	290	CFM	641	641	641	641	641
			W	56	91	127	162	198
	Med-Lo	350	CFM	766	765	761	752	734
			W	79	115	153	192	231
	Med-Hi	400	CFM	865	860	850	835	814
			W	100	139	179	218	257
High	450	CFM	960	955	944	927	904	
		W	125	166	209	251	294	
2.5 tons	Low	290	CFM	788	787	782	772	752
			W	83	121	159	199	239
	Med-Lo	350	CFM	933	929	920	905	884
			W	118	158	200	243	287
	Med-Hi	400	CFM	1058	1052	1040	1023	1001
			W	153	198	243	288	333
High	450	CFM	1172	1166	1155	1139	1118	
		W	195	245	294	340	383	
3 tons	Low	290	CFM	933	929	918	900	876
			W	117	157	199	241	284
	Med-Lo	350	CFM	1101	1096	1085	1070	1049
			W	168	215	262	308	352
	Med-Hi	400	CFM	1240	1236	1226	1210	1189
			W	223	279	331	379	421
High	450	CFM	1376	1371	1361	1348	1330	
		W	289	353	411	463	508	
3.5 tons	Low	290	CFM	1070	1064	1052	1034	1010
			W	158	204	249	292	333
	Med-Lo	350	CFM	1263	1258	1247	1232	1211
			W	233	290	342	390	432
	Med-Hi	400	CFM	1421	1417	1407	1390	1366
			W	315	382	442	493	534
High	450	CFM	1584	1570	1523	1427		
		W	420	492	529	518		
NOTES:	Airflow Demand is OD size (tons) * Speed (cfm/ton) - see Demand Airflow Chart COMM SYS mode will auto-detect OD size, with default speed 400cfm/ton & 1.5 minute off-delay At continuous fan setting: Airflow values are approximately 50% of listed values With iFD filter activated, the power consumption may be slightly higher than listed values							



Performance Data

4TEE3D06B AIRFLOW PERFORMANCE TABLE

Airflow Performance								
4TEE3D06B1: with Wet coil, No Heaters, Filter								
Outdoor Unit Size	Airflow Settings		Airflow Power	EXTERNAL STATIC PRESSURE (in.w.g.)				
	Name	CFM/ton		0.1	0.3	0.5	0.7	0.9
3 tons	Low	290	CFM	955	953	942	905	813
			W	103	150	199	256	315
	Med-Lo	350	CFM	1126	1116	1096	1066	1027
			W	148	196	247	300	352
	Med-Hi	400	CFM	1270	1255	1236	1216	1193
			W	196	245	298	353	409
	High	450	CFM	1418	1401	1376	1343	1305
			W	258	311	361	408	451
3.5 tons	Low	290	CFM	1078	1070	1057	1041	1021
			W	134	181	235	293	354
	Med-Lo	350	CFM	1296	1278	1254	1228	1200
			W	206	255	307	361	414
	Med-Hi	400	CFM	1469	1456	1428	1386	1329
			W	284	339	394	446	495
	High	450	CFM	1636	1615	1592	1568	1543
			W	375	432	491	550	609
4 tons	Low	290	CFM	1233	1216	1199	1183	1166
			W	182	230	285	342	400
	Med-Lo	350	CFM	1469	1456	1428	1386	1329
			W	284	339	394	446	495
	Med-Hi	400	CFM	1666	1646	1608	1553	1481
			W	391	448	500	546	583
	High	450	CFM	1817	1803	1764	1694	1587
			W	494	561	614	646	655
5 tons	Low	290	CFM	1502	1486	1457	1417	1366
			W	301	354	407	457	504
	Med-Lo	350	CFM	1817	1803	1764	1694	1587
			W	494	561	614	646	655
	Med-Hi	400	CFM	2069	2015	1882	1656	
			W	711	751	719	620	
	High	450	CFM	2110	2013	1916	1819	1722
			W	749	747	745	743	742
NOTES:	Airflow Demand is OD size (tons) * Speed (cfm/ton) - see Demand Airflow Chart COMM SYS mode will auto-detect OD size, with default speed 400cfm/ton & 1.5 minute off-delay At continuous fan setting: Airflow values are approximately 50% of listed values With iFD filter activated, the power consumption may be slightly higher than listed values							



TRANE®

Performance Data

4TEE3D07B AIRFLOW PERFORMANCE TABLE

Airflow Performance 4TEE3D07B1: with Wet coil, No Heaters, Filter								
Outdoor Unit Size	Airflow Settings		Airflow Power	EXTERNAL STATIC PRESSURE (in.w.g.)				
	Name	CFM/ton		0.1	0.3	0.5	0.7	0.9
3 tons	Low	290	CFM	869	869	869	869	869
			W	102	146	190	232	273
	Med-Lo	350	CFM	1043	1043	1043	1043	1043
			W	144	192	240	288	336
	Med-Hi	400	CFM	1189	1189	1189	1189	1189
			W	192	245	297	351	405
	High	450	CFM	1331	1331	1331	1331	1331
			W	249	308	365	421	476
3.5 tons	Low	290	CFM	1009	1009	1009	1009	1009
			W	136	183	230	277	324
	Med-Lo	350	CFM	1210	1210	1210	1210	1210
			W	201	255	308	360	413
	Med-Hi	400	CFM	1379	1379	1379	1379	1379
			W	271	332	391	449	506
	High	450	CFM	1546	1545	1545	1544	1544
			W	365	428	492	556	621
4 tons	Low	290	CFM	1219	1219	1219	1219	1219
			W	210	264	318	371	423
	Med-Lo	350	CFM	1380	1380	1380	1380	1380
			W	273	335	395	454	512
	Med-Hi	400	CFM	1569	1569	1569	1569	1569
			W	374	447	512	574	633
	High	450	CFM	1754	1754	1754	1754	1754
			W	510	584	652	717	781
5 tons	Low	290	CFM	1418	1418	1418	1418	1418
			W	299	362	422	482	541
	Med-Lo	350	CFM	1714	1713	1713	1713	1713
			W	468	549	620	687	749
	Med-Hi	400	CFM	1945	1910	1846	1755	1638
			W	660	723	743	725	675
	High	450	CFM	2016	1917	1832	1754	1680
			W	734	730	726	724	721
NOTES:	Airflow Demand is OD size (tons) * Speed (cfm/ton) - see Demand Airflow Chart COMM SYS mode will auto-detect OD size, with default speed 400cfm/ton & 1.5 minute off-delay At continuous fan setting: Airflow values are approximately 50% of listed values With iFD filter activated, the power consumption may be slightly higher than listed values							



Performance Data

4TEE3D08B AIRFLOW PERFORMANCE TABLE

Airflow Performance 4TEE3D08B1: with Wet coil, No Heaters, Filter								
Outdoor Unit Size	Airflow Settings		Airflow Power	EXTERNAL STATIC PRESSURE (in.w.g.)				
	Name	CFM/ton		0.1	0.3	0.5	0.7	0.9
3 tons	Low	290	CFM	934	926	907	876	833
			W	99	147	196	242	283
	Med-Lo	350	CFM	1030	1007	997	990	985
			W	146	194	241	287	332
	Med-Hi	400	CFM	1195	1188	1172	1143	1101
			W	199	249	300	348	393
High	450	CFM	1363	1355	1341	1320	1295	
		W	266	320	373	425	473	
3.5 tons	Low	290	CFM	1083	1063	1035	1001	963
			W	132	180	231	283	334
	Med-Lo	350	CFM	1227	1220	1202	1173	1131
			W	211	262	313	362	407
	Med-Hi	400	CFM	1409	1404	1392	1372	1342
			W	289	344	399	454	506
High	450	CFM	1576	1569	1555	1537	1514	
		W	382	442	502	560	618	
4 tons	Low	290	CFM	1233	1213	1184	1148	1107
			W	174	223	277	334	391
	Med-Lo	350	CFM	1409	1404	1392	1372	1342
			W	289	344	399	454	506
	Med-Hi	400	CFM	1606	1596	1581	1560	1535
			W	400	460	518	574	629
High	450	CFM	1813	1803	1792	1782	1772	
		W	551	618	686	756	825	
5 tons	Low	290	CFM	1533	1506	1474	1438	1399
			W	291	340	398	459	522
	Med-Lo	350	CFM	1750	1739	1728	1716	1704
			W	502	567	634	701	768
	Med-Hi	400	CFM	1995	1987	1974	1953	1926
			W	719	794	865	932	993
High	450	CFM	2177	2133	2068	1987	1892	
		W	932	969	981	974	952	
NOTES:	Airflow Demand is OD size (tons) * Speed (cfm/ton) - see Demand Airflow Chart COMM SYS mode will auto-detect OD size, with default speed 400cfm/ton & 1.5 minute off-delay At continuous fan setting: Airflow values are approximately 50% of listed values With iFD filter activated, the power consumption may be slightly higher than listed values							



TRANE®

Performance Data

4TEE3D09B, 10B AIRFLOW PERFORMANCE TABLE

Airflow Performance								
4TEE3D09B1 & 4TEE3D10B1: with Wet coil, No Heaters, Filter								
Outdoor Unit Size	Airflow Settings		Airflow	EXTERNAL STATIC PRESSURE (in.w.g.)				
	Name	CFM/ton	Power	0.1	0.3	0.5	0.7	0.9
3 tons	Low	290	CFM	806	806	806	806	806
			W	87	128	168	209	249
	Med-Lo	350	CFM	993	993	993	993	993
			W	124	172	221	269	318
	Med-Hi	400	CFM	1157	1157	1157	1157	1157
			W	170	225	281	335	388
	High	450	CFM	1332	1332	1332	1332	1332
			W	233	296	359	422	485
3.5 tons	Low	290	CFM	956	956	956	956	956
			W	116	163	209	256	302
	Med-Lo	350	CFM	1186	1186	1186	1186	1186
			W	178	234	290	345	401
	Med-Hi	400	CFM	1398	1398	1398	1398	1398
			W	261	327	394	460	527
	High	450	CFM	1618	1618	1618	1618	1618
			W	372	455	535	609	672
4 tons	Low	290	CFM	1112	1112	1112	1112	1112
			W	158	211	264	317	370
	Med-Lo	350	CFM	1397	1397	1397	1397	1397
			W	259	326	393	459	526
	Med-Hi	400	CFM	1650	1650	1650	1650	1650
			W	388	475	559	636	701
	High	450	CFM	1893	1893	1893	1893	1893
			W	578	688	769	821	844
5 tons	Low	290	CFM	1454	1454	1454	1454	1454
			W	288	358	428	498	568
	Med-Lo	350	CFM	1838	1838	1838	1838	1838
			W	526	630	716	778	808
	Med-Hi	400	CFM	2135	2116	2067	1979	1846
			W	817	894	926	903	825
	High	450	CFM	2216	2128	2048	1972	1899
			W	911	905	901	898	896
NOTES:	Airflow Demand is OD size (tons) * Speed (cfm/ton) - see Demand Airflow Chart COMM SYS mode will auto-detect OD size, with default speed 400cfm/ton & 1.5 minute off-delay At continuous fan setting: Airflow values are approximately 50% of listed values With ifD filter activated, the power consumption may be slightly higher than listed values							



Electrical Data

	VOLT	MTR AMPS	HEATER AMPS	MCA	MOP	MIN BLOWER SPEED		CAPACITY	
						WITH OUT HEAT PUMP	WITH HEAT PUMP	KW	TOTAL BTUH
4TEE3C01 / 4TEE3D01 (no heater)		4.30		5	15				
BAYHTR1405***	208	4.30	17.3	27	30	1000	1130	3.60	12300
	240		20.0	30	30			4.80	16400
BAYHTR1408***	208		27.7	40	40	1000 +	1130	5.76	19700
	240		32.0	45	45			7.68	26200
BAYHTR1410***	208		34.6	49	50	1130	1350	7.20	24600
	240		40.0	55	60			9.60	32800
BAYHTR1415BRK circuit 1 circuit 2	208		34.6	49	50	1130	1350	7.20	39300
	240		40.0	55	60			9.60	52400
	208		20.8	26	30			4.33	
	240		24.0	30	30			5.76	
BAYHTR1415BRK with single circuit power source kit BAYSPEK140B	208		55.4	75	80	1130	1350	11.5	39300
	240		64.0	85	90			15.4	52400
BAYHTR3410***	208		30.0	37	40	1130	1350	7.20	24600
	240		34.6	43	45			9.60	32800
BAYHTR3415***	208		33.1	46	50	1130	1350	11.53	39300
	240		38.2	52	60			15.36	52400
BAYHTR1419BRK circuit 1 circuit 2	208		27.7	40	40	1130	1350	5.76	49200
	240		32.0	45	45			7.68	65500
	208		41.6	52	60			8.66	
	240		48.0	60	60			11.52	
BAYHTR1419BRK with single circuit power source kit BAYSPEK140B	208	69.3	92	100	1130	1350	14.4	49200	
	240	80.0	105	110			19.2	65500	

NOTES:

(+) For Upflow position without heat pump, minimum setting is 1130.

(***) = additional suffix digits 000, BRK or PDC - 000 = pigtails, BRK = contains circuit breakers & PDC = contains pull disconnect.

IMPORTANT: Any power supply and / or combination power supply, circuit or circuits must be wired and protected in accordance with local Electrical codes.



TRANE®

Electrical Data

						MIN BLOWER SPEED		CAPACITY	
	VOLT	MTR AMPS	HEATER AMPS	MCA	MOP	WITH OUT HEAT PUMP	WITH HEAT PUMP	KW	TOTAL BTUH
4TEE3C02 / 4TEE3D02 (no heater)		4.30		5	15				
BAYHTR1405***	208	4.30	17.3	27	30	600	900	3.60	12300
	240		20.0	30	30			4.80	16400
BAYHTR1408***	208		27.7	40	40	900	1100	5.76	19700
	240		32.0	45	45			7.68	26200
BAYHTR1410***	208		34.6	49	50	1100	1450	7.20	24600
	240		40.0	55	60			9.60	32800
circuit 1 BAYHTR1415BRK circuit 2	208		34.6	49	50	1100	1450	7.20	39300
	240		40.0	55	60			9.60	52400
	208		20.8	26	30			4.33	
	240		24.0	30	30			5.76	
BAYHTR1415BRK with single circuit power source kit BAYSPEK140B	208		55.4	75	80	1100	1450	11.5	39300
	240		64.0	85	90			15.4	52400
BAYHTR3410***	208		30.0	37	40	1100	1450	7.20	24600
	240		34.6	43	45			9.60	32800
BAYHTR3415***	208		33.1	46	50	1100	1450	11.53	39300
	240		38.2	52	60			15.36	52400
circuit 1 BAYHTR1419BRK circuit 2	208	27.7	40	40	1100	1450	5.76	49200	
	240	32.0	45	45			7.68	65500	
	208	41.6	52	60			8.66		
	240	48.0	60	60			11.52		
BAYHTR1419BRK with single circuit power source kit BAYSPEK140B	208	69.3	92	100	1100	1450	14.4	49200	
	240	80.0	105	110			19.2	65500	

NOTES:

(***) = additional suffix digits 000, BRK or PDC - 000 = pigtails, BRK = contains circuit breakers & PDC = contains pull disconnect.

IMPORTANT: Any power supply and / or combination power supply, circuit or circuits must be wired and protected in accordance with local Electrical codes.



Electrical Data

	VOLT	MTR AMPS	HEATER AMPS	MCA	MOP	MIN BLOWER SPEED		CAPACITY	
						WITH OUT HEAT PUMP	WITH HEAT PUMP	KW	TOTAL BTUH
4TEE3C03 / 4TEE3D03 (no heater) 4TEE3C04 / 4TEE3D04 (no heater)		4.30		5	15				
BAYHTR1405***	208	4.30	17.3	27	30	900 (1)	900	3.60	12300
	240		20.0	30	30			4.80	16400
BAYHTR1408***	208		27.7	40	40	900 (2)	900	5.76	19700
	240		32.0	45	45			7.68	26200
BAYHTR1410***	208		34.6	49	50	900	1100	7.20	24600
	240		40.0	55	60			9.60	32800
circuit 1 BAYHTR1415BRK circuit 2	208		34.6	49	50	900 (3)	1100	7.20	39300
	240		40.0	55	60			9.60	52400
	208		20.8	26	30			4.33	
	240		24.0	30	30			5.76	
BAYHTR1415BRK with single circuit power source kit BAYSPEK140B	208		55.4	79	80	900 (3)	1100	11.5	39300
	240		64.0	89	90			15.4	52400
BAYHTR3410***	208		30.0	37	40	900	1100	7.20	24600
	240		34.6	43	45			9.60	32800
BAYHTR3415***	208		33.1	46	50	900 (3)	1100	11.53	39300
	240		38.2	52	60			15.36	52400
circuit 1 BAYHTR1419BRK circuit 2	208		27.7	40	40	900 (4)	1100 (3)	5.76	49200
	240		32.0	45	45			7.68	65500
	208		41.6	52	60			8.66	
	240		48.0	60	60			11.52	
BAYHTR1419BRK with single circuit power source kit BAYSPEK140B	208	69.3	96	100	900 (4)	1100 (3)	14.4	49200	
	240	80.0	109	110			19.2	65500	

NOTES:

- (1) Minimum speed in downflow and horizontal right installations is 600 CFM.
- (2) Minimum speed in upflow and horizontal right installations is 600 CFM.
- (3) Minimum speed in downflow installations is 1400 CFM.
- (4) Minimum speed in downflow installations is 1100 CFM.

(***) = additional suffix digits 000, BRK or PDC - 000 = pigtails, BRK = contains circuit breakers & PDC = contains pull disconnect.

IMPORTANT: Any power supply and / or combination power supply, circuit or circuits must be wired and protected in accordance with local Electrical codes.



TRANE®

Electrical Data

						MIN BLOWER SPEED		CAPACITY	
	VOLT	MTR AMPS	HEATER AMPS	MCA	MOP	WITH OUT HEAT PUMP	WITH HEAT PUMP	KW	TOTAL BTUH
4TEE3C05 / 4TEE3D05 (no heater)		4.30		5	15				
BAYHTR1405***	208	4.30	17.3	27	30	600	900 +	3.60	12300
	240		20.0	30	30			4.80	16400
BAYHTR1408***	208		27.7	40	40	600	900	5.76	19700
	240		32.0	45	45			7.68	26200
BAYHTR1410***	208		34.6	49	50	900	1100	7.20	24600
	240		40.0	55	60			9.60	32800
circuit 1 BAYHTR1415BRK	208		34.6	49	50	1100	1400	7.20	39300
	240		40.0	55	60			9.60	52400
circuit 2	208		20.8	26	30	1100	1400	4.33	
	240		24.0	30	30			5.76	
BAYHTR1415BRK with single circuit power source kit	208		55.4	75	80	1100	1400	11.5	39300
	240		64.0	85	90			15.4	52400
BAYSPEK140B	208		30.0	37	40	900	1100	7.20	24600
	240		34.6	43	45			9.60	32800
BAYHTR3410***	208		33.1	46	50	1100	1400	11.53	39300
	240		38.2	52	60			15.36	52400
BAYHTR3415***	208		27.7	40	40	1100	1400	5.76	49200
	240		32.0	45	45			7.68	65500
circuit 1 BAYHTR1419BRK	208		41.6	52	60	1100	1400	8.66	
	240		48.0	60	60			11.52	
circuit 2	208	69.3	92	100	1100	1400	14.4	49200	
	240	80.0	105	110			19.2	65500	
BAYHTR1419BRK with single circuit power source kit	208	38.1	48	50	1100	1400	7.93	63900	
	240	44.0	55	60			10.56	85200	
BAYSPEK140B	208	34.6	49	50	1100	1400	7.20		
	240	40.0	55	60			9.60		
circuit 1 BAYHTR1425BRK	208	17.3	22	25	1100	1400	3.60		
	240	20.0	25	25			4.80		
circuit 2	208				1100	1400			
	240								
circuit 3	208				1100	1400			
	240								

NOTES:

(+) For horizontal right and downflow position, minimum speed for heat pump applications is 1100 CFM

(***) = additional suffix digits 000, BRK or PDC - 000 = pigtails, BRK = contains circuit breakers & PDC = contains pull disconnect.

IMPORTANT: Any power supply and / or combination power supply, circuit or circuits must be wired and protected in accordance with local Electrical codes.



Electrical Data

	VOLT	MTR AMPS	HEATER AMPS	MCA	MOP	MIN BLOWER SPEED		CAPACITY	
						WITH OUT HEAT PUMP	WITH HEAT PUMP	KW	TOTAL BTUH
4TEE3C06 / 4TEE3D06 (no heater)		6.80		9	15				
BAYHTR1405***	208		17.3	30	30	800	800	3.60	12300
	240		20.0	34	35			4.80	16400
BAYHTR1408***	208		27.7	43	45	800	1100 (1)	5.76	19700
	240		32.0	49	50			7.68	26200
BAYHTR1410***	208		34.6	52	60	800	1100 (2)	7.20	24600
	240		40.0	59	60			9.60	32800
circuit 1 BAYHTR1415BRK circuit 2	208		34.6	52	60	800	1100 (3)	7.20	39300
	240		40.0	59	60			9.60	52400
	208		20.8	26	30			4.33	
BAYHTR1415BRK with single circuit power source kit BAYSPEK140B	208		55.4	78	80	800	1100 (3)	11.5	39300
	240		64.0	89	90			15.4	52400
BAYHTR3410***	208		30.0	37	40	800	1100 (2)	7.20	24600
	240		34.6	43	45			9.60	32800
BAYHTR3415***	208		33.1	49	50	800	1100 (3)	11.53	39300
	240		38.2	55	60			15.36	52400
circuit 1 BAYHTR1419BRK circuit 2	208		27.7	43	45	800	1100 (4)	5.76	49200
	240		32.0	49	50			7.68	65500
	208		41.6	52	60			8.66	
	240		48.0	60	60			11.52	
BAYHTR1419BRK with single circuit power source kit BAYSPEK140B	208		69.3	95	100	800	1100 (4)	14.4	49200
	240		80.0	109	110			19.2	65500
circuit 1 BAYHTR1425BRK circuit 2 circuit 3	208		38.1	48	50	800(5)	1400 (6)	7.93	63900
	240		44.0	55	60			10.56	85200
	208		34.6	52	60			7.20	
	240		40	59	60			9.60	
	208		17.3	22	25			3.60	
	240		20	25	25			4.80	

NOTES:

- (1) Minimum speed for horizontal left installations is 1400 CFM; in horizontal right installations is 800 CFM.
 - (2) Minimum speed for horizontal right installations is 800 CFM.
 - (3) Minimum speed in downflow installations is 1400 CFM.
 - (4) Minimum speed in downflow and upflow installations is 1400 CFM.
 - (5) Minimum speed in horizontal left and downflow installations is 1100 CFM.
 - (6) Minimum speed in horizontal left installations is 1100 CFM.
 - (***) = additional suffix digits 000, BRK or PDC - 000 = pigtails, BRK = contains circuit breakers & PDC = contains pull disconnect.
- IMPORTANT:** Any power supply and / or combination power supply, circuit or circuits must be wired and protected in accordance with local Electrical codes.



TRANE®

Electrical Data

						MIN BLOWER SPEED		CAPACITY	
	VOLT	MTR AMPS	HEATER AMPS	MCA	MOP	WITH OUT HEAT PUMP	WITH HEAT PUMP	KW	TOTAL BTUH
4TEE3C07 / 4TEE3D07 (no heater)		6.80		9	15				
BAYHTR1405***	208	6.80	17.3	30	30	800	1100	3.60	12300
	240		20.0	34	35			4.80	16400
BAYHTR1408***	208		27.7	43	45	800	1100	5.76	19700
	240		32.0	49	50			7.68	26200
BAYHTR1410***	208		34.6	52	60	800	1400	7.20	24600
	240		40.0	59	60			9.60	32800
BAYHTR1415BRK circuit 1 circuit 2	208		34.6	52	60	1100	1700	7.20	39300
	240		40.0	59	60			9.60	52400
	208		20.8	26	30			4.33	
	240		24.0	30	30			5.76	
BAYHTR1415BRK with single circuit power source kit BAYSPEK140B	208		55.4	78	80	1100	1700	11.5	39300
	240		64.0	89	90			15.4	52400
BAYHTR3410***	208		30.0	37	40	800	1400	7.20	24600
	240		34.6	43	45			9.60	32800
BAYHTR3415***	208	33.1	49	50	1100	1700	11.53	39300	
	240	38.2	55	60			15.36	52400	
BAYHTR1419BRK circuit 1 circuit 2	208	27.7	43	45	1400	1700	5.76	49200	
	240	32.0	49	50			7.68	65500	
	208	41.6	52	60			8.66		
	240	48.0	60	60			11.52		
BAYHTR1419BRK with single circuit power source kit BAYSPEK140B	208	69.3	95	100	1400	1700	14.4	49200	
	240	80.0	109	110			19.2	65500	
BAYHTR1425BRK circuit 1 circuit 2 circuit 3	208	38.1	48	50	1400	1700	7.93	63900	
	240	44.0	55	60			10.56	85200	
	208	34.6	52	60			7.20		
	240	40.0	59	60			9.60		
	208	17.3	22	25			3.60		
	240	20.0	25	25			4.80		

NOTES:

(***) = additional suffix digits 000, BRK or PDC - 000 = pigtails, BRK = contains circuit breakers & PDC = contains pull disconnect.

IMPORTANT: Any power supply and / or combination power supply, circuit or circuits must be wired and protected in accordance with local Electrical codes.



Electrical Data

						MIN BLOWER SPEED		CAPACITY	
	VOLT	MTR AMPS	HEATER AMPS	MCA	MOP	WITH OUT HEAT PUMP	WITH HEAT PUMP	KW	TOTAL BTUH
4TEE3C08 / 4TEE3D08 (no heater)		7.50		9	15				
BAYHTR1405***	208		17.3	31	35	900	900	3.60	12300
	240		20.0	34	35			4.80	16400
BAYHTR1408***	208		27.7	44	45	900	900 (1)	5.76	19700
	240		32.0	49	50			7.68	26200
BAYHTR1410***	208		34.6	53	60	900	1200 (2)	7.20	24600
	240		40.0	59	60			9.60	32800
circuit 1 BAYHTR1415BRK circuit 2	208		34.6	53	60	900 (1)	1200	7.20	39300
	240		40.0	59	60			9.60	52400
	208		20.8	26	30			4.33	
	240		24.0	30	30			5.76	
BAYHTR1415BRK with single circuit power source kit BAYSPEK140B	208		55.4	79	80	900 (1)	1200	11.5	39300
	240		64.0	89	90			15.4	52400
BAYHTR3410***	208		30.0	37	40	900	1200 (2)	7.20	24600
	240		34.6	43	45			9.60	32800
BAYHTR3415***	208		33.1	49	50	900 (1)	1200	11.53	39300
	240		38.2	56	60			15.36	52400
circuit 1 BAYHTR1419BRK circuit 2	208		27.7	44	45	900	1200 (3)	5.76	49200
	240		32.0	49	50			7.68	65500
	208		41.6	52	60			8.66	
	240		48.0	60	60			11.52	
BAYHTR1419BRK with single circuit power source kit BAYSPEK140B	208		69.3	96	100	900	1200 (3)	14.4	49200
	240		80.0	109	110			19.2	65500
circuit 1 BAYHTR1425BRK circuit 2 circuit 3	208		38.1	48	50	Note (4)	1500 (5)	7.93	63900
	240		44.0	55	60			10.56	85200
	208		34.6	53	60			7.2	
	240		40	59	60			9.6	
	208		17.3	22	25			3.6	
	240		20	25	25			4.8	

NOTES:

- (1) Minimum speed in downflow installations is 1200 CFM.
 - (2) Minimum speed in upflow installations is 900 CFM.
 - (3) Minimum speed in upflow installations is 1500 CFM.
 - (4) Minimum speed in horizontal left installations is 1500 CFM; in horizontal right installations is 900 CFM; in downflow installations is 1200 CFM. Minimum speed for upflow installations on 240 volts is 1800 CFM. Heater not approved for upflow installations on 208 volts.
 - (5) Minimum speed in horizontal left installations is 1800 CFM.
- (***) = additional suffix digits 000, BRK or PDC - 000 = pigtails, BRK = contains circuit breakers & PDC = contains pull disconnect.
- IMPORTANT:** Any power supply and / or combination power supply, circuit or circuits must be wired and protected in accordance with local Electrical codes.



TRANE®

Electrical Data

						MIN BLOWER SPEED		CAPACITY	
	VOLT	MTR AMPS	HEATER AMPS	MCA	MOP	WITH OUT HEAT PUMP	WITH HEAT PUMP	KW	TOTAL BTUH
4TEE3C09 / 4TEE3D09 (no heater) 4TEE3C10 / 4TEE3D10 (no heater)		7.50		9	15				
BAYHTR1405***	208		17.3	31	35	900	1200	3.60	12300
	240		20.0	34	35			4.80	16400
BAYHTR1408***	208		27.7	44	45	900	1200	5.76	19700
	240		32.0	49	50			7.68	26200
BAYHTR1410***	208		34.6	53	60	1200	1500	7.20	24600
	240		40.0	59	60			9.60	32800
circuit 1 BAYHTR1415BRK circuit 2	208		34.6	53	60	1200 +	1500 +	7.20	39300
	240		40.0	59	60			9.60	52400
	208		20.8	26	30			4.33	
	240		24.0	30	30			5.76	
BAYHTR1415BRK with single circuit power source kit BAYSPEK140B	208		55.4	79	80	1200 +	1500 +	11.5	39300
	240		64.0	89	90			15.4	52400
BAYHTR3410***	208		30.0	37	40	1200	1500	7.20	24600
	240		34.6	43	45			9.60	32800
BAYHTR3415***	208		33.1	49	50	1200 +	1500 +	11.53	39300
	240		38.2	56	60			15.36	52400
circuit 1 BAYHTR1419BRK circuit 2	208		27.7	44	45	1200	1500	5.76	49200
	240		32.0	49	50			7.68	65500
	208		41.6	52	60			8.66	
	240		48.0	60	60			11.52	
BAYHTR1419BRK with single circuit power source kit BAYSPEK140B	208	69.3	96	100	1200	1500	14.4	49200	
	240	80.0	109	110			19.2	65500	
circuit 1 BAYHTR1425BRK circuit 2 circuit 3	208	38.1	48	50	1500	1800	7.93	63900	
	240	44.0	55	60			10.56	85200	
	208	34.6	53	60			7.20		
	240	40.0	59	60			9.60		
	208	17.3	22	25			3.60		
	240	20.0	25	25			4.80		

NOTES:

(+) For upflow applications only, minimum speed is 1500 with out heat pump and 1800 with heat pump.

(***) = additional suffix digits 000, BRK or PDC - 000 = pigtailed, BRK = contains circuit breakers & PDC = contains pull disconnect.

IMPORTANT: Any power supply and / or combination power supply, circuit or circuits must be wired and protected in accordance with local Electrical codes.

Performance Data

DISTANCE FROM BELLY BAND TO SHAFT FACE OF MOTOR FOR MINIMUM VIBRATION

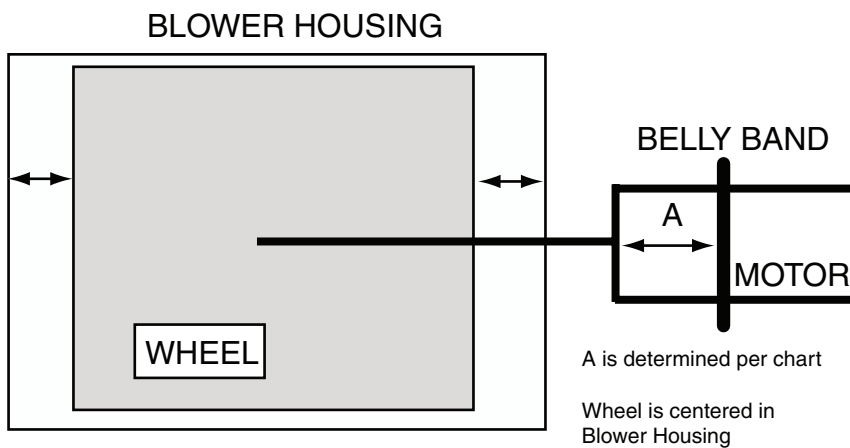

A is determined per chart

Wheel is centered in
Blower Housing

Model Number	"A" (inches)
4TEE3C01	1.375
4TEE3C02	1.375
4TEE3C03	1.375
4TEE3C04	1.375
4TEE3C05	1.875
4TEE3C06	2.125
4TEE3C07	2.125
4TEE3C08	2.125
4TEE3C09	2.250
4TEE3C10	2.250
FOR FACTORY OEM MOTORS	



Mounting

AIR HANDLER SUBBASE

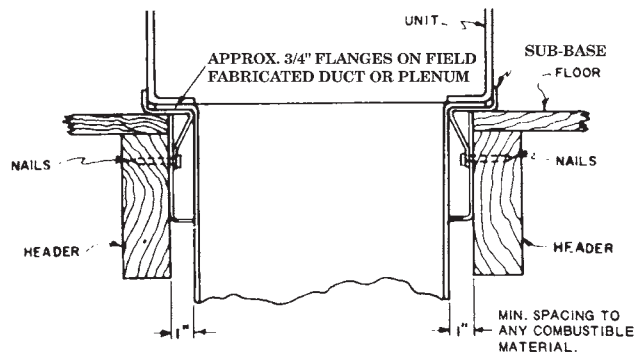
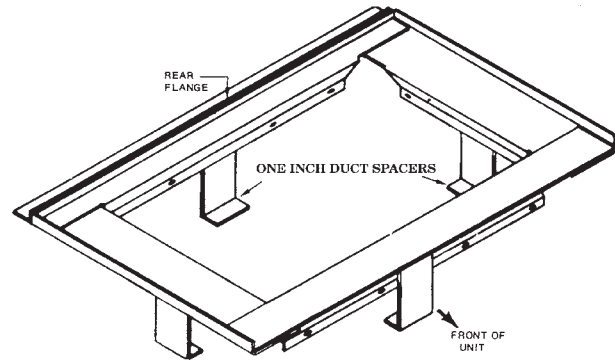
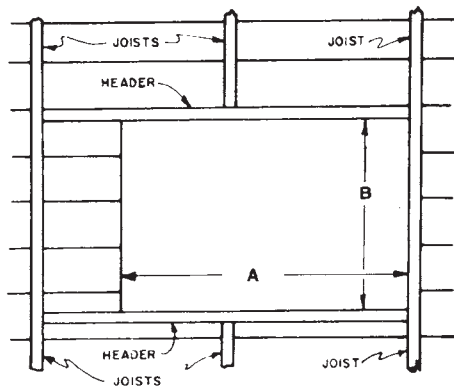

FLOOR OPENING - SIZE		
MODEL NO.	A	B
TAYBASE100	23-3/4	14-13/16
TAYBASE101	21-3/4	14-13/16
TAYBASE102	26-3/4	14-13/16

Wiring Diagram

WIRING DIAGRAM FOR COMMUNICATING VARIABLE SPEED AIR HANDLERS

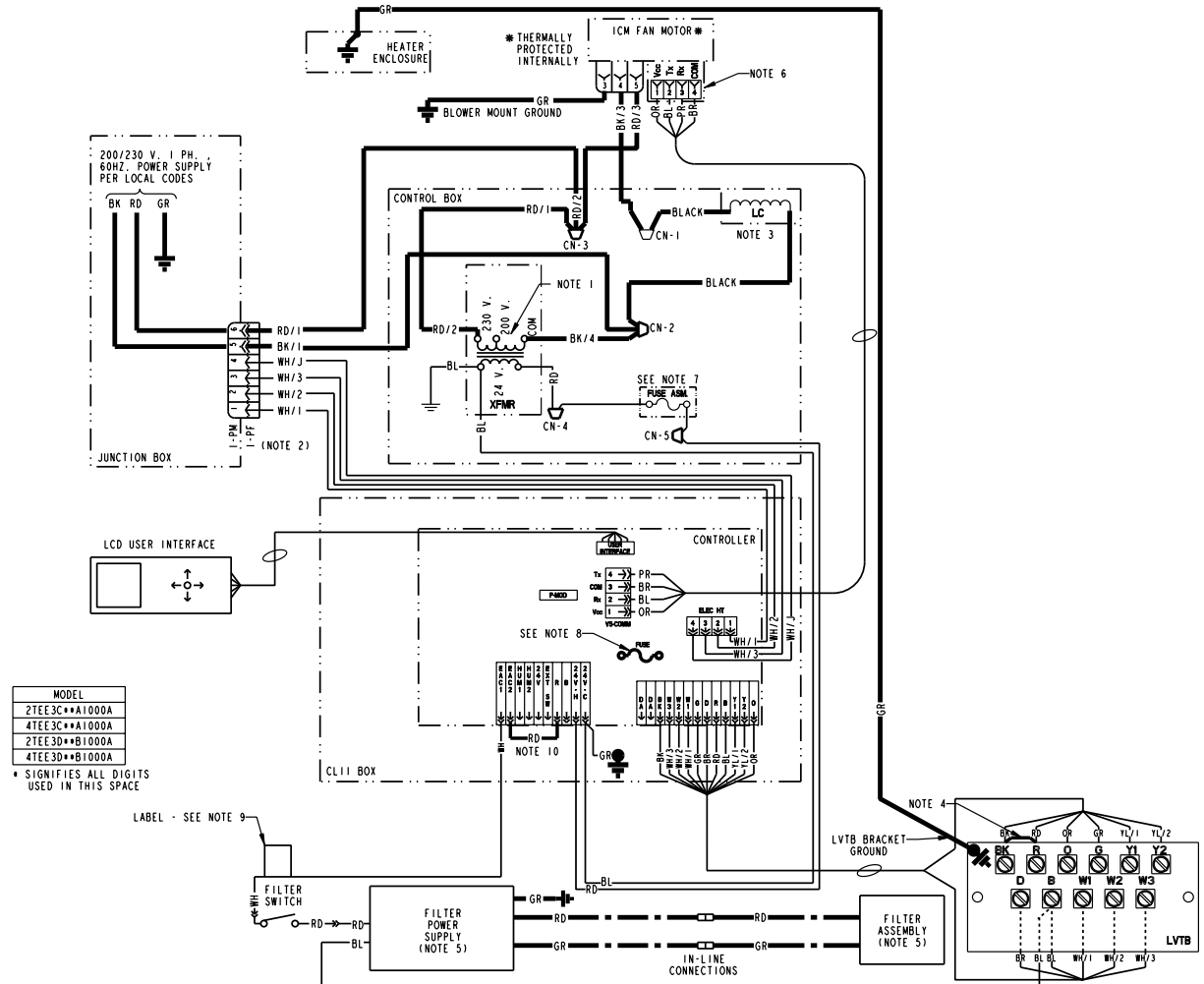

MODEL
2TEE3C**A1000A
4TEE3C**A1000A
2TEE30**B1000A
4TEE30**B1000A

* SIGNIFIES ALL DIGITS USED IN THIS SPACE

LEGEND

- 24 V. LINE V.
- MULTIWIRES HARNESS
- GROUND
- JUNCTION
- CAPACITOR
- WIRE NUT OR CONNECTOR
- TERMINAL
- TRANSFORMER
- FUSE
- TERMINAL BLOCK/BOARD
- RELAY CONTACT NO
- MAGNETIC COIL
- POL. PLUG FEMALE HOUSING (MALE TERMINALS)
- POL. PLUG MALE HOUSING (FEMALE TERMINALS)
- CN WIRE CONNECTOR
- MTR/ICM INTEGRAL CONTROL MOTOR
- LC LINE CHOKER
- LVTB LOW VOLTAGE TERMINAL BLOCK
- PF POLARIZED PLUG (FEMALE HOUSING)
- PFB POLARIZED PLUG (MALE HOUSING)
- XFMR TRANSFORMER
- EAC ELECTRONIC AIR CLEANER
- HUM HUMIDIFIER
- DA DISCHARGE AIR SENSOR
- EXTSW EXTERNAL SWITCH
- PMOD PERSONALITY MODULE (MODULE ALWAYS REMAINS WITH UNIT)
- COLOR OF WIRE: BK/BL (BLACK WIRE WITH BLUE MARKER), BK (BLACK), RD (RED), OR (ORANGE), BL (BLUE), WH (WHITE), GR (GREEN), BR (BROWN), YL (YELLOW), PR (PURPLE)

NOTES:

- FOR 200V OPERATION SWAP RED TRANSFORMER LEAD AND INSULATED CAP ON 200V CENTER TRANSFORMER TERMINAL.
- WHEN HEATERS ARE USED, DISCARD 1-PM WITH ATTACHED LEADS AND CONNECT 1-PF TO THE MATING PLUG IN THE HEATER CONTROL BOX.
- LINE CHOKER MAY NOT BE USED ON ALL MODELS. IF CHOKER NOT USED, BK/3 MTR (PIN4) LEAD CONNECTS TO BK/2 MTR(L2) TERMINAL.
- IF OPTIONAL HUMIDISTAT IS USED, REMOVE R TO BK JUMPER ON TERMINAL BOARD AND INSTALL HUMIDISTAT BETWEEN R AND BK. JUMPER R TO O FOR COOLING-ONLY NON-HEAT PUMP SYSTEMS WITH A HUMIDISTAT.
- FILTER ASSEMBLY, POWER SUPPLY & SWITCH, ARE USED ON 2/4TEE30**B MODELS ONLY.
- Rx (RECEIVE) ON MOTOR CONNECTS TO Tx (TRANSMIT) ON BOARD.
- FOR REPLACEMENT FUSE, USE LITTLE FUSE LMF 3-2/10 OR BUSSMAN GMD 3-2/10.
- 5 AMP AUTOMOTIVE TYPE FUSE TO PROTECT CONTROL BOARD.
- ON "C" MODELS, THE WHITE WIRE IS USED TO HOOKUP THE IFD FILTER POWER SUPPLY OR AN ADD ON EAC (SEE EAC INSTRUCTIONS FOR WIRING).
- REMOVE THIS JUMPER IF A 240/120 VOLT EAC IS TO BE APPLIED AND CONTROLLED VIA THE AH CONTROL.

WARNING
HAZARDOUS VOLTAGE!
DISCONNECT ALL ELECTRICAL POWER INCLUDING REMOTE DISCONNECTS BEFORE SERVICING.
Failure to disconnect power before servicing can cause severe personal injury or death.

CAUTION
USE COPPER CONDUCTORS ONLY!
UNIT TERMINALS ARE NOT DESIGNED TO ACCEPT OTHER TYPES OF CONDUCTORS.
Failure to do so may cause damage to the equipment.



TRANE®

Field Wiring

COMMUNICATING INDOOR UNIT WITH COMMUNICATING COMFORT CONTROL & COMMUNICATING OUTDOOR UNIT

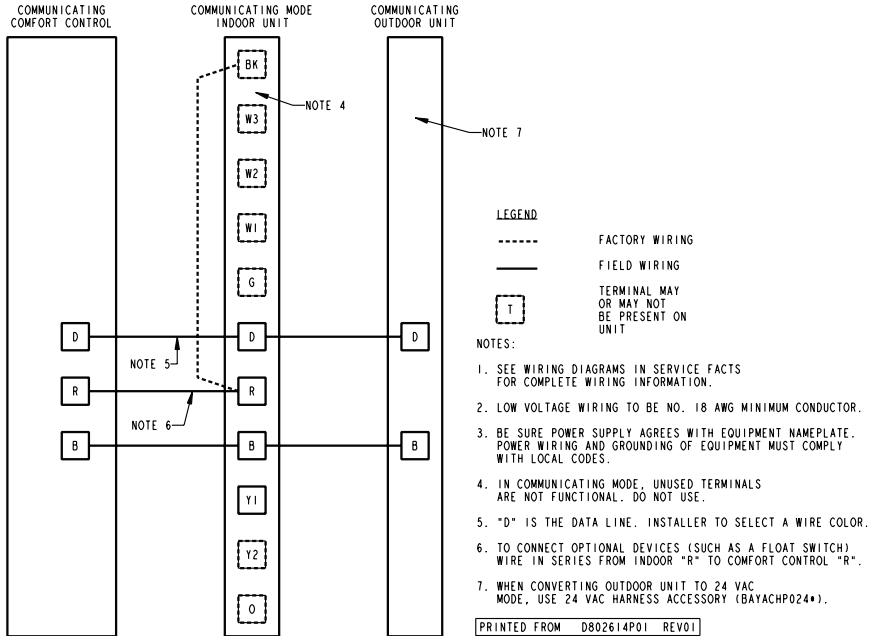

COMMUNICATING INDOOR UNIT WITH COMMUNICATING COMFORT CONTROL & 24 VAC SINGLE STAGE COOLING

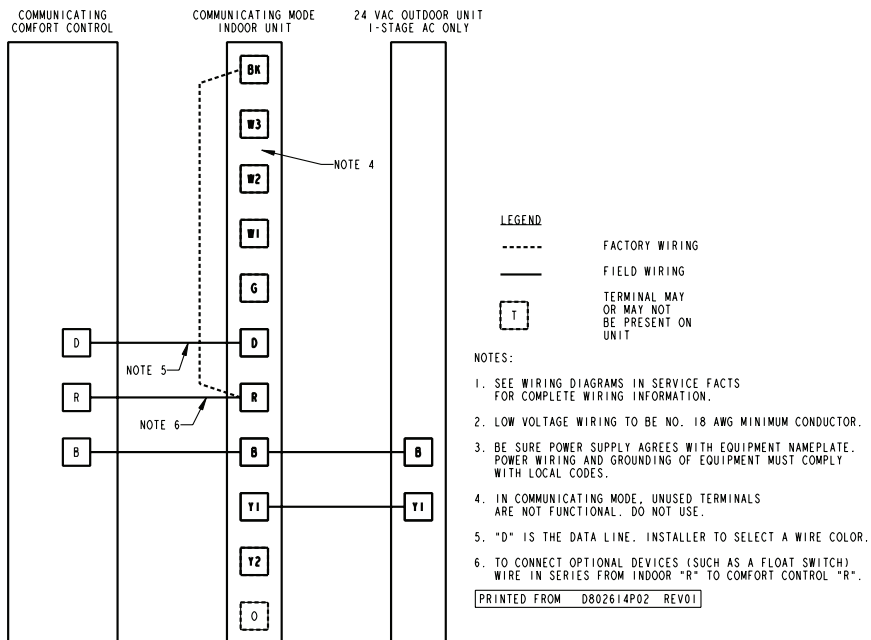

Field Wiring

COMMUNICATING INDOOR UNIT WITH 24 VAC COMFORT CONTROL & 24 VAC SINGLE STAGE COOLING

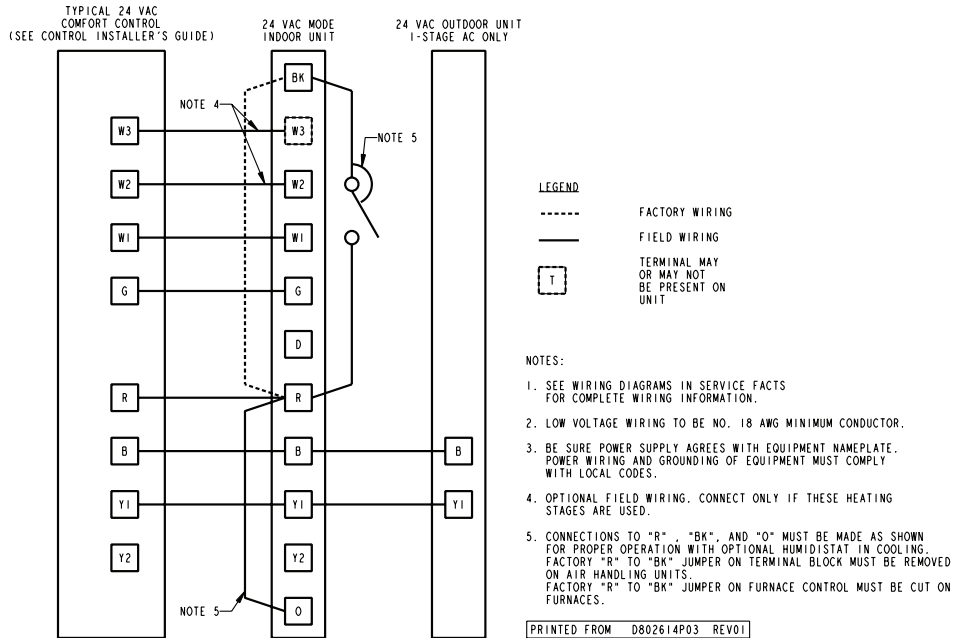

COMMUNICATING INDOOR UNIT WITH 24 VAC COMFORT CONTROL & 24 VAC 2-STAGE OR 2-STEP COOLING

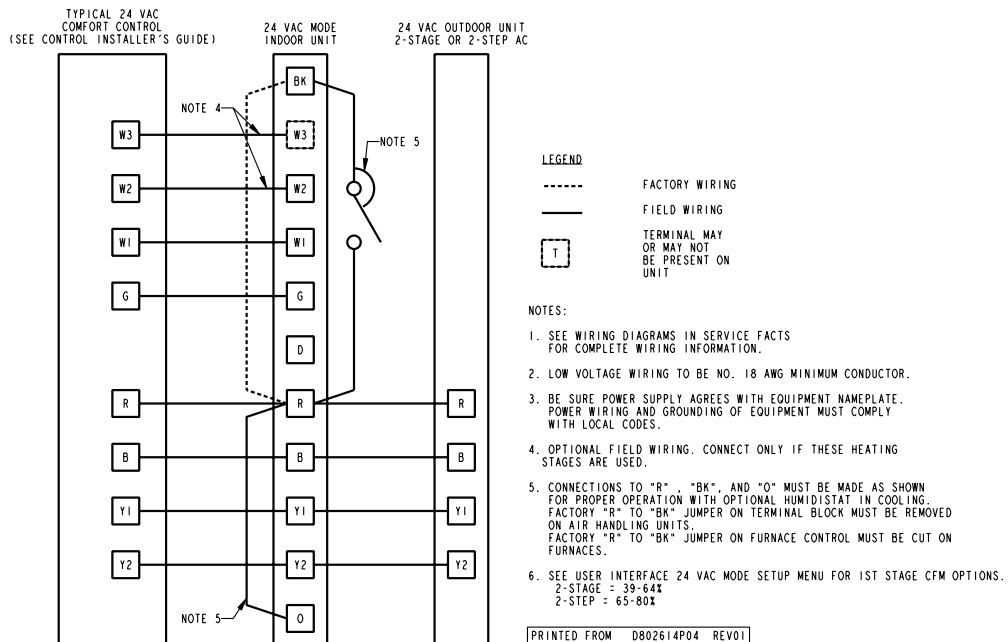



TRANE®

Field Wiring

COMMUNICATING INDOOR UNIT WITH 24 VAC COMFORT CONTROL & 24 VAC SINGLE STAGE HEAT PUMP

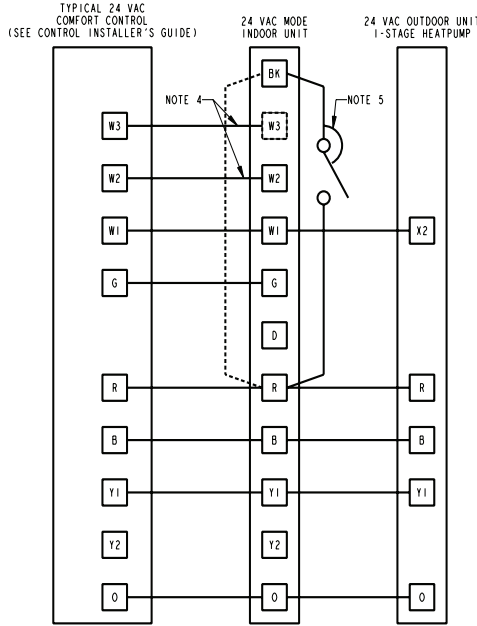

LEGEND

----- FACTORY WIRING
 _____ FIELD WIRING

T TERMINAL MAY OR MAY NOT BE PRESENT ON UNIT

- NOTES:**
1. SEE WIRING DIAGRAMS IN SERVICE FACTS FOR COMPLETE WIRING INFORMATION.
 2. LOW VOLTAGE WIRING TO BE NO. 18 AWG MINIMUM CONDUCTOR.
 3. BE SURE POWER SUPPLY AGREES WITH EQUIPMENT NAMEPLATE. POWER WIRING AND GROUNDING OF EQUIPMENT MUST COMPLY WITH LOCAL CODES.
 4. OPTIONAL FIELD WIRING. CONNECT ONLY IF THESE HEATING STAGES ARE USED.
 5. CONNECTIONS TO "R", "BK", AND "O" MUST BE MADE AS SHOWN FOR PROPER OPERATION WITH OPTIONAL HUMIDISTAT IN COOLING. FACTORY "R" TO "BK" JUMPER ON TERMINAL BLOCK MUST BE REMOVED ON AIR HANDLING UNITS. FACTORY "R" TO "BK" JUMPER ON FURNACE CONTROL MUST BE CUT ON FURNACES.
 6. ON FURNACE APPLICATIONS, COMFORT CONTROL MUST BE DUAL FUEL COMPATIBLE (SEE CONTROL INSTALLERS GUIDE) OR MUST USE TAYPLUS103.

PRINTED FROM D802614P05 REV01

COMMUNICATING INDOOR UNIT WITH 24 VAC COMFORT CONTROL & 24 VAC 2-STAGE OR 2-STEP HEAT PUMP

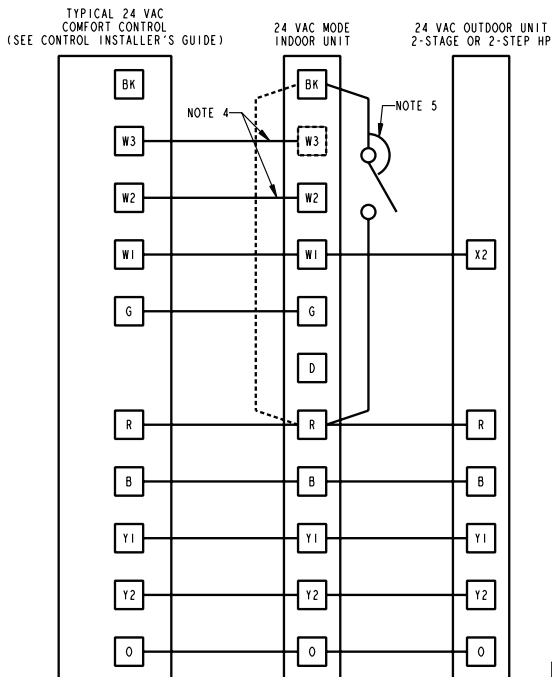

LEGEND

----- FACTORY WIRING
 _____ FIELD WIRING

T TERMINAL MAY OR MAY NOT BE PRESENT ON UNIT

- NOTES:**
1. SEE WIRING DIAGRAMS IN SERVICE FACTS FOR COMPLETE WIRING INFORMATION.
 2. LOW VOLTAGE WIRING TO BE NO. 18 AWG MINIMUM CONDUCTOR.
 3. BE SURE POWER SUPPLY AGREES WITH EQUIPMENT NAMEPLATE. POWER WIRING AND GROUNDING OF EQUIPMENT MUST COMPLY WITH LOCAL CODES.
 4. OPTIONAL FIELD WIRING. CONNECT ONLY IF THESE HEATING STAGES ARE USED.
 5. CONNECTIONS TO "R", "BK", AND "O" MUST BE MADE AS SHOWN FOR PROPER OPERATION WITH OPTIONAL HUMIDISTAT IN COOLING. FACTORY "R" TO "BK" JUMPER ON TERMINAL BLOCK MUST BE REMOVED ON AIR HANDLING UNITS. FACTORY "R" TO "BK" JUMPER ON FURNACE CONTROL MUST BE CUT ON FURNACES.
 6. ON FURNACE APPLICATIONS, COMFORT CONTROL MUST BE DUAL FUEL COMPATIBLE (SEE CONTROL INSTALLERS GUIDE) OR MUST USE TAYPLUS103.
 7. SEE USER INTERFACE 24 VAC MODE SETUP MENU FOR 1ST STAGE CFM OPTIONS.
 2-STAGE = 39-64%
 2-STEP = 65-80%

PRINTED FROM D802614P06 REV01

4TEE3D01-10B Convertibility

SIX (6) WAY CONVERTIBILITY

One Unit - 4 Applications (Conversions 1-4)

Horizontal Right (as shipped)

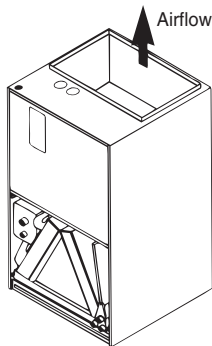
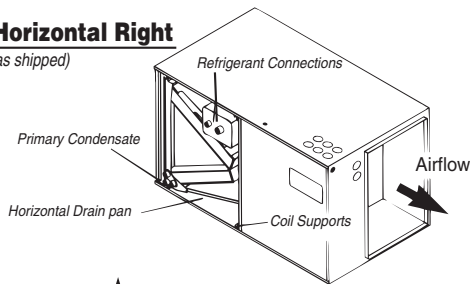

Vertical Upflow (as shipped) One-step Conversion Stand unit on end

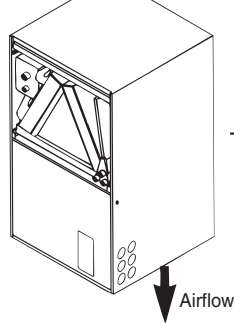
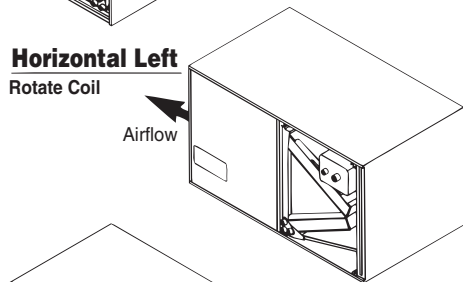

Vertical Downflow One-step Conversion from Horizontal left

Easy Conversion to Opposite side Access (Conversions 5 & 6)

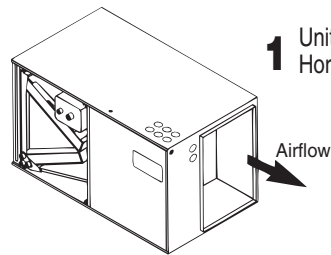

1 Unit is shipped as Horizontal right

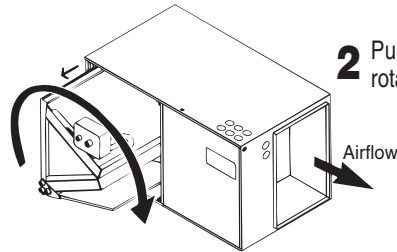

2 Pull coil out and rotate the coil 180°

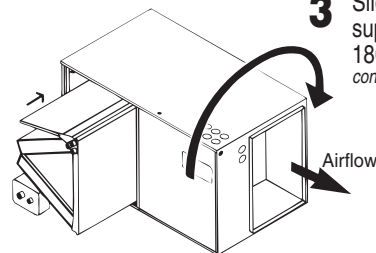

3 Slide coil back in on supports and roll unit 180° (so primary condensate is down)

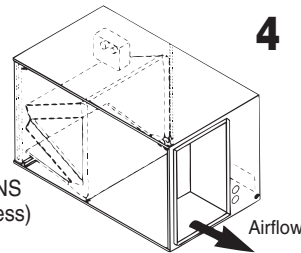

4 Note connections and access are now on back side of unit

- 6 CONVERSION APPLICATIONS
1. Horizontal Right - (Front Access)
 2. Vertical Upflow
 3. Horizontal Left - (Front Access)*
 4. Vertical Downflow*
 5. Horizontal Right - (Rear Access)
 6. Horizontal Left - (Rear Access)*

*Downflow and Horizontal Left orientations available with application of Downflow kit provided in Accessory Kit.



Dimensions

4TEE3D01-10 AIR HANDLERS DIMENSIONAL DATA

4TEE3D03, 04, 06, 08, 09 & 10A are two piece cabinets

Model No.	H	W
4TEE3D01A1000A	43.00	21.50
4TEE3D02A1000A	45.00	23.50
4TEE3D03A1000A	57.90	23.50
4TEE3D04A1000A	57.90	23.50
4TEE3D05A1000A	51.75	26.00
4TEE3D06A1000A	57.90	23.50
4TEE3D07A1000A	57.90	26.00
4TEE3D08A1000A	57.90	23.50
4TEE3D09A1000A	62.75	26.00
4TEE3D10A1000A	62.75	26.00

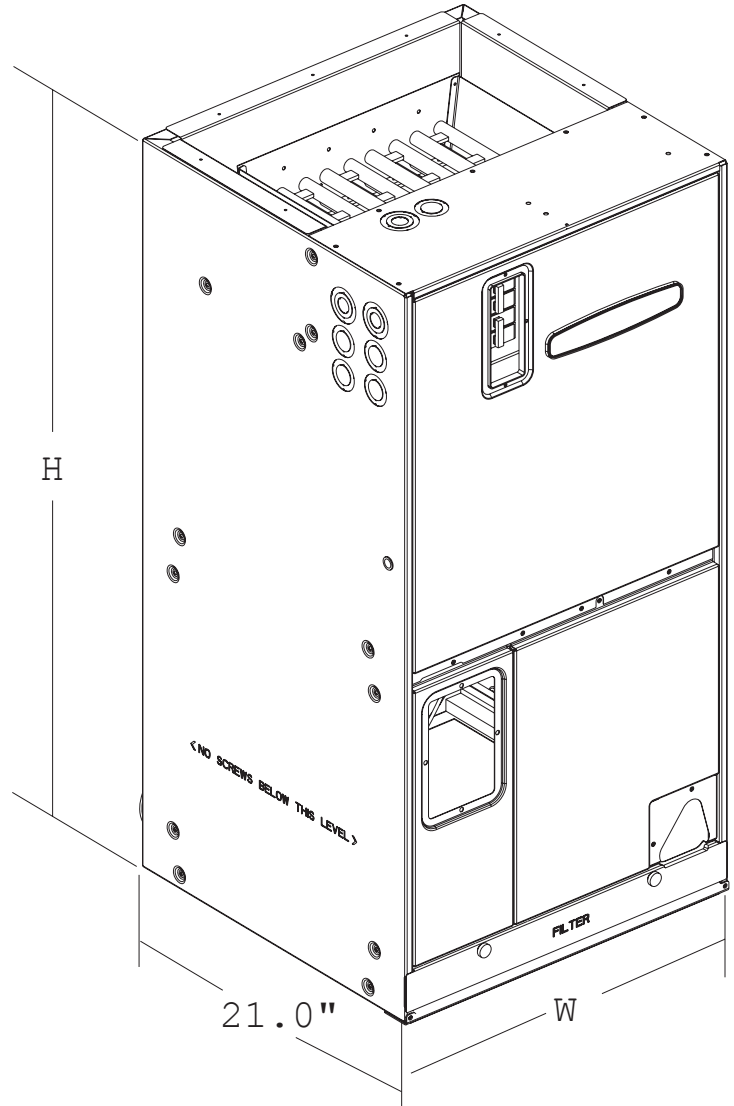

Outline Drawings

OUTLINE DRAWING FOR 4TEE3D01-10B AIR HANDLERS

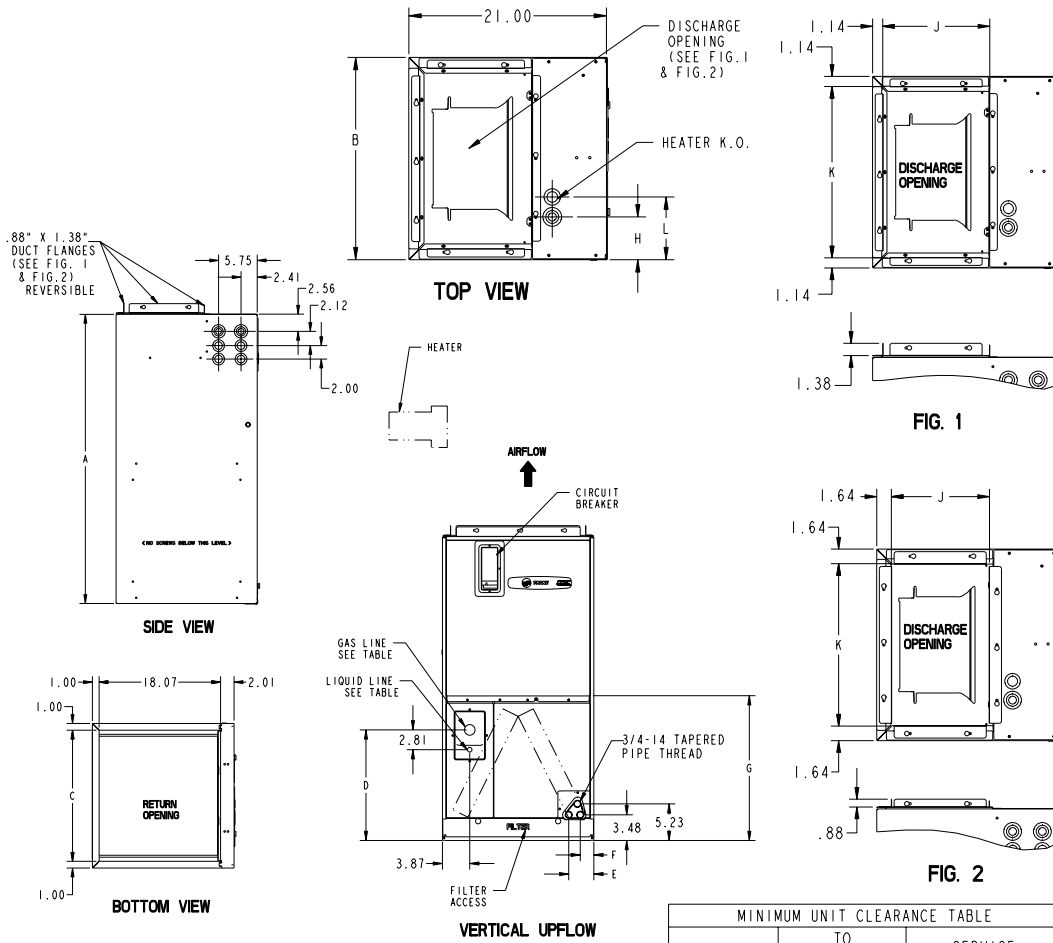

MODEL NO.	FIG. 1		FIG. 2	
	J	K	J	K
4TEE3C01, 4TEE3D01		19.5		18.5
4TEE3C02, 4TEE3D02, 4TEE3C03, 4TEE3D03, 4TEE3C04, 4TEE3D04, 4TEE3C06, 4TEE3D06, 4TEE3C08, 4TEE3D08,	12.0	21.5	11.0	20.5
4TEE3C05, 4TEE3D05, 4TEE3C07, 4TEE3D07, 4TEE3C09, 4TEE3D09, 4TEE3C10, 4TEE3D10		24.0		23.0

	TO COMBUSTIBLE MATERIAL (REQUIRED)	SERVICE CLEARANCE (RECOMMENDED)
SIDES	0"	2"
FRONT	0"	21"
BACK	0"	0"
INLET DUCT	0"	1"
OUTLET DUCT	1"*	

* 1" FOR THE FIRST 3 FT. OF OUTLET DUCT WHEN ELECTRIC HEATERS ARE INSTALLED.

MODEL NO.	A	B	C	D	E	F	G	H	L	GAS LINE BRAZE	LIQ. LINE BRAZE	FLOW CONTROL
4TEE3C01, 4TEE3D01	43	21.50	19.50	15.57	3.62	1.89	N/A	3.65	5.77	3/4	3/8	TXV/NB
4TEE3C02, 4TEE3D02	45	23.50	21.50	17.57				4.65	6.77			
4TEE3C05, 4TEE3D05,	51.75	26	24	18.33	3.21	1.48	36.00	5.90	8.02			
4TEE3C07, 4TEE3D07	57.90			27.12								
4TEE3C09, 4TEE3D09	62.75			17.00								
4TEE3C10, 4TEE3D10				26.77								
4TEE3C03, 4TEE3D03	57.90	23.50	21.50	17.00	3.62	1.89	31.15	4.65	6.77	5/8		
4TEE3C04, 4TEE3D04,				26.77						3/4		
4TEE3C06, 4TEE3D06, 4TEE3C08, 4TEE3D08												

Mechanical Specification Options

Features and General Information

These blower coil units are completely factory assembled including coil, condensate drain pan, fan, motor, and controls in an insulated casing that can be applied in horizontal or vertical configuration.

This new line of 4TEE3D air handlers provides exclusive compact size combined with multi-position capability.

The unit ships in the vertical upflow configuration and converts to right-hand horizontal configuration just by laying the unit on its side. No tools required. Simple coil rotation, along with application of downflow kit, provides downflow and horizontal left applications.

Comfort Control

ComfortLink II™ Communicating air handler design offers 3-wire connectivity for installation ease. Assures the entire heating and air conditioning system is set up in the proper modes to optimize the engineered performance of the matched system installed.

Casing

These models have a rugged galvanized sheet metal and steel frame construction. The casing is painted with an enamel fin-

ish. The casing is insulated and provides knockouts for electrical power and control wiring.

Filters

A Whole House Air Cleaner is integrated into the 4TEE3D air handler and includes a cleanable COLLECTION CELL.

Refrigerant Circuits

The 4TEE3D units have a single refrigerant circuit. The refrigerant circuit is controlled by a factory installed non-bleed thermal expansion valve (NB-TXV).

Coil

Aluminum fin surface is mechanically bonded to 3/8-inch OD copper tubing. Coils are factory pressure and leak tested.

Fan

The blower housing is forward curved, dynamically balanced with a variable speed direct drive fan motor. The variable speed ECM fan motor is permanently lubricated.

Controls

Low voltage terminal board, fan contactor, and plug-in module for accessory electric heat control is included. 4TEE3D models also have an internal check valve within the TXV.

Electric Heaters

Heaters for the 4TEE3D air handlers are available in a wide range of capacities and voltages with various staging options, and plug-in control wiring. Heaters fit inside the internal compartment.



Trane
6200 Troup Highway
Tyler, TX 75707
www.trane.com

09/09

Since Trane has a policy of continuous product and product data improvement, it reserves the right to change design and specifications without notice.