



**TRANE®**

22-1797-17A-EN

# Product Data

---

**4YCY4024 through 4YCY4060**

**Packaged Convertible Gas/Electric  
14 SEER**

**2 - 5 Ton, 60 - 120 MBTU**

**R-410A**

---

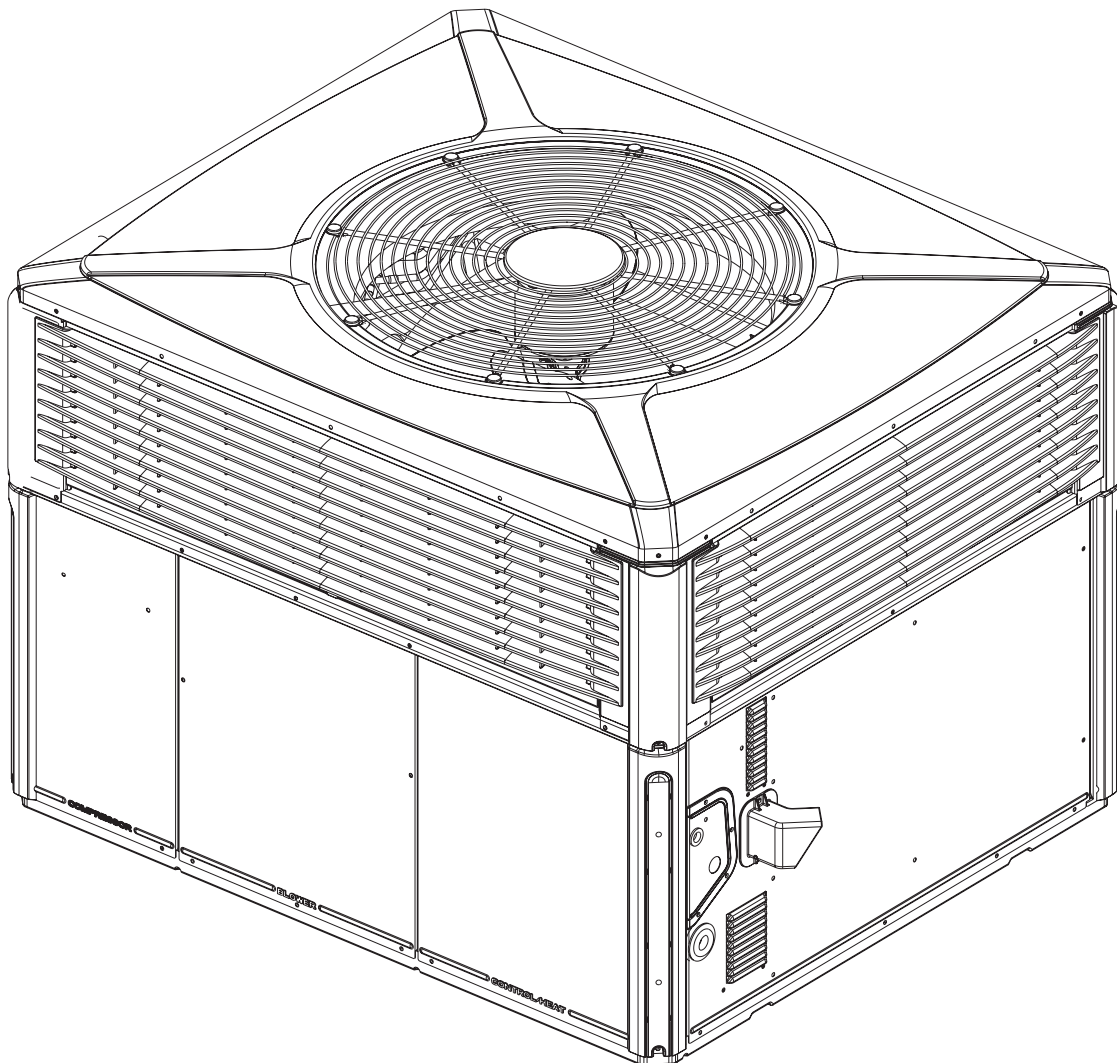

# It's Hard to Stop a Trane.

## **Packaged Convertible Gas/Electric System**

Trane offers a complete family of packaged gas/electric heating and cooling systems, designed to give you the unbeatable combination of energy efficiency and lower operating costs. In warm weather, the packaged gas/electric system functions as an all-electric, high efficiency air conditioner. In cold weather, it operates as a natural gas or propane gas furnace, offering you the best of both energy worlds.

## **Introducing the new TRANE Packaged Convertible Gas/Electric System.**

**Single Packaged Convertible Gas/Electric Systems are easy and versatile to install.** Because cooling and heating functions are all contained in a single cabinet, a Trane single packaged convertible gas/electric system is easy to install and service. It can be flush mounted beside your home at ground level or placed on the roof for horizontal or downflow installation. When connected to an optional Trane thermostat control, and air distribution ducts, you have a highly efficient, total home comfort system.

**Single Packaged Convertible Gas/Electric Systems are unmatched in quality and reliability.** All major components on these products, including the compressor, have been designed and manufactured for maximum service. Every Climatuff® compressor is designed and manufactured to exacting specifications. Each design is life tested in extreme environments to ensure reliable and long lasting operation in normal applications. Each compressor has internal motor protection for added reliability.

# Contents

<b>Optional Equipment Listing</b>	<b>4</b>
<hr/>	
<b>General Data</b>	<b>5</b>
<hr/>	
<b>Indoor Blower Performance</b>	<b>9</b>
<hr/>	
<b>Typical Field Wiring</b>	<b>13</b>
<hr/>	
<b>Optional Equipment</b>	<b>16</b>
<hr/>	
<b>Dimensional Data</b>	<b>21</b>
<hr/>	
<b>Mechanical Specifications</b>	<b>27</b>
<hr/>	

# Optional Equipment Listing

## OPTIONAL EQUIPMENT FOR PACKAGED UNITS (check mark [✓] indicates accessories included)

Hinged Filter Access Door (4YCY4024-036) ⑥	BAYACCDOR1A[ ]
Hinged Filter Access Door (4YCY4042-060) ⑥	BAYACCDOR2A[ ]
Roof Curb Full Perimeter (4YCY4024-36) ③	BAYCURB050A[ ]
Roof Curb Full Perimeter (4YCY4042-60) ③	BAYCURB051A[ ]
Roof Curb Utility Extension Kit (BAYCURB050A)	BAYUTIL101B[ ]
Roof Curb Utility Extension Kit (BAYCURB051A)	BAYUTIL102B[ ]
0-25% Manual Fresh Air Damper (4YCY4024-36) ①	BAYOSAH001A[ ]
0-25% Manual Fresh Air Damper (4YCY4042-60) ①	BAYOSAH002A[ ]
Motorized Fresh Air Damper (4YCY4024-36) ①	BAYDMPR101A[ ]
Motorized Fresh Air Damper (4YCY4042-60) ①	BAYDMPR102A[ ]
16" Round Duct Adapter (2 per box) (4YCY4024-36) ⑥	BAYSQRD001A[ ]
18" Round Duct Adapter (2 per box) (4YCY4024-60) ⑥	BAYSQRD002A[ ]
0-100% Mod Economizer w/Baro. Relief (4YCY4024-36) ①②④	BAYECON101B[ ]
0-100% Mod. Economizer w/Baro. Relief (4YCY4042-60) ①②④	BAYECON102B[ ]
0-100% Horizontal Economizer (4YCY4024-36) ①②	BAYECON200A[ ]
0-100% Horizontal Economizer (4YCY4042-60) ①②	BAYECON201A[ ]
Enthalpy Control for Economizer (solid state)	BAYENTH001A[ ]
Remote Potentiometer (All-BAYECON***A)	BAYSTAT023[ ]
1"-2" Filter Frame (4YCY4024-36) (20 x 25 filter not included) ①	BAYFLTR101B[ ]
1"-2" Filter Frame (4YCY4042-60) (20 x 20 & 20 x 18 filter not included) ①	BAYFLTR201B[ ]
LP Conversion Kit (All 40K, 120K Models)	BAYLPKT100A[ ]
LP Conversion Kit (All 64K, 96K Models)	BAYLPKT101A[ ]
LP Conversion Kit (All 75K Models)	BAYLPKT102A[ ]
Head Pressure Control (Low Ambient Cool) (208/240v) Kit ⑤	BAYLOAM105A[ ]
Quick Start Kit (4YCY4-†1)	BAYQSKT301A[ ]
Crankcase Heater Recip (4YCY4024-030) (230v) ⑤	BAYCCHT101A[ ]
Crankcase Heater Scroll (4YCY4042-060†1/3)(230v) ⑤	BAYCCHT102A[ ]
Crankcase Heater Scroll (4YCY4036)(230v) ⑤	BAYCCHT103A[ ]
Adapter Curb 4YCY4024-036 to BAYCURB030,38	BAYADAP050A[ ]
Adapter Curb 4YCY4024-036 to BAYCURB033	BAYADAP051A[ ]
Adapter Curb 4YCY4042-060 to BAYCURB030,38	BAYADAP052A[ ]
Adapter Curb 4YCY4042-060 to BAYCURB033	BAYADAP053A[ ]
Adapter Curb 4YCY4042-060 to BAYCURB034	BAYADAP054A[ ]
12" Duct Shroud Covers Horizontal 4YCY4024-060⑦	BAYCOVR112A[ ]
18" Duct Shroud Covers Horizontal 4YCY4024-060⑦	BAYCOVR118A[ ]
Extreme Condition Mounting Kit - All BAYCURB & BAYADAP	BAYEXMK001A[ ]
Extreme Condition Mounting Kit - All BAYUTIL	BAYEXMK002B[ ]
Extreme Condition Mounting Kit - All Slab Mounts	BAYEXMK003A[ ]
Lifting Lug Kit	BAYLIFT002B[ ]

- NOTES:
- ① Must use filter frame when economizer/fresh air kit is used.
  - ② Dry bulb control standard with economizer.
  - ③ Ships knocked down.
  - ④ Downflow only.
  - ⑤ Low Ambient cooling requires crankcase heater (BAYCCHT---A).
  - ⑥ It is the responsibility of the installing dealer to properly size the ductwork for each specific application.
  - ⑦ BAYCOVR112,118A will not cover BAYSQRD002A applications
  - ⑧ BAYACCDOR1A requires BAYFLTR101B & BAYACCDOR2A requires BAYFLTR201B. They are not backward compatible to BAYFLTR101/201A.
- † = A or B

# General Data

MODEL	4YCY4024C1060A	4YCY4030C1070A	4YCY4036C1070A	4YCY4036C1090A
<b>RATED Volts/PH/Hz</b>	208-230/1/60	208-230/1/60	208-230/1/60	208-230/1/60
<b>Performance Cooling BTUH</b> ⓐ	23400	30000	38000	38000
Indoor Airflow (CFM)	790	900	1210	1210
Power Input (KW)	2.162	2.5	3.166	3.166
EER/SEER(BTU/Watt-Hr.)ⓑ	12/14.0	12.0 / 14.0	12.0 / 14.2	12.0 / 14.2
Sound Power Rating [dB(A)]ⓑ	68	71	69	69
<b>Performance Heating</b> ⓐ				
Input BTUH - 1st Stage (Natural Gas)	48000	56000	56000	72000
Input BTUH - 2nd Stage (Natural Gas)	60000	70000	70000	90000
AFUE	81	81	81	81
Temp. Rise — Min/Max (°F)	40 / 40	30 / 60	30 / 60	40 / 70
Orifice Qty / Drill Size (Natural Gas)ⓑ	2 / #37	2 / #33	2 / #33	3 / #37
<b>POWER CONN.—V/PH/HZ</b>	208-230/1/60	208-230/1/60	208-230/1/60	208-230/1/60
Min. Brch. Cir. Ampacityⓐ	16.5	19.2	24.6	24.6
Fuse Size — Max. (amps)	25	30	40	40
Fuse Size — Recmd. (amps)	25	30	40	40
<b>COMPRESSOR</b>	RECIPROCATING	RECIPROCATING	SCROLL	SCROLL
Volts/Ph/Hz	208-230/1/60	200-230/1/60	208-230/1/60	208-230/1/60
R.L. Amps — L.R. Amps	8.3 / 57.8	11.1 / 63	15.4 / 83	15.4 / 83
<b>OUTDOOR COIL — TYPE</b>	SPINE-FIN	SPINE-FIN	SPINE-FIN	SPINE-FIN
Rows/F.P.I.	2 / 24	2 / 24	2 / 24	2 / 24
Face Area (sq.ft.)	13.32	13.32	15.49	15.49
Tube Size (in.)	3/8	3/8	3/8	3/8
<b>INDOOR COIL — TYPE</b>	PLATE FIN	PLATE FIN	PLATE FIN	PLATE FIN
Rows/F.P.I.	3 / 15	3 / 15	4 / 15	4 / 15
Face Area (sq.ft.)	3.54	3.54	3.54	3.54
Tube Size (in.)	3/8	3/8	3/8	3/8
Refrigerant Control	EXPANSION VALVE	EXPANSION VALVE	EXPANSION VALVE	EXPANSION VALVE
Drain Conn. Size (in.)	3/4 FEMALE NPT	3/4 FEMALE NPT	3/4 FEMALE NPT	3/4 FEMALE NPT
<b>OUTDOOR FAN — TYPE</b>	PROPELLER	PROPELLER	PROPELLER	PROPELLER
Dia. (in.)	23.4	23.4	23.4	23.4
Drive/No. Speeds	DIRECT / 1	DIRECT / 1	DIRECT / 1	DIRECT / 1
CFM @ 0.0 in. w.g. ⓑ	2570	3260	3320	3320
Motor — HP/R.P.M.	1/12 / 810	1/6 / 830	1/5 / 830	1/5 / 830
Volts/Ph/Hz	208-230/1/60	208-230/1/60	208-230/1/60	208-230/1/60
F.L. Amps/L.R. Amps	0.54 / 0.95	1.0 / 1.7	1.1 / 1.9	1.1 / 1.9
<b>INDOOR FAN — TYPE</b>	CENTRIFUGAL	CENTRIFUGAL	CENTRIFUGAL	CENTRIFUGAL
Dia x Width (in.)	10 X 10	10 X 10	10 X 10	10 X 10
Drive/No. Speeds	DIRECT / VARIABLE	DIRECT / VARIABLE	DIRECT / VARIABLE	DIRECT / VARIABLE
CFM @ 0.0 in. w.g.ⓑ	SEE FAN PERFORMANCE TABLE	SEE FAN PERFORMANCE TABLE	SEE FAN PERFORMANCE TABLE	SEE FAN PERFORMANCE TABLE
Motor — HP/R.P.M.	1/2 / VARIABLE	1/2 / VARIABLE	1/2 / VARIABLE	1/2 / VARIABLE
Volts/Ph/Hz	200-230/1/60	208-230/1/60	200-230/1/60	200-230/1/60
F.L. Amps/L.R. Amps	4.3 / 4.3	4.3 / 4.3	4.3 / 4.3	4.3 / 4.3
<b>COMBUSTION FAN — TYPE</b>	CENTRIFUGAL	CENTRIFUGAL	CENTRIFUGAL	CENTRIFUGAL
Drive/No. Speeds	DIRECT / 2	DIRECT / 2	DIRECT / 2	DIRECT / 2
Motor — HP/R.P.M.	1/20 / 3350/2600	1/20 / 3350/2600	1/20 / 3350/2600	1/20 / 3350/2600
Volts/Ph/Hz	208-230/1/60	208-230/1/60	208-230/1/60	208-230/1/60
FLA	0.34	0.34	0.34	0.34
<b>FILTER / FURNISHED</b>	NO	NO	NO	NO
Type Recommended	THROWAWAY	THROWAWAY	THROWAWAY	THROWAWAY
Recmd. Face Area (sq. ft.)ⓑ	4	4	4	4
<b>REFRIGERANT</b>	R410A	R410A	R410A	R410A
Charge (lbs.)ⓑ	6.0	6.30	7.9	7.9
<b>GAS PIPE SIZE (in.)</b>	1/2	1/2	1/2	1/2
<b>DIMENSIONS</b>	H X W X L	H X W X L	H X W X L	H X W X L
Crated (in.)	45.86 / 44.5 / 52.03	45.86 / 44.5 / 52.03	47.86 / 44.5 / 52.03	47.86 / 44.5 / 52.03
<b>WEIGHT</b>				
Shipping (lbs.) / Net (lbs.)	481 / 385	481 / 385	488 / 392	493 / 397

ⓐ Certified in accordance with the Unitary Air-Conditioner Equipment certification program, which is based on AHRI Standard 210/240. Sound Power values are not adjusted for AHRI 270-95 tonal corrections.

ⓑ All models are certified to UL 1995. Ratings shown are for elevations up to 2000 ft. For higher elevations reduce ratings at a rate of 4% per 1000 ft. elevation.

ⓒ Convertible to LPG.

ⓓ This value is approximate. For more precise value, see Unit Nameplate.

ⓔ Based on U.S. Government Standard Tests.

ⓕ Filters must be installed in return air stream. Square footages listed are based on 300 f.p.m. face velocity. If permanent filters are used size per manufacturer's recommendation with a clean resistance of 0.05" W.C.

ⓖ Standard Air - Dry Coil - Outdoor.

# General Data

MODEL	4YCY4036B3075A	4YCY4036A3096A	4YCY4042C1090A
<b>RATED Volts/PH/Hz</b>	208-230/3/60	208-230/3/60	208-230/1/60
<b>Performance Cooling BTUH</b> ①	36000	36000	42000
Indoor Airflow (CFM)	1210	1210	1370
Power Input (KW)	3.284	3.284	3.5
EER/SEER(BTU/Watt-Hr.)⑤	11.6 / 14.2	11.6 / 14.2	12.0 / 14.25
Sound Power Rating [dB(A)]②	69	69	74
<b>Performance Heating</b> ②			
Input BTUH - 1st Stage (Natural Gas)	56250	72000	72000
Input BTUH - 2nd Stage (Natural Gas)	75000	96000	90000
AFUE	80	80	81
Temp. Rise — Min/Max (°F)	30 / 60	40 / 70	30 / 60
Orifice Qty / Drill Size (Natural Gas)③	2 / #33	3 / #37	3 / #37
<b>POWER CONN.—V/PH/Hz</b>	208-230/3/60	208-230/3/60	208-230/1/60
Min. Brch. Cir. Ampacity④	19.8	19.8	31.5
Fuse Size — Max. (amps)	30	30	50
Fuse Size — Recmd. (amps)	30	30	50
<b>COMPRESSOR</b>	SCROLL	SCROLL	SCROLL
Volts/Ph/Hz	208-230/3/60	208-230/3/60	208-230/1/60
R.L. Amps — L.R. Amps	11.5 / 77	11.5 / 77	18.6 / 105
<b>OUTDOOR COIL — TYPE</b>	SPINE-FIN	SPINE-FIN	SPINE-FIN
Rows/F.P.I.	2 / 24	2 / 24	2 / 24
Face Area (sq.ft.)	15.49	15.49	18.01
Tube Size (in.)	3/8	3/8	3/8
<b>INDOOR COIL — TYPE</b>	PLATE FIN	PLATE FIN	PLATE FIN
Rows/F.P.I.	4 / 15	4 / 15	3 / 15
Face Area (sq.ft.)	3.54	3.54	5
Tube Size (in.)	3/8	3/8	3/8
Refrigerant Control	EXPANSION VALVE	EXPANSION VALVE	EXPANSION VALVE
Drain Conn. Size (in.)	3/4 FEMALE NPT	3/4 FEMALE NPT	3/4 FEMALE NPT
<b>OUTDOOR FAN — TYPE</b>	PROPELLER	PROPELLER	PROPELLER
Dia. (in.)	23.4	23.4	28.2
Drive/No. Speeds	DIRECT / 1	DIRECT / 1	DIRECT / 1
CFM @ 0.0 in. w.g. ⑦	3280	3280	4480
Motor — HP/R.P.M.	1/5 / 830	1/5 / 830	1/4 / 825
Volts/Ph/Hz	208-230/1/60	208-230/1/60	208-230/1/60
F.L. Amps/L.R. Amps	1.1 / 1.9	1.1 / 1.9	1.5 / 3.4
<b>INDOOR FAN — TYPE</b>	CENTRIFUGAL	CENTRIFUGAL	CENTRIFUGAL
Dia x Width (in.)	10 X 10	10 X 10	11 X 10
Drive/No. Speeds	DIRECT / VARIABLE	DIRECT / VARIABLE	DIRECT / VARIABLE
CFM @ 0.0 in. w.g.⑤	SEE FAN PERFORMANCE TABLE	SEE FAN PERFORMANCE TABLE	SEE FAN PERFORMANCE TABLE
Motor — HP/R.P.M.	1/2 / VARIABLE	1/2 / VARIABLE	3/4 / VARIABLE
Volts/Ph/Hz	200-230/1/60	200-230/1/60	208-230/1/60
F.L. Amps/L.R. Amps	4.3 / 4.3	4.3 / 4.3	6.8 / 6.8
<b>COMBUSTION FAN — TYPE</b>	CENTRIFUGAL	CENTRIFUGAL	CENTRIFUGAL
Drive/No. Speeds	DIRECT / 2	DIRECT / 2	DIRECT / 2
Motor — HP/R.P.M.	1/45 / 2800/1500	1/45 / 2800/1500	1/20 / 3350/2600
Volts/Ph/Hz	208-230/1/60	208-230/1/60	208-230/1/60
FLA	0.34	0.34	0.34
<b>FILTER / FURNISHED</b>	NO	NO	NO
Type Recommended	THROWAWAY	THROWAWAY	THROWAWAY
Recmd. Face Area (sq. ft.)⑥	4	4	5.3
<b>REFRIGERANT</b>	R410A	R410A	R410A
Charge (lbs.)④	6.75	6.75	6.8125
<b>GAS PIPE SIZE (in.)</b>	1/2	1/2	1/2
<b>DIMENSIONS</b>	H X W X L	H X W X L	H X W X L
Crated (in.)	47.86 / 44.5 / 52.03	47.86 / 44.5 / 52.03	47.86 / 47.4 / 61.75
<b>WEIGHT</b>			
Shipping (lbs.) / Net (lbs.)	488 / 392	493 / 397	653 / 525

① Certified in accordance with the Unitary Air-Conditioner Equipment certification program, which is based on AHRI Standard 210/240. Sound Power values are not adjusted for AHRI 270-95 tonal corrections.

② All models are certified to UL 1995. Ratings shown are for elevations up to 2000 ft. For higher elevations reduce ratings at a rate of 4% per 1000 ft. elevation.

③ Convertible to LPG.

④ This value is approximate. For more precise value, see Unit Nameplate.

⑤ Based on U.S. Government Standard Tests.

⑥ Filters must be installed in return air stream. Square footages listed are based on 300 f.p.m. face velocity. If permanent filters are used size per manufacturer's recommendation with a clean resistance of 0.05" W.C.

⑦ Standard Air - Dry Coil - Outdoor.

# General Data

MODEL	4YCY4048C1090A	4YCY4048C1115A	4YCY4048B3096A
<b>RATED Volts/PH/Hz</b>	208-230/1/60	208-230/1/60	208-230/3/60
<b>Performance Cooling BTUH</b> ①	48500	48500	48000
Indoor Airflow (CFM)	1605	1605	1605
Power Input (KW)	4.041	4.041	4.034
EER/SEER(BTU/Watt-Hr.)⑤	12 / 14.2	12 / 14.2	11.9 / 14.2
Sound Power Rating [dB(A)]①	73	73	73
<b>Performance Heating</b> ②			
Input BTUH - 1st Stage (Natural Gas)	72000	90000	72000
Input BTUH - 2nd Stage (Natural Gas)	90000	115000	96000
AFUE	81	81	80
Temp. Rise — Min/Max (°F)	30 / 60	40 / 70	30 / 60
Orifice Qty / Drill Size (Natural Gas)③	3 / #37	3 / #37	3 / #37
<b>POWER CONN.—V/PH/Hz</b>	208-230/1/60	208-230/1/60	208-230/3/60
Min. Brch. Cir. Ampacity④	35.4	35.4	26.4
Fuse Size — Max. (amps)	50	50	40
Fuse Size — Recmd. (amps)	50	50	40
<b>COMPRESSOR</b>	SCROLL	SCROLL	SCROLL
Volts/Ph/Hz	208-230/1/60	208-230/1/60	208-230/3/60
R.L. Amps — L.R. Amps	21.8 / 117	21.8 / 117	14.6 / 91
<b>OUTDOOR COIL — TYPE</b>	SPINE-FIN	SPINE-FIN	SPINE-FIN
Rows/F.P.I.	2 / 24	2 / 24	2 / 24
Face Area (sq.ft.)	18.01	18.01	18.01
Tube Size (in.)	3/8	3/8	3/8
<b>INDOOR COIL — TYPE</b>	PLATE FIN	PLATE FIN	PLATE FIN
Rows/F.P.I.	3 / 15	3 / 15	3 / 15
Face Area (sq.ft.)	5.0	5.0	5.0
Tube Size (in.)	3/8	3/8	3/8
Refrigerant Control	EXPANSION VALVE	EXPANSION VALVE	EXPANSION VALVE
Drain Conn. Size (in.)	3/4 FEMALE NPT	3/4 FEMALE NPT	3/4 FEMALE NPT
<b>OUTDOOR FAN — TYPE</b>	PROPELLER	PROPELLER	PROPELLER
Dia. (in.)	28.2	28.2	28.2
Drive/No. Speeds	DIRECT / 1	DIRECT / 1	DIRECT / 1
CFM @ 0.0 in. w.g. ⑦	4470	4470	4470
Motor — HP/R.P.M.	1/4 / 825	1/4 / 825	1/4 / 825
Volts/Ph/Hz	208-230/1/60	208-230/1/60	208-230/1/60
F.L. Amps/L.R. Amps	1.4 / 3.5	1.4 / 3.37	1.4 / 3.5
<b>INDOOR FAN — TYPE</b>	CENTRIFUGAL	CENTRIFUGAL	CENTRIFUGAL
Dia x Width (in.)	11 X 10	11 X 10	11 X 10
Drive/No. Speeds	DIRECT / VARIABLE	DIRECT / VARIABLE	DIRECT / VARIABLE
CFM @ 0.0 in. w.g.⑤	SEE FAN PERFORMANCE TABLE	SEE FAN PERFORMANCE TABLE	SEE FAN PERFORMANCE TABLE
Motor — HP/R.P.M.	3/4 / VARIABLE	3/4 / VARIABLE	3/4 / VARIABLE
Volts/Ph/Hz	200-230/1/60	200-230/1/60	200-230/1/60
F.L. Amps/L.R. Amps	6.8 / 6.8	6.8 / 6.8	6.8 / 6.8
<b>COMBUSTION FAN — TYPE</b>	CENTRIFUGAL	CENTRIFUGAL	CENTRIFUGAL
Drive/No. Speeds	DIRECT / 2	DIRECT / 2	DIRECT / 2
Motor — HP/R.P.M.	1/20 / 3350/2600	1/20 / 3350/2600	1/45 / 2800/1500
Volts/Ph/Hz	208-230/1/60	208-230/1/60	208-230/1/60
FLA	0.34	0.34	0.34
<b>FILTER / FURNISHED</b>	NO	NO	NO
Type Recommended	THROWAWAY	THROWAWAY	THROWAWAY
Recmd. Face Area (sq. ft.)⑥	5.3	5.3	5.3
<b>REFRIGERANT</b>	R410A	R410A	R410A
Charge (lbs.)④	8.0	8.0	8.2
<b>GAS PIPE SIZE (in.)</b>	1/2	1/2	1/2
<b>DIMENSIONS</b>	H X W X L	H X W X L	H X W X L
Crated (in.)	47.86 / 47.4 / 61.75	47.86 / 47.4 / 61.75	47.86 / 47.4 / 61.75
<b>WEIGHT</b>			
Shipping (lbs.) / Net (lbs.)	669 / 541	675 / 547	653 / 525

① Certified in accordance with the Unitary Air-Conditioner Equipment certification program, which is based on AHRI Standard 210/240. Sound Power values are not adjusted for AHRI 270-95 tonal corrections.

② All models are certified to UL 1995. Ratings shown are for elevations up to 2000 ft. For higher elevations reduce ratings at a rate of 4% per 1000 ft. elevation.

③ Convertible to LPG.

④ This value is approximate. For more precise value, see Unit Nameplate.

⑤ Based on U.S. Government Standard Tests.

⑥ Filters must be installed in return air stream. Square footages listed are based on 300 f.p.m. face velocity. If permanent filters are used size per manufacturer's recommendation with a clean resistance of 0.05" W.C.

⑦ Standard Air - Dry Coil - Outdoor.



# General Data

MODEL	4YCY4048B3120A	4YCY4060C1115A	4YCY4060A3120B
<b>RATED Volts/PH/Hz</b>	208-230/3/60	208-230/1/60	208-230/3/60
<b>Performance Cooling BTUH</b> ①	48000	58500	58500
Indoor Airflow (CFM)	1605	1800	1800
Power Input (KW)	4.034	5.478	5.478
EER/SEER(BTU/Watt-Hr.)⑤	11.9 / 14.2	12/14.0	12/14.0
Sound Power Rating [dB(A)]①	73	76	76
<b>Performance Heating</b> ②			
Input BTUH - 1st Stage (Natural Gas)	90000	90000	90000
Input BTUH - 2nd Stage (Natural Gas)	120000	115000	120000
AFUE	80	81	80
Temp. Rise — Min/Max (°F)	40 / 70	30 / 60	30 / 60
Orifice Qty / Drill Size (Natural Gas)③	3 / #32	3 / #32	3 / #32
<b>POWER CONN.—V/PH/Hz</b>	208-230/3/60	208-230/1/60	208-230/3/60
Min. Brch. Cir. Ampacity④	26.4	42.3	28.6
Fuse Size — Max. (amps)	40	60	40
Fuse Size — Recmd. (amps)	40	60	40
<b>COMPRESSOR</b>	SCROLL	SCROLL	SCROLL
Volts/Ph/Hz	208-230/3/60	208-230/1/60	208-230/3/60
R.L. Amps — L.R. Amps	14.6 / 91	26.9 / 145	17.6 / 123
<b>OUTDOOR COIL — TYPE</b>	SPINE-FIN	SPINE-FIN	SPINE-FIN
Rows/F.P.I.	2 / 24	2 / 24	2 / 24
Face Area (sq.ft.)	18.01	23.57	23.57
Tube Size (in.)	3/8	3/8	3/8
<b>INDOOR COIL — TYPE</b>	PLATE FIN	PLATE FIN	PLATE FIN
Rows/F.P.I.	3 / 15	4 / 15	4 / 15
Face Area (sq.ft.)	5.0	5.0	5.0
Tube Size (in.)	3/8	3/8	3/8
Refrigerant Control	EXPANSION VALVE	EXPANSION VALVE	EXPANSION VALVE
Drain Conn. Size (in.)	3/4 FEMALE NPT	3/4 FEMALE NPT	3/4 FEMALE NPT
<b>OUTDOOR FAN — TYPE</b>	PROPELLER	PROPELLER	PROPELLER
Dia. (in.)	28.2	28.2	28.2
Drive/No. Speeds	DIRECT / 1	DIRECT / 1	DIRECT / 1
CFM @ 0.0 in. w.g. ⑦	4470	5730	5730
Motor — HP/R.P.M.	1/4 / 825	1/3 / 830	1/3 / 830
Volts/Ph/Hz	208-230/1/60	208-230/1/60	208-230/1/60
F.L. Amps/L.R. Amps	1.4 / 3.37	1.7 / 3.5	1.7 / 3.5
<b>INDOOR FAN — TYPE</b>	CENTRIFUGAL	CENTRIFUGAL	CENTRIFUGAL
Dia x Width (in.)	11 X 10	11 X 10	11 X 10
Drive/No. Speeds	DIRECT / VARIABLE	DIRECT / VARIABLE	DIRECT / VARIABLE
CFM @ 0.0 in. w.g.⑤	SEE FAN PERFORMANCE TABLE	SEE FAN PERFORMANCE TABLE	SEE FAN PERFORMANCE TABLE
Motor — HP/R.P.M.	3/4 / VARIABLE	1 / VARIABLE	1 / VARIABLE
Volts/Ph/Hz	200-230/1/60	208-230/1/60	208-230/1/60
F.L. Amps/L.R. Amps	6.8 / 6.8	6.9 / 6.9	6.9 / 6.9
<b>COMBUSTION FAN — TYPE</b>	CENTRIFUGAL	CENTRIFUGAL	CENTRIFUGAL
Drive/No. Speeds	DIRECT / 2	DIRECT / 2	DIRECT / 2
Motor — HP/R.P.M.	1/45 / 2800/1500	1/20 / 3350/2600	1/45 / 2800/1500
Volts/Ph/Hz	208-230/1/60	208-230/1/60	208-230/1/60
FLA	0.34	0.34	0.34
<b>FILTER / FURNISHED</b>	NO	NO	NO
Type Recommended	THROWAWAY	THROWAWAY	THROWAWAY
Recmd. Face Area (sq. ft.)⑥	5.3	5.3	6.7
<b>REFRIGERANT</b>	R410A	R410A	R410A
Charge (lbs.)④	8.2	9.75	9.75
<b>GAS PIPE SIZE (in.)</b>	1/2	1/2	1/2
<b>DIMENSIONS</b>	H X W X L	H X W X L	H X W X L
Crated (in.)	47.86 / 47.4 / 61.75	51.86 / 47.4 / 61.75	51.86 / 47.4 / 61.75
<b>WEIGHT</b>			
Shipping (lbs.) / Net (lbs.)	659 / 531	676 / 548	676 / 548

① Certified in accordance with the Unitary Air-Conditioner Equipment certification program, which is based on AHRI Standard 210/240. Sound Power values are not adjusted for AHRI 270-95 tonal corrections.

② All models are certified to UL 1995. Ratings shown are for elevations up to 2000 ft. For higher elevations reduce ratings at a rate of 4% per 1000 ft. elevation.

③ Convertible to LPG.

④ This value is approximate. For more precise value, see Unit Nameplate.

⑤ Based on U.S. Government Standard Tests.

⑥ Filters must be installed in return air stream. Square footages listed are based on 300 f.p.m. face velocity. If permanent filters are used size per manufacturer's recommendation with a clean resistance of 0.05" W.C.

⑦ Standard Air - Dry Coil - Outdoor.



# Indoor Blower Performance

## Indoor Fan Performance 4YCY4024

### Horizontal Airflow

4YCY4024-HOR		External Static Pressure (in. wg)											
Motor Speed			0	0.1	0.2	0.3	0.4	0.5	0.6	0.7	0.8	0.9	1
LOW	Watts	52	66	89	115	140	164	186	206	229	259	300	
	CFM	706	716	727	733	731	719	700	679	662	659	682	
MED*	Watts	-	94	120	148	177	207	233	254	267	290	320	
	CFM	-	793	805	813	813	806	793	780	778	799	800	
HIGH	Watts	-	-	125	153	182	211	243	284	342	426	551	
	CFM	-	-	877	892	903	904	897	884	869	863	877	

### Down Airflow

4YCY4024-DOWN		External Static Pressure (in. wg)											
Motor Speed			0	0.1	0.2	0.3	0.4	0.5	0.6	0.7	0.8	0.9	1
LOW	Watts	35	70	90	108	131	160	188	204	240	270	320	
	CFM	695	729	734	728	721	715	705	679	675	680	685	
MED*	Watts	79	87	105	129	155	180	206	232	264	306	364	
	CFM	846	807	802	810	816	813	803	794	800	820	810	
HIGH	Watts	86	102	127	156	185	213	242	275	319	345	385	
	CFM	884	870	882	899	909	907	895	886	898	910	900	

## Indoor Fan Performance 4YCY4030

### Horizontal Airflow

4YCY4030-HOR		External Static Pressure (in. wg)											
Motor Speed			0	0.1	0.2	0.3	0.4	0.5	0.6	0.7	0.8	0.9	1
350 CFM	Watts	-	113	148	176	203	233	263	291	309	306	267	-
	CFM	-	880	905	917	918	913	906	901	907	930	979	-
400 CFM*	Watts	-	146	184	215	243	272	303	330	348	347	312	-
	CFM	-	996	1009	1013	1012	1008	1003	1000	997	994	991	-
450 CFM	Watts	-	195	233	267	303	340	371	388	373	-	-	-
	CFM	-	1122	1132	1134	1136	1138	1133	1107	1039	-	-	-

### Down Airflow

4YCY4030-DOWN		External Static Pressure (in. wg)											
Motor Speed			0	0.1	0.2	0.3	0.4	0.5	0.6	0.7	0.8	0.9	1
350 CFM	Watts	-	112	147	172	198	227	259	288	303	286	217	-
	CFM	-	871	894	898	893	884	874	864	851	828	788	-
400 CFM*	Watts	-	152	185	211	238	269	303	333	349	334	271	-
	CFM	-	990	995	992	984	974	964	955	946	937	925	-
450 CFM	Watts	-	191	227	258	289	321	355	392	432	-	-	-
	CFM	-	1090	1099	1095	1091	1091	1089	1071	1011	-	-	-

\*Factory Default Setting

# Indoor Blower Performance

## Indoor Fan Performance 4YCY4036

### Horizontal Airflow

4YCY4036-HOR		External Static Pressure (in. wg)										
Motor Speed		0	0.1	0.2	0.3	0.4	0.5	0.6	0.7	0.8	0.9	1
LOW	Watts	162	173	197	226	256	285	313	343	383	440	525
	CFM	1058	1062	1063	1063	1062	1060	1057	1053	1048	1042	1033
MED*	Watts	179	230	265	296	329	366	403	431	450	485	555
	CFM	1179	1196	1204	1206	1205	1203	1199	1194	1185	1169	1144
HIGH	Watts	318	336	365	399	435	469	502	533	563	-	-
	CFM	1390	1376	1370	1366	1361	1354	1349	1351	1369	-	-

### Down Airflow

4YCY4036-DOWN		External Static Pressure (in. wg)										
Motor Speed		0	0.1	0.2	0.3	0.4	0.5	0.6	0.7	0.8	0.9	1
LOW	Watts	169	182	210	243	273	301	331	370	433	480	530
	CFM	1025	1062	1068	1063	1060	1061	1064	1055	1015	975	990
MED*	Watts	225	253	283	315	348	381	414	449	484	522	575
	CFM	1187	1201	1203	1201	1198	1197	1194	1184	1157	1165	1150
HIGH	Watts	339	357	390	424	455	483	516	571	669	-	-
	CFM	1391	1377	1377	1375	1366	1352	1344	1360	1340	-	-

## Indoor Fan Performance 4YCY4042

### Horizontal Airflow

4YCY4042-HOR		External Static Pressure (in. wg)										
Motor Speed		0	0.1	0.2	0.3	0.4	0.5	0.6	0.7	0.8	0.9	1
350 CFM	Watts	-	160	185	214	245	277	308	339	368	396	423
	CFM	-	1206	1211	1213	1215	1215	1214	1212	1208	1201	1190
400 CFM*	Watts	-	231	261	292	325	359	394	431	467	503	536
	CFM	-	1389	1398	1405	1409	1410	1408	1403	1399	1396	1399
450 CFM	Watts	-	326	362	393	421	450	482	517	556	597	-
	CFM	-	1582	1592	1593	1587	1577	1566	1557	1553	1556	-

### Down Airflow

4YCY4042-DOWN		External Static Pressure (in. wg)										
Motor Speed		0	0.1	0.2	0.3	0.4	0.5	0.6	0.7	0.8	0.9	1
350 CFM	Watts	-	176	203	232	262	294	325	357	388	417	443
	CFM	-	1207	1214	1217	1216	1213	1208	1201	1193	1185	1177
400 CFM*	Watts	-	253	290	323	355	386	420	455	491	526	558
	CFM	-	1405	1411	1413	1412	1407	1399	1389	1377	1366	1357
450 CFM	Watts	-	367	379	409	446	485	522	556	591	633	-
	CFM	-	1599	1577	1570	1569	1566	1560	1550	1537	1528	-

\*Factory Default Setting

# Indoor Blower Performance

## Indoor Fan Performance 4YCY4048

### Horizontal Airflow

4YCY4048-HOR		External Static Pressure (in. wg)										
Motor Speed		0	0.1	0.2	0.3	0.4	0.5	0.6	0.7	0.8	0.9	1
LOW	Watts	200	220	250	285	320	354	386	417	449	487	538
	CFM	1407	1394	1396	1403	1408	1408	1402	1391	1380	1377	1392
MED*	Watts	268	316	354	386	417	448	483	520	559	597	630
	CFM	1584	1608	1616	1615	1608	1600	1593	1586	1579	1568	1550
HIGH	Watts	378	430	478	522	563	602	640	679	717	758	-
	CFM	1798	1821	1830	1833	1831	1828	1825	1822	1817	1807	-

### Down Airflow

4YCY4048-DOWN		External Static Pressure (in. wg)										
Motor Speed		0	0.1	0.2	0.3	0.4	0.5	0.6	0.7	0.8	0.9	1
LOW	Watts	141	232	270	294	329	378	431	456	478	505	545
	CFM	1344	1405	1414	1411	1416	1433	1425	1435	1430	1410	1400
MED*	Watts	253	332	379	412	443	480	524	570	607	619	583
	CFM	1582	1614	1624	1624	1621	1618	1618	1620	1618	1606	1574
HIGH	Watts	364	461	518	558	597	643	693	739	764	785	-
	CFM	1816	1829	1836	1839	1840	1840	1844	1835	1830	1825	-

## Indoor Fan Performance 4YCY4060

### Horizontal Airflow

4YCY4060-HOR		External Static Pressure (in. wg)										
Motor Speed		0	0.1	0.2	0.3	0.4	0.5	0.6	0.7	0.8	0.9	1
LOW	Watts	394	427	464	504	548	591	633	668	-	-	-
	CFM	1673	1772	1799	1793	1779	1771	1767	1756	-	-	-
MED*	Watts	695	642	660	710	764	811	849	893	966	1108	-
	CFM	2054	2036	2031	2032	2033	2031	2023	2012	2002	2000	-

### Down Airflow

4YCY4060-DOWN		External Static Pressure (in. wg)										
Motor Speed		0	0.1	0.2	0.3	0.4	0.5	0.6	0.7	0.8	0.9	1
LOW	Watts	443	461	493	532	571	607	642	680	-	-	-
	CFM	1796	1741	1726	1725	1722	1712	1698	1692	-	-	-
MED*	Watts	740	697	715	763	819	866	892	894	872	835	-
	CFM	2010	1987	1979	1977	1976	1969	1950	1913	1852	1759	-

\*Factory Default Setting

# Indoor Blower Performance

Heating Airflow, horizontal or downflow from .2 to .6" wg.

4YCY4024C1060				
Switch Settings		Selection	Nominal Airflow	
			Low Stage	High Stage
7-OFF	8-OFF	A	600	850
7-ON	8-OFF	B	625	900
7-OFF	8-ON	C	650	925
7-ON	8-ON	D	700	975

4YCY4042				
Switch Settings		Selection	Nominal Airflow	
			Low Stage	High Stage
7-OFF	8-OFF	A	1075	1375
7-ON	8-OFF	B	1100	1450
7-OFF	8-ON	C	1150	1500
7-ON	8-ON	D	1200	1575

4YCY4030				
Switch Settings		Selection	Nominal Airflow	
			Low Stage	High Stage
7-OFF	8-OFF	A	725	1000
7-ON	8-OFF	B	775	1075
7-OFF	8-ON	C	850	1150
7-ON	8-ON	D	925	1250

4YCY4048C*090				
Switch Settings		Selection	Nominal Airflow	
			Low Stage	High Stage
7-OFF	8-OFF	A	1075	1375
7-ON	8-OFF	B	1100	1450
7-OFF	8-ON	C	1150	1500
7-ON	8-ON	D	1200	1575

\* can be 1 or 3

4YCY4036C *070				
Switch Settings		Selection	Nominal Airflow	
			Low Stage	High Stage
7-OFF	8-OFF	A	725	1000
7-ON	8-OFF	B	775	1075
7-OFF	8-ON	C	850	1150
7-ON	8-ON	D	925	1250

\* can be 1 or 3

4YCY4048C*115				
Switch Settings		Selection	Nominal Airflow	
			Low Stage	High Stage
7-OFF	8-OFF	A	1050	1500
7-ON	8-OFF	B	1100	1575
7-OFF	8-ON	C	1150	1625
7-ON	8-ON	D	1200	1700

\* can be 1 or 3

4YCY4036C *090				
Switch Settings		Selection	Nominal Airflow	
			Low Stage	High Stage
7-OFF	8-OFF	A	825	1100
7-ON	8-OFF	B	875	1175
7-OFF	8-ON	C	950	1275
7-ON	8-ON	D	1025	1375

\* can be 1 or 3

4YCY4060				
Switch Settings		Selection	Nominal Airflow	
			Low Stage	High Stage
7-OFF	8-OFF	A	1375	1800
7-ON	8-OFF	B	1450	1900
7-OFF	8-ON	C	1525	1975
7-ON	8-ON	D	1575	2075

# Typical Field Wiring

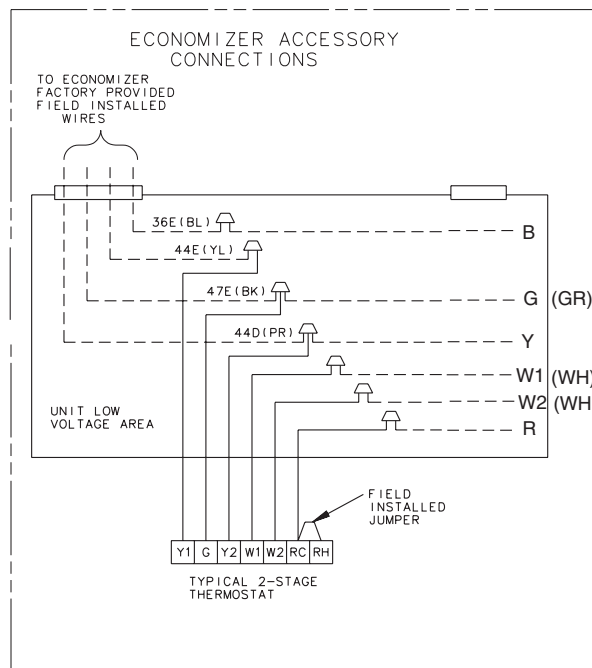
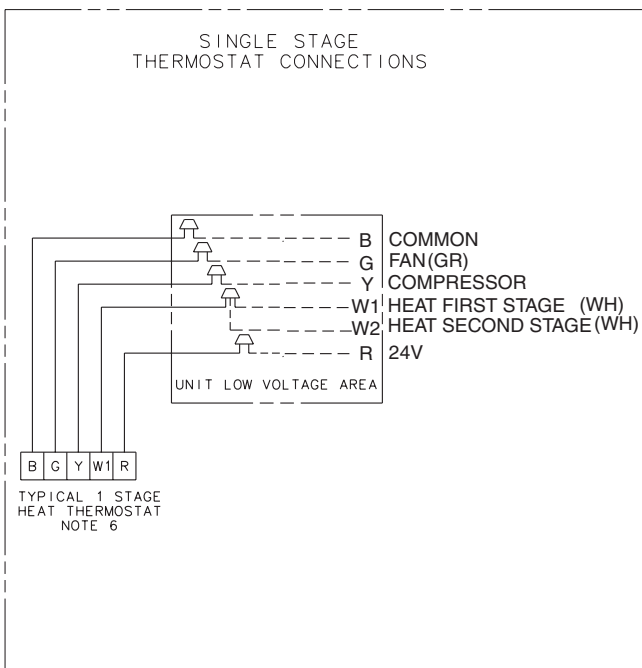
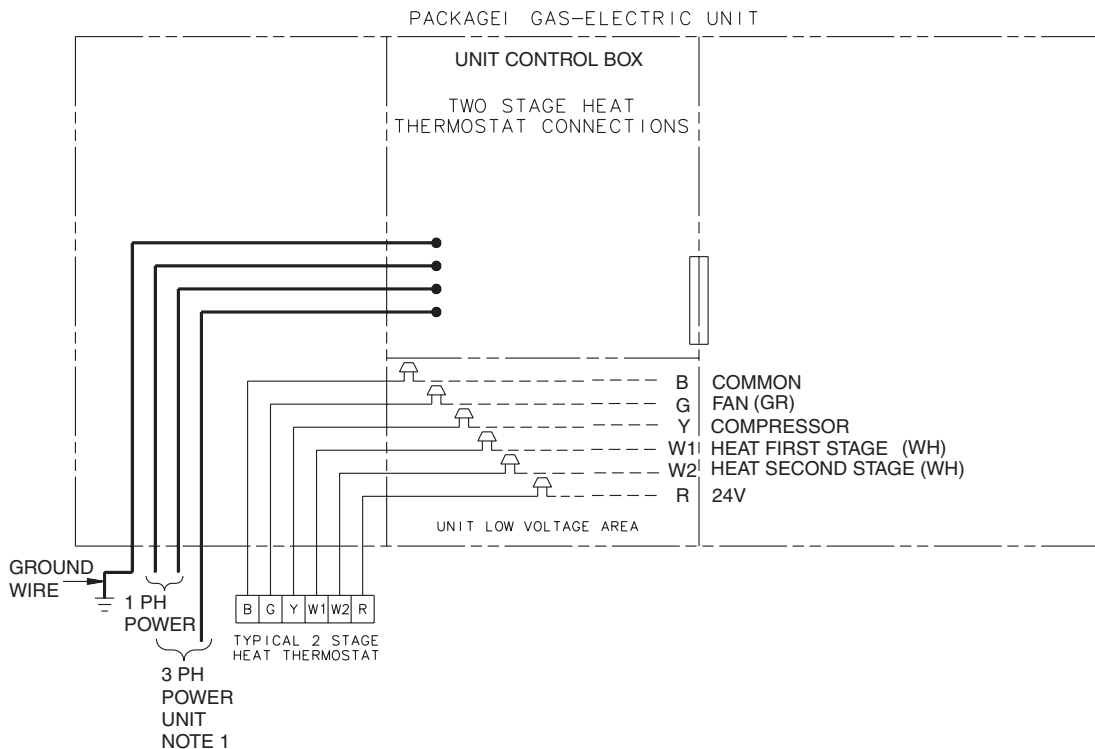

**NOTES:**

1. FUSED DISCONNECT SIZE, POWER WIRING AND GROUNDING OF EQUIPMENT MUST COMPLY WITH CODES.
2. BE SURE POWER SUPPLY AGREES WITH EQUIPMENT AND HEATER NAMEPLATE.
3. LOW VOLTAGE WIRING TO BE 18 AWG MINIMUM CONDUCTOR.
4. SEE UNIT DIAGRAM FOR ELECTRICAL CONNECTION DETAILS.
5. THE THERMOSTAT ON THE GAS/ELECTRIC UNIT MUST PROVIDE A 'G' SIGNAL IN THE COOLING MODE ONLY. DURING THE HEATING MODE THE FAN WILL BE ENERGIZED BY THE SYSTEM.
6. FOR SINGLE STAGE THERMOSTATS JUMPER W1 AND W2 TOGETHER. SECOND STAGE HEAT WILL BEGIN 10 MINUTES AFTER FIRST STAGE.

**INTER-COMPONENT WIRING**

- 24V. } FACTORY WIRING  
 ----- LINE V. }  
 ----- 24V. } FIELD WIRING  
 ----- LINE V. }

WIRE COLOR DESIGNATION			
ABBR	COLOR	ABBR	COLOR
BK	BLACK	PR	PURPLE
BL	BLUE	RD	RED
BR	BROWN	WH	WHITE
GR	GREEN	YL	YELLOW
OR	ORANGE		

# Typical Wiring

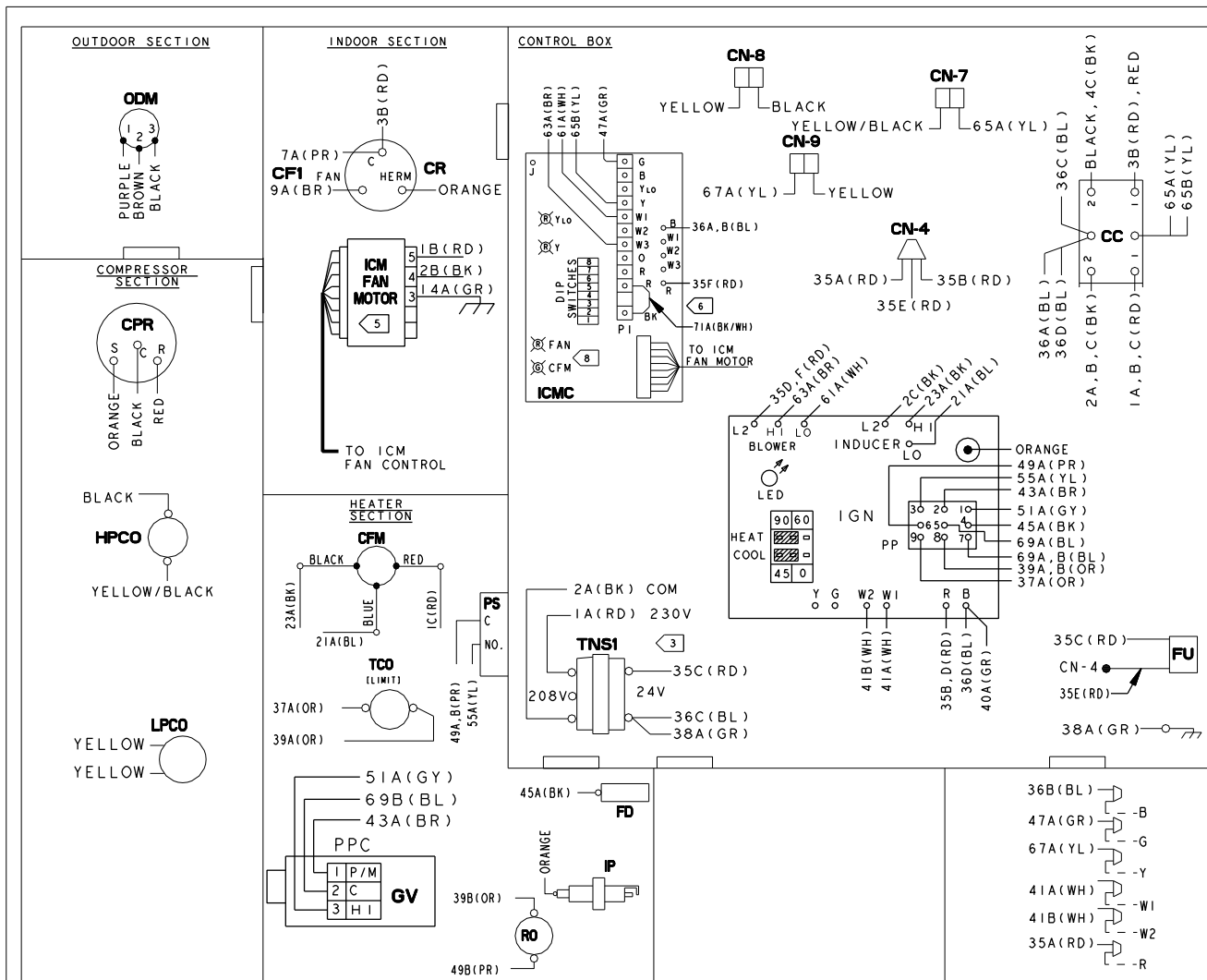

**NOTES:**

1. CONNECTIONS SHOWN ARE FOR A TYPICAL THERMOSTAT. SEE SCHEMATIC SUPPLIED WITH THERMOSTAT FOR PROPER CONNECTIONS. LOW VOLTAGE WIRING TO UNIT MAY BE NEC CLASS 2 AND MUST BE A MIN. OF 18 A. W.G. SET THERMOSTAT HEAT ANTICIPATOR TO .3 AMPS.
2. MAXIMUM ADDITIONAL EXTERNAL LOAD (PILOT DUTY) BETWEEN "B" AND "R" OF 0.5 AMPS, 24 VAC IS AVAILABLE IN THE COOLING MODE ONLY.
3. FOR 208 VOLT OPERATION MAKE THE FOLLOWING WIRING CHANGES:  
A: AT TNS1 REMOVE 1A(RD) WIRE AND CONNECT TO 208V TERMINAL ON TRANSFORMER.
4. IF ANY OF THE ORIGINAL WIRE AS SUPPLIED IN THIS UNIT MUST BE REPLACED, REPLACE IT WITH APPLIANCE WIRING MAT'L RATED AT 105° C.
5. "T" TERMINAL IS NOT CONNECTED WHEN AN ELECTRONIC THERMOSTAT IS USED.
6. IF OPTIONAL HUMIDISTAT ACCESSORY IS USED, ON THE ICMC BOARD CUT THE 71A(BK/WH) JUMPER AND CONNECT THE HUMIDISTAT BETWEEN TERMINALS.

WIRE COLOR DESIGNATION	ABBV	COLOR	ABBV	COLOR
BK	BLACK	PR	PURPLE	
BL	BLUE	RD	RED	
BR	BROWN	WH	WHITE	
GR	GREEN	YL	YELLOW	
OR	ORANGE			

**ICMC DIP SWITCH SETTINGS**

DIP SWITCH SETTINGS				COOLING/ HEAT PUMP CFM	NOMINAL AIRFLOW
SW 1	SW 2	SW 3	SW 4		
OFF	OFF	OFF	ON	350 CFM/TON	
OFF	OFF	OFF	OFF	400 CFM/TON	**
OFF	OFF	ON	OFF	450 CFM/TON	
ON	ON	OFF	OFF	RATED CFM/TON	
FAN OFF-DELAY OPTIONS					
SW 5	SW 6			NONE	NOMINAL
OFF	OFF			45 SECONDS	100% NOMINAL**
OFF	ON			90 SECONDS	50% NOMINAL
ON	ON			ENHANCED	ENHANCED
ELECTRIC HEAT AIRFLOW					
SW 7	SW 8			350 CFM/TON	
OFF	OFF			400 CFM/TON	**

\*\* FACTORY SETTING.  
AT CONTINUOUS FAN SETTING ("G" ONLY) AIRFLOW VALUES ARE APPROXIMATELY 50% OF LISTED VALUE. THE HEAT PUMP FAN OFF-DELAY IS THE SAME AS THE COOLING MODE.

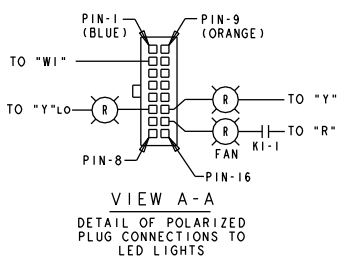

DEVICE	DESCRIPTION	LINE
CC	COMPRESSOR CONTACTOR COIL	50
CFI	OUTDOOR FAN CAPACITOR	15
CN	CONNECTOR OR WIRE NUT	
CFM	COMBUSTION FAN MOTOR	24
CPR	COMPRESSOR	14
CR	COMPRESSOR RUN CAPACITOR	14
FD	FLAME DETECTOR	37
RO	ROLLOUT LIMIT	34
GV	GAS VALVE	31
IDM	INDOOR FAN MOTOR	24
IGN	IGNITION CONTROL MODULE	27, 40
IOL	INTERNAL OVERLOAD	14
IP	IGNITOR PROBE	38
LED	IGN DIAGNOSTICS INDICATOR	34
ODM	OUTDOOR FAN MOTOR	20
PP	POLARIZED PLUG	31-37
PS	PRESSURE SWITCH	34
TCO	TEMPERATURE LIMIT SWITCH	34
TNS1	CONTROL POWER TRANSFORMER	28
FU	FUSE	33
HPCO	HIGH PRESSURE SWITCH	50
LPCO	LOW PRESSURE SWITCH	50

# Typical Wiring

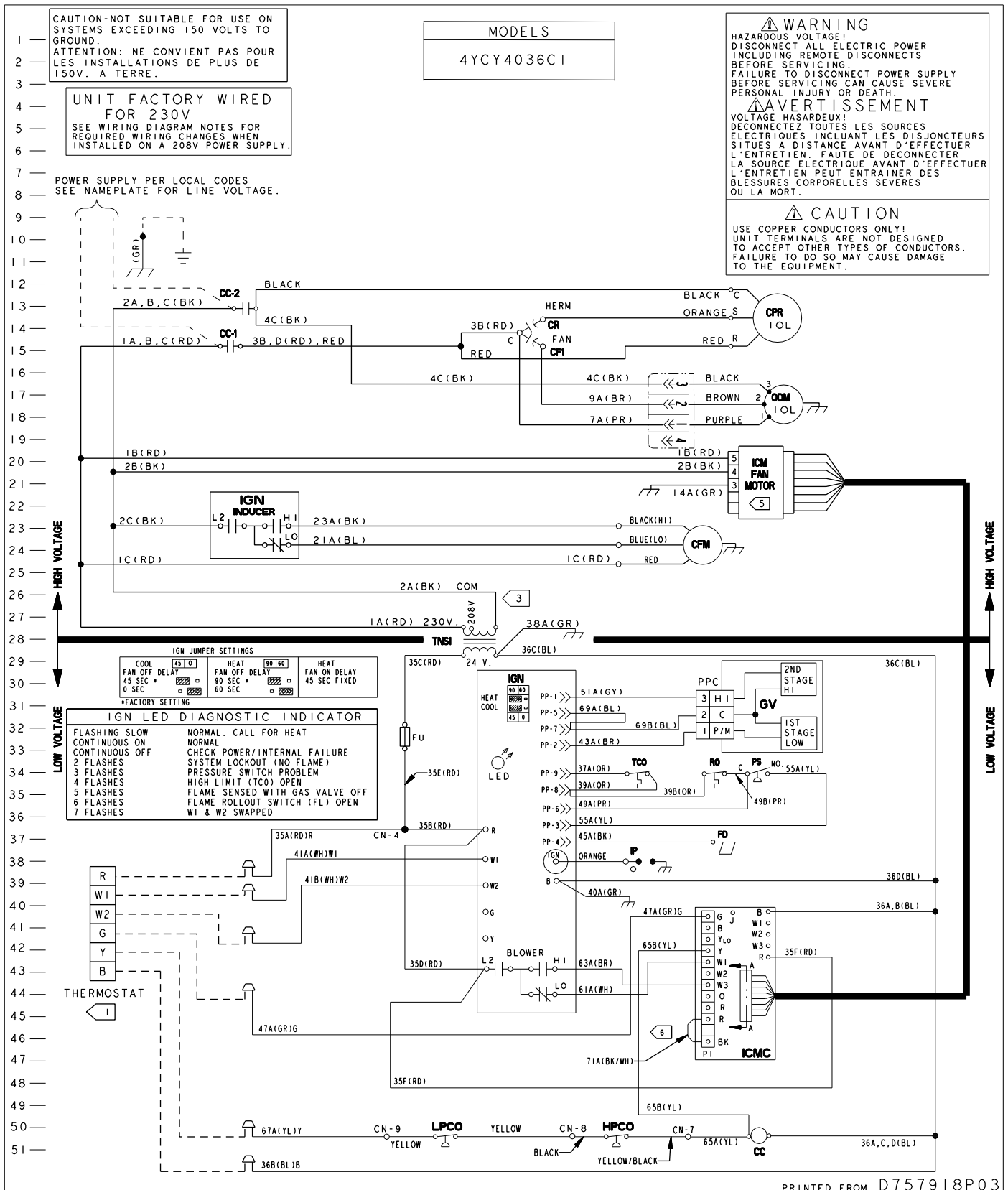



# Optional Equipment

## BAYCURB050A Full Perimeter Roof Mounting Curb for \*\*\*\*\*018-036

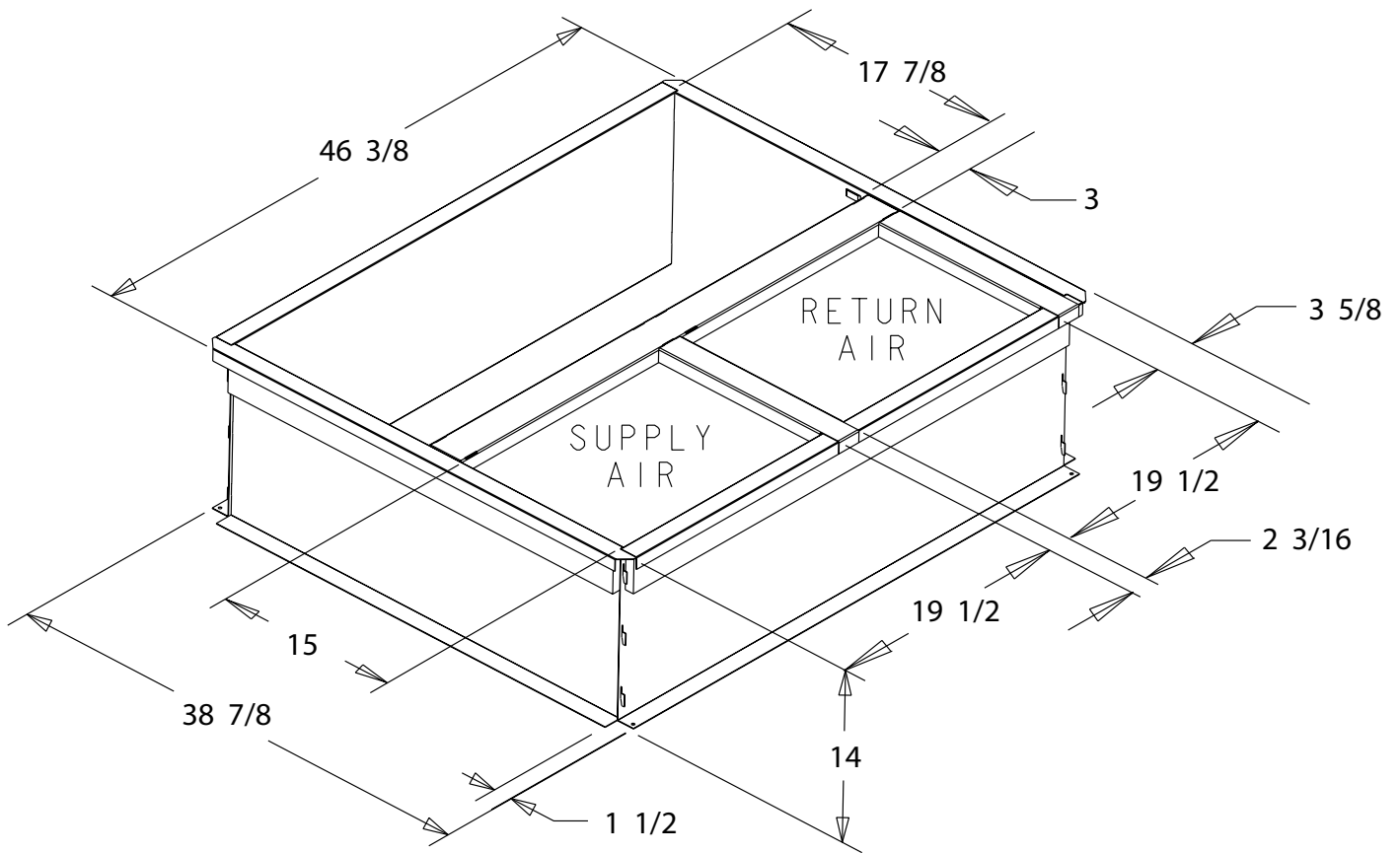

The drawings on this page are prepared by the manufacturer in order to provide detail regarding job layout only. These drawings are not intended to be used as a basis to construct, build or modify the items depicted in the drawings. The manufacturer is not responsible for the unauthorized use of these drawings and expressly disclaims any liability for damages resulting from such unauthorized use.

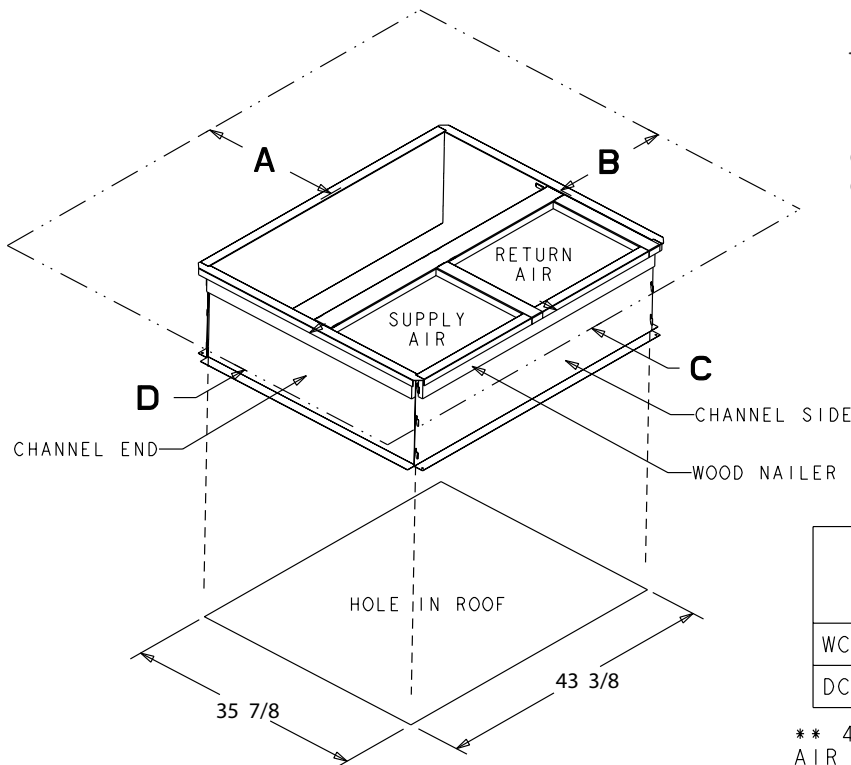

	SERVICE CLEARANCE DIMENSIONS			
	A	B	C	D
WC*/TC*	42.00	36.00	12.00**	24.00
DC*/YC*	42.00	36.00	12.00**	36.00

\*\* 42.00 WITH ECONOMIZER WITH 25% FRESH AIR ACCESSORY

# Optional Equipment

## BAYCURB051A Full Perimeter Roof Mounting Curb for \*\*\*\*\*042-060

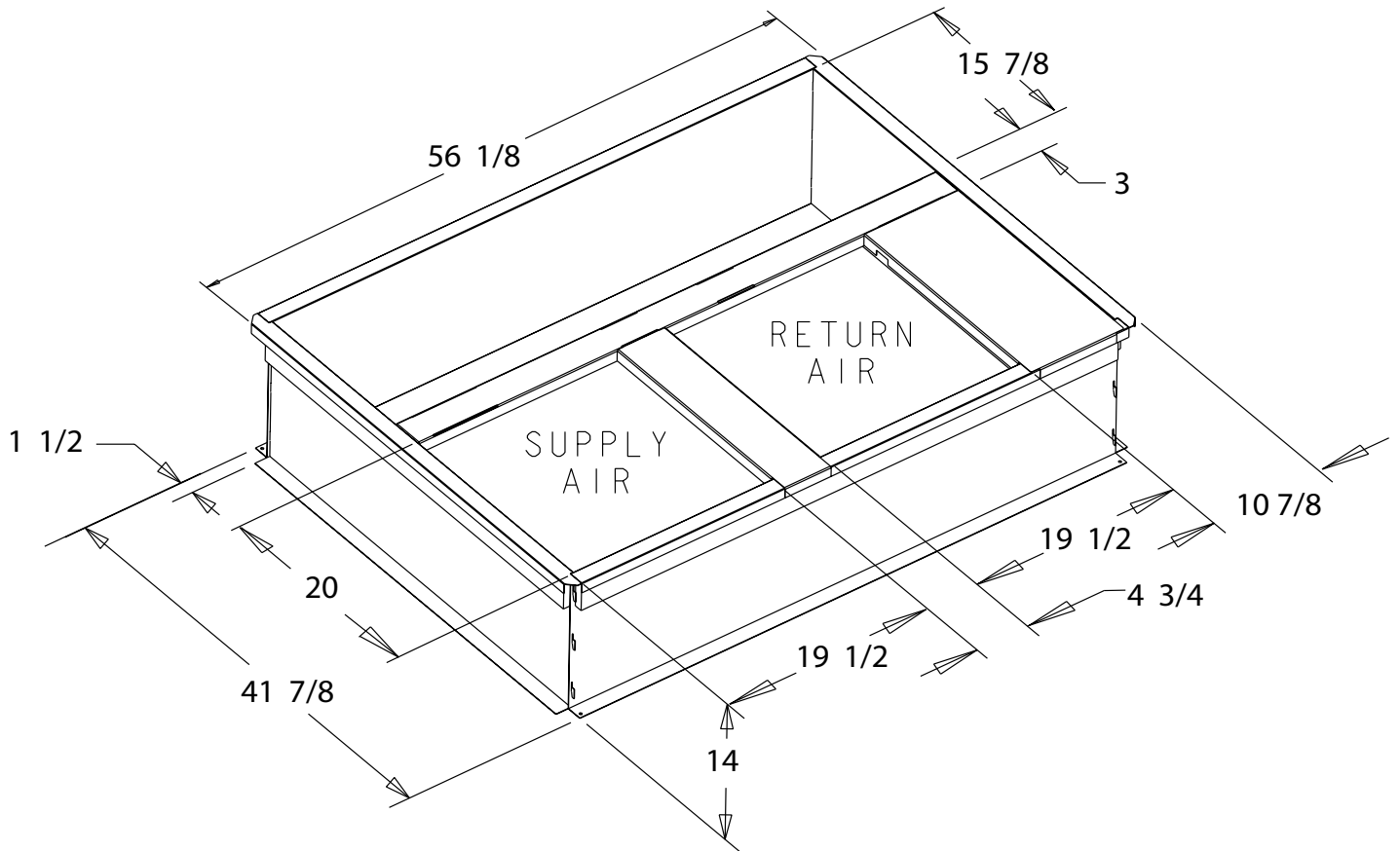

The drawings on this page are prepared by the manufacturer in order to provide detail regarding job layout only. These drawings are not intended to be used as a basis to construct, build or modify the items depicted in the drawings. The manufacturer is not responsible for the unauthorized use of these drawings and expressly disclaims any liability for damages resulting from such unauthorized use.

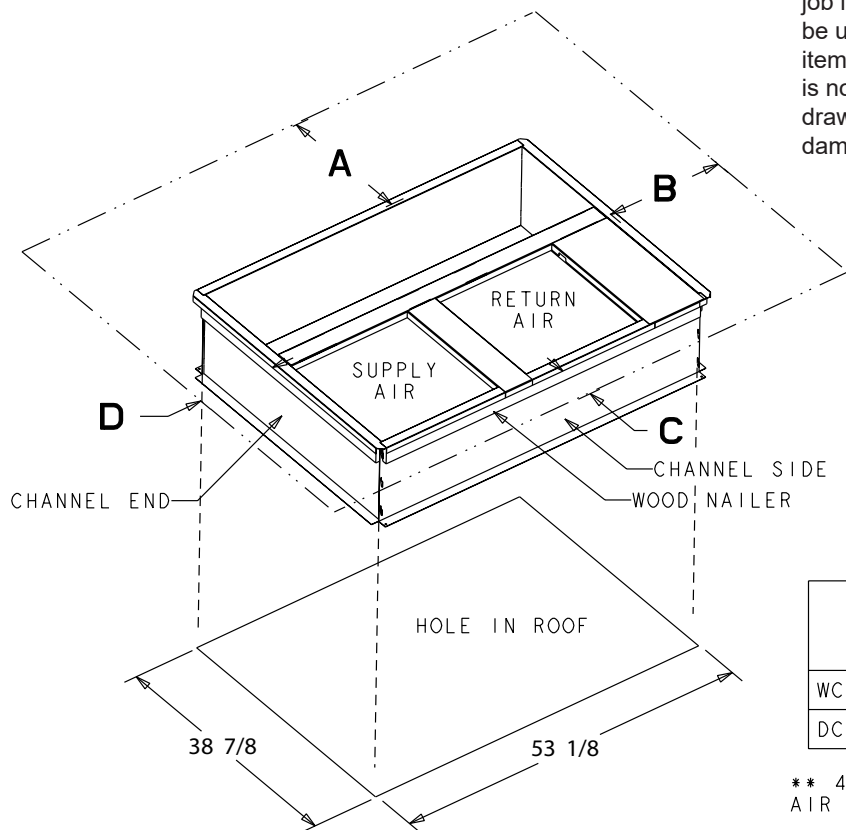

	SERVICE CLEARANCE DIMENSIONS			
	A	B	C	D
WC*/TC*	42.00	36.00	12.00**	24.00
DC*/YC*	42.00	36.00	12.00**	36.00

\*\* 42.00 WITH ECONOMIZER WITH 25% FRESH AIR ACCESSORY

# Optional Equipment

## BAYFLTR101, 201B, 1" - 2" Filter Rack (Mounts in Filter/Coil Section)

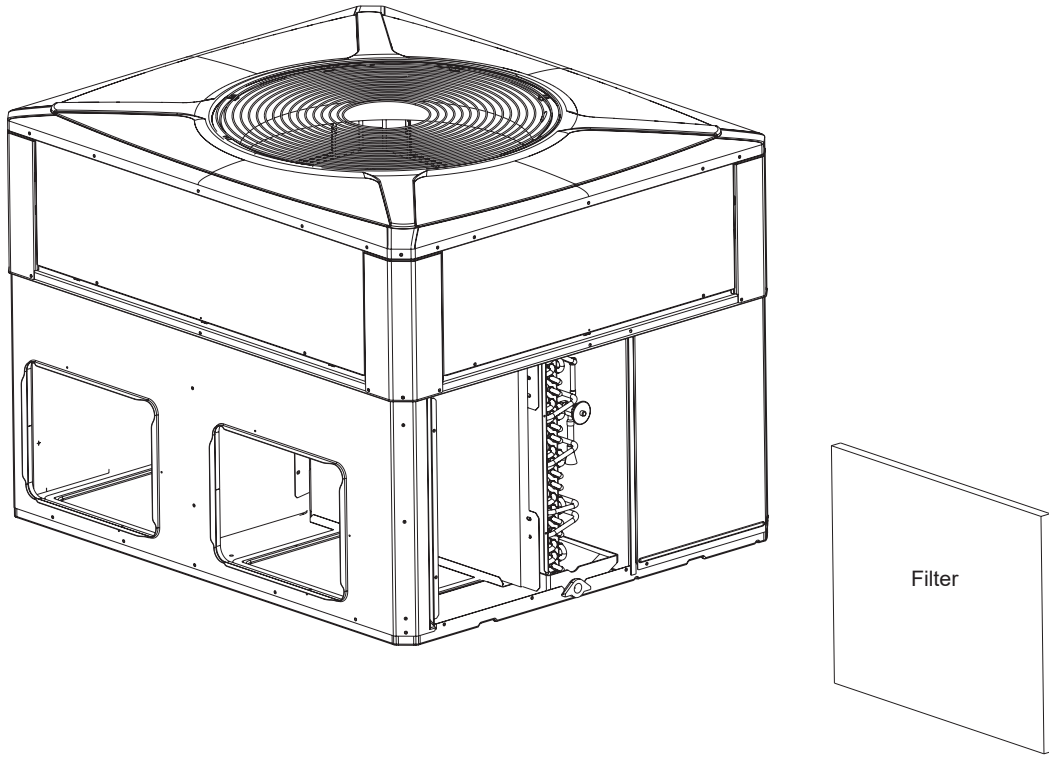

## BAYACCDOR1A & BAYACCDOR2A Hinged Filter Access Door Replaces Filter/Coil Access Panel

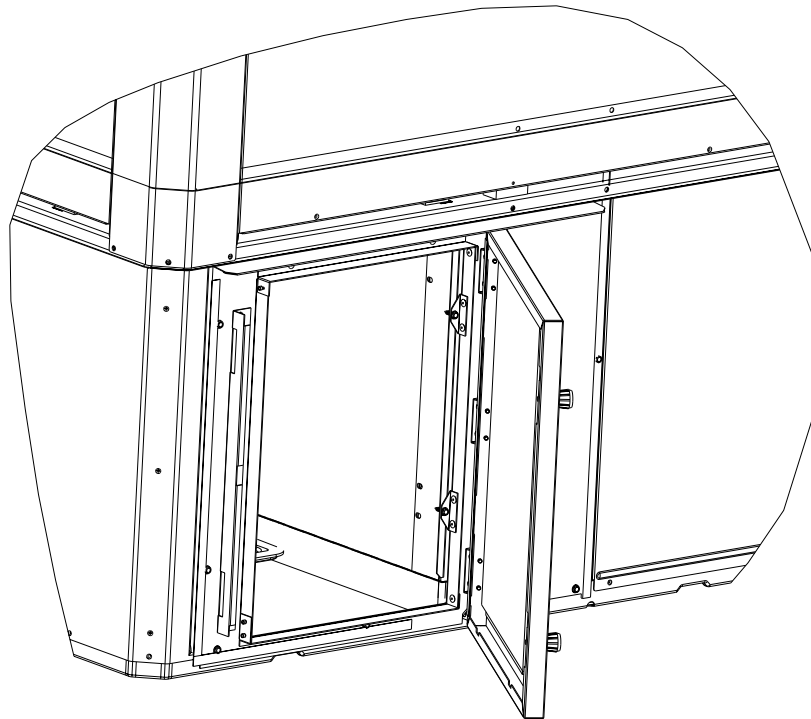

The drawings on this page are prepared by the manufacturer in order to provide detail regarding job layout only. These drawings are not intended to be used as a basis to construct, build or modify the items depicted in the drawings. The manufacturer is not responsible for the unauthorized use of these drawings and expressly disclaims any liability for damages resulting from such unauthorized use.

# Optional Equipment

## BAYECON101,102A Down Discharge Economizer and Rain Hood (Mounts Over Horizontal Return Air Opening)

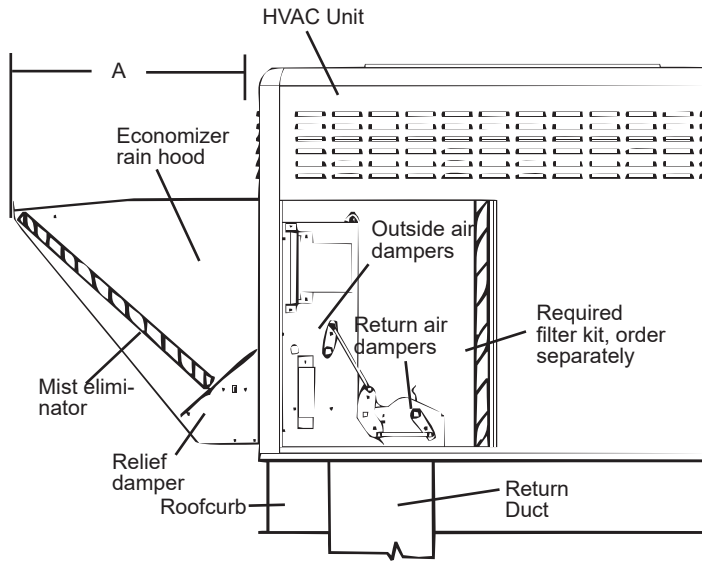

Economizer	Unit Application Models	A
BAYECON101A	4TC*,WC*,YC*,DC*	20.125"
	*018-036	
BAYECON102A	4TC*,WC*,YC*,DC*	24.375"
	*042-060	

## BAYECON200,201A Horizontal Economizer and Rain Hood

The drawings on this page are prepared by the manufacturer in order to provide detail regarding job layout only. These drawings are not intended to be used as a basis to construct, build or modify the items depicted in the drawings. The manufacturer is not responsible for the unauthorized use of these drawings and expressly disclaims any liability for damages resulting from such unauthorized use.

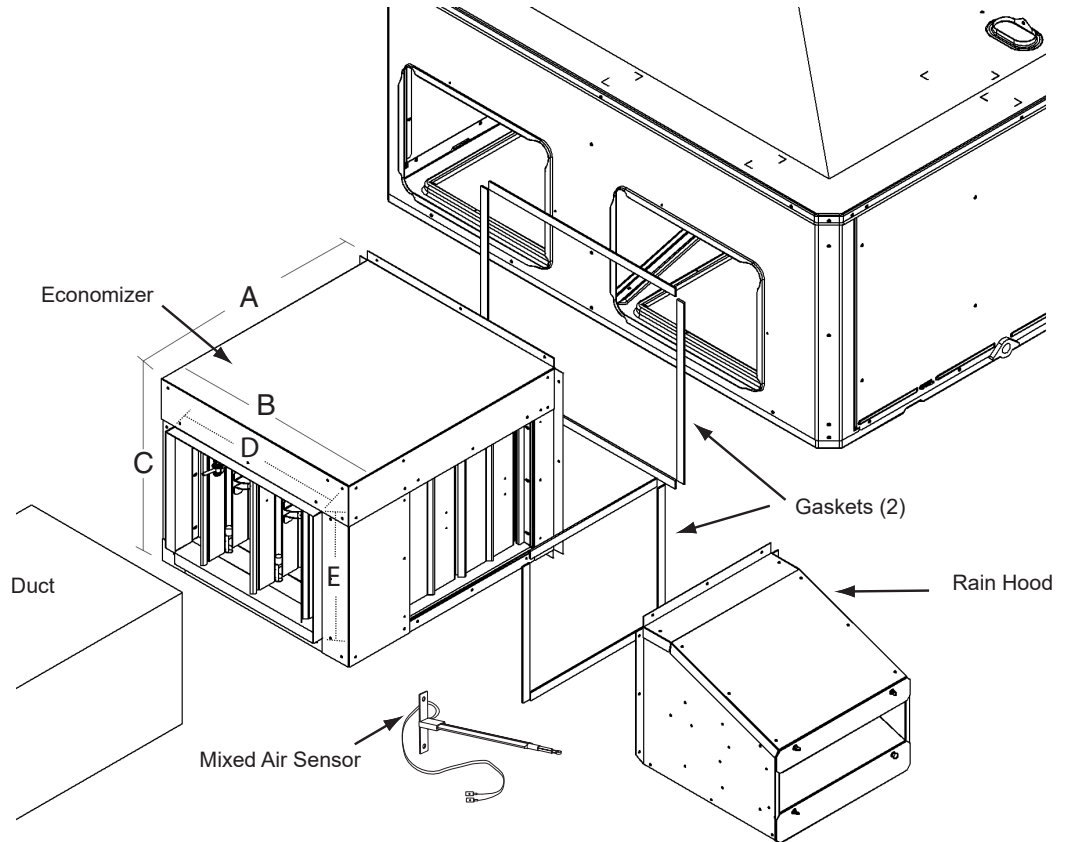

Economizer	A	B	C	D	E	F
BAYECON200AA	22"	20"	16-7/8"	15-11/16"	11-11/16"	15"
BAYECON201AA	26"	22-21/32"	19"	17-11/16"	14-11/16"	21-3/8"

# Optional Equipment

## BAYOSAH001,002A, 25% Outside Air Damper (Replaces Filter/Coil Access Panel)

The drawings on this page are prepared by the manufacturer in order to provide detail regarding job layout only. These drawings are not intended to be used as a basis to construct, build or modify the items depicted in the drawings. The manufacturer is not responsible for the unauthorized use of these drawings and expressly disclaims any liability for damages resulting from such unauthorized use.

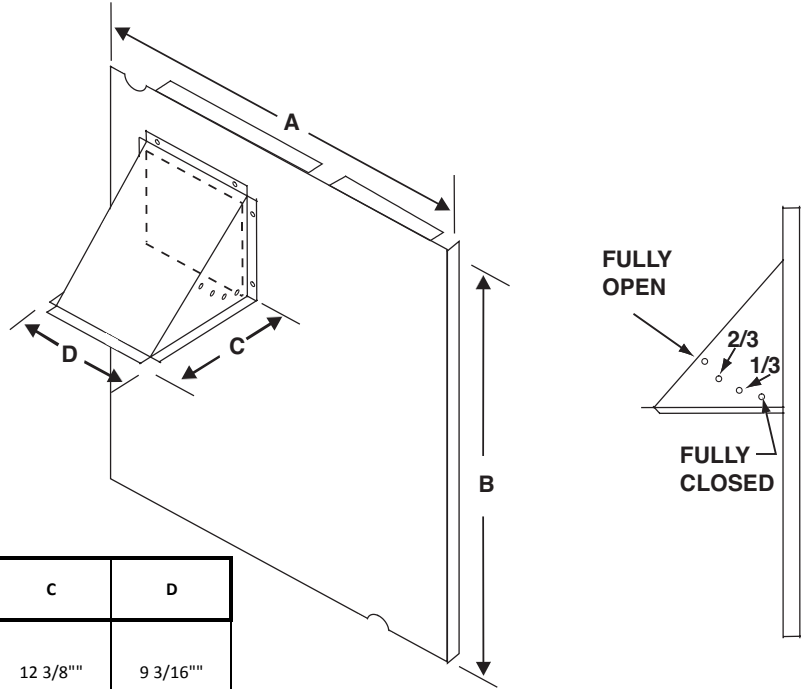

Manual Fresh Air Model	Unit Application Models	A	B	C	D
BAYOSAH001	2.0 - 3.0 Ton Models	22 7/16"	20 11/16"	12 3/8"	9 3/16"
BAYOSAH002	3.5 - 5.0 Ton Models	25 3/16"	20 11/16"	12 3/8"	9 3/16"

## BAYDMPR101,102A, 25% Motorized Outside Air Damper (Mounts Over Horizontal Return Air Opening)

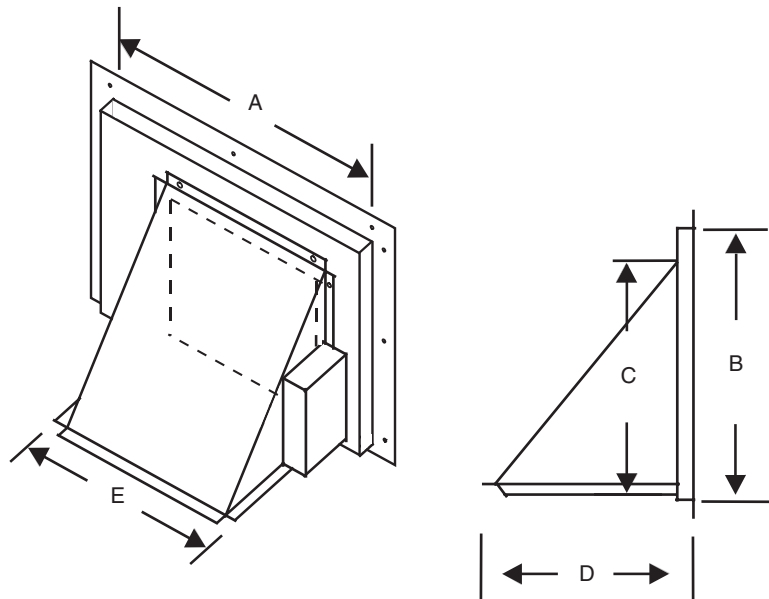

	Unit Application Models	A	B	C	D	E
BAYDMPR101A	4YC,WC3018-036 4TC*3018-036, 4W/T/Y/DCY4024-036, 4W/Y/DCZ6036	15 13/16"	11 13/16"	10 1/4"	11 1/2"	12 1/4"
BAYDMPR102A	4YC,WC3042-060, 4TC*3042-060, 4W/T/Y/DCY4042-060, 4W/Y/DCZ6048-060	18 3/16"	15 1/8"	10 1/4"	11 1/2"	12 1/4"

# Dimensional Data

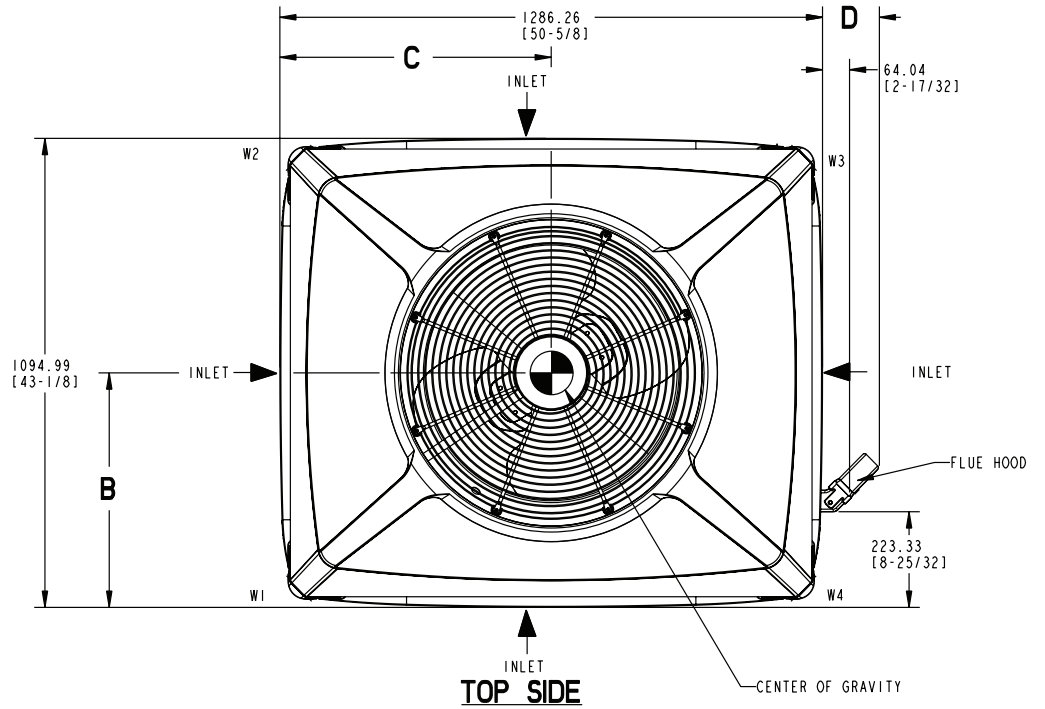

TOP SIDE

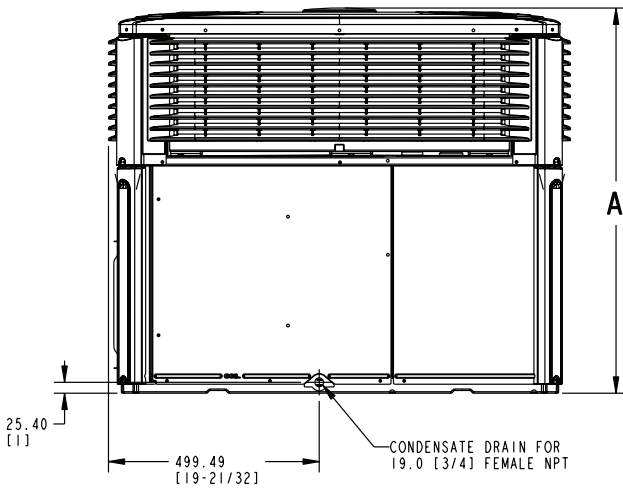

LEFT SIDE

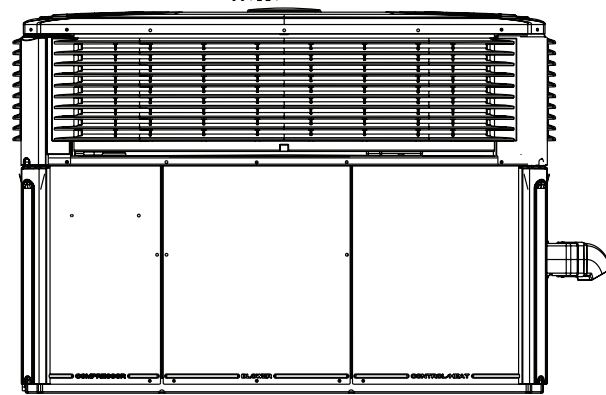

FRONT SIDE

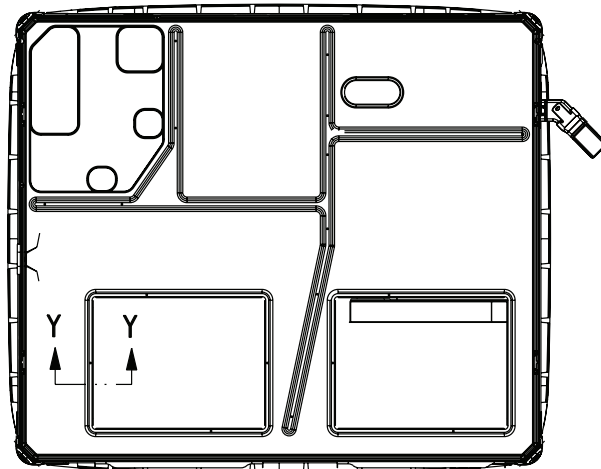
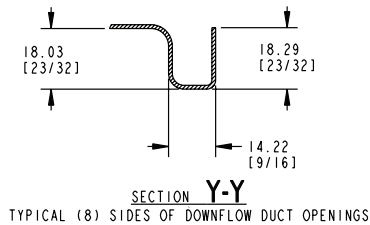

BOTTOM SIDE

4CY4024 through 4CY4036 (1 of 3)

# Dimensional Data

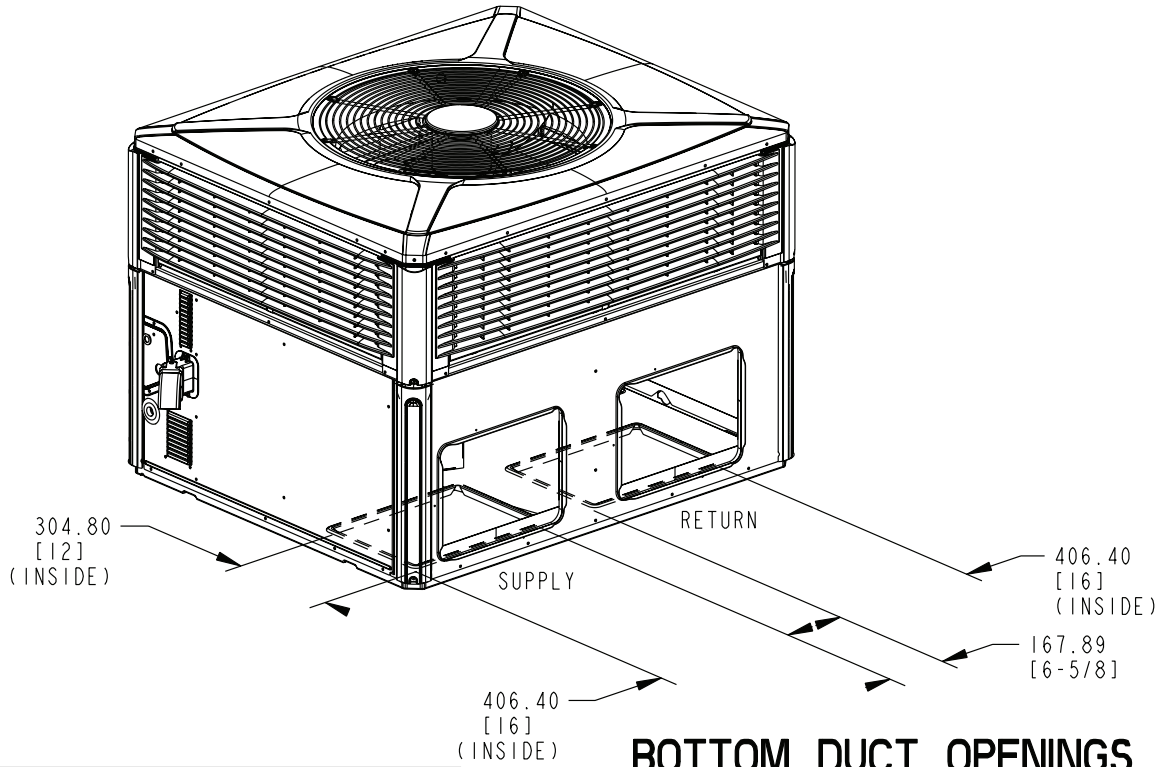

## BOTTOM DUCT OPENINGS

RECOMMENDED SERVICE CLEARANCE MM/IN.		
		WITH ECONOMIZER
BACK SIDE	304.8 [12]	762.0 [30]
LEFT SIDE	762.0 [30]	914.4 [36]
RIGHT SIDE	914.4 [36]	-
FRONT SIDE	1066.8 [42]	-

CLEARANCE TO COMBUSTIBLE MATERIAL MM/IN.	
BOTTOM	0
BACK SIDE	25.4 [1]
LEFT SIDE	152.4 [6]
RIGHT SIDE	304.8 [12]
FRONT SIDE	304.8 [12]
TOP	914.4 [36]

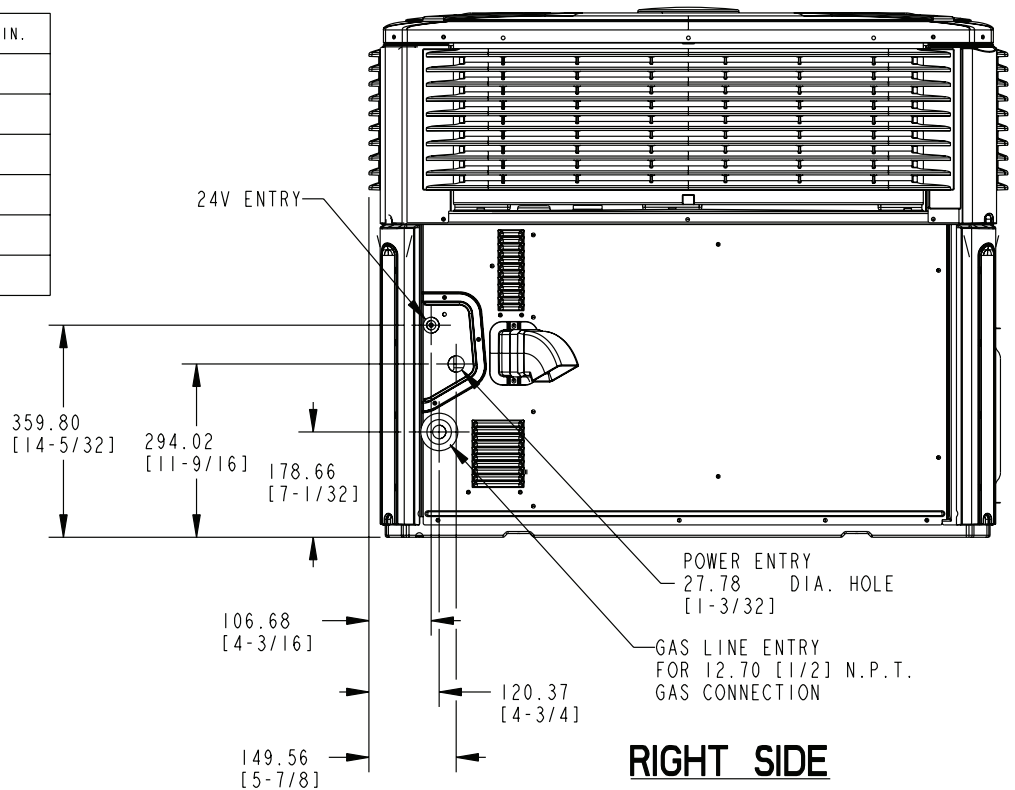

4CY4024 through 4CY4036 (2 of 3)



# Dimensional Data

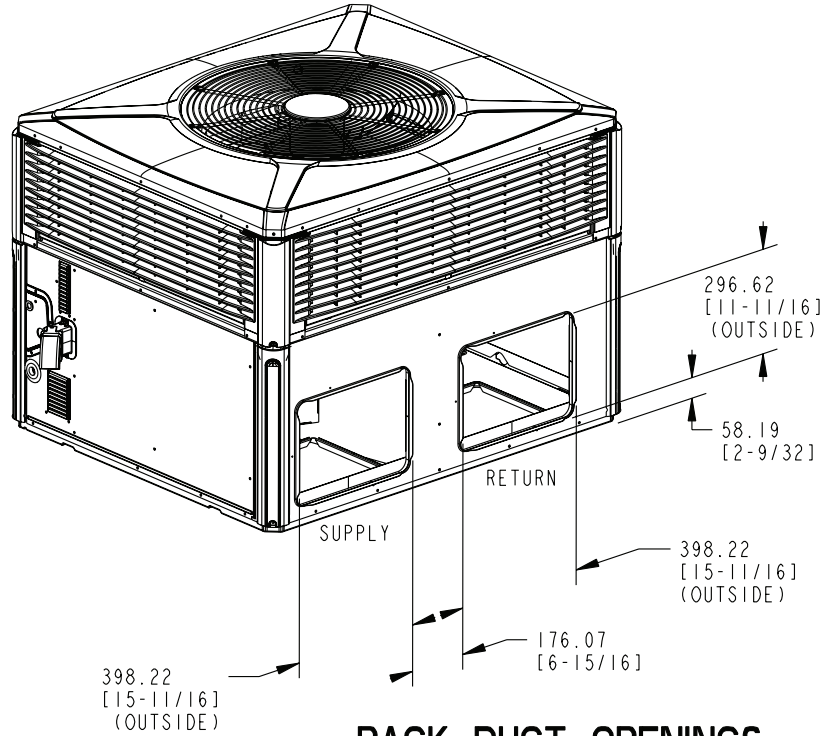

## BACK DUCT OPENINGS

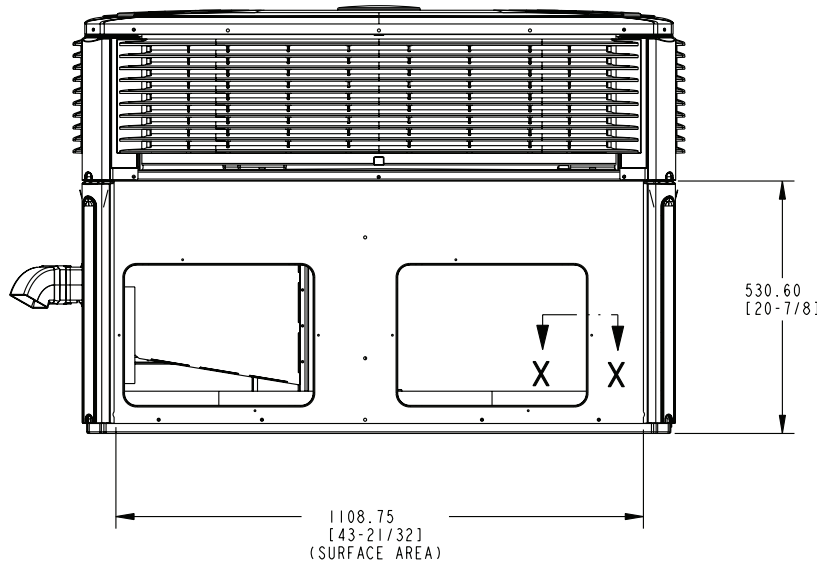

## BACK SIDE

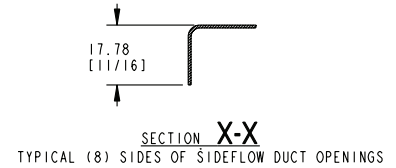

MODEL	HEIGHT MM/IN.	FLUE HOOD W/BRKT MM/IN.	APPROX. CORNER WEIGHT - KG/LBS				SHIPPING WEIGHT KG/LBS	TOTAL UNIT WEIGHT KG/LBS	CENTER OF GRAVITY MM/IN.	
	A		D	W1	W2	W3			W4	B
4CY4024 (060)	903.29 [35-9/16]	-	59.0 [130]	37.2 [82]	31.3 [69]	48.5 [107]	218.4 (481)	174.8 [385]	401.3 [15.8]	546.1 [21.5]
4CY4030 (070)		-	60.3 [133]	36.3 [80]	30.4 [67]	50.3 [111]	221.6 (488)	178.0 [392]	388.6 [15.3]	558.8 [22.0]
4CY4036/4YC26036 (070)	949.99 [37-3/8]	117.86 [4-5/8]	61.2 [135]	36.7 [81]	30.8 [68]	51.3 [113]	223.8 (493)	180.1 [397]	388.6 [15.3]	558.8 [22.0]
4CY4036/4YC26036 (090)			60.8 [134]	38.1 [84]	31.3 [69]	48.5 [107]	218.4 (481)	174.8 [385]	398.8 [15.7]	546.1 [21.5]
4DCY4024 (060)	903.29 [35-9/16]	-	59.0 [130]	37.2 [82]	31.3 [69]	48.5 [107]	218.4 (481)	174.8 [385]	401.3 [15.8]	546.1 [21.5]
4DCY4030 (070)		-	60.3 [133]	36.3 [80]	30.4 [67]	50.3 [111]	221.6 (488)	178.0 [392]	388.6 [15.3]	558.8 [22.0]
4DCY4036/4DC26036 (070)	949.99 [37-3/8]	117.86 [4-5/8]	62.1 [137]	37.2 [82]	30.4 [67]	50.3 [111]	221.6 (488)	178.0 [392]	386.1 [15.2]	558.8 [22.0]

4CY4024 through 4CY4036 (3 of 3)

# Dimensional Data

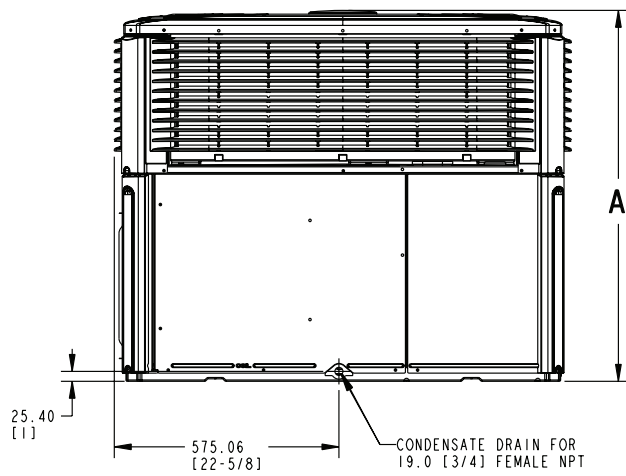
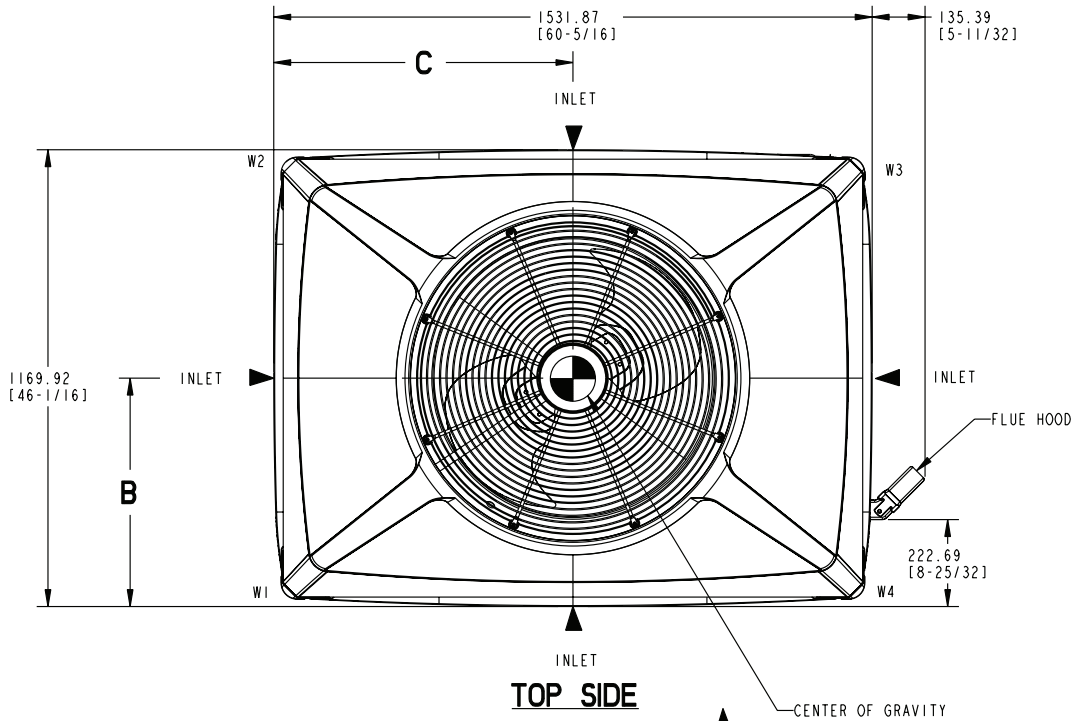

LEFT SIDE

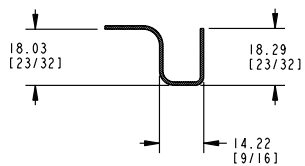
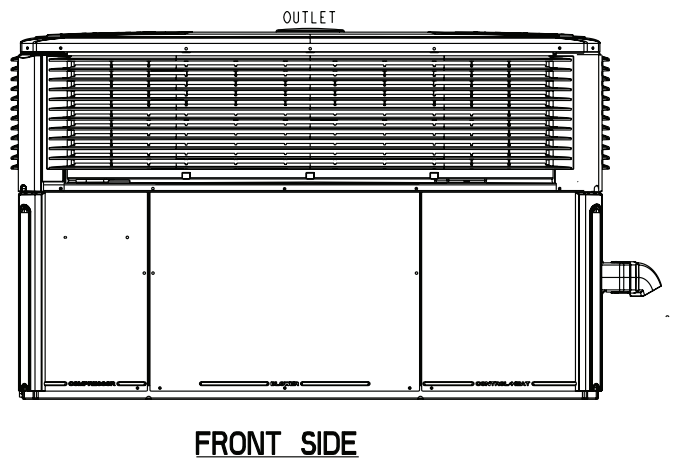

SECTION Y-Y  
 TYPICAL (8) SIDES OF DOWNFLOW DUCT OPENINGS

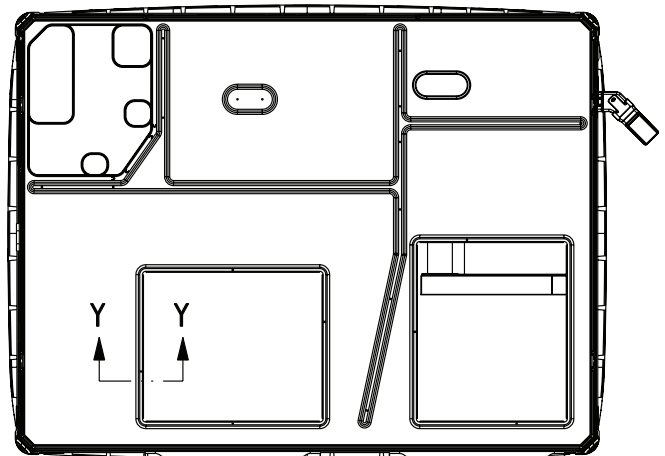

4YCY4042 through 4YCY4060 (1 of 3)

# Dimensional Data

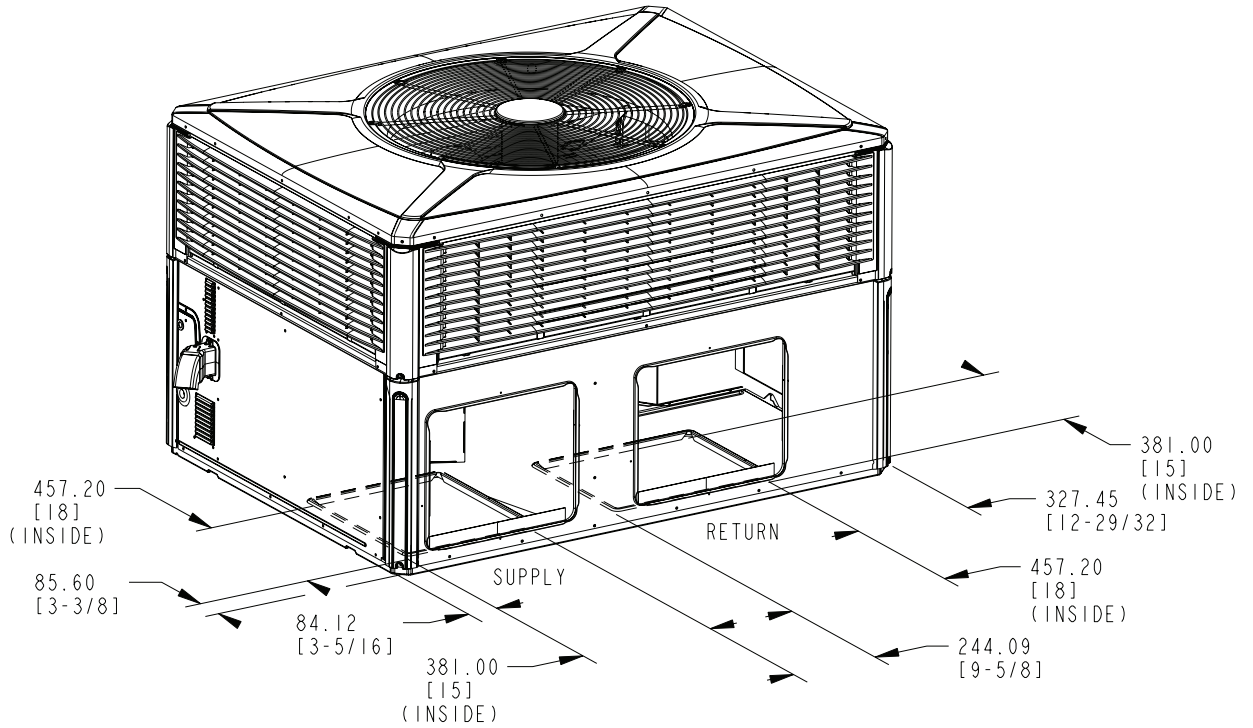

## BOTTOM DUCT OPENINGS

RECOMMENDED SERVICE CLEARANCE MM/IN.		
		WITH O.A. DAMPER/ECON.
BACK SIDE	304.8 [12]	762.0 [30]
LEFT SIDE	914.4 [36]	1066.8 [42]
RIGHT SIDE	914.4 [36]	-
FRONT SIDE	1066.8 [42]	-

CLEARANCE TO COMBUSTIBLE MATERIAL MM/IN.	
BOTTOM	0
BACK SIDE	25.4 [1]
LEFT SIDE	152.4 [6]
RIGHT SIDE	304.8 [12]
FRONT SIDE	304.8 [12]
TOP	914.4 [36]

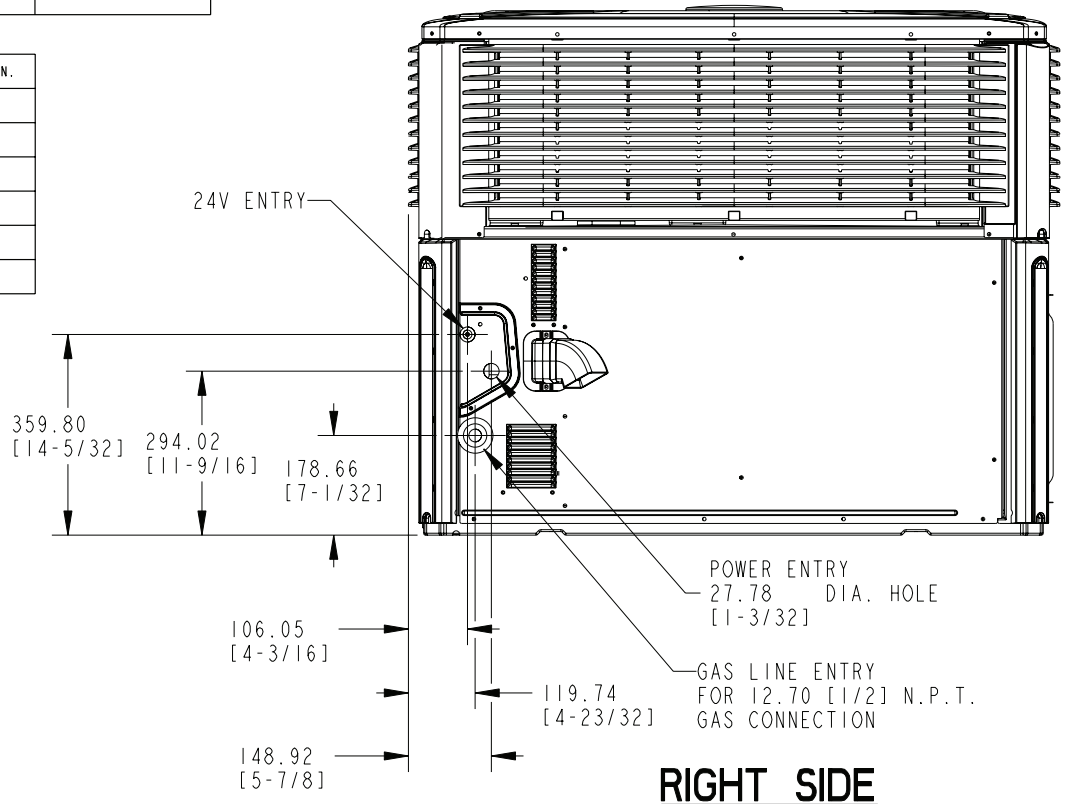

## RIGHT SIDE

4CY4042 through 4CY4060 (2 of 3)

# Dimensional Data

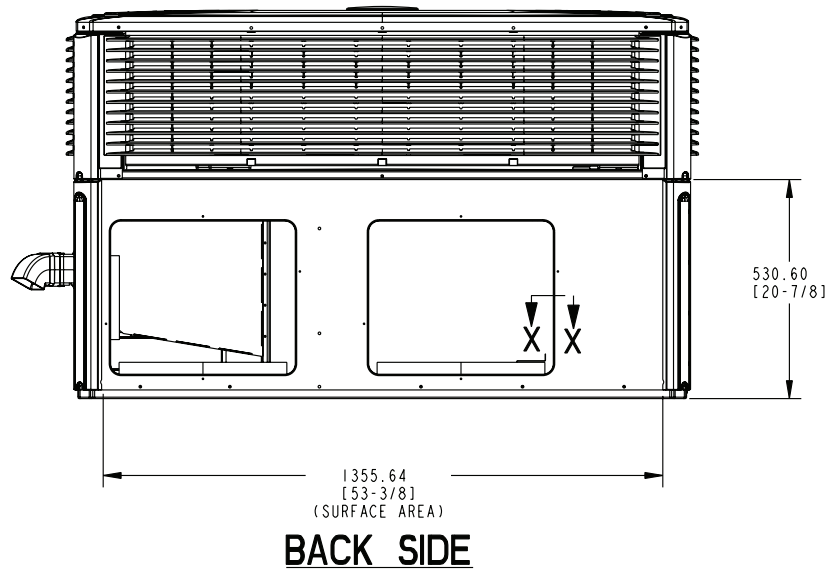
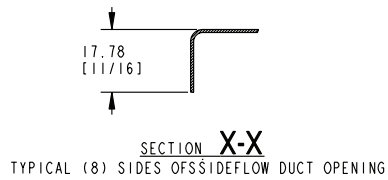
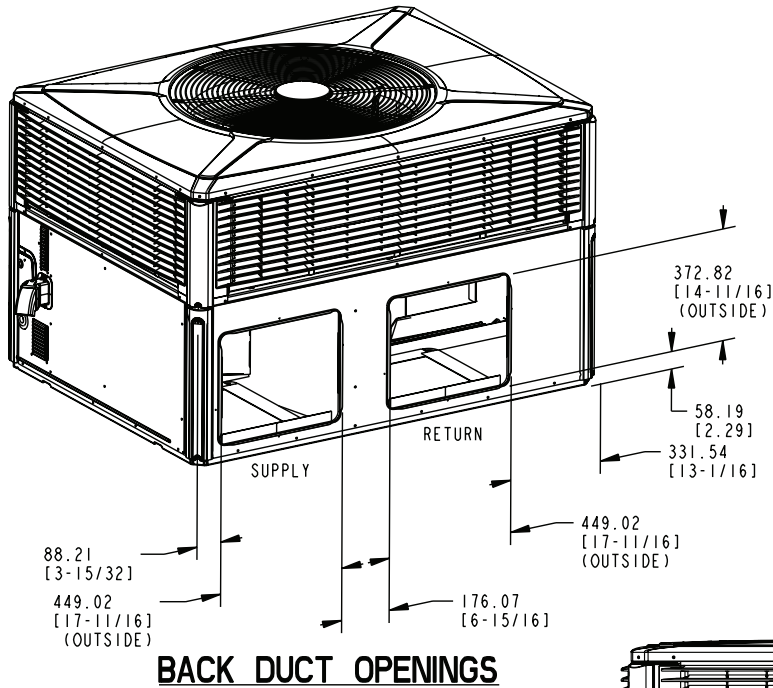

MODEL	HEIGHT MM/IN.	APPROX. CORNER WEIGHT - KG/LBS				SHIPPING WEIGHT KG/LBS	TOTAL UNIT WEIGHT KG/LBS	CENTER OF GRAVITY MM/IN.	
	A	W1	W2	W3	W4			B	C
4YCY4042C (090)	949.33 [37-3/8]	75.3 [166]	50.3 [111]	45.4 [100]	67.6 [149]	296.5 [653]	238.1 [525]	444.5 [17.5]	698.5 [27.5]
4YCY4048C (090)	949.33 [37-3/8]	77.1 [170]	52.2 [115]	47.2 [104]	69.4 [153]	303.4 [669]	245.9 [541]	444.5 [17.5]	698.5 [27.5]
4YCY4048C (115)	949.33 [37-3/8]	77.1 [170]	52.2 [115]	47.2 [104]	69.4 [153]	303.4 [669]	245.9 [541]	444.5 [17.5]	698.5 [27.5]
4YCY4060C (115)	1050.93 [41-3/8]	82.1 [181]	46.3 [102]	43.1 [95]	76.7 [169]	306.9 [676]	248.6 [548]	401.3 [15.8]	711.2 [28.0]
4DCY4042C (090)	949.33 [37-3/8]	77.1 [170]	51.3 [113]	45.4 [100]	67.6 [149]	296.5 [653]	238.4 [525]	442.0 [17.4]	698.5 [27.5]
4DCY4048C (090)	949.33 [37-3/8]	78.9 [174]	53.0 [117]	47.2 [104]	69.4 [153]	306.6 [676]	248.5 [548]	442.0 [17.4]	698.5 [27.5]
4DCY4060C (115)	1050.93 [41-3/8]	83.9 [185]	47.2 [104]	43.1 [95]	76.7 [169]	306.9 [676]	248.8 [548]	398.8 [15.7]	711.2 [28.0]
4YCY6048C (090)	1050.93 [41-3/8]	75.7 [167]	50.8 [112]	45.8 [101]	68.5 [151]	299.2 [659]	240.9 [531]	444.5 [17.5]	698.5 [27.5]
4YCY6048C (115)		81.6 [180]	46.3 [102]	42.2 [93]	73.5 [162]	301.6 [665]	243.6 [537]	419.1 [16.5]	706.1 [27.8]
4YCY6060C (115)	1050.93 [41-3/8]	82.1 [181]	46.3 [102]	43.1 [95]	76.7 [169]	306.9 [676]	248.6 [548]	401.3 [15.8]	711.2 [28.0]
4DCY6048C (090)	1050.93 [41-3/8]	81.6 [180]	46.3 [102]	42.2 [93]	73.5 [162]	301.6 [665]	243.6 [537]	419.1 [16.5]	706.1 [27.8]
4DCY6060C (115)	1050.93 [41-3/8]	83.9 [185]	47.2 [104]	43.1 [95]	75.7 [169]	306.9 [676]	248.8 [548]	398.8 [15.7]	711.2 [28.0]

4YCY4042 through 4YCY4060 (3 of 3)

# Mechanical Specifications

## General

All units shall be factory assembled, piped, internally wired and fully charged with refrigerant. All units shall be designed to operate at outdoor ambient temperatures as high as 115°F. Cooling capacities shall be rated in accordance with A.H.R.I. standards. The unit design is certified to ANSI 221.47/CSA 2.3 specifically for outdoor applications using natural gas or propane. All units shall be designed for outdoor rooftop or ground level installation. Unit casing is constructed of heavy gauge, galvanized steel and painted with a weather-resistant powder paint.

**Shipped for horizontal application, convertible to downflow.**

## Casings

All panels shall be heavy gauge steel, gasketed and insulated. Foil-faced insulation shall be in the heat exchanger section. Foil-faced insulation shall be in the evaporator section. Base pan shall be heavy gauge steel. **WEATHERGUARD™** exterior corrosion resistant screws shall be used for added resistance to rust and corrosion.

## Controls

Refrigeration cycle controls shall include condenser fan, evaporator fan and compressor contactors. Compressors shall be equipped with a combination internal winding thermostat/current overload. Internal high pressure relief shall also be provided.

## Refrigeration System

### Compressors —

The **Climatuff®** compressor features internal over temperature and pressure protector, total dipped hermetic motor. Other features include: centrifugal oil pump, and low vibration and noise.

**Evaporator Coil —** Internally enhanced 3/8-inch OD seamless copper tubing mechanically bonded to aluminum fins, factory pressure and leak tested at 250 to 300 psig. All units have TXV to control refrigeration flow.

### Condenser Coil —

The **Spine Fin™** condenser coil shall be continuously wrapped, corrosion resistant all aluminum with minimum brazed joints. This coil is 3/8 inch OD seamless aluminum tubing glued to a continuous aluminum fin. Coils are lab tested to withstand 2,000 pounds of pressure per square inch. The outdoor coil provides low airflow resistance and efficient heat transfer. The coil is protected on all four sides by louvered panels.

**Indoor Air Fan —** Direct-drive, forward-curved, centrifugal wheel in a Composite **Vortica®** Blower housing. Motor shall have thermal overload protection. Permanently lubricated motor bearings. Motor/blower assembly isolated from unit with rubber mounts.

**Condenser Fan —** Direct-drive, draw through propeller type. Weather-proofed permanent split capacitor fan motor shall have built-in thermal overload and permanently lubricated motor bearings.

**Low Ambient —** Standard refrigerant system operation down to 55°F. Low ambient accessory required for operation to 0°F ambient condition.

**Gas-Fired Heating System —** Models shall provide completely assembled, wired and piped gas fired heating systems within unit. Design certified by UL, specifically for outdoor application. Threaded gas connection on the unit.

**Electronic Ignition System —** Main burner is lit each time thermostat calls for gas heat. Flame sensor proves flame and keeps the main burners on. Should a loss of flame occur, the main valve closes and the spark recurs within 0.8 second. When thermostat is satisfied, main burner is extinguished.

**Forced Combustion Blower —** Insures flame stability under varying wind conditions. Gives higher combustion efficiency and location flexibility.

**Heat Exchanger —** stainless steel tubes. Free floating design.

**Burners —** stainless steel. Multi-port inshot.

## Accessories

### (U.S. Domestic Models)

**Roof Curb —** The roof curb shall be designed to mate with the unit and provide support and complete weather-tight installation when properly installed. Curb shall ship knocked down for field assembly, and include wood nailer strips.

**Modulating Economizer —** This accessory shall be field installed and be composed of the following items: 0-100% fresh air damper, damper drive motor fixed dry bulb enthalpy control, and low voltage polarized plug for electrical connections. Solid state enthalpy or differential enthalpy control is optional. Economizer operations shall be controlled by the preset position of the enthalpy control. A barometric relief damper shall be standard with the economizer and provide a pressure operated damper that shall be gravity closing and prohibit entrance of outside air on equipment "off" cycle.

### Manual Fresh Air Hood

Manual outside air provides a fixed outside air quantity from 0 to 25 percent. Includes hood and birdscreen.

### Low Ambient Control

Control allows cycling of compressor under low ambient cooling conditions. Required for cooling operation to 0°F.

### Propane Gas

**Conversion Kit —** For conversion from natural gas to LP gas.



Trane - by Trane Technologies (NYSE: TT), a global climate innovator - creates comfortable, energy efficient indoor environments for commercial and residential applications. For more information, please visit [trane.com](http://trane.com) or [tranetechnologies.com](http://tranetechnologies.com).



The AHRI Certified mark indicates Trane U.S. Inc. participation in the AHRI Certification program. For verification of individual certified products, go to [ahridirectory.org](http://ahridirectory.org).

Trane has a policy of continuous data improvement and it reserves the right to change design and specifications without notice. We are committed to using environmentally conscious print practices.