



TRANE®

Upflow/Downflow Horizontal Right or Left Gas-Fired Furnace

XT 80

TUD1A040A9H21B, TUD1A040G9H21A

TUD1B060A9H31B, TUD1B060G9H31A

TUD1B080A9H31B, TUD1B080G9H31A

TUD1C080A9H41B, TUD1C080G9H41A

TUD1B100A9H31B, TUD1B100G9H31A

TUD1C100A9H51B, TUD1C100G9H51A

TUD1D120A9H51B, TUD1D120G9H51A

TUD1D140A9H51B, TUD1D140G9H51A

TDD1B060A9H31B, TDD1B080A9H31B

TDD1C100A9H51B, TDD1D120A9H51B

Single Stage, High Efficiency Motor

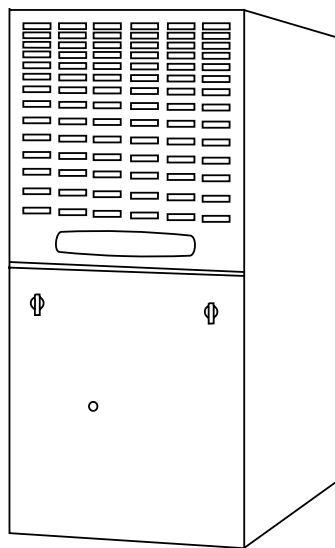

Upflow/Horizontal*

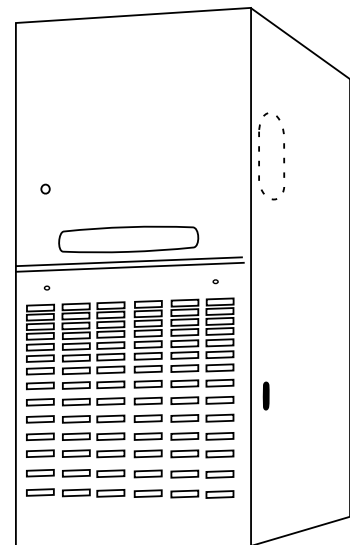

Downflow/Horizontal*

*Horizontal Conversion for these furnaces may be left or right side rotation.



General Features

Natural Gas Models

Central heating furnace designs are certified by the American Gas Association for both natural and L.P. gas. Limit setting and rating data were established and approved under standard rating conditions using American National Standards Institute standards.

Safe Operation

The Integrated System Control has solid state devices, which continuously monitor for presence of flame, when the system is in the heating mode of operation. Dual solenoid combination gas valve and regulator provide extra safety.

Quick Heating

Durable, cycle tested, heavy gauge **aluminized steel heat exchanger** quickly transfers heat to provide warm conditioned air to the structure.

Burners

Multi-port In-shot burners will give years of quiet and efficient service. All models can be converted to **L.P. gas**.

Integrated System Control

Exclusively designed operational program provides total control of furnace limit sensors, blowers, gas valve, flame control and includes self-diagnostics for ease of service. Also contains connection points for E.A.C./humidifier.

Air Delivery

The multispeed, high efficiency, direct drive blower motor, with sufficient airflow range for most heating and cooling requirements, will switch from heating to cooling speeds on demand from room thermostat. The blower door safety switch will prevent or terminate furnace operation when the blower door is removed.

Styling

Heavy gauge steel and “wrap-around” cabinet construction is used in the cabinet with baked-on enamel finish for strength and beauty. The heat exchanger section of the cabinet is completely lined with foil faced fiberglass insulation. This results in quiet and efficient operation due to the excellent acoustical and insulating qualities of fiberglass.

Features And General Operation

The XT80 High Efficiency Gas Furnaces employ a Hot Surface Ignition system, which eliminates the waste of a constant burning pilot. The integrated system control lights the main burners upon a demand for heat from the room thermostat. Complete front service access.

- a. Low energy power venter.
- b. Vent proving differential switch.



Contents

General Features	2
Features and Benefits	4
Standard Equipment	4
Optional Equipment	5
General Data	6
TUD1A040A9H21B, TUD1A040G9H21A	6
TUD1B060A9H31B, TUD1B060G9H31A	6
TUD1B080A9H31B, TUD1B080G9H31A	6
TUD1C080A9H41B, TUD1C080G9H41A	6
TUD1B100A9H31B, TUD1B100G9H31A	7
TUD1C100A9H51B, TUD1C100G9H51A	7
TUD1D120A9H51B, TUD1D120G9H51A	7
TUD1D140A9H51B, TUD1D140G9H51A	7
TDD1B060A9H31B	8
TDD1B080A9H31B	8
TDD1C100A9H51B	8
TDD1D120A9H51B	8
Performance Data	9
Electrical Data	12
Field Wiring	16
Twinning Field Wiring	17
Dimensions	18



Features and Benefits

XT80 Upflow/Downflow Horizontal Right or Left Standard Equipment

- Convertible to horizontal with left or right airflow
- Power supply 115/1/60
- Silicon Nitride Hot surface igniter with adaptive heat up
- Integrated solid state control with self-diagnostics
- Single wire twinning
- Attractive color accents
- Hinged blower door
- Perfect Fit door latches
- Insulated blower door
- Gasketed blower door
- Internal filter rack
- Standard filter sizes
- Cleanable high velocity filters
- Heavy gauge aluminized steel heat exchanger
- Blower door safety switch
- Constant torque ECM blower motor
- Multi-port In-shot burners
- Complete front service access
- Alternate bottom/left/right return air
- Slide out blower assembly
- High efficiency direct drive 4 speed motor
- Adjustable fan off times
- Common vent capability
- Heavy gauge reinforced wrap-around steel cabinet
- Optional L.P. conversion kit
- Left/right gas connection
- Accessory hook-up capability
- Selectable cooling fan off eliminates need for BAY24X045 time delay relay
- 24 volt fuse
- Manual reset flame roll-out switches



Features and Benefits

Optional Equipment

OPTIONAL EQUIPMENT FOR CONDENSING UNITS (Check mark [✓] indicates accessories included).

For Comfort Controls, See price book pages	[]
CleanEffects™ Whole House Air Cleaner (14-1/2" Wide, Upflow / Side Return Furnace)	TFD145ALFR000A []
CleanEffects™ Whole House Air Cleaner (17-1/2" Wide, Upflow / Side Return Furnace)	TFD175ALFR000A []
CleanEffects™ Whole House Air Cleaner (21" Wide, Upflow / Side Return Furnace)	TFD210ALFR000A []
CleanEffects™ Whole House Air Cleaner (24-1/2" Wide, Upflow / Side Return Furnace)	TFD245ALFR000A []
CleanEffects™ Whole House Air Cleaner (14-1/2" Wide, Downflow Furnace)	TFD14DALFR000A []
CleanEffects™ Whole House Air Cleaner (17-1/2" Wide, Downflow Furnace)	TFD17DALFR000A []
CleanEffects™ Whole House Air Cleaner (21" Wide, Downflow Furnace)	TFD21DALFR000A []
CleanEffects™ Whole House Air Cleaner (24-1/2" Wide, Downflow Furnace)	TFD24DALFR000A []
Electronic Air Filter, "Perfect Fit" Super Efficiency (14-1/2" Wide Gas Furnace)	TFE145A9FR0 []
Electronic Air Filter, "Perfect Fit" Super Efficiency (17-1/2" Wide Gas Furnace)	TFE175A9FR0 []
Electronic Air Filter, "Perfect Fit" Super Efficiency (21" Wide Gas Furnace)	TFE210A9FR0 []
Electronic Air Filter, "Perfect Fit" Super Efficiency (24-1/2" Wide Gas Furnace)	TFE245A9FR0 []
Air Filter, "Perfect Fit" High Efficiency (14-1/2" Wide Gas Furnace)	TFM145A9FR0 []
Air Filter, "Perfect Fit" High Efficiency (17-1/2" Wide Gas Furnace)	TFM175A9FR0 []
Air Filter, "Perfect Fit" High Efficiency (21" Wide Gas Furnace)	TFM210A9FR0 []
Air Filter, "Perfect Fit" High Efficiency (24-1/2" Wide Gas Furnace)	TFM245A9FR0 []
Air Filter, "Perfect Fit" Standard Efficiency (14-1/2" Wide Gas Furnace)	TFP145A9FR0 []
Air Filter, "Perfect Fit" Standard Efficiency (17-1/2" Wide Gas Furnace)	TFP175A9FR0 []
Air Filter, "Perfect Fit" Standard Efficiency (21" Wide Gas Furnace)	TFP210A9FR0 []
Air Filter, "Perfect Fit" Standard Efficiency (24-1/2" Wide Gas Furnace)	TFP245A9FR0 []
Coil Enclosure (14-1/2" Wide Cabinets)	BAYCLE14A1422A []
Coil Enclosure (17-1/2" Wide Cabinets)	BAYCLE17A1722A []
Coil Enclosure (21" Wide Cabinets)	BAYCLE21A2130A []
Coil Enclosure (24-1/2" Wide Cabinets)	BAYCLE24A2430A []
High Altitude Switch	BAYHALT248 []
Downflow Subbase	BAYBASE205 []
Propane Conversion Kit	BAYLPKT210B []
Propane Conversion Kit (With Stainless Steel burners)	BAYLPSS210B []
Masonry Chimney Vent Kit (Upflow models only)	BAYVENT800B []
Filter Access Door Kit (Downflow models)	BAYFLTR206 []



General Data

TUD1-H Product Specifications ^①

MODEL	TUD1A040A9H21B TUD1A040G9H21A	TUD1B060A9H31B TUD1B060G9H31A	TUD1B080A9H31B TUD1B080G9H31A	TUD1C080A9H41B TUD1C080G9H41A
RATINGS ^②				
Input BTUH	40000	60000	80000	80000
Capacity BTUH (ICS) ^③	32000	47000	63000	64000
AFUE	80.0	80.0	80.0	80.0
Temp. Rise (Min.-Max.) °F.	30 - 60	30 - 60	30 - 60	30 - 60
BLOWER DRIVE	DIRECT	DIRECT	DIRECT	DIRECT
Dia.-Width (In.)	10 x 6	10 x 7	10 x 8	11 x 10
No. Used	1	1	1	1
Speeds (No.)	4	4	4	4
CFM vs. in. w.g.	SEE FAN PERF. TABLE	SEE FAN PERF. TABLE	SEE FAN PERF. TABLE	SEE FAN PERF. TABLE
Motor HP ^⑤	1/2	1/2	1/2	3/4
R.P.M.	1080	1075	1075	1100
Volts/Ph/Hz	115/1/60	115/1/60	115/1/60	115/1/60
FLA	6.8	6.8	6.8	8.4
COMBUSTION FAN — TYPE	CENTRIFUGAL	CENTRIFUGAL	CENTRIFUGAL	CENTRIFUGAL
Drive - No. Speeds	DIRECT - 1	DIRECT - 1	DIRECT - 1	DIRECT - 1
Motor HP - RPM	1/50 - 3180	1/50 - 3180	1/50 - 3180	1/50 - 3180
Volts/Ph/Hz	115/1/60	115/1/60	115/1/60	115/1/60
FL Amps	1.09	1.09	1.09	1.09
FILTER — Furnished?	Yes	Yes	Yes	Yes
Type Recommended	High Velocity	High Velocity	High Velocity	High Velocity
Filter (No.-Size-Thk.)	1 - 14 X 25 - 1 IN.	1 - 17 X 25 - 1 IN.	1 - 17 X 25 - 1 IN.	1 - 20 X 25 - 1 IN.
VENT — Size (In.)	4 ROUND	4 ROUND	4 ROUND	4 ROUND
HEAT EXCHANGER				
Type -Fired	ALUMINIZED STEEL TYPE 1	ALUMINIZED STEEL TYPE 1	ALUMINIZED STEEL TYPE 1	ALUMINIZED STEEL TYPE 1
-Unfired				
Gauge (Fired)	20	20	20	20
ORIFICES — Main				
Nat. Gas. Qty. — Drill Size	2 - 45	3 - 45	4 - 45	4 - 45
L.P. Gas Qty. — Drill Size	2 - 56	3 - 56	4 - 56	4 - 56
GAS VALVE	REDUNDANT - SINGLE STAGE	REDUNDANT - SINGLE STAGE	REDUNDANT - SINGLE STAGE	REDUNDANT - SINGLE STAGE
DIRECT IGNITION DEVICE				
Type	HOT SURFACE	HOT SURFACE	HOT SURFACE	HOT SURFACE
BURNERS — Type	IN-SHOT	IN-SHOT	IN-SHOT	IN-SHOT
Number	2	3	4	4
POWER CONN. — V/Ph/Hz ^④	115/1/60	115/1/60	115/1/60	115/1/60
Ampacity (In Amps)	10.3	10.3	10.3	12.3
Max. Overcurrent Protection (Amps)	15	15	15	15
PIPE CONN. SIZE (IN.)	1/2	1/2	1/2	1/2
DUCT CONN.	SEE OUTLINE DRAWING	SEE OUTLINE DRAWING	SEE OUTLINE DRAWING	SEE OUTLINE DRAWING
DIMENSIONS	H X W X D	H X W X D	H X W X D	H X W X D
Crated (In.)	41-3/4 X 16-1/2 X 30-1/2	41-3/4 X 19-1/2 X 30-1/2	41-3/4 X 19-1/2 X 30-1/2	41-3/4 X 23 X 30-1/2
Uncrated	SEE OUTLINE DRAWING	SEE OUTLINE DRAWING	SEE OUTLINE DRAWING	SEE OUTLINE DRAWING
WEIGHT				
Shipping (Lbs.)/Net (Lbs.)	119/110	136/126	142/132	162/151

① Central Furnace heating designs are certified to ANSI Z21.47 / CSA 2.3.

② For U.S. applications, above input ratings (BTUH) are up to 2,000 feet, derate 4% per 1,000 feet for elevations above 2,000 feet above sea level.

For Canadian applications, above input ratings (BTUH) are up to 4,500 feet, derate 4% per 1,000 feet for elevations above 4,500 feet above sea level.

③ Based on U.S. government standard tests.

④ The above wiring specifications are in accordance with National Electrical Code; however, installations must comply with local codes.

⑤ Constant torque ECM blower motor.



General Data

TUD1-H Product Specifications ^①

MODEL	TUD1B100A9H31B	TUD1C100A9H51B	TUD1D120A9H51B	TUD1D140A9H51B
	TUD1B100G9H31A	TUD1C100G9H51A	TUD1D120G9H51A	TUD1D140G9H51A
RATINGS^②				
Input BTUH	100000	100000	120000	140000
Capacity BTUH (ICS) ^③	80000	79000	96000	111000
AFUE	80.0	80.0	80.0	80.0
Temp. Rise (Min.-Max.) °F.	40 - 70	30 - 60	30 - 60	40 - 70
BLOWER DRIVE				
Drive	DIRECT	DIRECT	DIRECT	DIRECT
Dia.-Width (In.)	10 x 8	11 x 10	11 x 10	11 x 10
No. Used	1	1	1	1
Speeds (No.)	4	4	4	4
CFM vs. in. w.g.	SEE FAN PERF. TABLE	SEE FAN PERF. TABLE	SEE FAN PERF. TABLE	SEE FAN PERF. TABLE
Motor HP ^⑤	3/4	1	1	1
R.P.M.	1075	1075	1075	1075
Volts/Ph/Hz	115/1/60	115/1/60	115/1/60	115/1/60
FLA	8.4	10.9	10.9	10.9
COMBUSTION FAN — TYPE				
Drive - No. Speeds	CENTRIFUGAL DIRECT - 1	CENTRIFUGAL DIRECT - 1	CENTRIFUGAL DIRECT - 1	CENTRIFUGAL DIRECT - 1
Motor HP - RPM	1/50 - 3180	1/50 - 3180	1/50 - 3180	1/50 - 3180
Volts/Ph/Hz	115/1/60	115/1/60	115/1/60	115/1/60
FL Amps	1.09	1.09	1.09	1.09
FILTER — Furnished?				
Type Recommended	Yes High Velocity	Yes High Velocity	Yes High Velocity	Yes High Velocity
Filter (No.-Size-Thk.)	1 - 17 X 25 - 1 IN.	1 - 20 X 25 - 1 IN.	1 - 24 X 25 - 1 IN.	1 - 24 X 25 - 1 IN.
VENT — Size (In.)				
	4 ROUND	4 ROUND	4 ROUND	4 ROUND
HEAT EXCHANGER				
Type -Fired	ALUMINIZED STEEL TYPE 1	ALUMINIZED STEEL TYPE 1	ALUMINIZED STEEL TYPE 1	ALUMINIZED STEEL TYPE 1
-Unfired				
Gauge (Fired)	20	20	20	20
ORIFICES — Main				
Nat. Gas. Qty. — Drill Size	5 - 45	5 - 45	6 - 45	7 - 45
L.P. Gas Qty. — Drill Size	5 - 56	5 - 56	6 - 56	7 - 56
GAS VALVE				
	REDUNDANT - SINGLE STAGE	REDUNDANT - SINGLE STAGE	REDUNDANT - SINGLE STAGE	REDUNDANT - SINGLE STAGE
DIRECT IGNITION DEVICE				
Type	HOT SURFACE	HOT SURFACE	HOT SURFACE	HOT SURFACE
BURNERS — Type				
Number	IN-SHOT 5	IN-SHOT 5	IN-SHOT 6	IN-SHOT 7
POWER CONN. — V/Ph/Hz^④				
Ampacity (In Amps)	115/1/60 12.3	115/1/60 15.4	115/1/60 15.4	115/1/60 15.4
Max. Overcurrent Protection (Amps)	15	20	20	20
PIPE CONN. SIZE (IN.)				
	1/2	1/2	1/2	1/2
DUCT CONN.				
	SEE OUTLINE DRAWING	SEE OUTLINE DRAWING	SEE OUTLINE DRAWING	SEE OUTLINE DRAWING
DIMENSIONS				
Crated (In.)	H X W X D 41-3/4 X 19-1/2 X 30-1/2	H X W X D 41-3/4 X 23 X 30-1/2	H X W X D 41-3/4 X 26-1/2 X 30-1/2	H X W X D 41-3/4 X 26-1/2 X 30-1/2
Uncrated	SEE OUTLINE DRAWING	SEE OUTLINE DRAWING	SEE OUTLINE DRAWING	SEE OUTLINE DRAWING
WEIGHT				
Shipping (Lbs.)/Net (Lbs.)	153/143	162/151	186/174	193/181

① Central Furnace heating designs are certified to ANSI Z21.47 / CSA 2.3.

② For U.S. applications, above input ratings (BTUH) are up to 2,000 feet, derate 4% per 1,000 feet for elevations above 2,000 feet above sea level.

For Canadian applications, above input ratings (BTUH) are up to 4,500 feet, derate 4% per 1,000 feet for elevations above 4,500 feet above sea level.

③ Based on U.S. government standard tests.

④ The above wiring specifications are in accordance with National Electrical Code; however, installations must comply with local codes.

⑤ Constant torque ECM blower motor.



General Data

TDD1-H Product Specifications ^①

MODEL	TDD1B060A9H31B	TDD1B080A9H31B	TDD1C100A9H51B	TDD1D120A9H51B
RATINGS ^②				
Input BTUH	60000	80000	100000	120000
Capacity BTUH (ICS) ^③	48000	64000	81000	96000
AFUE	80.0	80.0	80.0	80.0
Temp. Rise (Min.-Max.) °F.	25 - 55	35 - 65	30 - 60	35 - 65
BLOWER DRIVE				
	DIRECT	DIRECT	DIRECT	DIRECT
Dia.-Width (In.)	10 x 7	10 x 8	11 x 10	11 x 10
No. Used	1	1	1	1
Speeds (No.)	4	4	4	4
CFM vs. in. w.g.	SEE FAN PERF. TABLE	SEE FAN PERF. TABLE	SEE FAN PERF. TABLE	SEE FAN PERF. TABLE
Motor HP ^⑤	1/2	1/2	1	1
R.P.M.	1075	1075	1075	1075
Volts/Ph/Hz	115/1/60	115/1/60	115/1/60	115/1/60
FLA	6.8	6.8	10.9	10.9
COMBUSTION FAN — TYPE				
	CENTRIFUGAL	CENTRIFUGAL	CENTRIFUGAL	CENTRIFUGAL
Drive - No. Speeds	DIRECT - 1	DIRECT - 1	DIRECT - 1	DIRECT - 1
Motor HP - RPM	1/50 - 3180	1/50 - 3180	1/50 - 3180	1/50 - 3180
Volts/Ph/Hz	115/1/60	115/1/60	115/1/60	115/1/60
FL Amps	1.09	1.09	1.09	1.09
FILTER — Furnished?				
	Yes	Yes	Yes	Yes
Type Recommended	High Velocity	High Velocity	High Velocity	High Velocity
Filter (No.-Size-Thk.)	2 - 14 X 20 - 1 IN	2 - 14 X 20 - 1 IN	2 - 16 X 20 - 1 IN	2 - 16 X 20 - 1 IN
VENT — Size (In.)				
	4 ROUND	4 ROUND	4 ROUND	4 ROUND
HEAT EXCHANGER				
Type -Fired	ALUMINIZED STEEL TYPE 1	ALUMINIZED STEEL TYPE 1	ALUMINIZED STEEL TYPE 1	ALUMINIZED STEEL TYPE 1
-Unfired				
Gauge (Fired)	20	20	20	20
ORIFICES — Main				
Nat. Gas Qty. — Drill Size	3 - 45	4 - 45	5 - 45	6 - 45
L.P. Gas Qty. — Drill Size	3 - 56	4 - 56	5 - 56	6 - 56
GAS VALVE				
	REDUNDANT - SINGLE STAGE	REDUNDANT - SINGLE STAGE	REDUNDANT - SINGLE STAGE	REDUNDANT - SINGLE STAGE
DIRECT IGNITION DEVICE				
Type	HOT SURFACE	HOT SURFACE	HOT SURFACE	HOT SURFACE
BURNERS — Type				
	IN-SHOT	IN-SHOT	IN-SHOT	IN-SHOT
Number	3	4	5	6
POWER CONN. — V/Ph/Hz ^④				
	115/1/60	115/1/60	115/1/60	115/1/60
Ampacity (In Amps)	10.3	10.3	15.4	15.4
Max. Overcurrent Protection (Amps)	15	15	20	20
PIPE CONN. SIZE (IN.)				
	1/2	1/2	1/2	1/2
DUCT CONN.				
	SEE OUTLINE DRAWING	SEE OUTLINE DRAWING	SEE OUTLINE DRAWING	SEE OUTLINE DRAWING
DIMENSIONS				
	H X W X D	H X W X D	H X W X D	H X W X D
Crated (In.)	41 X 19-1/2 X 29-1/2	41-3/4 X 18-1/2 X 29-1/2	41-3/4 X 22 X 29-1/2	41 X 25-1/2 X 29-1/2
Uncrated	SEE OUTLINE DRAWING	SEE OUTLINE DRAWING	SEE OUTLINE DRAWING	SEE OUTLINE DRAWING
WEIGHT				
Shipping (Lbs.)/Net (Lbs.)	136 / 126	146 / 135	167/155	189 / 176

① Central Furnace heating designs are certified to ANSI Z21.47 / CSA 2.3.

② For U.S. applications, above input ratings (BTUH) are up to 2,000 feet, derate 4% per 1,000 feet for elevations above 2,000 feet above sea level.

For Canadian applications, above input ratings (BTUH) are up to 4,500 feet, derate 4% per 1,000 feet for elevations above 4,500 feet above sea level.

③ Based on U.S. government standard tests.

④ The above wiring specifications are in accordance with National Electrical Code; however, installations must comply with local codes.

⑤ Constant torque ECM blower motor.



Performance Data

TUD1-H Airflow

FURNACE AIRFLOW (CFM) VS. STATIC PRESSURE (ins.w.g.)										
MODEL	SPEED TAP	0.1	0.2	0.3	0.4	0.5	0.6	0.7	0.8	0.9
*UD1A040A9H21B *UD1A040G9H21A	4 - HIGH - Black	1121	1094	1067	1039	1011	983	955	929	902
	3 - MED-HIGH - Blue	926	896	866	837	808	783	757	723	689
	2 - MED-LOW - Yellow	761	720	678	648	617	583	548	514	479
	1 - LOW - Red	750	644	538	499	459	415	371	337	303
*UD1B060A9H31B *UD1B060G9H31A	4 - HIGH - Black	1360	1329	1298	1268	1238	1208	1178	1147	1116
	3 - MED-HIGH - Blue	1188	1152	1116	1089	1062	1031	1000	962	924
	2 - MED-LOW - Yellow	1040	1003	966	931	896	861	826	787	747
	1 - LOW - Red	942	873	803	771	739	699	659	619	579
*UD1B080A9H31B *UD1B080G9H31A	4 - HIGH - Black	1440	1406	1372	1345	1318	1287	1255	1219	1183
	3 - MED-HIGH - Blue	1249	1219	1189	1158	1127	1091	1055	1019	982
	2 - MED-LOW - Yellow	1179	1143	1106	1078	1050	1010	970	929	887
	1 - LOW - Red	1048	989	929	888	847	802	757	708	658
*UD1C080A9H41B *UD1C080G9H41A	4 - HIGH - Black	1755	1717	1678	1639	1600	1561	1522	1481	1439
	3 - MED-HIGH - Blue	1519	1478	1436	1394	1351	1309	1267	1225	1182
	2 - MED-LOW - Yellow	1369	1265	1161	1115	1068	1023	978	925	871
	1 - LOW - Red	1300	1161	1021	965	909	860	810	754	697
*UD1B100A9H31B *UD1B100G9H31A	4 - HIGH - Black	1380	1355	1330	1305	1280	1248	1216	1191	1165
	3 - MED-HIGH - Blue	1283	1258	1232	1204	1176	1144	1112	1084	1056
	2 - MED-LOW - Yellow	1176	1142	1108	1081	1054	1019	983	947	911
	1 - LOW - Red	1029	996	962	928	894	855	816	756	696
*UD1C100A9H51B *UD1C100G9H51A	4 - HIGH - Black	2195	2154	2113	2076	2038	1992	1945	1876	1807
	3 - MED-HIGH - Blue	1998	1959	1919	1883	1847	1814	1781	1744	1706
	2 - MED-LOW - Yellow	1813	1778	1742	1703	1664	1630	1595	1560	1525
	1 - LOW - Red	1630	1590	1550	1511	1471	1434	1396	1361	1325
*UD1D120A9H51B *UD1D120G9H51A	4 - HIGH - Black	2119	2091	2062	2029	1996	1959	1921	1887	1852
	3 - MED-HIGH - Blue	1963	1929	1895	1857	1818	1785	1751	1716	1681
	2 - MED-LOW - Yellow	1751	1712	1673	1638	1602	1566	1529	1490	1451
	1 - LOW - Red	1579	1541	1502	1459	1416	1378	1340	1293	1246
*UD1D140A9H51B *UD1D140G9H51A	4 - HIGH - Black	2130	2096	2062	2023	1984	1952	1919	1884	1849
	3 - MED-HIGH - Blue	1935	1896	1857	1824	1790	1750	1709	1673	1636
	2 - MED-LOW - Yellow	1752	1711	1669	1632	1594	1551	1507	1472	1436
	1 - LOW - Red	1576	1533	1490	1452	1413	1375	1336	1295	1254

* May be "A" or "T"

- ① Central Furnace heating designs are certified to ANSI Z21.47 / CSA 2.3.
- ② For U.S. applications, above input ratings (BTUH) are up to 2,000 feet, derate 4% per 1,000 feet for elevations above 2,000 feet above sea level.
For Canadian applications, above input ratings (BTUH) are up to 4,500 feet, derate 4% per 1,000 feet for elevations above 4,500 feet above sea level.
- ③ Based on U.S. government standard tests.
- ④ The above wiring specifications are in accordance with National Electrical Code; however, installations must comply with local codes.



Performance Data

TUD1-H CFM

CFM VS. TEMPERATURE RISE																		
MODEL	CFM (CUBIC FEET PER MINUTE)																	
	400	500	600	700	800	900	1000	1100	1200	1300	1400	1500	1600	1700	1800	1900	2000	2100
*UD1A040A9H21B *UD1A040G9H21A		59	49	42	37	33	30											
*UD1B060A9H31B *UD1B060G9H31A				63	56	49	44	40	37	34	32	30						
*UD1B080A9H31B *UD1B080G9H31A							59	54	49	46	42	40	37	35	33	31		
*UD1C080A9H41B *UD1C080G9H41A							59	54	49	46	42	40	37	35	33	31		
*UD1B100A9H31B *UD1B100G9H31A							74	67	62	57	53	49	46	44	41			
*UD1C100A9H51B *UD1C100G9H51A									62	57	53	49	46	44	41	39	37	35
*UD1D120A9H51B *UD1D120G9H51A												59	56	52	49	47	44	42
*UD1D140A9H51B *UD1D140G9H51A												69	65	61	58	55	52	49

* May be "A" or "T"

TDD1-H CFM

CFM VS. TEMPERATURE RISE																		
MODEL	CFM (CUBIC FEET PER MINUTE)																	
	400	500	600	700	800	900	1000	1100	1200	1300	1400	1500	1600	1700	1800	1900	2000	2100
*DD1B060A9H31B					56	49	44	40	37	34	32	30	28	26				
*DD1B080A9H31B						66	59	54	49	46	42	40	37	35				
*DD1C100A9H51B									62	57	53	49	46	44	41	39	37	35
*DD1D120A9H51B										68	63	59	56	52	49	47	44	42

* May be "A" or "T"



Performance Data

TDD1-H Airflow

FURNACE AIRFLOW (CFM) VS. STATIC PRESSURE (ins.w.g.)										
MODEL	SPEED TAP	0.1	0.2	0.3	0.4	0.5	0.6	0.7	0.8	0.9
*DD1B060A9H31B	4 - HIGH - Black	1449	1415	1381	1345	1309	1265	1220	1143	1066
	3 - MED-HIGH - Blue	1303	1270	1236	1202	1167	1133	1099	1054	1009
	2 - MED-LOW - Yellow	1182	1150	1117	1080	1042	1005	968	933	897
	1 - LOW - Red	1012	974	935	904	872	835	798	760	721
*DD1B080A9H31B	4 - HIGH - Black	1450	1417	1393	1349	1314	1272	1229	1147	1064
	3 - MED-HIGH - Blue	1302	1269	1235	1200	1164	1127	1089	1041	992
	2 - MED-LOW - Yellow	1190	1153	1115	1079	1042	1009	976	934	891
	1 - LOW - Red	1033	992	951	912	873	832	791	729	666
*DD1C100A9H51B	4 - HIGH - Black	2170	2126	2082	2045	2007	1964	1920	1884	1848
	3 - MED-HIGH - Blue	1971	1932	1893	1855	1816	1771	1726	1688	1649
	2 - MED-LOW - Yellow	1766	1720	1674	1633	1591	1547	1502	1456	1409
	1 - LOW - Red	1579	1537	1495	1447	1399	1352	1304	1250	1196
*DD1D120A9H51B	4 - HIGH - Black	2171	2128	2085	2048	2010	1968	1925	1893	1861
	3 - MED-HIGH - Blue	1976	1934	1891	1856	1820	1781	1741	1704	1666
	2 - MED-LOW - Yellow	1770	1730	1690	1652	1614	1575	1535	1493	1450
	1 - LOW - Red	1575	1531	1487	1446	1404	1363	1321	1277	1233
* May be "A" or "T"										



Electrical Data

TUD1-H Wiring Diagram For Gas Furnaces

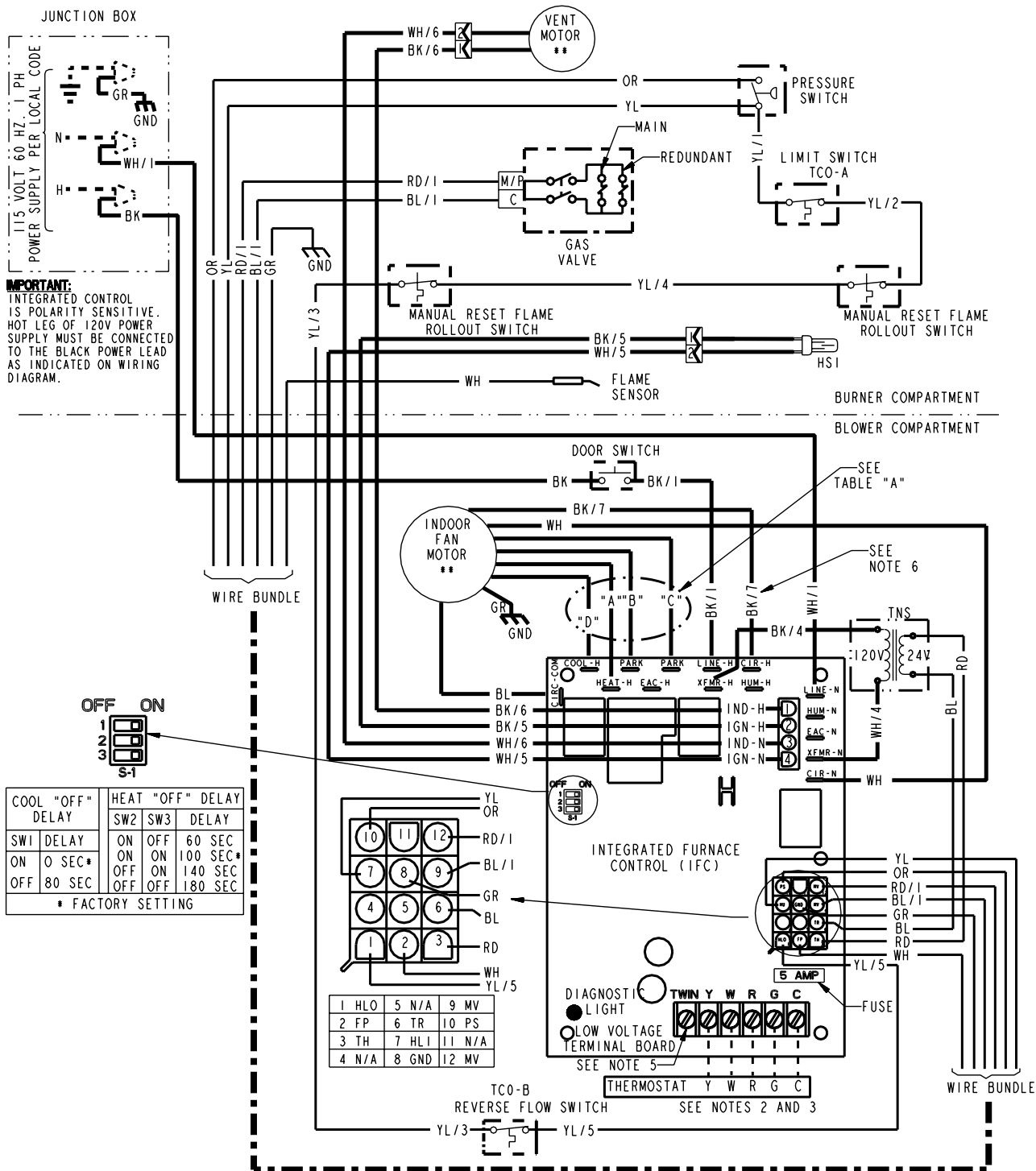

From Dwg. D344956P01

Electrical Data

TUD1-H Schematic Diagram For Gas Furnaces

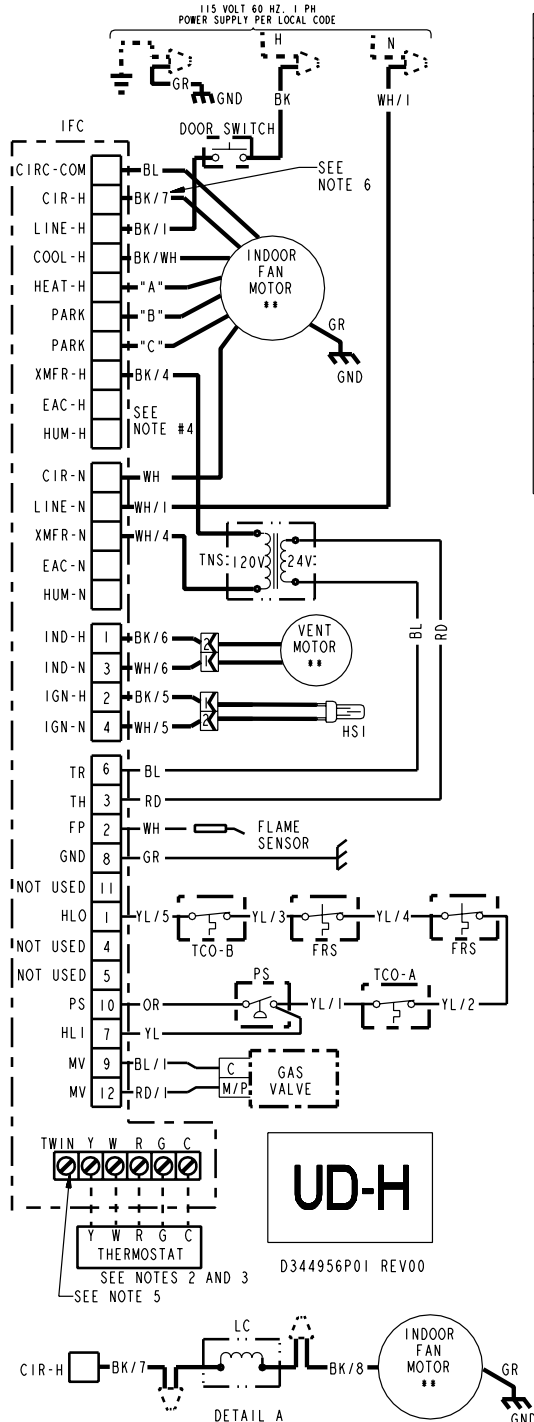

TABLE "A"				
SPEED TAPS FOR I.D. FAN MOTOR				
MODEL	HEAT "A"	PARK "B"	PARK "C"	COOL "D"
*UDI A04A9H21B**	RD/WH	BK/WH	YL/WH	BL/WH
*UDI B06A9H31B**	RD/WH	BL/WH	YL/WH	BK/WH
*UDI B08A9H31B**	YL/WH	BL/WH	RD/WH	BK/WH
*UDIC08A9H41B**	YL/WH	BL/WH	RD/WH	BK/WH
*UDI B10A9H31B**	BL/WH	YL/WH	RD/WH	BK/WH
*UDIC10A9H51B**	RD/WH	BL/WH	YL/WH	BK/WH
*UDI D12A9H51B**	BL/WH	YL/WH	RD/WH	BK/WH
*UDI D14A9H51B**	BL/WH	YL/WH	RD/WH	BK/WH
*UDI A04G9H21A**	RD/WH	BK/WH	YL/WH	BL/WH
*UDI B06G9H31A**	RD/WH	BL/WH	YL/WH	BK/WH
*UDI B08G9H31A**	YL/WH	BL/WH	RD/WH	BK/WH
*UDIC08G9H41A**	YL/WH	BL/WH	RD/WH	BK/WH
*UDI B10G9H31A**	BL/WH	YL/WH	RD/WH	BK/WH
*UDIC10G9H51A**	RD/WH	BL/WH	YL/WH	BK/WH
*UDI D12G9H51A**	BL/WH	YL/WH	RD/WH	BK/WH
*UDI D14G9H51A**	BL/WH	YL/WH	RD/WH	BK/WH

* PREFIX MAY BE "A" OR "T"
 ** SUFFIX MAY BE "A" THROUGH "Z"
 RD/WH = LOW=1 BL/WH = MED. HIGH=3
 YL/WH = MED. LOW=2 BK/WH = HIGH=4

WARNING

HAZARDOUS VOLTAGE:
DISCONNECT ALL ELECTRICAL POWER INCLUDING REMOTE DISCONNECTS BEFORE SERVICING.
FAILURE TO DISCONNECT POWER BEFORE SERVICING CAN CAUSE SEVERE PERSONAL INJURY OR DEATH.

CAUTION

USE COPPER CONDUCTORS ONLY!
UNIT TERMINALS ARE NOT DESIGNED TO ACCEPT OTHER TYPES OF CONDUCTORS.
FAILURE TO DO SO MAY CAUSE DAMAGE TO THE EQUIPMENT.

INTEGRATED FURNACE CONTROL
REPLACE WITH PART CNT04711 OR EQUIVALENT
INPUT: 25 VAC, 60 HZ.
XFMR SEC. CURRENT: 450 MA.
MV OUTPUT: 1.5 A @ 24 VAC
IND OUTPUT: 2.2 FLA, 3.5 LRA @ 120 VAC
CIRC. BLOWER OUTPUT: 14.5 FLA, 14.5 LRA @ 120 VAC
HUMIDIFIER & AIR CLEANER
MAX. LOAD: 1.0 A @ 120 VAC
IGNITER OUTPUT: 2.0 A @ 120 VAC

DIAGNOSTIC CODES

FLASHING SLOW: NORMAL - NO CALL FOR HEAT
FLASHING FAST: NORMAL - CALL FOR HEAT
CONTINUOUS ON: REPLACE IFC
CONTINUOUS OFF: CHECK POWER
2 FLASHES: EXTERNAL LOCKOUT (RETRIES OR RECYCLES EXCEEDED)
3 FLASHES: PRESSURE SWITCH ERROR
4 FLASHES: OPEN LIMIT DEVICE
5 FLASHES: FLAME SENSED WHEN NO FLAME SHOULD BE PRESENT
6 FLASHES: 115 VAC POWER REVERSED POLARITY OR POOR GROUNDING
7 FLASHES: GAS VALVE CIRCUIT ERROR
8 FLASHES: LOW FLAME SENSE SIGNAL
9 FLASHES: CHECK IGNITER

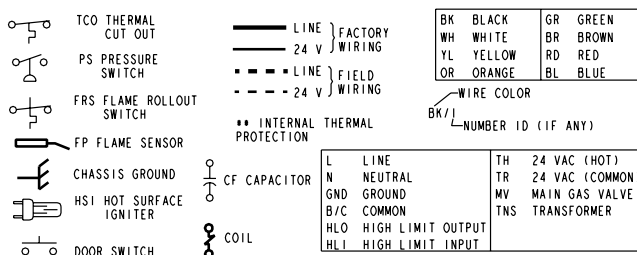

- NOTES:**
- IF ANY OF THE ORIGINAL WIRING AS SUPPLIED WITH THIS FURNACE MUST BE REPLACED, IT MUST BE WITH WIRE HAVING A TEMPERATURE RATING OF AT LEAST 105 C.
 - THERMOSTAT HEAT ANTICIPATOR SETTING: .38 AMPS
 - FOR PROPER OPERATION OF COOLING SPEED, "Y" TERMINAL MUST BE CONNECTED TO THE ROOM THERMOSTAT.
 - THESE TERMINALS PROVIDE 120V POWER CONNECTIONS FOR ELECTRONIC AIR CLEANER (EAC) AND HUMIDIFIER (HUM). MAX. LOAD: 1.0 AMPS EACH.
 - WHEN TWINNING TWO FURNACES, BOTH UNITS MUST BE CONNECTED TO THE SAME 115 VAC PHASE. CONNECT THE TWO UNITS 'TWIN' TERMINALS WITH 14 TO 22 AWG. WIRE.
 - FOR MOELS USING 3/4 HP & 1 HP INDOOR FAN MOTOR, USE DETAIL A & TABLE A.



Electrical Data

TDD1-H Wiring Diagram For Gas Furnaces

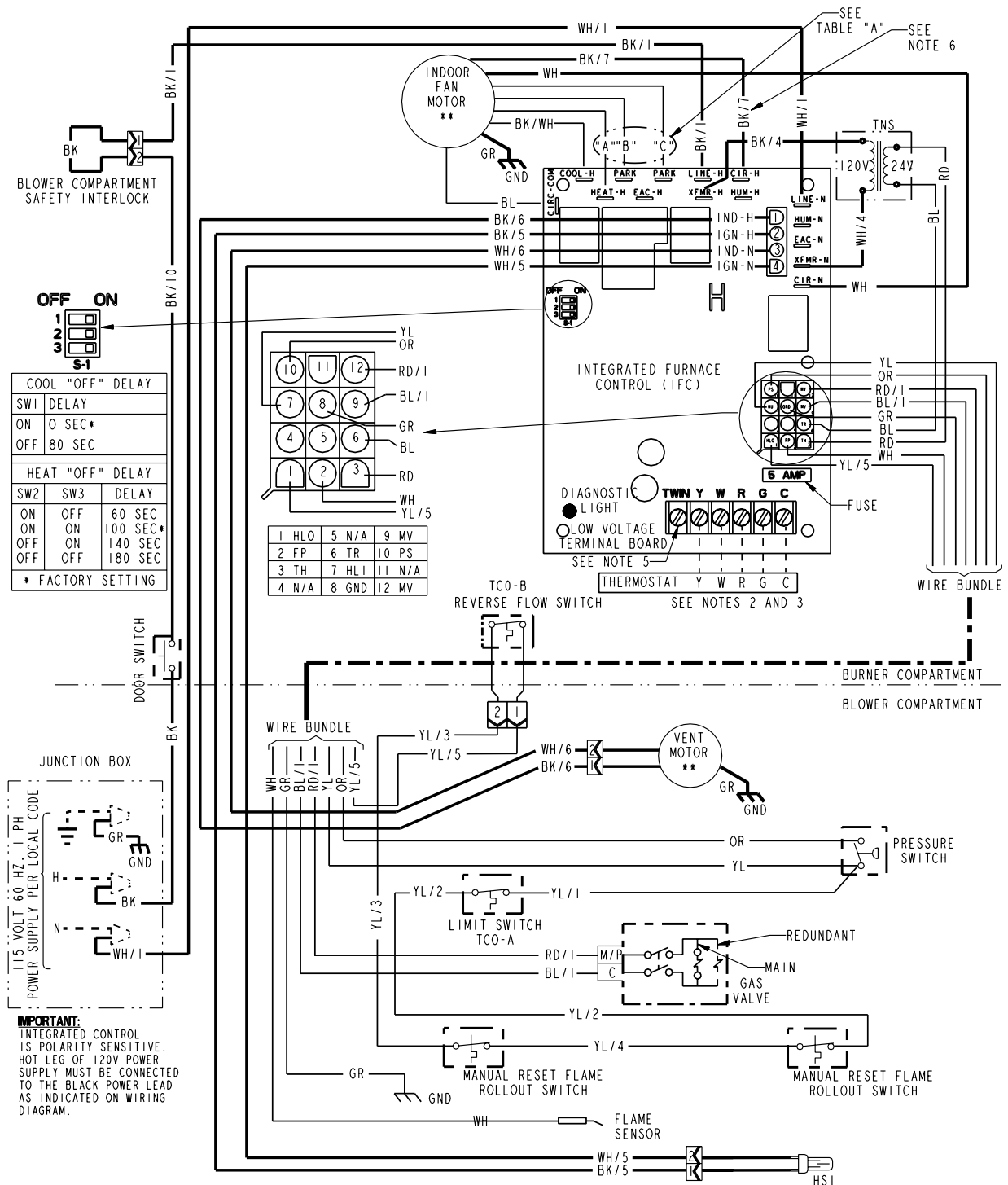

COOL "OFF" DELAY		
SW1	DELAY	
ON	0 SEC*	
OFF	80 SEC	
HEAT "OFF" DELAY		
SW2	SW3	DELAY
ON	OFF	60 SEC
ON	ON	100 SEC*
OFF	ON	140 SEC
OFF	OFF	180 SEC
* FACTORY SETTING		

1 HLO	5 N/A	9 MV
2 FP	6 TR	10 PS
3 TH	7 HLI	11 N/A
4 N/A	8 GND	12 MV

IMPORTANT:
 INTEGRATED CONTROL IS POLARITY SENSITIVE. HOT LEG OF 120V POWER SUPPLY MUST BE CONNECTED TO THE BLACK POWER LEAD AS INDICATED ON WIRING DIAGRAM.

From Dwg. D342490P03

Electrical Data

TDD1-H Schematic Diagram For Gas Furnaces

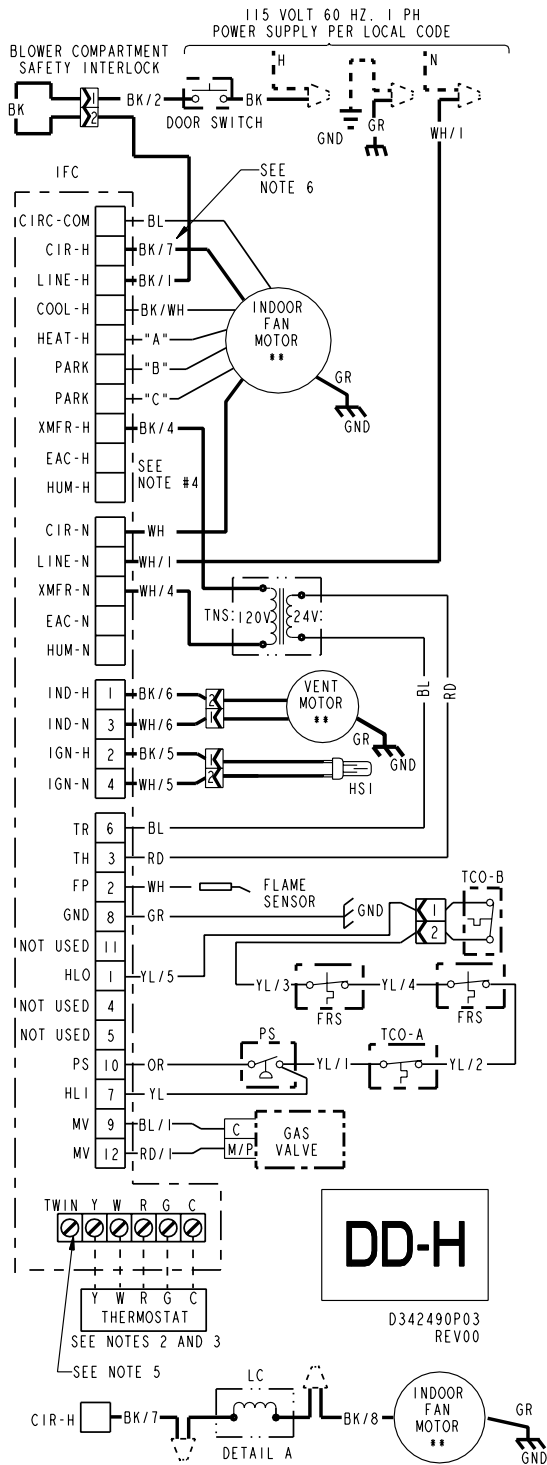

TABLE "A"
SPEED TAPS FOR I.D. FAN MOTOR

MODEL	HEAT "A"	PARK "B"	PARK "C"	BLOWER HP
*DD1B060A9H31B**	RD/WH	BL/WH	YL/WH	1/2
*DD1B080A9H31B**	RD/WH	BL/WH	YL/WH	1/2
*DD1C100A9H51B**	YL/WH	BL/WH	RD/WH	1
*DD1D120A9H51B**	YL/WH	BL/WH	RD/WH	1

* PREFIX MAY BE "A" OR "T"
** SUFFIX MAY BE "A" THROUGH "Z"
RD/WH = LOW=1 BL/WH = MED.HIGH=3
YL/WH = MED. LOW=2 BK/WH = HIGH=4

DIAGNOSTIC CODES

FLASHING SLOW: NORMAL - NO CALL FOR HEAT
FLASHING FAST: NORMAL - CALL FOR HEAT
CONTINUOUS ON: REPLACE IFC
CONTINUOUS OFF: CHECK POWER
2 FLASHES: EXTERNAL LOCKOUT (RETRIES OR RECYCLES EXCEEDED)
3 FLASHES: PRESSURE SWITCH ERROR
4 FLASHES: OPEN LIMIT DEVICE
5 FLASHES: FLAME SENSED WHEN NO FLAME SHOULD BE PRESENT
6 FLASHES: 115 VAC POWER REVERSED POLARITY OR POOR GROUNDING
7 FLASHES: GAS VALVE CIRCUIT ERROR
8 FLASHES: LOW FLAME SENSE SIGNAL
9 FLASHES: CHECK IGNITER

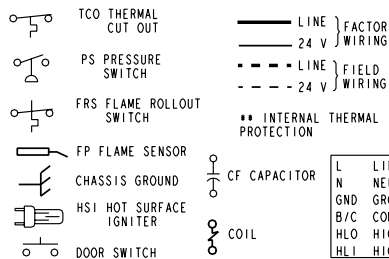

WARNING

HAZARDOUS VOLTAGE:
DISCONNECT ALL ELECTRICAL POWER INCLUDING REMOTE DISCONNECTS BEFORE SERVICING.
FAILURE TO DISCONNECT POWER BEFORE SERVICING CAN CAUSE SEVERE PERSONAL INJURY OR DEATH.

CAUTION

USE COPPER CONDUCTORS ONLY!
UNIT TERMINALS ARE NOT DESIGNED TO ACCEPT OTHER TYPES OF CONDUCTORS.
FAILURE TO DO SO MAY CAUSE DAMAGE TO THE EQUIPMENT.

INTEGRATED FURNACE CONTROL
REPLACE WITH PART CNT04711 OR EQUIVALENT

INPUT: 25 VAC, 60 HZ.
XFMR SEC. CURRENT: 450 MA.
MV OUTPUT: 1.5 A @ 24 VAC
IND OUTPUT: 2.2 FLA, 3.5 LRA @ 120 VAC
CIRC. BLOWER OUTPUT: 14.5 FLA, 14.5 LRA @ 120 VAC
HUMIDIFIER & AIR CLEANER
MAX. LOAD: 1.0 A @ 120 VAC
IGNITER OUTPUT: 2.0 A @ 120 VAC

BK	BLACK	GR	GREEN
WH	WHITE	BR	BROWN
YL	YELLOW	RD	RED
OR	ORANGE	BL	BLUE

WIRE COLOR
BK/1 NUMBER ID (IF ANY)

L	LINE	TH	24 VAC (HOT)
N	NEUTRAL	TR	24 VAC (COMMON)
GND	GROUND	MV	MAIN GAS VALVE
B/C	COMMON	TNS	TRANSFORMER
HLO	HIGH LIMIT OUTPUT		
HLI	HIGH LIMIT INPUT		

NOTES:

- IF ANY OF THE ORIGINAL WIRING AS SUPPLIED WITH THIS FURNACE MUST BE REPLACED, IT MUST BE WITH WIRE HAVING A TEMPERATURE RATING OF AT LEAST 105 C.
- THERMOSTAT HEAT ANTICIPATOR SETTING: .38 AMPS
- FOR PROPER OPERATION OF COOLING SPEED, "Y" TERMINAL MUST BE CONNECTED TO THE ROOM THERMOSTAT.
- THESE TERMINALS PROVIDE 120V POWER CONNECTIONS FOR ELECTRONIC AIR CLEANER (EAC) AND HUMIDIFIER (HUM). MAX. LOAD: 1.0 AMPS EACH.
- WHEN TWINNING TWO FURNACES, BOTH UNITS MUST BE CONNECTED TO THE SAME 115 VAC PHASE. CONNECT THE TWO UNITS 'TWIN' TERMINALS WITH 14 TO 22 AWG. WIRE.
- FOR MOELS USING 3/4 HP & 1 HP INDOOR FAN MOTOR, USE DETAIL A & TABLE A.

DD-H

D342490P03
REV00

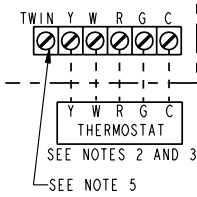



Field Wiring

FIELD WIRING DIAGRAM FOR 1 STAGE FURNACE 1 STAGE HEATING USING A 1 STAGE HEATING THERMOSTAT NO COOLING

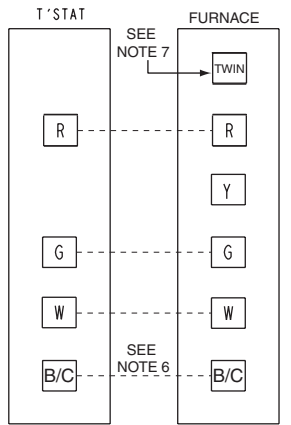

INTER-COMPONENT WIRING

----- 24 V. } FIELD WIRING
LINE V. }

----- 24 V. } FACTORY WIRING
LINE V. }

NOTES:

1. BE SURE POWER AGREES WITH EQUIPMENT NAMEPLATE(S).
2. LOW VOLTAGE (24V. WIRING) TO BE NO. 18 A.W.G. MIN.
3. GROUNDING OF EQUIPMENT MUST COMPLY WITH LOCAL CODES.
4. SET THERMOSTAT HEAT ANTICIPATOR PER UNIT WIRING DIAGRAM.
5. THESE LEADS PROVIDE 115 V. POWER FOR CONNECTION OF ELECTRONIC AIR CLEANER AND HUMIDIFIER MAX. LOAD 1.0 AMPS EACH.
6. THIS CONNECTION IS ONLY USED FOR THERMOSTATS REQUIRING CONNECTION TO THE 24 V. POWER SUPPLY. (COMMON)
7. SEE TWINNING CONNECTION DIAGRAMS FOR PROPER CONNECTIONS WHEN USING THIS FEATURE.

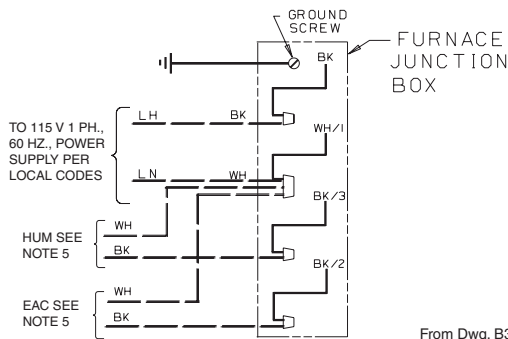

From Dwg. B341437 Rev. 1

FIELD WIRING DIAGRAM FOR 1 STAGE FURNACE 1 STAGE HEATING, 1 STAGE COOLING USING A 1 STAGE HEATING, 1 STAGE COOLING THERMOSTAT (OUTDOOR SECTION WITHOUT TRANSFORMER)

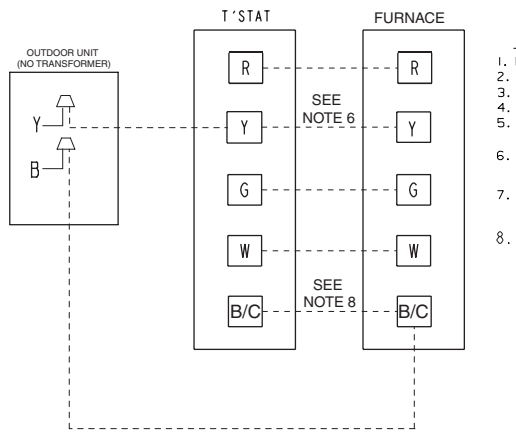

INTER-COMPONENT WIRING

----- 24 V. } FIELD WIRING
LINE V. }

----- 24 V. } FACTORY WIRING
LINE V. }

NOTES:

1. BE SURE POWER AGREES WITH EQUIPMENT NAMEPLATE(S)
2. LOW VOLTAGE(24 V. WIRING) TO BE NO. 18 A.W.G. MIN.
3. GROUNDING OF EQUIPMENT MUST COMPLY WITH LOCAL CODES.
4. SET THERMOSTAT HEAT ANTICIPATOR PER UNIT WIRING DIAGRAM.
5. THESE LEADS PROVIDE 115 V. POWER FOR CONNECTION OF ELECTRONIC AIR CLEANER AND HUMIDIFIER MAX. LOAD 1.0 AMPS EACH.
6. THE "Y" TERMINAL FROM THE THERMOSTAT MUST BE WIRED TO THE "Y" TERMINAL OF THE FURNACE CONTROL FOR PROPER BLOWER OPERATION DURING COOLING.
7. IGNITION CONTROL IS POLARITY SENSITIVE; HOT LEG OF 120 VOLT POWER SUPPLY MUST BE CONNECTED TO THE BLACK LINE POWER LEAD AS INDICATED ON THE WIRING DIAGRAM OR IGNITION LOCKOUT WILL OCCUR.
8. THIS CONNECTION IS ONLY USED FOR THERMOSTATS REQUIRING CONNECTION TO THE 24 V. POWER SUPPLY. (COMMON)

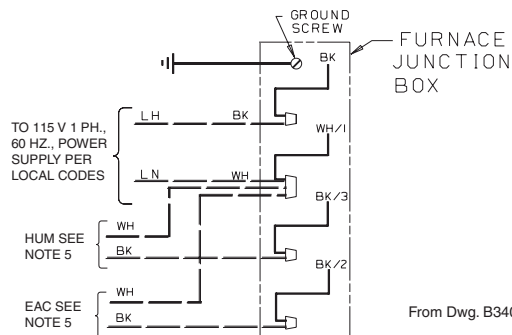

From Dwg. B340388 Rev. 2

Twinning Field Wiring

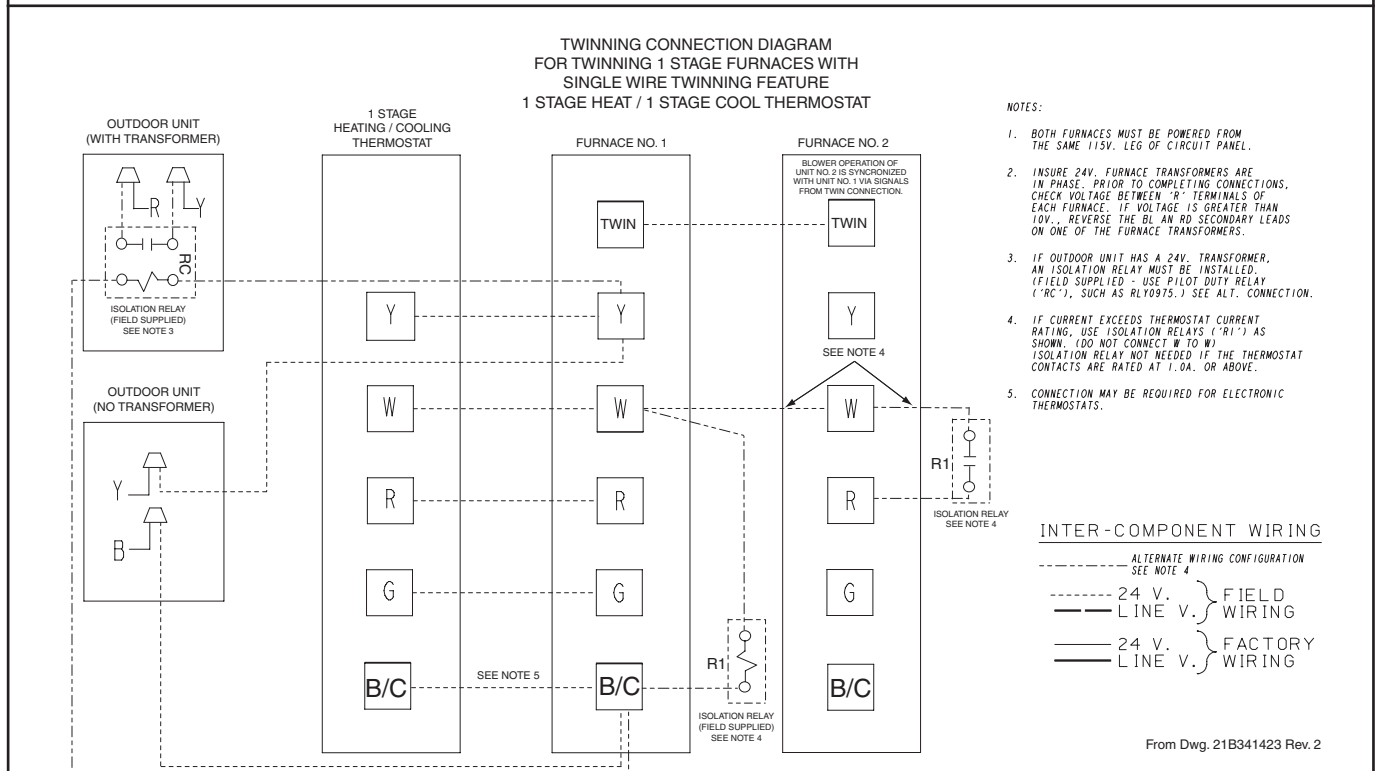
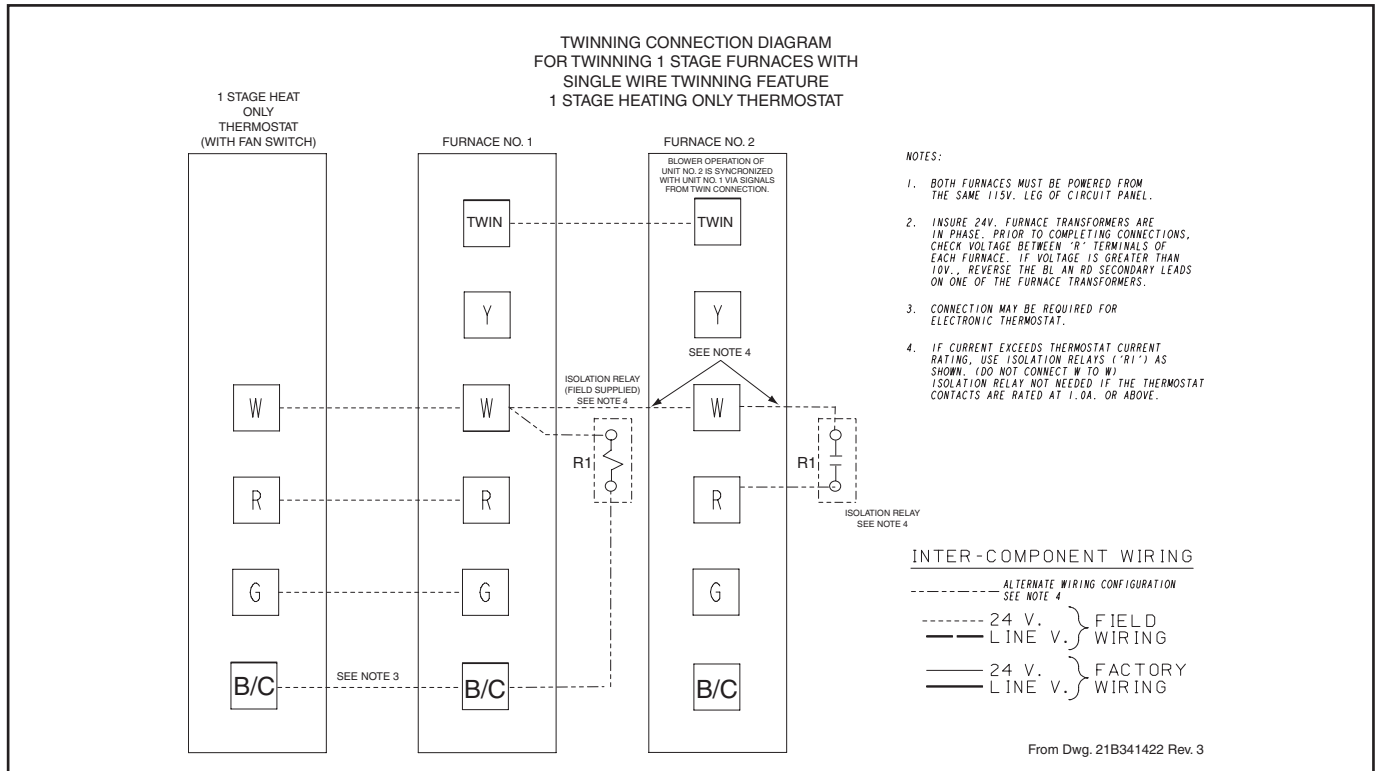

Dimensions

TUD1-H OUTLINE DRAWING (ALL DIMENSIONS ARE IN INCHES)

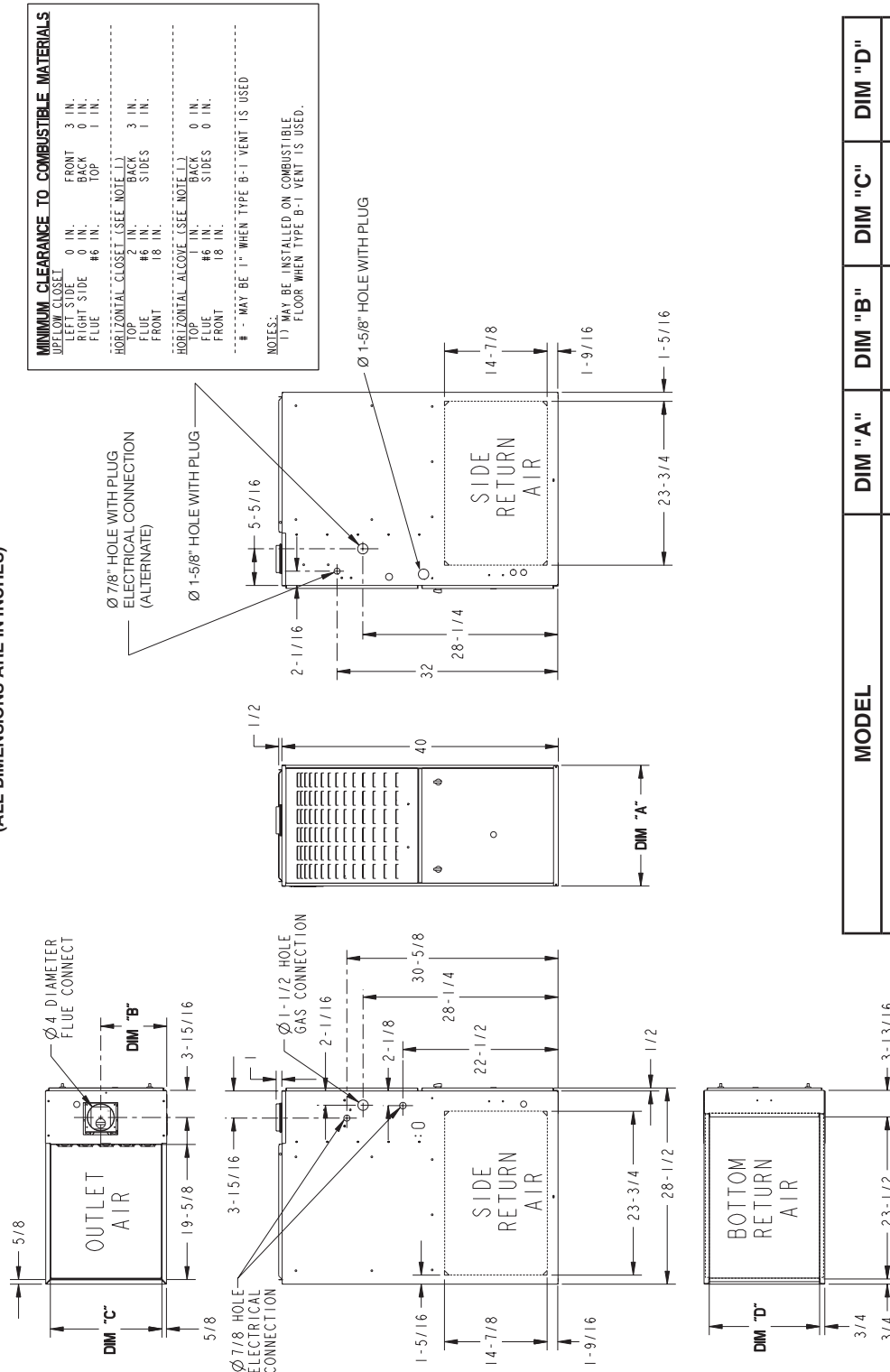

MODEL	DIM "A"	DIM "B"	DIM "C"	DIM "D"
*UD1A040A9H21B, *UD1A040G9H21A	14-1/2"	9-5/8"	13-1/4"	13"
*UD1B060A9H31B, *UD1B060G9H31A	17-1/2"	9-5/8"	16-1/4"	16"
*UD1B080A9H31B, *UD1B080G9H31A	21"	13-1/16"	19-3/4"	19-1/2"
*UD1B100A9H31B, *UD1B100G9H31A	24-1/2"	15-5/16"	23-1/4"	23"
*UD1C080A9H41B, *UD1C080G9H41A				
*UD1C100A9H51B, *UD1C100G9H51A				
*UD1D120A9H51B, *UD1D120G9H51A				
*UD1D140A9H51B, *UD1D140G9H51A				

* May be "T" or "A"

Dimensions

TDD1-H OUTLINE DRAWING (ALL DIMENSIONS ARE IN INCHES)

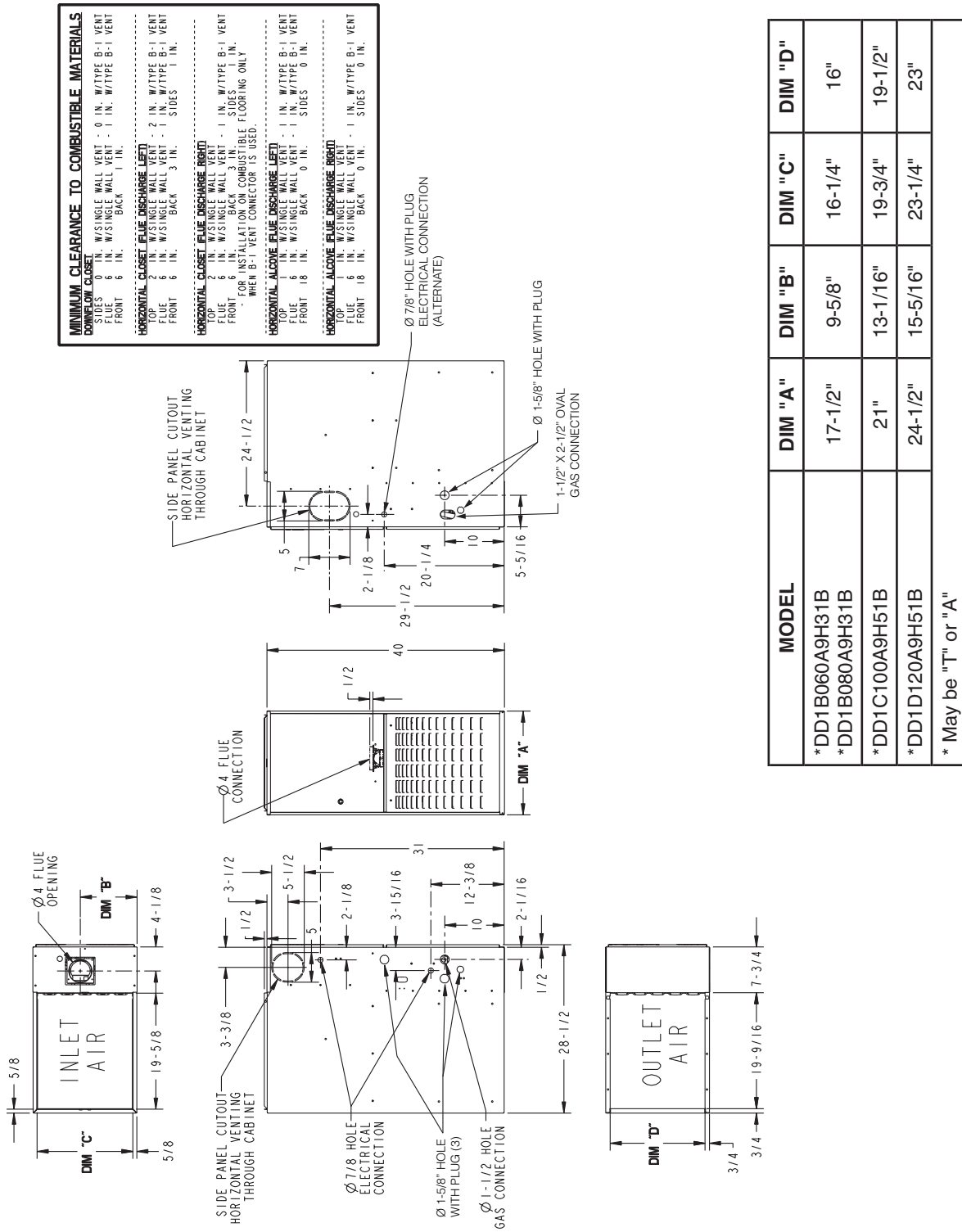



Trane
6200 Troup Highway
Tyler, TX 75707
www.trane.com

04/15

Trane has a policy of continuous product and product data improvement and it reserves the right to change design and specifications without notice.