

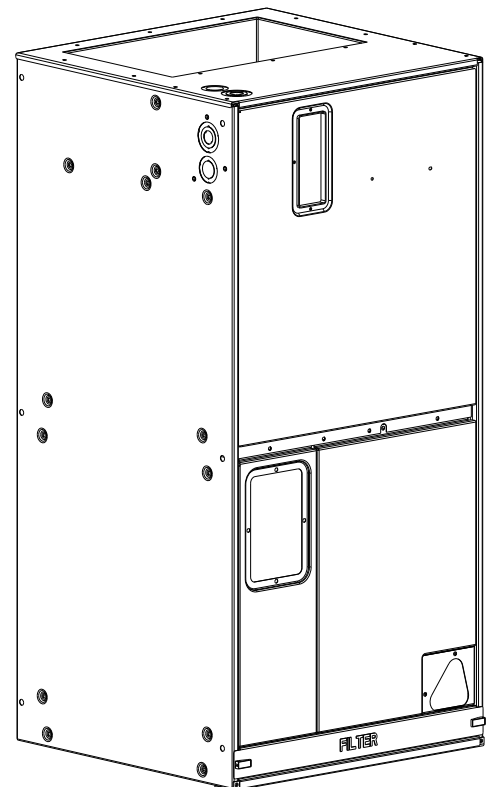

Cooling/Heat Pump Convertible Air Handlers

2/4TEH3F18B1000A
2/4TEH3F24B1000A
2/4TEH3F30B1000A
2/4TEH3F36B1000A
2/4TEH3F42C1000A
2/4TEH3F48B1000A
2/4TEH3F60B1000A

1½ – 5 Ton



PUB. NO. 22-1777-10



Features and Benefits

- 13.0 SEER
- Ships vertical — converts to horizontal by laying unit on its side.
- Six-way convertibility – horizontal (left & right), front and rear access; upflow, downflow
- “1-man” installation opportunity
- Electrical, refrigerant, condensate & blower access convertible to either side
- Compact 21" depth for easy installation
- Corrosion resistant galvanized metal with attractive finish
- Superior condensate performance
- Factory installed non-bleed TXV
- Easy Air-Tite™ access to coil
- Meets or exceeds Florida 2% leakage criteria
- Enhanced internally finned coil tubes
- Direct drive motor
- Multi-speed blower
- Versatile duct flange - allows flush fit 3/4", 1" or 1.5" duct insulation
- Filter panel stamped with word “filter”
- 200/230 volt primary & 24 volt secondary transformer
- Low voltage wire nut connections
- Insulated cabinet
- For use with BAYHTR13 or BATHTR33 series heaters ONLY
- External access to heater circuit breakers
- Polarized plugs for making electrical connections from air handler control box to heaters
- Approved for modular or manufactured homes

Selection Procedure

Model Number Nomenclature

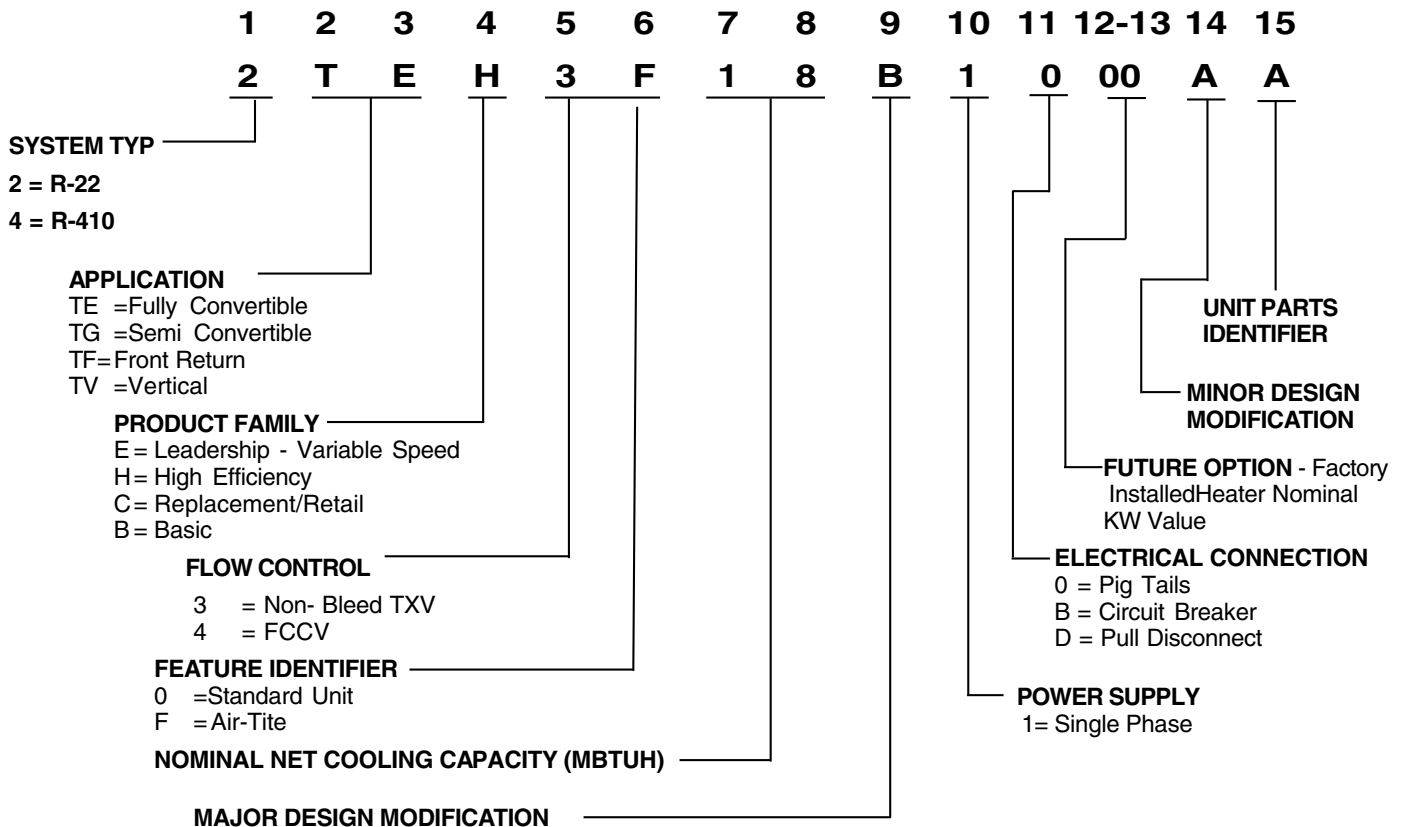

Contents

Features and Benefits	2
Selection Procedure	2
Model Number Nomenclature	2
General Data	4
2/4TEH3F18B1000A	4
2/4TEH3F24B1000A	4
2/4TEH3F30B1000A	4
2/4TEH3F36B1000A	4
2/4TEH3F42B1000A	4
2/4TEH3F48B1000A	5
2/4TEH3F60B1000A	5
Performance Data	6-9
Electrical Data	11
Field Wiring	16
2/4TEH3F18-60 Convertibility	19
Dimensions	20
Mechanical Specification Options	21



General Data

MODEL	2/4TEH3F18B1000A		2/4TEH3F24B1000A		2/4TEH3F30B1000A	
RATED VOLTS/PH/HZ.	208-230/1/60		208-230/1/60		208-230/1/60	
RATINGS ①	See O.D. Specifications		See O.D. Specifications		See O.D. Specifications	
INDOOR COIL — Type	Plate Fin		Plate Fin		Plate Fin	
Rows — F.P.I.	3 - 14		3 - 14		3 - 14	
Face Area (sq. ft.)	3.21		3.21		3.67	
Tube Size (in.)	3/8 - Copper		3/8 - Copper		3/8 - Copper	
Refrigerant Control	TXVNB ④		TXVNB ④		TXVNB ④	
Drain Conn. Size (in.) ②	3/4 NPT		3/4 NPT		3/4 NPT	
INDOOR FAN — Type	Centrifugal		Centrifugal		Centrifugal	
Diameter-Width (in.)	11 X 10		11 X 10		11 X 10	
No. Used	1		1		1	
Drive - No. Speeds	Direct - 4		Direct - 4		Direct - 4	
CFM vs. in w.g.	See Fan Performance Table		See Fan Performance Table		See Fan Performance Table	
No. Motors — H.P.	1 - 1/3		1 - 1/3		1 - 1/3	
Motor Speed R.P.M.	825		1050		1050	
Volts/Ph/Hz	208-230/1/60		208-230/1/60		208-230/1/60	
F.L. Amps - L.R. Amps	2.8		2.8		2.8	
FILTER						
Vertical Applications	Yes		Yes		Yes	
Filter Furnished?	Throwaway		Throwaway		Throwaway	
Type Recommended	1 - 20 X 20 - 1 in.		1 - 20 X 20 - 1 in.		1 - 20 X 20 - 1 in.	
No.-Size-Thickness						
Horizontal Applications	See Note ⑤		See Note ⑤		See Note ⑤	
Filter Furnished?	See Note ③		See Note ③		See Note ③	
Recommended Size ③						
REFRIGERANT	R-22	R-410A	R-22	R-410A	R-22	R-410A
Ref. Line Connections	Brazed	Brazed	Brazed	Brazed	Brazed	Brazed
Coupling or Conn. Size — in. Gas	5/8	1/2	3/4	5/8	3/4	3/4
Coupling or Conn. Size — in. Liq.	1/4	1/4	5/16	5/16	5/16	5/16
DIMENSIONS	H x W x D		H x W x D		H x W x D	
Crated (in.)	44 1/2 x 24 x 23-1/2		44 1/2 x 24 x 23-1/2		46 1/2 x 24 x 23-1/2	
Uncrated	See Outline Drawing		See Outline Drawing		See Outline Drawing	
WEIGHT						
Shipping (Lbs.) / Net (Lbs.)	121/111		121/111		135 / 125	

MODEL	2/4TEH3F36B1000A		2/4TEH3F42B1000A	
RATED VOLTS/PH/HZ.	208-230/1/60		208-230/1/60	
RATINGS ①	See O.D. Specifications		See O.D. Specifications	
INDOOR COIL — Type	Plate Fin		Plate Fin	
Rows — F.P.I.	3 - 14.0		3 - 14.0	
Face Area (sq. ft.)	3.67		5.04	
Tube Size (in.)	3/8 - Copper		3/8 - Copper	
Refrigerant Control	TXV - NonBleed ④		TXV - NonBleed ④	
Drain Conn. Size (in.) ②	3/4 NPT		3/4 NPT	
INDOOR FAN — Type	Centrifugal		Centrifugal	
Diameter-Width (in.)	11 X 10		11 X 10	
No. Used	1		1	
Drive - No. Speeds	Direct - 4		Direct - 4	
CFM vs. in w.g.	See Fan Performance Table		See Fan Performance Table	
No. Motors — H.P.	1 - 1/2		1 - 1/2	
Motor Speed R.P.M.	1050		1050	
Volts/Ph/Hz	208-230/1/60		208-230/1/60	
F.L. Amps - L.R. Amps	4.1		4.1	
FILTER				
Vertical Applications	Yes		Yes	
Filter Furnished?	Throwaway		Throwaway	
Type Recommended	1 - 20 X 20 - 1 in.		1 - 20 X 20 - 1 in.	
No.-Size-Thickness				
Horizontal Applications	See Note ⑤		See Note ⑤	
Filter Furnished?	See Note ③		See Note ③	
Recommended Size ③				
REFRIGERANT	R-22	R-410A	R-22	R-410A
Ref. Line Connections	Brazed	Brazed	Brazed	Brazed
Coupling or Conn. Size — in. Gas	7/8	3/4	7/8	3/4
Coupling or Conn. Size — in. Liq.	3/8	3/8	3/8	3/8
DIMENSIONS	H x W x D		H x W x D	
Crated (in.)	46 1/2 x 24 x 23-1/2		53 1/4 x 26 x 23-1/2	
Uncrated	See Outline Drawing		See Outline Drawing	
WEIGHT				
Shipping (Lbs.) / Net (Lbs.)	135 / 125		165 / 150	

① These Air Handlers are A.R.I. certified with various Split System Air Conditioners and Heat Pumps (ARI STANDARD 210/240). Refer to the Split System Outdoor Unit Product Data Guides for performance data.

② 3/4" Male Plastic Pipe (Ref.: ASTM 1785-76)

③ Minimum filter size for horizontal applications will be based on airflow selection and will be calculated as follows:
 Low Velocity Filter: Face area (Sq. Ft.) = CFM / 300
 High Velocity Filter: Face area (Sq. Ft.) = CFM / 500

④ Torque Spec for TXV = Tighten 1/6 turn past finger tight

⑤ For customer ease of filter maintenance, it is recommended that a properly sized remote filter and grille be installed for horizontal applications. Airflow should not exceed the face velocity of the filter being used. **The factory installed filter should then be removed from the unit.**





General Data

MODEL	2/4TEH3F48B1000A	2/4TEH3F60B1000A
RATED VOLTS/PH/HZ.	208-230/1/60	208-230/1/60
RATINGS ①	See O.D. Specifications	See O.D. Specifications
INDOOR COIL — Type	Plate Fin	Plate Fin
Rows — F.P.I.	3 - 14	3 - 14
Face Area (sq. ft.)	6.19	6.19
Tube Size (in.)	3/8 - Copper	3/8 - Copper
Refrigerant Control	TXV - NonBleed ④	TXV-NonBleed ④
Drain Conn. Size (in.) ②	3/4 NPT	3/4 NPT
INDOOR FAN — Type	Centrifugal	Centrifugal
Diameter-Width (in.)	11 X 10	11 X 10
No. Used	1	1
Drive - No. Speeds	Direct - 4	Direct - 4
CFM vs. in w.g.	See Fan Performance Table	See Fan Performance Table
No. Motors — H.P.	1 - 3/4	1 - 1
Motor Speed R.P.M.	1000	1050
Volts/Ph/Hz	208-230/1/60	208-230/1/60
F.L. Amps - L.R. Amps	6.0	7.6
FILTER		
Vertical Applications	Yes	Yes
Filter Furnished?	Throwaway	High Velocity
Type Recommended	1 - 20 X 20 - 1 in.	1 - 20 X 22 - 1 in.
No.-Size-Thickness	See Note ⑥	See Note ⑥
Horizontal Applications	See Note ③	See Note ③
Filter Furnished?	See Note ③	See Note ③
Recommended Size ③		
REFRIGERANT	R-22 R-410A	R-22 R-410A
Ref. Line Connections	Brazed Brazed	Brazed Brazed
Coupling or Conn. Size — in. Gas	1-1/8 7/8	1-1/8 7/8
Coupling or Conn. Size — in. Liq.	3/8 3/8	3/8 3/8
DIMENSIONS		
Crated (in.)	H x W x D	H x W x D
Uncrated	59-1/2 x 26 x 23-1/2 See Outline Drawing	59-1/2 x 26 x 23-1/2 See Outline Drawing
WEIGHT		
Shipping (Lbs.) / Net (Lbs.)	166 / 151	183/173

- ① These Air Handlers are A.R.I. certified with various Split System Air Conditioners and Heat Pumps (ARI STANDARD 210/240). Refer to the Split System Outdoor Unit Product Data Guides for performance data.
- ② 3/4" Male Plastic Pipe (Ref.: ASTM 1785-76)
- ③ Minimum filter size for horizontal applications will be based on airflow selection and will be calculated as follows:
 Low Velocity Filter: Face area (Sq. Ft.) = CFM / 300
 High Velocity Filter: Face area (Sq. Ft.) = CFM / 500
- ④ Torque Spec for TXV = Tighten 1/6 turn past finger tight
- ⑤ For customer ease of filter maintenance, it is recommended that a properly sized **remote filter** and grille be installed for horizontal applications. Airflow should not exceed the face velocity of the filter being used. **The factory installed filter should then be removed from the unit.**

PRESSURE DROP FOR ELECTRIC HEATERS IN AIR HANDLER MODELS

Pressure Drop for BAYHTR13/33 Series Electric Heater Racks						
BAYHTR	1305A	1308A	1310B 3310B	1315B 3315B	1319A	AIRFLOW RANGE (CFM)
HEATER SIZE (KW)	5	8	10	15	19	
AIR PRESSURE DROP (INCHES W.G.)	0.09	0.12	0.12	0.23	0.23	1800 or more
	0.06	0.08	0.08	0.14	0.14	1000-1800
	0.03	0.04	0.04	0.06	0.06	up to 1000
NOTES:	1. See product data or air handler nameplate for approved combinations of air handlers and heaters 2. Heater model number may have additional suffix digits					





Performance Data

Airflow Performance 2/4TEH3F18B: Wet coil, No Heaters																
EXTERNAL STATIC PRESSURE (in.w.g.)	AIRFLOW (CFM)															
	VERTICAL								HORIZONTAL							
	230 VOLTS				208 VOLTS				230 VOLTS				208 VOLTS			
	HIGH	M-HI	M-LO	LOW	HIGH	M-HI	M-LO	LOW	HIGH	M-HI	M-LO	LOW	HIGH	M-HI	M-LO	LOW
0	1002	854	749	652	982	857	750	633	953	829	723	617	948	825	715	627
0.1	942	810	722	578	937	820	722	568	909	775	684	554	902	772	682	555
0.2	893	752	651	499	890	762	652	487	859	717	621	476	851	714	618	480
0.3	844	687	567	421	838	694	569	411	806	657	551	403	797	653	545	406
0.4	791	623	488	346	779	624	489	346	752	598	481	341	743	592	475	333
0.5	731	563	422	269	716	558	421	281	698	541	418	283	688	532	413	257
0.6	668	506	368	180	651	498	362	191	645	487	358	209	635	474	357	171
0.7	606	452	314	62	589	442	301	33	591	435	295	84	581	417	295	60
0.8	556	396	236	-	539	385	217	-	538	383	216	-	528	361	210	-
0.9	534	331	101	-	510	321	80	-	481	330	102	-	474	304	73	-
NOTES:	With filter, no horizontal drip tray Small apex baffle Subtract 0.06" W.G. for downflow								As shipped, with filter Subtract 0.05" W.G. for horizontal left							

Airflow Performance 2/4TEH3F24B: Wet coil, No Heaters																
EXTERNAL STATIC PRESSURE (in.w.g.)	AIRFLOW (CFM)															
	VERTICAL								HORIZONTAL							
	230 VOLTS				208 VOLTS				230 VOLTS				208 VOLTS			
	HIGH	M-HI	M-LO	LOW	HIGH	M-HI	M-LO	LOW	HIGH	M-HI	M-LO	LOW	HIGH	M-HI	M-LO	LOW
0	1116	918	949	994	1116	977	957	1003	1064	953	876	914	1068	950	879	907
0.1	1067	915	852	775	1065	935	861	774	1022	893	807	734	1014	890	799	731
0.2	1015	865	768	640	1011	868	771	636	969	828	735	618	958	825	725	614
0.3	958	792	693	554	952	789	688	549	911	763	665	540	899	758	657	534
0.4	894	715	624	491	885	712	613	486	851	700	598	479	839	693	592	471
0.5	826	646	558	431	812	641	545	425	791	640	536	420	777	631	528	411
0.6	757	589	495	363	738	581	482	354	733	586	477	353	716	573	466	345
0.7	691	543	434	282	668	529	422	270	678	534	421	276	657	517	405	267
0.8	634	499	374	192	613	481	360	177	626	484	367	191	601	463	346	180
0.9	595	441	318	103	584	427	292	87	575	432	312	106	550	406	290	87
NOTES:	With filter, no horizontal drip tray Small apex baffle Subtract 0.06" W.G. for downflow								As shipped, with filter Subtract 0.05" W.G. for horizontal left							



Performance Data

Airflow Performance 2/4TEH3F30B: Wet coil, No Heaters																
EXTERNAL STATIC PRESSURE (in.w.g.)	AIRFLOW (CFM)															
	VERTICAL								HORIZONTAL							
	230 VOLTS				208 VOLTS				230 VOLTS				208 VOLTS			
	HIGH	M-HI	M-LO	LOW	HIGH	M-HI	M-LO	LOW	HIGH	M-HI	M-LO	LOW	HIGH	M-HI	M-LO	LOW
0	1271	1131	1037	955	1276	1131	1044	978	1206	1083	1005	911	1191	1084	1010	905
0.1	1223	1080	983	900	1228	1078	997	918	1168	1034	961	882	1168	1020	950	878
0.2	1178	1030	930	835	1182	1028	942	847	1127	989	912	832	1121	972	898	824
0.3	1132	979	875	768	1135	976	882	774	1085	944	858	770	1065	927	847	758
0.4	1085	924	815	700	1085	919	818	704	1043	895	800	703	1010	879	794	689
0.5	1035	867	752	637	1031	857	753	639	1000	842	739	639	962	823	738	625
0.6	982	807	688	578	971	792	689	579	956	786	679	579	920	761	678	568
0.7	926	744	627	524	907	728	629	524	910	729	623	523	878	698	618	515
0.8	870	683	578	473	840	670	578	467	861	674	576	468	827	644	563	460
0.9	816	624	547	422	770	628	538	402	808	629	542	410	752	610	520	392
NOTES:	With filter, no horizontal drip tray Small apex baffle Subtract 0.06" W.G. for downflow								As shipped, with filter Subtract 0.05" W.G. for horizontal left							

Airflow Performance 2/4TEH3F36B: Wet coil, No Heaters																
EXTERNAL STATIC PRESSURE (in.w.g.)	AIRFLOW (CFM)															
	VERTICAL								HORIZONTAL							
	230 VOLTS				208 VOLTS				230 VOLTS				208 VOLTS			
	HIGH	M-HI	M-LO	LOW	HIGH	M-HI	M-LO	LOW	HIGH	M-HI	M-LO	LOW	HIGH	M-HI	M-LO	LOW
0	1550	1396	1296	1092	1533	1386	1290	1094	1486	1341	1240	1082	1471	878	1231	1069
0.1	1511	1356	1244	1053	1497	1346	1234	1044	1448	1302	1202	1026	1384	1140	1193	1022
0.2	1472	1313	1202	1002	1453	1301	1192	990	1410	1265	1158	978	1376	1227	1150	973
0.3	1433	1269	1160	942	1406	1255	1150	931	1372	1226	1111	929	1365	1216	1102	919
0.4	1392	1225	1113	877	1362	1209	1100	865	1330	1183	1062	873	1302	1160	1051	860
0.5	1349	1179	1057	812	1319	1163	1039	794	1286	1134	1012	809	1174	1098	998	796
0.6	1303	1131	995	748	1275	1114	968	723	1240	1081	961	740	1002	1047	941	729
0.7	1256	1077	928	688	1224	1057	894	656	1194	1026	907	673	844	1007	882	663
0.8	1209	1011	863	633	1154	985	828	603	1152	976	850	620	790	956	817	602
0.9	1165	927	811	583	1054	889	788	572	1117	936	787	598	965	857	747	555
NOTES:	With filter, no horizontal drip tray Small apex baffle Subtract 0.06" W.G. for downflow								As shipped, with filter Subtract 0.05" W.G. for horizontal left							



Performance Data

Airflow Performance 2/4TEH3F42C: Wet coil, No Heaters																
EXTERNAL STATIC PRESSURE (in.w.g.)	AIRFLOW (CFM)															
	VERTICAL								HORIZONTAL							
	230 VOLTS				208 VOLTS				230 VOLTS				208 VOLTS			
	HIGH	M-HI	M-LO	LOW	HIGH	M-HI	M-LO	LOW	HIGH	M-HI	M-LO	LOW	HIGH	M-HI	M-LO	LOW
0	1586	1423	1332	1146	1568	1425	1326	1156	1544	1397	1302	1122	1518	1388	1280	1116
0.1	1545	1392	1280	1094	1526	1378	1273	1082	1501	1351	1256	1071	1479	1336	1243	1058
0.2	1504	1348	1231	1039	1481	1331	1224	1023	1461	1310	1212	1018	1438	1292	1198	1004
0.3	1462	1299	1182	982	1434	1283	1174	970	1422	1270	1166	961	1395	1249	1148	948
0.4	1418	1250	1131	921	1387	1233	1122	912	1383	1227	1119	901	1353	1205	1096	889
0.5	1373	1203	1077	859	1339	1181	1065	848	1342	1180	1068	838	1309	1156	1043	826
0.6	1325	1156	1020	795	1291	1127	1004	778	1297	1130	1014	775	1264	1102	988	760
0.7	1276	1108	961	732	1242	1070	940	706	1249	1076	958	714	1216	1046	929	695
0.8	1225	1051	902	672	1189	1012	876	642	1197	1022	899	658	1160	988	864	637
0.9	1172	978	847	617	1131	954	816	598	1141	971	842	613	1094	935	789	593
NOTES:	With filter, no horizontal drip tray Small apex baffle Subtract 0.06" W.G. for downflow								As shipped, with filter Subtract 0.05" W.G. for horizontal left							

Airflow Performance 2/4TEH3F48B: Wet coil, No Heaters																
EXTERNAL STATIC PRESSURE (in.w.g.)	AIRFLOW (CFM)															
	VERTICAL								HORIZONTAL							
	230 VOLTS				208 VOLTS				230 VOLTS				208 VOLTS			
	HIGH	M-HI	M-LO	LOW	HIGH	M-HI	M-LO	LOW	HIGH	M-HI	M-LO	LOW	HIGH	M-HI	M-LO	LOW
0	1920	1785	1573	1319	1902	1771	1569	1318	1893	1766	1524	1275	1860	1741	1520	1264
0.1	1892	1756	1524	1265	1872	1744	1515	1255	1847	1716	1485	1224	1817	1696	1478	1222
0.2	1860	1723	1486	1217	1839	1708	1475	1212	1812	1678	1449	1186	1781	1659	1441	1182
0.3	1826	1689	1452	1169	1803	1669	1439	1170	1781	1647	1413	1147	1747	1625	1405	1138
0.4	1791	1652	1415	1117	1766	1629	1399	1116	1751	1617	1375	1096	1715	1591	1367	1086
0.5	1757	1615	1371	1059	1729	1591	1352	1047	1719	1584	1333	1032	1682	1555	1325	1026
0.6	1723	1575	1320	995	1690	1552	1298	965	1683	1546	1287	958	1646	1514	1275	959
0.7	1688	1531	1261	926	1651	1509	1237	881	1644	1504	1233	883	1605	1470	1218	889
0.8	1650	1481	1200	855	1609	1455	1175	812	1601	1458	1170	824	1558	1423	1153	825
0.9	1607	1421	1141	787	1564	1382	1119	785	1559	1411	1096	802	1503	1375	1080	776
NOTES:	With filter, no horizontal drip tray Small apex baffle Subtract 0.06" W.G. for downflow								As shipped, with filter Subtract 0.05" W.G. for horizontal left							

Airflow Performance 2/4TEH3F60B: Wet coil, No Heaters																
EXTERNAL STATIC PRESSURE (in.w.g.)	AIRFLOW (CFM)															
	VERTICAL								HORIZONTAL							
	230 VOLTS				208 VOLTS				230 VOLTS				208 VOLTS			
	HIGH	M-HI	M-LO	LOW	HIGH	M-HI	M-LO	LOW	HIGH	M-HI	M-LO	LOW	HIGH	M-HI	M-LO	LOW
0	2444	2148	1963	1795	2403	2127	1947	1774	2336	2081	1900	1749	2303	2052	1887	1728
0.1	2418	2107	1923	1759	2370	2081	1905	1740	2279	2052	1871	1712	2250	2020	1849	1691
0.2	2378	2072	1888	1719	2333	2046	1865	1702	2220	2021	1840	1677	2194	1987	1813	1656
0.3	2329	2041	1853	1678	2290	2014	1828	1662	2159	1990	1807	1642	2136	1952	1779	1621
0.4	2273	2010	1817	1636	2240	1980	1790	1619	2096	1958	1773	1606	2075	1918	1744	1585
0.5	2212	1976	1779	1596	2183	1941	1749	1574	2030	1925	1737	1568	2013	1883	1706	1545
0.6	2146	1939	1737	1555	2117	1897	1706	1528	1961	1885	1699	1525	1945	1844	1666	1501
0.7	2074	1898	1692	1514	2043	1850	1659	1482	1888	1834	1659	1479	1871	1797	1624	1450
0.8	1994	1854	1646	1469	1959	1803	1609	1437	1807	1763	1616	1427	1786	1734	1580	1390
0.9	1901	1807	1599	1418	1867	1762	1555	1397	1716	1661	1569	1372	1685	1649	1535	1319
NOTES:	With filter, no horizontal drip tray Small apex baffle Subtract 0.06" W.G. for downflow								As shipped, with filter Subtract 0.05" W.G. for horizontal left							



Performance Data

Air Handler/Fan Speed Heater Matrix

Air Handler Model	Unit Position	Application	HEATER MODEL NUMBER BAYHTR					* = 1 or 3
			1305 4.80KW	1308 7.68KW	*310 9.60KW	*315 15.36KW	1319 19.20KW	
2/4TEH3F18B	Vertical	A/C or Elec. Furnace	L	L	ML	—	—	
	Upflow	Heat Pump	MH	MH	H	—	—	
	Vertical	A/C or Elec. Furnace	L	L	ML	—	—	
	Downflow	Heat Pump	MH	MH	H	—	—	
	Horizontal Left	A/C or Elec. Furnace	L	L	ML	—	—	
	Horizontal Right	A/C or Elec. Furnace	L	L	ML	—	—	
2/4TEH3F24B	Vertical	A/C or Elec. Furnace	L	L	ML	MH	—	
	Upflow	Heat Pump	ML	MH	H	H	—	
	Vertical	A/C or Elec. Furnace	L	L	ML	MH	—	
	Downflow	Heat Pump	ML	MH	H	H	—	
	Horizontal Left	A/C or Elec. Furnace	L	L	ML	MH	—	
	Horizontal Right	A/C or Elec. Furnace	L	L	ML	MH	—	
2/4TEH3F30B	Vertical	A/C or Elec. Furnace	L	L	ML	MH	—	
	Upflow	Heat Pump	L	ML	H	H	—	
	Vertical	A/C or Elec. Furnace	L	L	ML	MH	—	
	Downflow	Heat Pump	L	ML	H	H	—	
	Horizontal Left	A/C or Elec. Furnace	L	L	ML	MH	—	
	Horizontal Right	A/C or Elec. Furnace	L	L	ML	MH	—	
2/4TEH3F36B	Vertical	A/C or Elec. Furnace	L	L	ML	ML	ML	
	Upflow	Heat Pump	L	ML	MH	H	H	
	Vertical	A/C or Elec. Furnace	L	L	ML	ML	ML	
	Downflow	Heat Pump	L	ML	H	H	H	
	Horizontal Left	A/C or Elec. Furnace	L	L	ML	ML	ML	
	Horizontal Right	A/C or Elec. Furnace	L	L	ML	ML	ML	
2/4TEH3F42B	Vertical	A/C or Elec. Furnace	ML	ML	ML	ML	ML	
	Upflow	Heat Pump	ML	MH	MH	H	H	
	Vertical	A/C or Elec. Furnace	ML	ML	ML	ML	ML	
	Downflow	Heat Pump	ML	ML	MH	H	H	
	Horizontal Left	A/C or Elec. Furnace	ML	ML	ML	ML	ML	
	Horizontal Right	A/C or Elec. Furnace	ML	ML	ML	ML	ML	
2/4TEH3F48B	Vertical	A/C or Elec. Furnace	ML	ML	ML	ML	ML	
	Upflow	Heat Pump	ML	ML	ML	H	H	
	Vertical	A/C or Elec. Furnace	ML	ML	ML	ML	ML	
	Downflow	Heat Pump	ML	ML	ML	H	H	
	Horizontal Left	A/C or Elec. Furnace	ML	ML	ML	ML	ML	
	Horizontal Right	A/C or Elec. Furnace	ML	ML	ML	ML	ML	
2/4TEH3F60B	Vertical	A/C or Elec. Furnace	L	L	L	L	L	
	Upflow	Heat Pump	L	L	L	L	L	
	Vertical	A/C or Elec. Furnace	L	L	L	L	L	
	Downflow	Heat Pump	L	L	L	L	L	
	Horizontal Left	A/C or Elec. Furnace	L	L	L	L	L	
	Horizontal Right	A/C or Elec. Furnace	L	L	L	L	L	

(L)Low, (ML) Medium-Low, (MH) Medium-High, (H) High, indicate minimum heating speed settings for blower/motor operation.



Electrical Data

2/4TEH3F18B WIRING DATA Indoor Blower Motor Powered from Heater Circuit 1											
Heater Model No.	Number of Circuits/Phase	240 VOLT					208 VOLT				
		Capacity		Heater Amps per Circuit	Minimum Circuit Ampacity	Maximum Overload Protection	Capacity		Heater Amps per Circuit	Minimum Circuit Ampacity	Maximum Overload Protection
		KW	BTUH				KW	BTUH			
No Heater	-	-	-	-	4	15	-	-	-	4	15
BAYHTR1305+++A	1/1	4.80	16400	20	29	30	3.60	12300	17.3	25	25
BAYHTR1308+++A	1/1	7.68	26200	32	44	45	5.76	19700	27.7	38	40
BAYHTR1310+++B	1/1	9.60	32500	40	54	60	7.20	24600	34.6	47	50
BAYHTR3310+++B	1/3	9.60	32500	34.6	43	45	7.20	24600	30	37	40

* Circuit 1/Circuit 2 (Minimum Circuit Ampacity for Circuit 1 includes Blower Motor Amps)
 +++ = 000, PDC, BRK 000 = pigtails, PDC= contains pull disconnect, BRK=contains circuit disconnect
 IMPORTANT: Any power supply and/or combination power supply, circuit or circuits must be wired and protected in accordance with local Electrical Codes.

2/4TEH3F24B WIRING DATA Indoor Blower Motor Powered from Heater Circuit 1											
Heater Model No.	Number of Circuits/Phase	240 VOLT					208 VOLT				
		Capacity		Heater Amps per Circuit	Minimum Circuit Ampacity	Maximum Overload Protection	Capacity		Heater Amps per Circuit	Minimum Circuit Ampacity	Maximum Overload Protection
		KW	BTUH				KW	BTUH			
No Heater	-	-	-	-	4	15	-	-	-	4	15
BAYHTR1305+++A	1/1	4.80	16400	20	29	30	3.60	12300	17.3	25	25
BAYHTR1308+++A	1/1	7.68	26200	32	44	45	5.76	19700	27.7	38	40
BAYHTR1310 +++B	1/1	9.60	32800	40	54	60	7.20	24600	34.6	47	50
BAYHTR3310 +++B	1/3	9.60	32800	34.6	43	45	7.20	24600	30	37	40
BAYHTR1315 BRKB	2/1	15.36	52400	32/32	44*/40	50*/40	11.53	39300	27.7/27.7	38*/35	40*/35
BAYHTR1315 BRKB with Single Power source kit BAYSPEK140B	1/1	15.36	52400	64	89.5	90	11.53	39300	55.4	78.8	80
BAYHTR3315 000B	1/3	15.36	52400	42.3	56	60	11.53	39300	36.7	49	60

* Circuit 1/Circuit 2 (Minimum Circuit Ampacity for Circuit 1 includes Blower Motor Amps)
 +++ = 000, PDC, BRK 000 = pigtails, PDC= contains pull disconnect, BRK=contains circuit disconnects
 IMPORTANT: Any power supply and/or combination power supply, circuit or circuits must be wired and protected in accordance with local Electrical Codes.

2/4TEH3F30B WIRING DATA Indoor Blower Motor Powered from Heater Circuit 1											
Heater Model No.	Number of Circuits/Phase	240 VOLT					208 VOLT				
		Capacity		Heater Amps per Circuit	Minimum Circuit Ampacity	Maximum Overload Protection	Capacity		Heater Amps per Circuit	Minimum Circuit Ampacity	Maximum Overload Protection
		KW	BTUH				KW	BTUH			
No Heater	-	-	-	-	4	15	-	-	-	4	15
BAYHTR1305+++A	1/1	4.80	16400	20	29	30	3.60	12300	17.3	25	25
BAYHTR1308+++A	1/1	7.68	26200	32	44	45	5.76	19700	27.7	38	40
BAYHTR1310+++B	1/1	9.60	32500	40	54	60	7.20	24600	34.6	47	50
BAYHTR3310+++B	1/3	9.60	32500	34.6	43	45	7.20	24600	30	37	40
BAYHTR1315 BRKB	2/1	15.36	52400	32/32	44*/40	45*/40	11.53	39300	27.7/27.7	38*/35	40*/35
BAYHTR1315 BRKB with Single Power source kit BAYSPEK140B	1/1	15.36	52400	64	89.5	90	11.53	39300	55.4	78.75	80
BAYHTR3315 000B	1/3	15.36	52400	42.3	56	60	11.53	39300	36.7	49	50

* Circuit 1/Circuit 2 (Minimum Circuit Ampacity for Circuit 1 includes Blower Motor Amp)
 +++ = 000, PDC, BRK 000 = pigtails, PDC= contains pull disconnect, BRK=contains Circuit disconnects
 IMPORTANT: Any power supply and/or combination power supply, circuit or circuits must be wired and protected in accordance with local Electrical Codes.



Electrical Data

2/4TEH3F36B WIRING DATA Indoor Blower Motor Powered from Heater Circuit 1)											
Heater Model No.	Number of Circuits/Phase	240 VOLT					208 VOLT				
		Capacity		Heater Amps per Circuit	Minimum Circuit Ampacity	Maximum Overload Protection	Capacity		Heater Amps per Circuit	Minimum Circuit Ampacity	Maximum Overload Protection
		KW	BTUH				KW	BTUH			
No Heater	-	-	-	-	5	15	-	-	-	5	15
BAYHTR1305+++A	1/1	4.80	16400	20	30	30	3.60	12300	17.3	27	30
BAYHTR1308+++A	1/1	7.68	26200	32	45	45	5.76	19700	27.7	40	40
BAYHTR1310 +++B	1/1	9.60	32800	40	55	60	7.20	24600	34.6	48	50
BAYHTR3310 +++B	1/3	9.60	32800	34.6	43	45	7.20	24600	30	37	40
BAYHTR1315 BRKB	2/1	15.36	52400	32/32	45*/40	50*/40	11.53	39300	27.7/27.7	40*/35	40*/40
BAYHTR1315 BRKB with Single Power source kit BAYSPEK140B	1/1	15.36	52400	64	89.5	90	11.53	39300	55.4	78.75	80
BAYHTR3315 000B	1/3	15.36	52400	42.3	57	60	11.53	39300	36.7	50	50
BAYHTR1319 BRKA	2/1	19.20	65500	32/48	45*/60	50*/60	14.42	49200	27.7/41.6	40*/52	40*/60
BAYHTR1319 BRKA with Single Power source kit BAYSPEK140B	1/1	19.20	65500	80	109.5	110	14.42	49200	69.3	96.13	100

NOTES:
 * Circuit 1/Circuit 2 (Minimum Circuit Ampacity for Circuit 1 includes Blower Motor Amps)
 +++ = 000, PDC, BRK 000 = pigtails, PDC= contains pull disconnect BRK = contains circuit disconnects
 IMPORTANT: Any power supply and/or combination power supply, circuit or circuits must be wired and protected in accordance with local Electrical Codes.

2/4TEH3F42C WIRING DATA Indoor Blower Motor Powered from Heater Circuit 1)											
Heater Model No.	Number of Circuits/Phase	240 VOLT					208 VOLT				
		Capacity		Heater Amps per Circuit	Minimum Circuit Ampacity	Maximum Overload Protection	Capacity		Heater Amps per Circuit	Minimum Circuit Ampacity	Maximum Overload Protection
		KW	BTUH				KW	BTUH			
No Heater	-	-	-	-	5	15	-	-	-	5	15
BAYHTR1305+++A	1/1	4.80	16400	20	30	30	3.60	12300	17.3	27	30
BAYHTR1308+++A	1/1	7.68	26200	32	45	45	5.76	19700	27.7	40	40
BAYHTR1310 +++B	1/1	9.60	32800	40	55	60	7.20	24600	34.6	48	50
BAYHTR3310 +++B	1/3	9.60	32800	34.6	43	45	7.20	24600	30	37	40
BAYHTR1315 BRKB	2/1	15.36	52400	32/32	45*/40	50*/40	11.53	39300	27.7/27.7	40*/35	40*/40
BAYHTR1315 BRKB with Single Power source kit BAYSPEK140B	1/1	15.36	52400	64	89.5	90	11.53	39300	55.4	78.75	80
BAYHTR3315 000B	1/3	15.36	52400	42.3	57	60	11.53	39300	36.7	50	50
BAYHTR1319 BRKA	2/1	19.20	65500	32/48	45*/60	50*/60	14.42	49200	27.7/41.6	40*/52	40*/60
BAYHTR1319 BRKA with Single Power source kit BAYSPEK140B	1/1	19.20	65500	80	109.5	110	14.42	49200	69.3	96.13	100

NOTES:
 *Circuit 1/Circuit 2 (Minimum Circuit Ampacity for Circuit 1 includes Blower Motor Amps)
 +++ = 000, PDC, BRK 000 = pigtails, PDC= contains pull disconnect BRK = circuit disconnects
 IMPORTANT: Any power supply and/or combination power supply, circuit or circuits must be wired and protected in accordance with local Electrical Codes.



Electrical Data

2/4TEH3F48B WIRING DATA Indoor Blower Motor Powered from Heater Circuit 1)											
Heater Model No.	Number of Circuits/Phase	240 VOLT					208 VOLT				
		Capacity		Heater Amps per Circuit	Minimum Circuit Ampacity	Maximum Overload Protection	Capacity		Heater Amps per Circuit	Minimum Circuit Ampacity	Maximum Overload Protection
		KW	BTUH				KW	BTUH			
No Heater	-	-	-	-	8	15	-	-	-	8	15
BAYHTR1305+++A	1/1	4.80	16400	20	33	35	3.60	12300	17.3	29	30
BAYHTR1308+++A	1/1	7.68	26200	32	48	50	5.76	19700	27.7	42	45
BAYHTR1310 +++B	1/1	9.60	32800	40	58	60	7.20	24600	34.6	51	60
BAYHTR3310 +++B	1/3	9.60	32800	34.6	43	45	7.20	24600	30	37	40
BAYHTR1315 BRKB	2/1	15.36	52400	32/32	48*/40	50*/40	11.53	39300	27.7/27.7	42*/35	50*/40
BAYHTR1315 BRKB with Single Power source kit BAYSPEK140B	1/1	15.36	52400	64	89.5	90	11.53	39300	55.4	78.75	80
BAYHTR3315 000B	1/3	15.36	52400	42.3	59	60	11.53	39300	36.7	52	60
BAYHTR1319 BRKA	2/1	19.20	65500	32/48	48*/60	50*/60	14.42	49200	27.7/41.6	42*/52	50*/60
BAYHTR1319 BRKA with Single Power source kit BAYSPEK140B	1/1	19.20	65500	80	109.5	110	14.42	49200	69.3	96.13	100

NOTES:
 *Circuit 1/Circuit 2 (Minimum Circuit Ampacity for Circuit 1 includes Blower Motor Amps)
 +++ = 000, PDC, BRK 000 = pigtails, PDC= contains pull disconnect, BRK = circuit disconnects
 IMPORTANT: Any power supply and/or combination power supply, circuit or circuits must be wired and protected in accordance with local Electrical Codes.

2/4TEH3F60B WIRING DATA Indoor Blower Motor Powered from Heater Circuit 1)											
Heater Model No.	Number of Circuits/Phase	240 VOLT					208 VOLT				
		Capacity		Heater Amps per Circuit	Minimum Circuit Ampacity	Maximum Overload Protection	Capacity		Heater Amps per Circuit	Minimum Circuit Ampacity	Maximum Overload Protection
		KW	BTUH				KW	BTUH			
No Heater	-	-	-	-	9.5	15	-	-	-	9.5	15
BAYHTR1305+++A	1/1	4.80	16400	20	35	35	3.60	12300	17.3	31	35
BAYHTR1308+++A	1/1	7.68	26200	32	50	50	5.76	19700	27.7	44	45
BAYHTR1310 +++B	1/1	9.60	32800	40	60	60	7.20	24600	34.6	53	60
BAYHTR3310 +++B	1/3	9.60	32800	34.6	43	45	7.20	24600	30	37	40
BAYHTR1315 BRKB	2/1	15.36	52400	32/32	50*/40	50*/40	11.53	39300	27.7/27.7	44*/35	45*/35
BAYHTR1315 BRKB with Single Power source kit BAYSPEK140B	1/1	15.36	52400	64	89.5	90	11.53	39300	55.4	78.75	80
BAYHTR3315 000B	1/3	15.36	52400	42.3	60	60	11.53	39300	36.7	53	60
BAYHTR1319 BRKA	2/1	19.20	65500	32/48	50*/60	50*/60	14.42	49200	27.7/41.6	44*/52	45*/60
BAYHTR1319 BRKA with Single Power source kit BAYSPEK140B	1/1	19.20	65500	80	109.5	110	14.42	49200	69.3	96.13	100

NOTES:
 *Circuit 1/Circuit 2 (Minimum Circuit Ampacity for Circuit 1 includes Blower Motor Amps)
 +++ = 000, PDC, BRK 000 = pigtails, PDC= contains pull disconnect, BRK = circuit disconnects
 IMPORTANT: Any power supply and/or combination power supply, circuit or circuits must be wired and protected in accordance with local Electrical Codes.

Electrical Data

Unit Wiring Diagram 2/4TEH3F18-36B1000A

WARNING

HAZARDOUS VOLTAGE!
DISCONNECT ALL ELECTRICAL POWER INCLUDING REMOTE DISCONNECTS BEFORE SERVICING.
Failure to disconnect power before servicing can cause severe personal injury or death.

CAUTION

USE COPPER CONDUCTORS ONLY!
UNIT TERMINALS ARE NOT DESIGNED TO ACCEPT OTHER TYPES OF CONDUCTORS.
Failure to do so may cause damage to the equipment.

AIR FLOW SELECTION	
TERM	SPEED
1	LOW
2	MED-LO
3	MED-HI
4	HIGH

LEGEND

- 24 V.
- LINE V.
- ⊥ GROUND
- JUNCTION
- ⊢ CAPACITOR
- △ WIRE CONNECTOR
- TERMINAL
- ⊞ TRANSFORMER
- ⊞ FUSE
- ⊢ RELAY CONTACT NO
- ⊞ MAGNETIC COIL
- | | | |
|---|---|---|
| 1 | 2 | 3 |
|---|---|---|

 POL. PLUG FEMALE (MALE TERMINALS)
- | | | |
|---|---|---|
| 1 | 2 | 3 |
|---|---|---|

 POL. PLUG MALE (FEMALE TERMINALS)
- CN WIRE CONNECTOR
- CF FAN CAPACITOR
- F FAN RELAY
- FU FUSE
- ER ELECTRONIC RELAY
- PF POLARIZED PLUG (FEMALE HOUSING)
- PM POLARIZED PLUG (MALE HOUSING)
- TNS TRANSFORMER
- | | |
|---------|-------------------------------|
| ← BK/BL | ← BLACK WIRE WITH BLUE MARKER |
| ← BK | ← COLOR OF MARKER |
- BK BLACK
- BL BLUE
- BR BROWN
- RD RED
- WH WHITE
- YL YELLOW
- OR ORANGE
- GR GREEN
- PR PURPLE

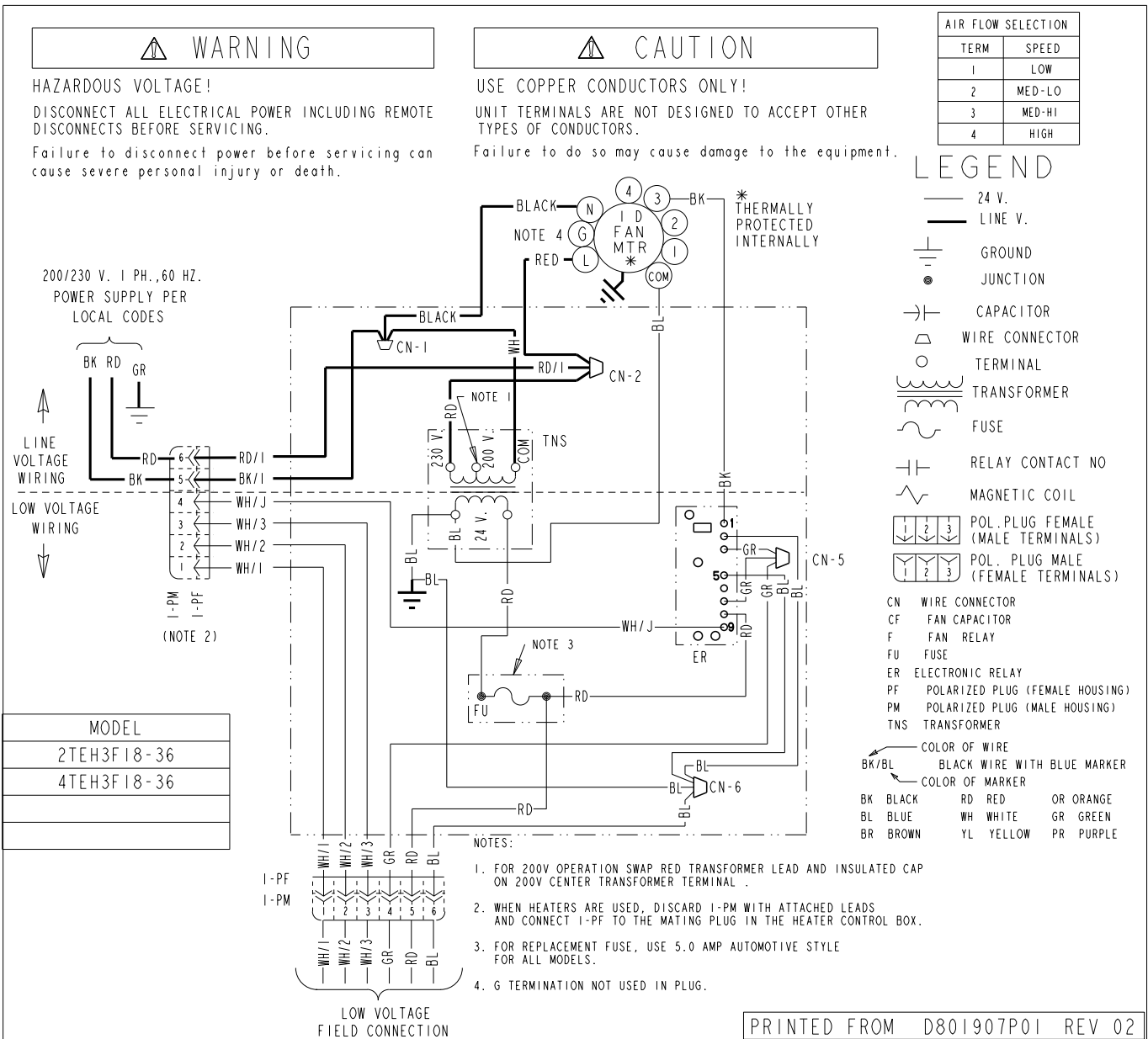



Electrical Data

Unit Wiring Diagram 2/4TEH3F42C1000A

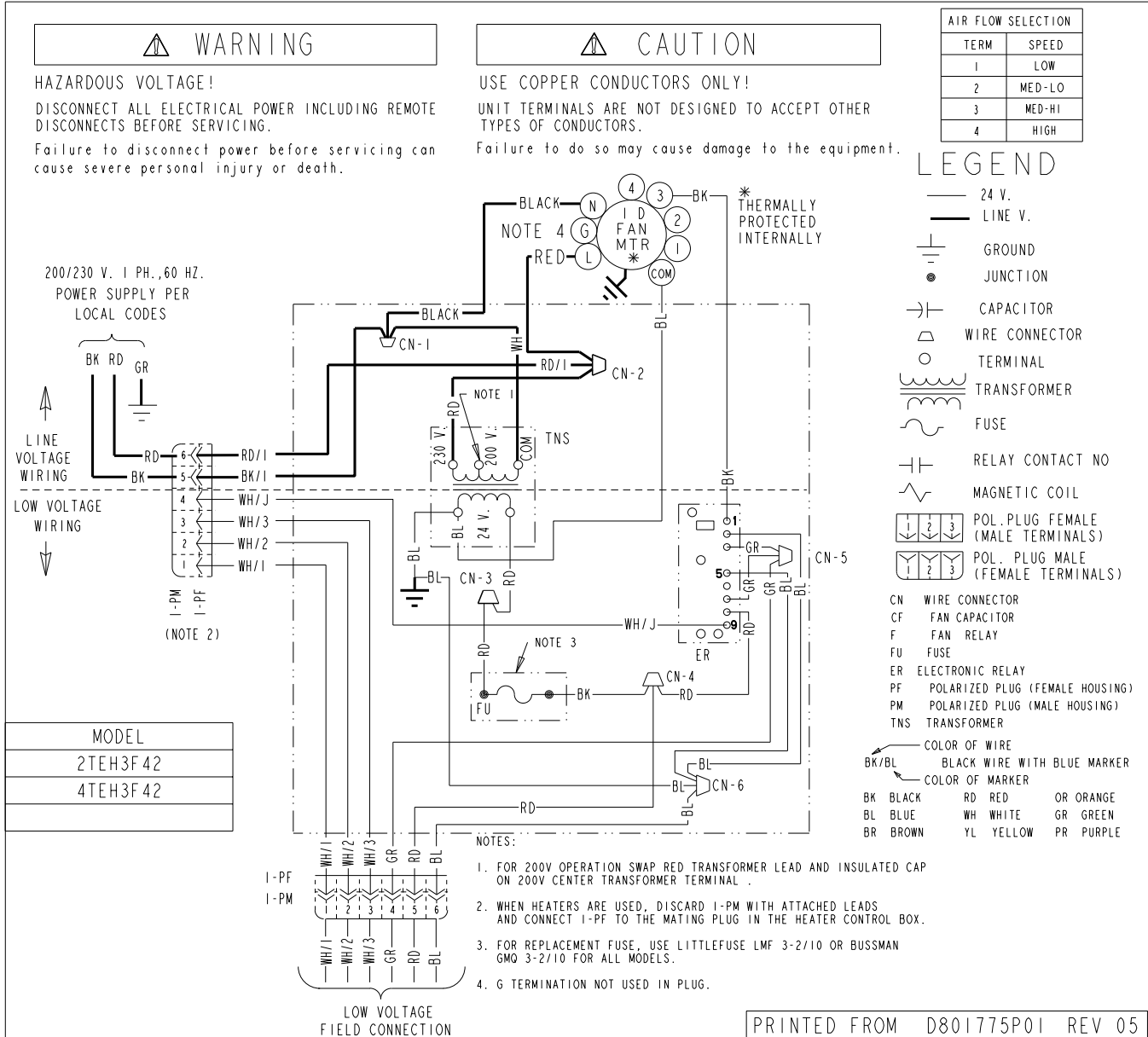

NOTE: Motor Speed Tap # 5 must be selected if a time delay function is required.

Electrical Data

Unit Wiring Diagram 2/4TEH3F48-60B1000A

WARNING

HAZARDOUS VOLTAGE!
DISCONNECT ALL ELECTRICAL POWER INCLUDING REMOTE DISCONNECTS BEFORE SERVICING.
Failure to disconnect power before servicing can cause severe personal injury or death.

CAUTION

USE COPPER CONDUCTORS ONLY!
UNIT TERMINALS ARE NOT DESIGNED TO ACCEPT OTHER TYPES OF CONDUCTORS.
Failure to do so may cause damage to the equipment.

AIR FLOW SELECTION	
TERM	SPEED
1	LOW
2	MED-LO
3	MED-HI
4	HIGH
5	MED LOW DELAY (SEE NOTE 4)

LEGEND

- 24 V.
- LINE V.
- ⊥ GROUND
- JUNCTION
- ⊢ CAPACITOR
- △ WIRE CONNECTOR
- TERMINAL
- ⎓ TRANSFORMER
- ⎓ FUSE
- ⊢ RELAY CONTACT NO
- ⎓ MAGNETIC COIL
- ⎓ POL. PLUG FEMALE (MALE TERMINALS)
- ⎓ POL. PLUG MALE (FEMALE TERMINALS)

- CN WIRE CONNECTOR
 - CF FAN CAPACITOR
 - F FAN RELAY
 - FU FUSE
 - ER ELECTRONIC RELAY
 - PF POLARIZED PLUG (FEMALE HOUSING)
 - PM POLARIZED PLUG (MALE HOUSING)
 - TNS TRANSFORMER
 - LC LINE CHOKE
- COLOR OF WIRE
BK/BL BLACK WIRE WITH BLUE MARKER
— COLOR OF MARKER
- BK BLACK
 - BL BLUE
 - BR BROWN
 - RD RED
 - WH WHITE
 - YL YELLOW
 - OR ORANGE
 - GR GREEN
 - PR PURPLE

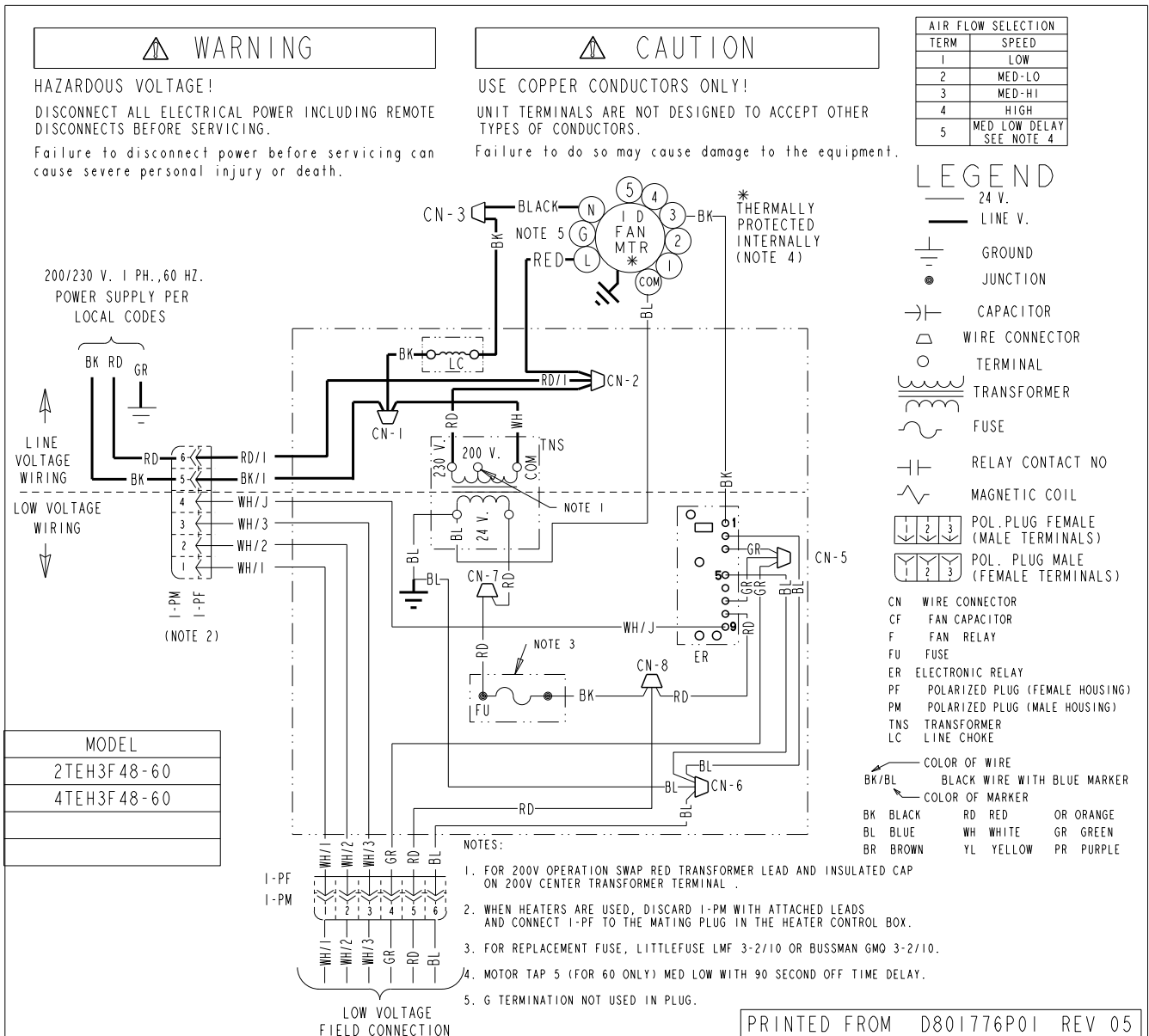

Field Wiring

Air Handler with Single Speed Cooling Unit, 2 Stage Heat

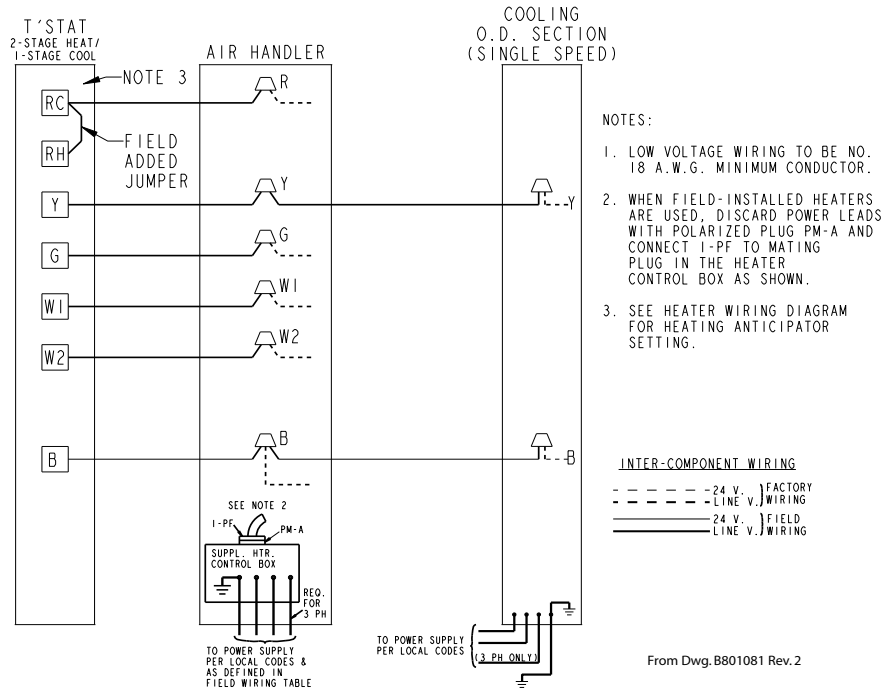

Air Handlers with Single Speed Cooling Unit, 1 Stage Heat

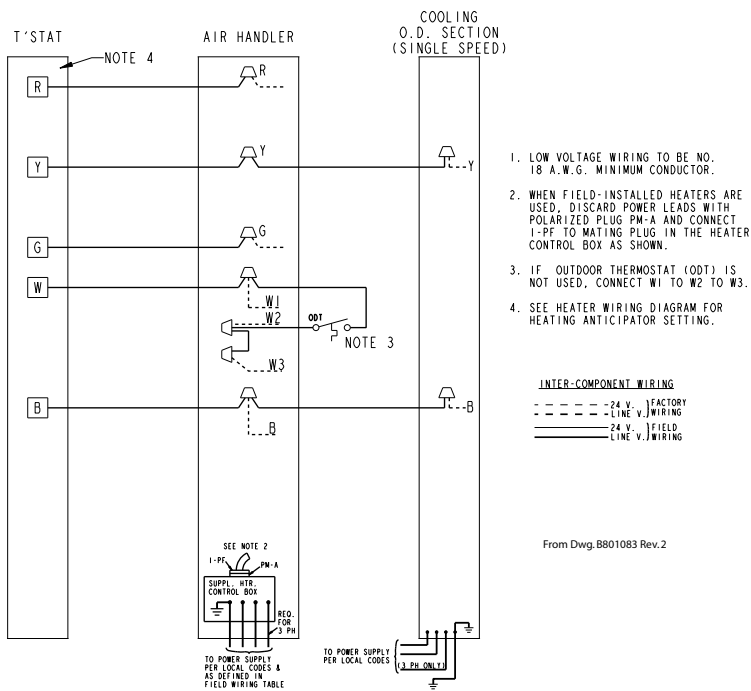

Field Wiring

Field Wiring Diagrams for Air Handlers with Heat Pump

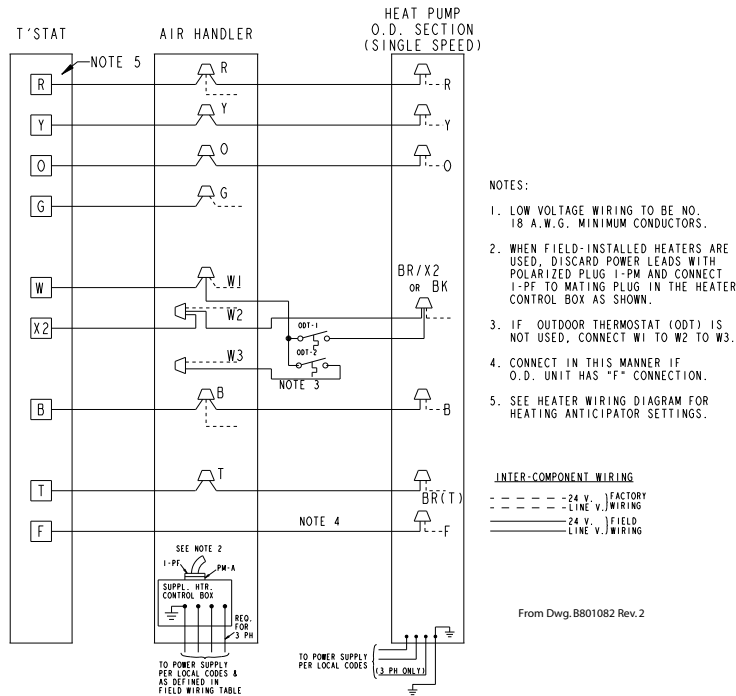

Air Handler Subbase

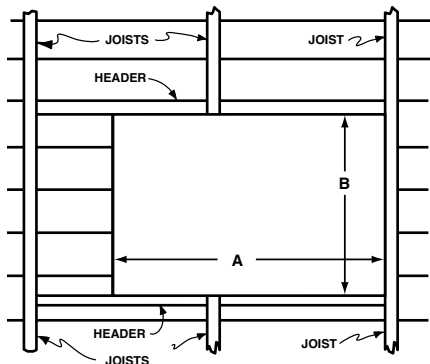

FIG. 2

FLOOR OPENING - SIZE		
MODEL NO.	A	B
TAYBASE100	23-3/4	14-13/16
TAYBASE101	21-3/4	14-13/16

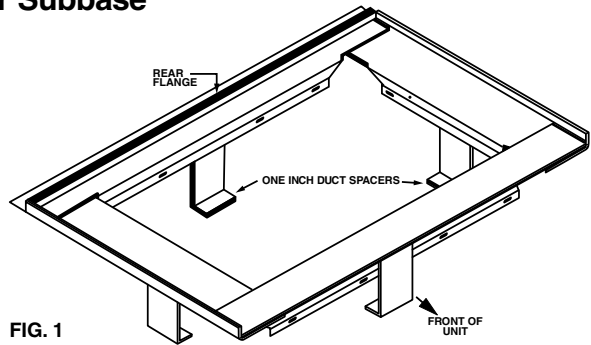

FIG. 1

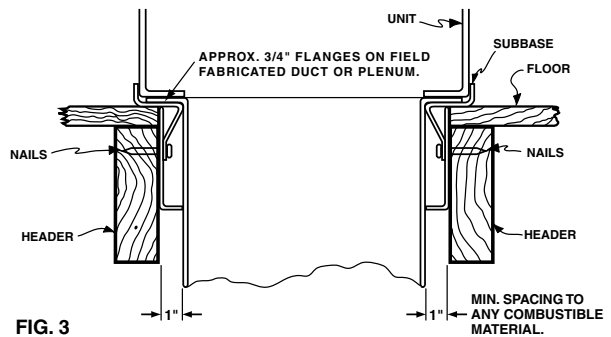

FIG. 3

2/4TEH3F18-60B1000A

Convertibility

Six (6) Way Convertibility

One Unit - 4 Applications (Conversions 1-4)

Horizontal Right (as shipped)

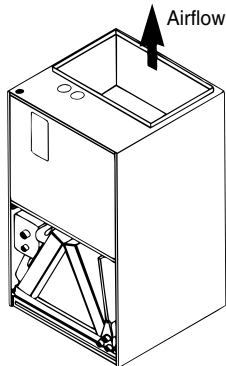
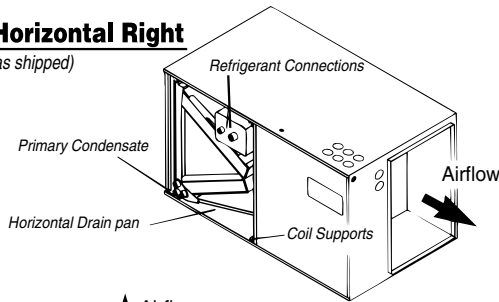

Vertical Upflow (as shipped) One-step Conversion Stand unit on end

Horizontal Left Rotate Coil

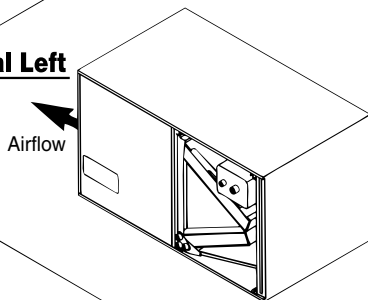

Vertical Downflow One-step Conversion from Horizontal left

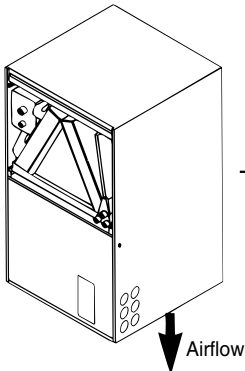

Easy Conversion to Opposite Side Access (Conversions 5 & 6)

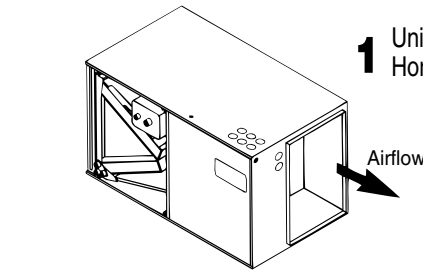

1 Unit is shipped as Horizontal right

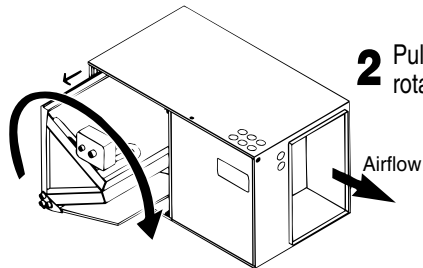

2 Pull coil out and rotate the coil 180°

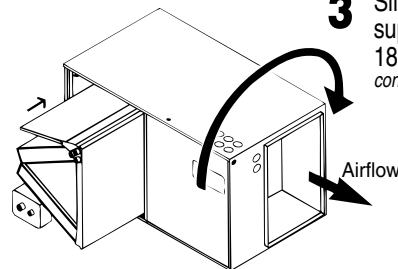

3 Slide coil back in on supports and roll unit 180° (so primary condensate is down)

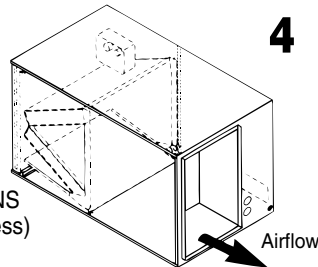

4 Note connections and access are now on back side of unit

- 6 CONVERSION APPLICATIONS
1. Horizontal Right - (Front Access)
 2. Vertical Upflow
 3. Horizontal Left - (Front Access)
 4. Vertical Downflow
 5. Horizontal Right - (Rear Access)
 6. Horizontal Left - (Rear Access)

Dimensions

Outline Drawing for 2/4TEH3F18-60B1000A

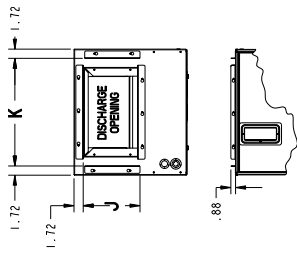

FIG. 1

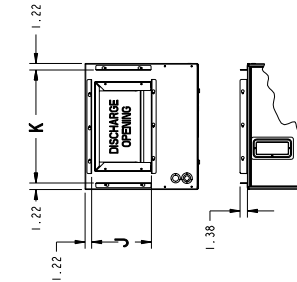
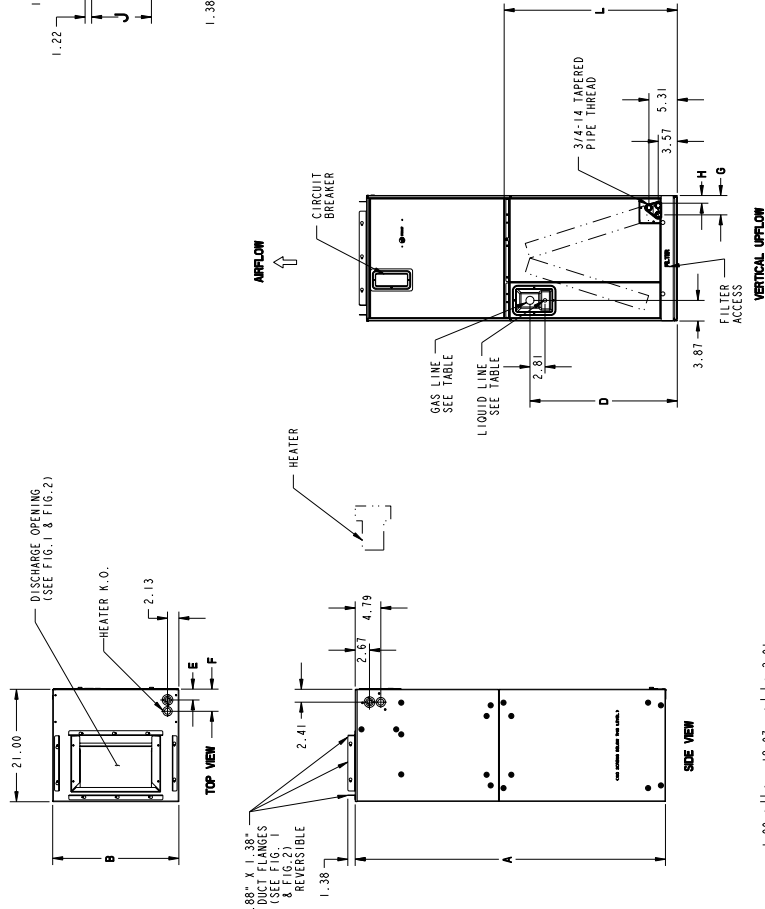

FIG. 2

MODEL NO.	FIG. 1		FIG. 2	
	J	K	J	K
2TEH3F18B, 24B, 30B, 36B	19.16	18.16		
4TEH3F18B, 24B, 30B, 36B	11.19	11.19		
2TEH3F42B, 48B, 60B	21.16	20.16		
4TEH3F42B, 48B, 60B				

MINIMUM UNIT CLEARANCE TABLE	
COMPLETABLE MATERIAL (REQUIRED)	SERVICE CLEARANCE (RECOMMENDED)
SIDES	2"
FRONT	21"
BACK	0"
INLET DUCT	0"
OUTLET DUCT	1"

* 1" FOR THE FIRST 3 FT. OF OUTLET DUCT WHEN ELECTRIC HEATERS ARE INSTALLED EXCEPT MODELS BAYTR1405, 408, AND 410 WHICH ARE DESIGNED FOR DOWNFLOW OUTLET CLEARANCE FOR UPFLOW CONFIGURATION ONLY ON TW-P MODELS.



MODEL NO.	A	B	C	D	E	F	G	H	L	FLOW CONTROL	GAS LINE BRAZE	LUB. LINE BRAZE
2TEH3F18B	43	21.50	19.50	15.57	2.00	4.12			N/A		5/8	1/4
2TEH3F24B	45	21.50	19.50	17.57	2.00	4.12					3/4	5/16
4TEH3F30B, 41E3F30B	51.75	23.50	21.50	18.33	2.17	4.29	3.62	1.89	31.15	TW/NB	7/8	3/8
2TEH3F42B	57.90	23.50	21.50	30.47	2.17	4.29	3.62	1.89	31.15	TW/NB	1-1/8	1/2
2TEH3F48B	43	21.5	19.50	15.57	2.00	4.12			N/A		5/8	5/16
4TEH3F18B	45	21.5	19.50	17.57	2.00	4.12					3/4	3/8
4TEH3F24B	51.75	23.50	21.50	30.47	2.17	4.29	3.62	1.89	31.15	TW/NB	7/8	3/8
4TEH3F42B	57.90	23.50	21.50	30.47	2.17	4.29	3.62	1.89	31.15	TW/NB	1-1/8	1/2
4TEH3F48B	43	21.5	19.50	15.57	2.00	4.12			N/A		5/8	5/16
4TEH3F60B	45	21.5	19.50	17.57	2.00	4.12					3/4	3/8

Mechanical Specification Options

General

Blower coil units shall be completely factory assembled including coil, condensate drain pan, fan, motor, filters and controls in an insulated casing that can be applied in horizontal or vertical configuration. The "F" model indicates an "Air-Tite™" model with 4.2 "R" value insulation and additional sealing systems.

This new line of 2/4TEH3F Air Handlers provides exclusive compact size combined with simple 6-way convertibility in sizes up to 5 Tons. The unit ships in the vertical upflow configuration and converts to horizontal right just by laying the unit on its side. No tools required. Simple coil rotation provides downflow and horizontal left applications.

The 6-way convertibility provides you inventory benefits and service/installation flexibility. The simple conversion provides opposite side access for installation and service.

These Air Handlers enjoy the best reputation in the industry. Superior airflow, great sound level, reliability and performance are responsible for the industry leadership. We are not about to give up such top performance.

Units shall be certified to UL Standards.

Casing

Units shall have a rugged sheet metal and steel frame construction and shall be painted with an enamel finish. Casing shall be insulated and knockouts for electrical power and control wiring.

Refrigerant Circuits

The 2/4TEH3F units have a single refrigerant circuit. 2/4TEH3F18-60 refrigerant circuit shall be controlled by a factory-installed non-bleed thermal expansion valve.

Coil

Aluminum fin surface shall be mechanically bonded to 3/8-inch OD copper tubing. Coils are factory pressure and leak tested.

Fan

Forward curved, dynamically balanced and statically balanced with 4-speed direct drive shall be standard, fan motor bearing shall be permanently lubricated.

Controls

Low voltage pig tails, fan contactor, and plug-in module for accessory electric heat control shall be included.

Filters shall be included as standard, one-inch low velocity semi-permanent type.

Accessories

Electric Heaters — Shall be available in a wide range of capacities and voltages with various staging options, and plug-in control wiring. Heaters shall fit inside the internal compartment. This product family uses only BAYHTR13 and BAYHTR33 series heaters.



04/09



Trane
6200 Troup Hwy.
Tyler, TX 75707
www.trane.com

Trane has a policy of continuous product and product data improvement and it reserves the right to change design and specifications without notice.