



Vertical Upflow Horizontal Left Air Handlers

TWG018-060A

1½ – 5 Ton



22-1695-05

Vertical Upflow Horizontal Left Air Handlers

Features:

- Full line 1 1/2 - 5 tons
- Expanded application fit with narrow cabinet profile
- Maximum depth 21" - fits pull-down staircase
- Exclusive maximum width 23.5" - fits 2-ft. wide door all sizes
- Convertible upflow to horizontal left (no tools required)
- Attractive enamel finish
- R 4.2 - 1" foil faced insulation
- Versatile duct flange - allows flush fit 3/4", 1" or 1.5" duct insulation
- Tight cabinet - low leakage by design
- IAQ (Indoor Air Quality) sloped/free draining pan (no standing water)
- Durable, glass-filled Lexan™ - Never rust, no leak drain pan
- Exclusive easy clean coil and drain pan
- Exclusive standard size replaceable fiberglass filters
- Easy to remove filters and blowers for easy cleaning and replacement
- Filter panel stamped with word "filter"
- Easy access electrical controls and hook-up
- Built-in time delay
- Direct drive motor
- Polarized plugs for easy hook-up to electric heaters
- 200/230 volt primary and 24 volt secondary transformer
- Electric heaters with breaker option on all sizes
- AccuTron™ refrigerant control
- Expansion valve (bleed TXV) standard on 5-ton model
- **Optional extended warranties**



General Data

MODEL	TWG018A140A	TWG025A140A	TWG030A140A	TWG036A140A
RATED VOLTS/PH/Hz.	200-230/1/60	200-230/1/60	200-230/1/60	200-230/1/60
RATINGS ①	See O.D. Specs	See O.D. Specs	See O.D. Specs	See O.D. Specs
INDOOR COIL — Type	Plate Fin	Plate Fin	Plate Fin	Plate Fin
Rows — F.P.I.	3 - 14	3 - 14	3 - 14	3 - 14
Face Area (sq. ft.)	1.83	2.29	2.29	2.86
Tube Size (in.)	3/8 - Copper	3/8 - Copper	3/8 - Copper	3/8 - Copper
Refrigerant Control	FCCV	FCCV	FCCV	FCCV
Drain Conn. Size (in.) ②	3/4 NPT	3/4 NPT	3/4 NPT	3/4 NPT
INDOOR FAN — Type	Centrifugal	Centrifugal	Centrifugal	Centrifugal
Diameter-Width (in.)	10 X 6	10 X 7	10 X 8	10 X 8
No. Used	1	1	1	1
Drive - No. Speeds	Direct - 3	Direct - 3	Direct - 3	Direct - 3
CFM vs. in w.g. ①	See Fan Table	See Fan Table	See Fan Table	See Fan Table
No. Motors — H.P.	1 - 1/8	1 - 1/6	1 - 1/4	1 - 1/3
Motor Speed R.P.M.	1000	1060	850	1075
Volts/Ph/Hz	200-230/1/60	200-230/1/60	200-230/1/60	200-230/1/60
F.L. Amps - L.R. Amps	1.2 - 1.9	1.15 - 1.72	2.0 - 2.86	2.1 - 5.26
FILTER				
Vertical Applications				
Filter Furnished?	YES	YES	YES	YES
Lo. Vel. (No.-Size-Thk)	1 - 14 X 20	1 - 16 X 20	1 - 16 X 20	1 - 16 X 20
Horizontal Applications				
Filter Furnished?	NO	NO	NO	NO
Recommended Size ③	See NOTE ③	See NOTE ③	See NOTE ③	See NOTE ③
REFRIGERANT (R-22)				
Ref. Line Connections	Brazed	Brazed	Brazed	Brazed
Conn. Size — in. Gas	5/8	3/4	3/4	7/8
Conn. Size — in. Liq.	1/4	5/16	5/16	3/8
DIMENSIONS	H x W x D	H x W x D	H x W x D	H x W x D
Crated (in.)				
Uncrated	43 X 16 X 21	45.7 X 18 X 21	45.7 X 18 X 21	52 X 18 X 21
WEIGHT				
Shipping (Lbs.) / Net (Lbs.)	108 / 95	124 / 109	125 / 110	135 / 119

MODEL	TWG037A140A	TWG042A140A	TWG048A140A	TWG060A150A
RATED VOLTS/PH/Hz.	200-230/1/60	200-230/1/60	200-230/1/60	200-230/1/60
RATINGS ①	See O.D. Specs	See O.D. Specs	See O.D. Specs	See O.D. Specs
INDOOR COIL — Type	Plate Fin	Plate Fin	Plate Fin	Plate Fin
Rows — F.P.I.	3 - 14	3 - 14	3 - 14	3 - 14
Face Area (sq. ft.)	2.75	3.21	4.58	5.96
Tube Size (in.)	3/8 - Copper	3/8 - Copper	3/8 - Copper	3/8 - Copper
Refrigerant Control	FCCV	FCCV	FCCV	TXVB
Drain Conn. Size (in.) ②	3/4 NPT	3/4 NPT	3/4 NPT	3/4 NPT
INDOOR FAN — Type	Centrifugal	Centrifugal	Centrifugal	Centrifugal
Diameter-Width (in.)	10 X 8	10 X 10	10 X 10	11 X 10
No. Used	1	1	1	1
Drive - No. Speeds	Direct - 3	Direct - 3	Direct - 3	Direct - 3
CFM vs. in w.g. ①	See Fan Table	See Fan Table	See Fan Table	See Fan Table
No. Motors — H.P.	1 - 1/3	1 - 1/2	1 - 1/2	1 - 1/2
Motor Speed R.P.M.	1075	1075	1075	1075
Volts/Ph/Hz	200-230/1/60	200-230/1/60	200-230/1/60	200-230/1/60
F.L. Amps - L.R. Amps	2.1 - 5.3	3.9 - 8.7	3.5 - 8.3	3.0 - 7.7
FILTER				
Vertical Applications				
Filter Furnished?	YES	YES	YES	YES
Lo. Vel. (No.-Size-Thk)	1 - 20 X 20	1 - 20 X 20	1 - 20 X 20	1 - 22 X 20
Horizontal Applications				
Filter Furnished?	NO	NO	NO	NO
Recommended Size ③	See NOTE ③	See NOTE ③	See NOTE ③	See NOTE ③
REFRIGERANT (R-22)				
Ref. Line Connections	Brazed	Brazed	Brazed	Brazed
Conn. Size — in. Gas	7/8	7/8	7/8	7/8
Conn. Size — in. Liq.	3/8	3/8	3/8	3/8
DIMENSIONS	H x W x D	H x W x D	H x W x D	H x W x D
Crated (in.)	45 X 24 X 24.5	45 X 26 X 24.5	50.25 X 26 X 24.5	59.25 X 26 X 24.5
Uncrated	43 X 21.5 X 21	43 X 23.5 X 21	48.25 X 23.5 X 21	57.25 X 23.5 X 21
WEIGHT				
Shipping (Lbs.) / Net (Lbs.)	133 / 118	136 / 120	147 / 131	188 / 169

① These Air Handlers are A.R.I. certified with various Split System Air Conditioners and Heat Pumps (ARI STANDARD 210/240). Refer to the Split System Outdoor Unit Product Data Guides for performance data.

② 3/4" Male Plastic Pipe (Ref.: ASTM 1785-76)

③ Minimum filter size for horizontal applications will be based on airflow selection and will be calculated as follows: Low Velocity Filter: Face area (Sq. Ft.) = CFM / 300
High Velocity Filter: Face area (Sq. Ft.) = CFM / 500



Performance Data

AIR FLOW PERFORMANCE TWG018A140A												
EXTERNAL STATIC PRESSURE (INCHES OF WATER)												
VERTICAL (See Notes)							HORIZONTAL (See Notes)					
230 VOLTS			208 VOLTS				230 VOLTS			208 VOLTS		
CFM	HI	MED	LO	HI	MED	LO	HI	MED	LO	HI	MED	LO
300			0.62			0.48						0.58
350			0.48			0.35			0.54			0.42
400			0.33			0.20			0.40			0.25
450		0.48	0.19		0.41	0.06		0.53	0.26		0.47	0.09
500	0.59	0.40	0.04	0.54	0.33		0.65	0.45	0.10	0.61	0.38	
550	0.49	0.31		0.45	0.24		0.54	0.37		0.50	0.29	
600	0.38	0.20		0.33	0.13		0.43	0.26		0.38	0.18	
650	0.25	0.06		0.20	0.00		0.30	0.11		0.25	0.08	
700	0.12			0.06			0.18			0.12		
750							0.05					
NOTE: Vertical - with filter, no horizontal drip tray							NOTE: Horizontal - As shipped, without filter					

AIR FLOW PERFORMANCE TWG025A140A												
EXTERNAL STATIC PRESSURE (INCHES OF WATER)												
VERTICAL (See Notes)							HORIZONTAL (See Notes)					
230 VOLTS			208 VOLTS				230 VOLTS			208 VOLTS		
CFM	HI	MED	LO	HI	MED	LO	HI	MED	LO	HI	MED	LO
500			0.53			0.39			0.58			0.44
550			0.43			0.30			0.48			0.35
600			0.32			0.19			0.37			0.24
650			0.20	0.58		0.08			0.26			0.14
700	0.53	0.51	0.08	0.50	0.43		0.60	0.54	0.15	0.57	0.45	0.02
750	0.46	0.39		0.42	0.31		0.53	0.42	0.04	0.49	0.35	
800	0.38	0.26		0.34	0.19		0.45	0.30		0.41	0.24	
850	0.31	0.13		0.26	0.06		0.38	0.17		0.33	0.14	
900	0.23	0.00		0.18			0.30	0.04		0.25	0.01	
950	0.16			0.10			0.22			0.17		
1000	0.09						0.14			0.08		
1050	0.02						0.06					
NOTE: Vertical with filter, no horizontal drip tray							NOTE: Horizontal - As shipped, without filter					



Performance Data

AIR FLOW PERFORMANCE TWG030A140A												
EXTERNAL STATIC PRESSURE (INCHES OF WATER)												
VERTICAL (See Notes)							HORIZONTAL (See Notes)					
230 VOLTS			208 VOLTS				230 VOLTS			208 VOLTS		
CFM	HI	MED	LO	HI	MED	LO	HI	MED	LO	HI	MED	LO
750						0.41						0.50
800			0.49			0.28			0.56			0.37
850	0.59	0.43	0.24	0.53	0.35	0.10	0.66	0.51	0.34	0.64	0.39	0.22
900	0.48	0.34	0.00	0.43	0.26		0.57	0.41	0.10	0.55	0.30	0.06
950	0.37	0.25		0.33	0.17		0.47	0.30		0.45	0.21	
1000	0.26	0.15		0.22	0.07		0.37	0.19		0.34	0.10	
1050	0.15	0.02		0.11			0.26	0.06		0.22		
1100	0.04			0.00			0.15			0.09		
1150							0.02					
NOTE: Vertical with filter, no horizontal drip tray							NOTE: Horizontal - As shipped, without filter					

AIR FLOW PERFORMANCE TWG036A140A												
EXTERNAL STATIC PRESSURE (INCHES OF WATER)												
VERTICAL (See Notes)							HORIZONTAL (See Notes)					
230 VOLTS			208 VOLTS				230 VOLTS			208 VOLTS		
CFM	HI	MED	LO	HI	MED	LO	HI	MED	LO	HI	MED	LO
850			0.59									
900		0.55	0.54	0.65	0.49	0.38			0.53			0.44
950	0.62	0.51	0.47	0.59	0.44	0.31		0.52	0.47		0.47	0.35
1000	0.56	0.45	0.39	0.52	0.36	0.20	0.66	0.47	0.40	0.65	0.39	0.23
1050	0.48	0.38	0.29	0.45	0.26	0.03	0.60	0.41	0.31	0.58	0.30	0.06
1100	0.40	0.29	0.17	0.36	0.14		0.53	0.34	0.21	0.50	0.19	
1150	0.32	0.19	0.04	0.27	0.00		0.45	0.27	0.09	0.40	0.08	
1200	0.23	0.07		0.17			0.36	0.19		0.30		
1250	0.13			0.06			0.26	0.10		0.18		
1300	0.02						0.15			0.06		
1350							0.02					
NOTE: Vertical with filter, no horizontal drip tray							NOTE: Horizontal - As shipped, without filter					



Performance Data

AIR FLOW PERFORMANCE TWG037A140A												
EXTERNAL STATIC PRESSURE (INCHES OF WATER)												
VERTICAL (See Notes)							HORIZONTAL (See Notes)					
230 VOLTS			208 VOLTS				230 VOLTS			208 VOLTS		
CFM	HI	MED	LO	HI	MED	LO	HI	MED	LO	HI	MED	LO
850			0.59									
900		0.55	0.54	0.65	0.49	0.38			0.53			0.44
950	0.62	0.51	0.47	0.59	0.44	0.31		0.52	0.47		0.47	0.35
1000	0.56	0.45	0.39	0.52	0.36	0.20	0.66	0.47	0.40	0.65	0.39	0.23
1050	0.48	0.38	0.29	0.45	0.26	0.03	0.60	0.41	0.31	0.58	0.30	0.06
1100	0.40	0.29	0.17	0.36	0.14		0.53	0.34	0.21	0.50	0.19	
1150	0.32	0.19	0.04	0.27	0.00		0.45	0.27	0.09	0.40	0.08	
1200	0.23	0.07		0.17			0.36	0.19		0.30		
1250	0.13			0.06			0.26	0.10		0.18		
1300	0.02						0.15			0.06		
1350							0.02					
NOTE: Vertical with filter, no horizontal drip tray							NOTE: Horizontal - As shipped, without filter					

AIR FLOW PERFORMANCE TWG042A140A												
EXTERNAL STATIC PRESSURE (INCHES OF WATER)												
VERTICAL (See Notes)							HORIZONTAL (See Notes)					
230 VOLTS			208 VOLTS				230 VOLTS			208 VOLTS		
CFM	HI	MED	LO	HI	MED	LO	HI	MED	LO	HI	MED	LO
1150		0.53	0.30		0.42	0.20		0.59	0.37		0.49	0.24
1200	0.59	0.47	0.27	0.51	0.37	0.15		0.53	0.33		0.44	0.20
1250	0.52	0.41	0.19	0.46	0.31	0.07	0.61	0.47	0.25	0.55	0.38	0.12
1300	0.46	0.34	0.05	0.40	0.24		0.55	0.40	0.11	0.49	0.31	
1350	0.39	0.26		0.33	0.16		0.48	0.32		0.42	0.23	
1400	0.32	0.18		0.26	0.08		0.41	0.24		0.35	0.15	
1450	0.25	0.09		0.19			0.34	0.15		0.28	0.06	
1500	0.17	0.00		0.11			0.26	0.06		0.20		
1550	0.09			0.03			0.18			0.12		
1600	0.01						0.10			0.04		
1650							0.01					
NOTE: Vertical with filter, no horizontal drip tray							NOTE: Horizontal - As shipped, without filter					



Performance Data

AIR FLOW PERFORMANCE TWG048A140A												
EXTERNAL STATIC PRESSURE (INCHES OF WATER)												
VERTICAL (See Notes)							HORIZONTAL (See Notes)					
230 VOLTS			208 VOLTS				230 VOLTS			208 VOLTS		
CFM	HI	MED	LO	HI	MED	LO	HI	MED	LO	HI	MED	LO
1250			0.37			0.27			0.42			0.32
1300			0.34			0.24			0.39			0.29
1350		0.53	0.29		0.44	0.19			0.34		0.52	0.24
1400	0.54	0.49	0.22	0.49	0.40	0.11		0.55	0.27	0.57	0.48	0.17
1450	0.49	0.43	0.14	0.43	0.34	0.02	0.58	0.50	0.19	0.52	0.42	0.09
1500	0.43	0.37	0.03	0.37	0.29		0.52	0.44	0.08	0.47	0.36	0.00
1550	0.37	0.31		0.31	0.22		0.46	0.37		0.41	0.30	
1600	0.31	0.24		0.25	0.15		0.40	0.30		0.34	0.23	
1650	0.24	0.17		0.18	0.08		0.33	0.23		0.27	0.16	
1700	0.17	0.09		0.10			0.26	0.15		0.20	0.08	
1750	0.10	0.01		0.02			0.19	0.07		0.13		
1800	0.02						0.11			0.05		
1850							0.03					
NOTE: Vertical with filter, no horizontal drip tray							NOTE: Horizontal - As shipped, without filter					

AIR FLOW PERFORMANCE TWG060A150A												
EXTERNAL STATIC PRESSURE (INCHES OF WATER)												
VERTICAL (See Notes)							HORIZONTAL (See Notes)					
230 VOLTS			208 VOLTS				230 VOLTS			208 VOLTS		
CFM	HI	MED	LO	HI	MED	LO	HI	MED	LO	HI	MED	LO
1500						0.39						0.37
1550						0.31						0.31
1600						0.22						0.23
1650					0.53	0.11					0.52	0.12
1700			0.39		0.44				0.45		0.44	0.00
1750		0.59	0.30	0.53	0.34				0.34	0.52	0.35	
1800	0.63	0.54	0.20	0.46	0.24			0.59	0.23	0.44	0.25	
1850	0.59	0.48	0.08	0.37	0.13		0.59	0.49	0.10	0.35	0.14	
1900	0.54	0.41		0.28	0.02		0.51	0.38		0.25	0.00	
1950	0.47	0.33		0.18			0.42	0.27		0.14		
2000	0.40	0.23		0.06			0.33	0.14		0.03		
2050	0.32	0.13					0.24	0.01				
2100	0.23	0.01					0.14					
2150	0.13						0.04					
2200	0.02											
NOTE: Vertical with filter, no horizontal drip tray							NOTE: Horizontal - As shipped, without filter					



Performance Data

MODULAR AIR HANDLER		HEATER MODEL NUMBER BAYHTR---					
MODEL NUMBER	APPLICATION	1405 4.80kw	1408 7.68kw	1410 3410 9.60kw	1415 3415 15.36kw	1419 19.20kw	1425 24.96kw
NUMBER OF HEATER RACKS		1	1	2	3	4	5
TWG018A	A/C or Elec. Furnace	L	L	L	N/A	N/A	N/A
	Heat Pump	L	M	H	N/A	N/A	N/A
TWG025A	A/C or Elec. Furnace	L	L	L	L	N/A	N/A
	Heat Pump	L	M	M	H	N/A	N/A
TWG030A TWG036A TWG037A	A/C or Elec. Furnace	L	L	L	L	N/A	N/A
	Heat Pump	L	L	L	M	N/A	N/A
TWG042A	A/C or Elec. Furnace	L	L	L	L	N/A	N/A
	Heat Pump	L	L	L	H	N/A	N/A
TWG048A	A/C or Elec. Furnace	L	L	L	L	L	N/A
	Heat Pump	L	L	L	H	H	N/A
TWG060A	A/C or Elec. Furnace	L	L	L	L	L	L
	Heat Pump	L	L	L	L	M	H

(L)Low, (M)Medium, (H)High Indicate minimum heating speed setting for blower/motor operation N/A = Not Applicable (RBR,BRK) After Heater Number indicates Heater with Circuit Breaker(s)

AIRFLOW CFM	NUMBER OF RACKS				
	1	2	3	4	5
	AIR PRESSURE DROP INCHES W.G.				
600	0.01	0.02	0.02		
700	0.01	0.02	0.02		
800	0.02	0.03	0.03	0.04	
900	0.03	0.03	0.04	0.05	
1000	0.04	0.04	0.05	0.06	
1100	0.04	0.05	0.06	0.07	0.08
1200	0.05	0.06	0.07	0.08	0.09
1300	0.06	0.07	0.08	0.09	0.11
1400	0.07	0.08	0.10	0.11	0.13
1500	0.08	0.09	0.11	0.13	0.15
1600	0.09	0.10	0.12	0.15	0.17
1700	0.10	0.11	0.14	0.17	0.19
1800	0.11	0.13	0.16	0.19	0.21
1900	0.13	0.15	0.18	0.21	0.23
2000	0.14	0.17	0.20	0.23	0.26

PRESSURE DROP FOR ELECTRIC HEATERS IN AIR HANDLER MODELS

HEATER RACKS	
HEATER MODEL NO.	NO. OF RACKS
BAYHTR1405	1
BAYHTR1408	2
BAYHTR1/3410	2
BAYHTR1/3415	3
BAYHTR1419	4
BAYHTR1425	5



Performance Data

TWG018A WIRING DATA (Indoor Blower Motor Powered from Heater Circuit 1)											
Heater Model No.	Number of Circuits/Phase	240 VOLT					208 VOLT				
		Capacity		Heater Amps per Circuit	Minimum Circuit Ampacity	Maximum Overload Protection	Capacity		Heater Amps per Circuit	Minimum Circuit Ampacity	Maximum Overload Protection
		KW	BTUH				KW	BTUH			
BAYHTR1405 +++	1/1	4.80	16400	20	27	30	3.60	12300	17.3	23	25
BAYHTR1408 +++	1/1	7.68	26200	32	42	45	5.76	19700	27.7	36	40
BAYHTR1410 +++	1/1	9.60	32800	40	52	60	7.20	24600	34.6	45	45
BAYHTR3410 000	1/3	9.60	32800	34.6	43	45	7.20	24600	30	37	40

NOTES:
 * Circuit 1/Circuit 2 (Minimum Circuit Ampacity for Circuit 1 includes Blower Motor Amps)
 +++ = 000, BRK, PDC 000 = pigtails, BRK = contains circuit breakers, PDC = contains pull disconnect
 IMPORTANT: Any power supply and/or combination power supply, circuit or circuits must be wired and protected in accordance with local Electrical Codes.

TWG025A WIRING DATA (Indoor Blower Motor Powered from Heater Circuit 1)											
Heater Model No.	Number of Circuits/Phase	240 VOLT					208 VOLT				
		Capacity		Heater Amps per Circuit	Minimum Circuit Ampacity	Maximum Overload Protection	Capacity		Heater Amps per Circuit	Minimum Circuit Ampacity	Maximum Overload Protection
		KW	BTUH				KW	BTUH			
BAYHTR1405 +++	1/1	4.80	16400	20	26	30	3.60	12300	17.3	23	25
BAYHTR1408 +++	1/1	7.68	26200	32	41	45	5.77	19700	27.7	36	40
BAYHTR1410+++	1/1	9.60	32800	40	51	60	7.21	24600	34.7	45	45
BAYHTR3410 000	1/1	9.60	32800	34.6	43	45	7.21	24600	30	37	40
BAYHTR1415 BRK	2/1	15.36	52400	44/20	51*/30	60*/30	11.52	39300	38.2/17.3	45*/26	45*/30
BAYHTR3415 000	1/3	15.36	52400	38.2	49	50	11.52	39300	33.1	43	45

NOTES:
 * Circuit 1/Circuit 2 (Minimum Circuit Ampacity for Circuit 1 includes Blower Motor Amps)
 +++ = 000, BRK, PDC 000 = pigtails, BRK = contains circuit breakers, PDC = contains pull disconnect
 IMPORTANT: Any power supply and/or combination power supply, circuit or circuits must be wired and protected in accordance with local Electrical Codes.

TWG030A WIRING DATA (Indoor Blower Motor Powered from Heater Circuit 1)											
Heater Model No.	Number of Circuits/Phase	240 VOLT					208 VOLT				
		Capacity		Heater Amps per Circuit	Minimum Circuit Ampacity	Maximum Overload Protection	Capacity		Heater Amps per Circuit	Minimum Circuit Ampacity	Maximum Overload Protection
		KW	BTUH				KW	BTUH			
BAYHTR1405 +++	1/1	4.80	16400	20	28	30	3.60	12300	17.3	24	25
BAYHTR1408 +++	1/1	7.68	26200	32	43	45	5.77	19700	27.7	37	40
BAYHTR1410 +++	11	9.60	32800	40	53	60	7.20	24600	34.6	46	50
BAYHTR3410 000	1/3	9.60	32800	34.6	43	45	7.20	24600	30	37	40
BAYHTR1415 BRK	2/1	15.36	52400	40/24	53*/30	60*/30	11.53	39300	34.6/20.8	46*/26	50*/30
BAYHTR3415 000	1/3	15.36	52400	38.2	50	50	11.53	39300	33.1	43	45

NOTES:
 * Circuit 1/Circuit 2 (Minimum Circuit Ampacity for Circuit 1 includes Blower Motor Amps)
 +++ = 000, BRK, PDC 000 = pigtails, BRK = contains circuit breakers, PDC = contains pull disconnect
 IMPORTANT: Any power supply and/or combination power supply, circuit or circuits must be wired and protected in accordance with local Electrical Codes.



Performance Data

TWG036A / TWG037A WIRING DATA (Indoor Blower Motor Powered from Heater Circuit 1)											
Heater Model No.	Number of Circuits/Phase	240 VOLT					208 VOLT				
		Capacity		Heater Amps per Circuit	Minimum Circuit Ampacity	Maximum Overload Protection	Capacity		Heater Amps per Circuit	Minimum Circuit Ampacity	Maximum Overload Protection
		KW	BTUH				KW	BTUH			
BAYHTR1405 +++	1/1	4.80	16400	20	28	30	3.60	12300	17.3	24	25
BAYHTR1408 +++	1/1	7.68	26200	32	43	45	5.77	19700	27.7	37	40
BAYHTR1410 +++	1/1	9.60	32800	40	53	60	7.20	24600	34.6	46	50
BAYHTR3410 000	1/3	9.60	32800	34.6	43	45	7.20	24600	30	37	40
BAYHTR1415 BRK	2/1	15.36	52400	40/24	53*/30	60*/30	11.53	39300	34.6/20.8	46*/26	50*/30
BAYHTR3415 000	1/3	15.36	52400	38.2	50	50	11.53	39300	33.1	44	45

NOTES:
 * Circuit 1/Circuit 2 (Minimum Circuit Ampacity for Circuit 1 includes Blower Motor Amps)
 +++ = 000, BRK, PDC 000 = pigtails, BRK = contains circuit breakers, PDC = contains pull disconnect
 IMPORTANT: Any power supply and/or combination power supply, circuit or circuits must be wired and protected in accordance with local Electrical Codes.

TWG042A WIRING DATA (Indoor Blower Motor Powered from Heater Circuit 1)											
Heater Model No.	Number of Circuits/Phase	240 VOLT					208 VOLT				
		Capacity		Heater Amps per Circuit	Minimum Circuit Ampacity	Maximum Overload Protection	Capacity		Heater Amps per Circuit	Minimum Circuit Ampacity	Maximum Overload Protection
		KW	BTUH				KW	BTUH			
BAYHTR1405 +++	1/1	4.80	16400	20	30	30	3.60	12300	17.3	27	30
BAYHTR1408 +++	1/1	7.68	26200	32	45	45	5.76	19700	27.7	40	40
BAYHTR1410 +++	1/1	9.60	32800	40	55	60	7.20	24600	34.6	48	50
BAYHTR3410 000	1/3	9.60	32800	34.6	43	45	7.20	24600	30	37	40
BAYHTR1415 BRK	2/1	15.36	52400	40/24	55*/30	60*/30	11.53	39300	34.6/20.8	48*/26	50*/30
BAYHTR3415 000	1/3	15.36	52400	38.2	52	60	11.53	39300	33.1	45	45

NOTES:
 * Circuit 1/Circuit 2 (Minimum Circuit Ampacity for Circuit 1 includes Blower Motor Amps)
 +++ = 000, BRK, PDC 000 = pigtails, BRK = contains circuit breakers, PDC = contains pull disconnect
 IMPORTANT: Any power supply and/or combination power supply, circuit or circuits must be wired and protected in accordance with local Electrical Codes.

TWG048A WIRING DATA (Indoor Blower Motor Powered from Heater Circuit 1)											
Heater Model No.	Number of Circuits/Phase	240 VOLT					208 VOLT				
		Capacity		Heater Amps per Circuit	Minimum Circuit Ampacity	Maximum Overload Protection	Capacity		Heater Amps per Circuit	Minimum Circuit Ampacity	Maximum Overload Protection
		KW	BTUH				KW	BTUH			
BAYHTR1405 +++	1/1	4.80	16400	20	29	30	3.60	12300	17.3	26	30
BAYHTR1408 +++	1/1	7.68	26200	32	44	45	5.77	19700	27.7	39	40
BAYHTR1410 +++	1/1	9.60	32800	40	54	60	7.20	24600	34.6	48	50
BAYHTR3410 000	1/3	9.60	32800	34.6	43	45	7.20	24600	30	37	40
BAYHTR1415 BRK	2/1	15.36	52400	40/24	54*/30	60*/30	11.53	39300	34.6/20.8	48*/26	50*/30
BAYHTR3415 000	1/3	15.36	52400	38.2	51	60	11.53	39300	33.1	45	45
BAYHTR1419 BRK	2/1	19.20	65500	32/48	44*/60	45*/60	14.42	49200	27.7/41.6	39*/52	40*/60

NOTES:
 * Circuit 1/Circuit 2 (Minimum Circuit Ampacity for Circuit 1 includes Blower Motor Amps)
 +++ = 000, BRK, PDC 000 = pigtails, BRK = contains circuit breakers, PDC = contains pull disconnect
 IMPORTANT: Any power supply and/or combination power supply, circuit or circuits must be wired and protected in accordance with local Electrical Codes.

Performance Data

TWG060A WIRING DATA (Indoor Blower Motor Powered from Heater Circuit *)											
Heater Model No.	Number of Circuits/Phase	240 VOLT					208 VOLT				
		Capacity		Heater Amps per Circuit	Minimum Circuit Ampacity	Maximum Overload Protection	Capacity		Heater Amps per Circuit	Minimum Circuit Ampacity	Maximum Overload Protection
		KW	BTUH				KW	BTUH			
BAYHTR1405 +++	1/1	4.80	16400	20	29	30	3.60	12300	17.3	25	25
BAYHTR1408 +++	1/1	7.68	26200	32	44	45	5.77	19700	27.7	38	40
BAYHTR1410 +++	1/1	9.60	32800	40	54	60	7.20	24600	34.6	47	50
BAYHTR3410 000	1/3	9.60	32800	34.6	43	45	7.20	24600	30	37	40
BAYHTR1415 BRK	2/1	15.36	52400	40/24	54*/30	60*/30	11.53	39300	34.6/20.8	47*/26	50*/30
BAYHTR3415 000	1/3	15.36	52400	38.2	51	60	11.53	39300	33.1	45	45
BAYHTR1419 BRK	2/1	19.20	65500	32/48	44*/60	45*/60	14.42	49200	27.7/41.6	38*/52	40*/60
BAYHTR1425 BRK	3/1	24.96	85200	44/40/20	55/54*/25	60/60*/25	18.73	69300	38.1/34.6/17.3	48/47*/22	50/50*/25

NOTES:
 * Circuit 1/Circuit 2 (Minimum Circuit Ampacity for Circuit 1 includes Blower Motor Amps)
 +++ = 000, BRK, PDC 000 = pigtails, BRK = contains circuit breakers, PDC = contains pull disconnect
 IMPORTANT: Any power supply and/or combination power supply, circuit or circuits must be wired and protected in accordance with local Electrical Codes.

Field Wiring

TWE-G AIR HANDLERS WITH SINGLE SPEED COOLING

WARNING

HAZARDOUS VOLTAGE!
 DISCONNECT ALL ELECTRICAL POWER INCLUDING REMOTE DISCONNECTS BEFORE SERVICING.
 Failure to disconnect power before servicing can cause severe personal injury or death.

CAUTION

USE COPPER CONDUCTORS ONLY!
 UNIT TERMINALS ARE NOT DESIGNED TO ACCEPT OTHER TYPES OF CONDUCTORS.
 Failure to do so may cause damage to the equipment.

ALL PHASES OF THIS INSTALLATION MUST COMPLY WITH NATIONAL, STATE AND LOCAL CODES.

NOTES:

1. LOW VOLTAGE WIRING TO BE 18 AWG MINIMUM CONDUCTORS.
2. WHEN HEATERS ARE USED, DISCARD POWER LEADS WITH POLARIZED PLUG 1-PM AND CONNECT 1-PF TO MATING PLUG IN THE HEATER CONTROL BOX AS SHOWN.
3. SET "HA" PER CURRENT THRU W1, W2, SHOWN ON WIRING DIAGRAM.

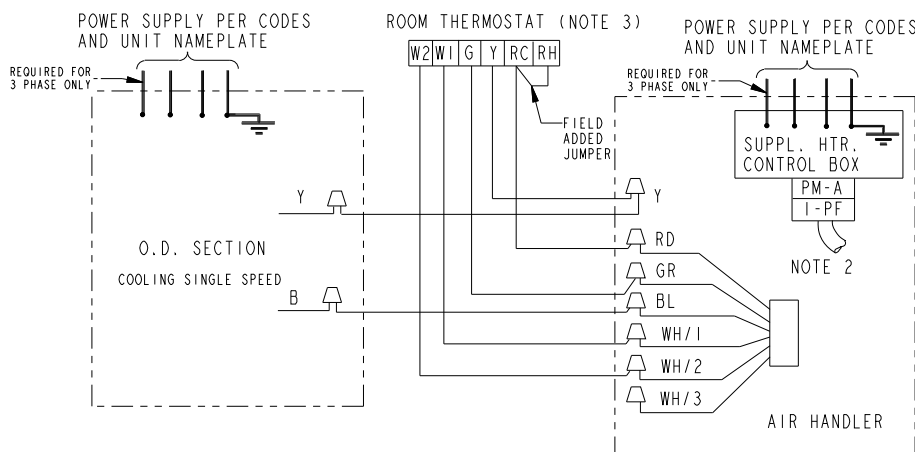

From Dwg. 21B810092 Rev. 0

Field Wiring

TWE-G AIR HANDLERS WITH SINGLE SPEED COOLING UNIT, 1 STAGE HEAT

⚠ WARNING

HAZARDOUS VOLTAGE!
DISCONNECT ALL ELECTRICAL POWER INCLUDING REMOTE DISCONNECTS BEFORE SERVICING.
Failure to disconnect power before servicing can cause severe personal injury or death.

⚠ CAUTION

USE COPPER CONDUCTORS ONLY!
UNIT TERMINALS ARE NOT DESIGNED TO ACCEPT OTHER TYPES OF CONDUCTORS.
Failure to do so may cause damage to the equipment.

ALL PHASES OF THIS INSTALLATION MUST COMPLY WITH NATIONAL, STATE AND LOCAL CODES.

NOTES:

1. LOW VOLTAGE WIRING TO BE 18 AWG MINIMUM CONDUCTORS.
2. WHEN HEATERS ARE USED, DISCARD POWER LEADS WITH POLARIZED PLUG 1-PM AND CONNECT 1-PF TO MATING PLUG IN THE HEATER CONTROL BOX AS SHOWN.
3. IF OUTDOOR THERMOSTAT (ODT) IS NOT USED, CONNECT W1 TO W2 AND W3.
4. SEE HEATER WIRING DIAGRAM FOR HEATING ANTICIPATOR SETTING.

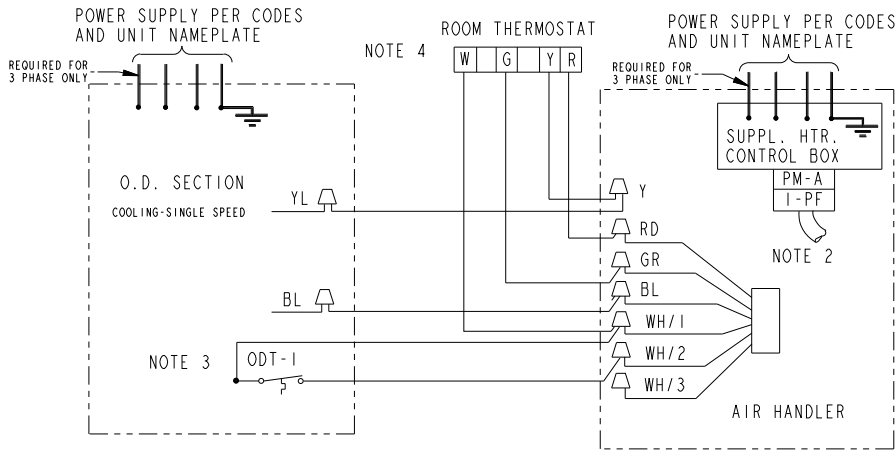

From Dwg. 21B810091 Rev. 0

FIELD WIRING DIAGRAMS FOR AIR HANDLERS WITH HEAT PUMP

⚠ WARNING

HAZARDOUS VOLTAGE!
DISCONNECT ALL ELECTRICAL POWER INCLUDING REMOTE DISCONNECTS BEFORE SERVICING.
Failure to disconnect power before servicing can cause severe personal injury or death.

⚠ CAUTION

USE COPPER CONDUCTORS ONLY!
UNIT TERMINALS ARE NOT DESIGNED TO ACCEPT OTHER TYPES OF CONDUCTORS.
Failure to do so may cause damage to the equipment.

ALL PHASES OF THIS INSTALLATION MUST COMPLY WITH NATIONAL, STATE AND LOCAL CODES.

NOTES:

1. LOW VOLTAGE WIRING TO BE 18 AWG MINIMUM CONDUCTORS.
2. WHEN HEATERS ARE USED, DISCARD POWER LEADS WITH POLARIZED PLUG 1-PM AND CONNECT 1-PF TO MATING PLUG IN THE HEATER CONTROL BOX AS SHOWN.
3. IF OUTDOOR THERMOSTAT (ODT) IS NOT USED, CONNECT W1 TO W2 AND W3.
4. CONNECT IN THIS MANNER IF OD UNIT HAS "F" CONNECTION.

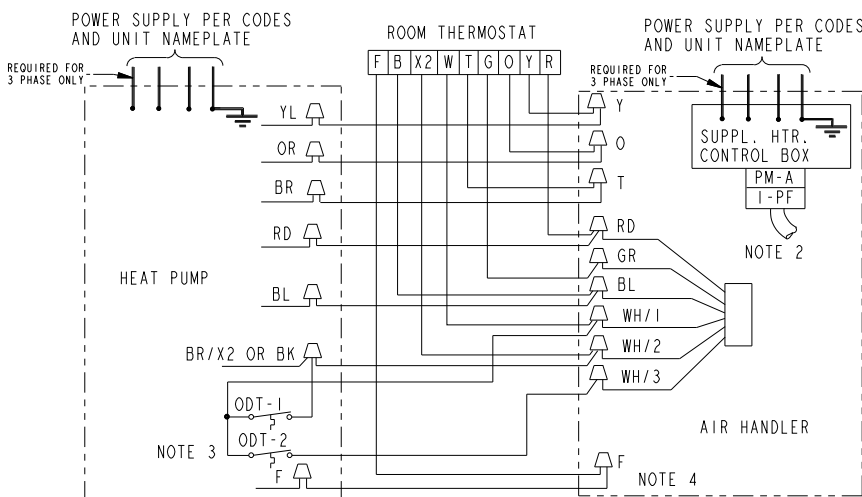

From Dwg. 21B810093 Rev. 0

Electrical Data

Unit Wiring Diagrams

WARNING

HAZARDOUS VOLTAGE!
DISCONNECT ALL ELECTRICAL POWER INCLUDING REMOTE DISCONNECTS BEFORE SERVICING.
Failure to disconnect power before servicing can cause severe personal injury or death.

CAUTION

USE COPPER CONDUCTORS ONLY!
UNIT TERMINALS ARE NOT DESIGNED TO ACCEPT OTHER TYPES OF CONDUCTORS.
Failure to do so may cause damage to the equipment.

AIR FLOW SELECTION	
TERM	SPEED
A	LOW
B	MED
C	HIGH

LEGEND

- 24 V.
- LINE V.
- ⊥ GROUND
- JUNCTION
- ⊢ CAPACITOR
- △ WIRE CONNECTOR
- TERMINAL
- ⊞ TRANSFORMER
- ⊞ FUSE
- ⊢ RELAY CONTACT NO
- ⊞ MAGNETIC COIL
- | | | |
|---|---|---|
| 1 | 2 | 3 |
| ↓ | ↓ | ↓ |

 POL. PLUG FEMALE (MALE TERMINALS)
- | | | |
|---|---|---|
| 1 | 2 | 3 |
| ↑ | ↑ | ↑ |

 POL. PLUG MALE (FEMALE TERMINALS)

- CN WIRE CONNECTOR
- CF FAN CAPACITOR
- F FAN RELAY
- FU FUSE
- PCB PRINTED CIRCUIT BOARD
- PF POLARIZED PLUG (FEMALE HOUSING)
- PM POLARIZED PLUG (MALE HOUSING)
- TNS TRANSFORMER
- COLOR OF WIRE
- BLACK WIRE WITH BLUE MARKER
- COLOR OF MARKER
- BK BLACK RD RED OR ORANGE
- BL BLUE WH WHITE GR GREEN
- BR BROWN YL YELLOW PR PURPLE

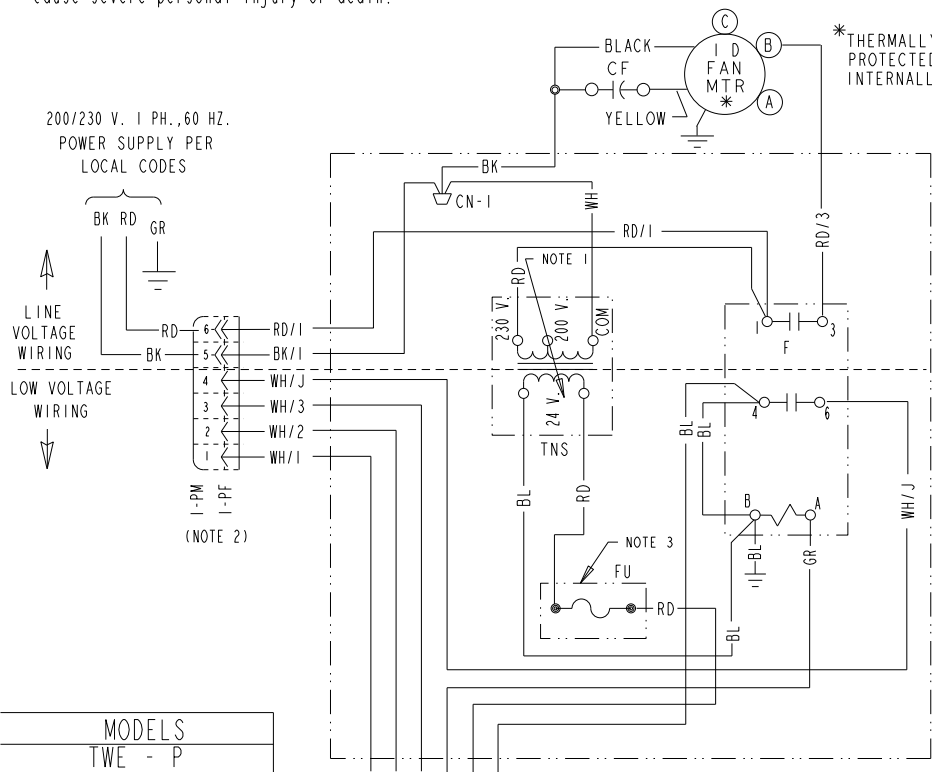

MODELS
TWE - P
2/4TEP-
2/4TEC3F18-36
2TGB3F18-36
TWG018-36

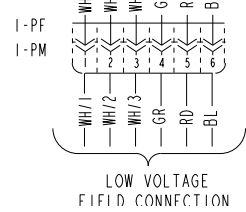

- NOTES:
- FOR 200V OPERATION SWAP RED TRANSFORMER LEAD AND INSULATED CAP ON 200V CENTER TRANSFORMER TERMINAL.
 - WHEN HEATERS ARE USED, DISCARD I-PM WITH ATTACHED LEADS AND CONNECT I-PF TO THE MATING PLUG IN THE HEATER CONTROL BOX.
 - FOR REPLACEMENT FUSE, USE 5.0 AMP AUTOMOTIVE STYLE FOR ALL MODELS

PRINTED FROM C800722P01 REV11

Unit Wiring Diagrams

⚠ WARNING

HAZARDOUS VOLTAGE!
DISCONNECT ALL ELECTRICAL POWER INCLUDING REMOTE DISCONNECTS BEFORE SERVICING.
Failure to disconnect power before servicing can cause severe personal injury or death.

⚠ CAUTION

USE COPPER CONDUCTORS ONLY!
UNIT TERMINALS ARE NOT DESIGNED TO ACCEPT OTHER TYPES OF CONDUCTORS.
Failure to do so may cause damage to the equipment.

AIR FLOW SELECTION	
TERM	SPEED
A	LOW
B	MED
C	HIGH

LEGEND

- 24 V.
- LINE V.
- ⊥ GROUND
- JUNCTION
- ⊢ CAPACITOR
- △ WIRE CONNECTOR
- TERMINAL
- ⎓ TRANSFORMER
- ⎓ FUSE
- ⊢ RELAY CONTACT NO
- ⎓ MAGNETIC COIL

- POL. PLUG FEMALE (MALE TERMINALS)
- POL. PLUG MALE (FEMALE TERMINALS)

- CN WIRE CONNECTOR
- CF FAN CAPACITOR
- F FAN RELAY
- FU FUSE
- PCB PRINTED CIRCUIT BOARD
- PF POLARIZED PLUG (FEMALE HOUSING)
- PM POLARIZED PLUG (MALE HOUSING)
- TNS TRANSFORMER
- ← COLOR OF WIRE
- BK/BL BLACK WIRE WITH BLUE MARKER
- ← COLOR OF MARKER
- BK BLACK RD RED OR ORANGE
- BL BLUE WH WHITE GR GREEN
- BR BROWN YL YELLOW PR PURPLE

200/230 V. 1 PH., 60 HZ.
POWER SUPPLY PER
LOCAL CODES

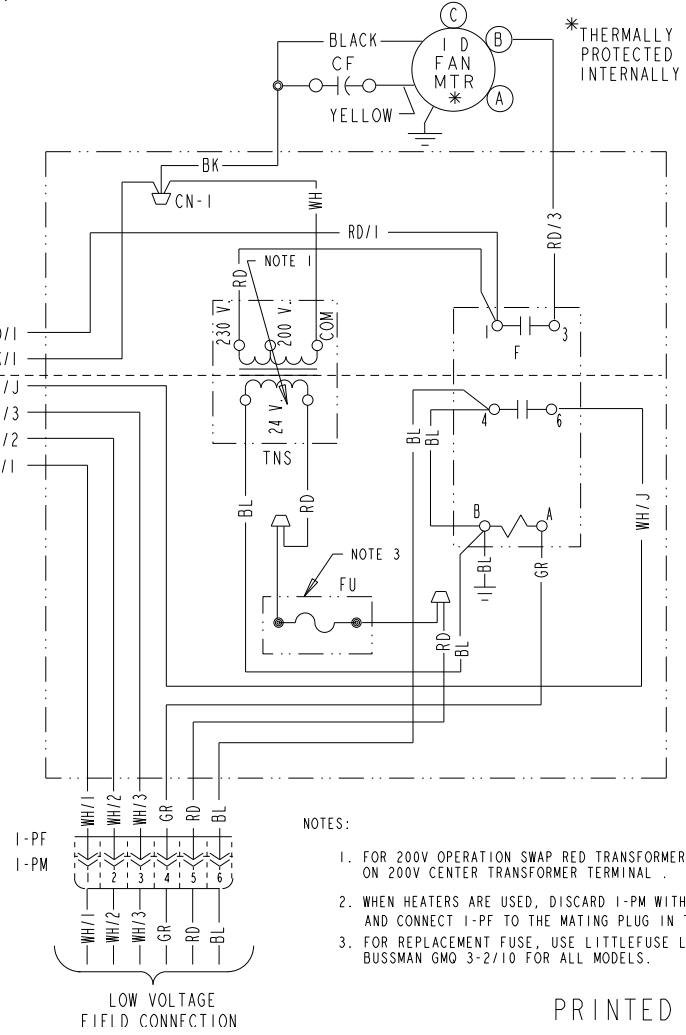
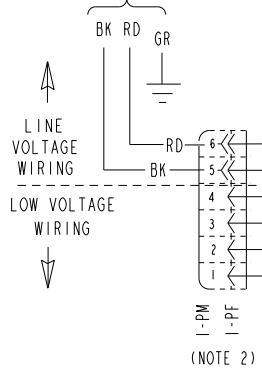

MODELS
2/4TEC3F42-55
TGB42-48
TWG037-060

NOTES:

1. FOR 200V OPERATION SWAP RED TRANSFORMER LEAD AND INSULATED CAP ON 200V CENTER TRANSFORMER TERMINAL .
2. WHEN HEATERS ARE USED, DISCARD 1-PM WITH ATTACHED LEADS AND CONNECT 1-PF TO THE MATING PLUG IN THE HEATER CONTROL BOX.
3. FOR REPLACEMENT FUSE, USE LITTLEFUSE LMF 3-2/10 OR BUSSMAN GQO 3-2/10 FOR ALL MODELS.

PRINTED FROM C801953P01 REV02

OUTLINE DRAWING FOR TWG018,025,030,036A140A

(ALL DIMENSIONS ARE IN INCHES)

MINIMUM UNIT CLEARANCE TABLE		
SIDES	TO COMBUSTIBLE MATERIAL (REQUIRED)	SERVICE CLEARANCE (RECOMMENDED)
FRONT	0"	2"
BACK	0"	2"
INLET DUCT	0"	0"
OUTLET DUCT	1"	1"

* 1" FOR THE FIRST 3 FT. OF OUTLET DUCT WHEN ELECTRIC HEATERS ARE INSTALLED, EXCEPT MODELS BAYHR1405, 1408, AND 1410 ARE APPROVED FOR 0" PLENUM AND DUCT CLEARANCE IN THE UPFLOW CONFIGURATION ONLY.

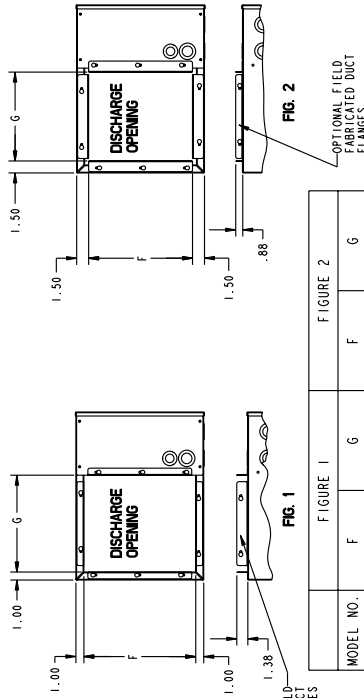
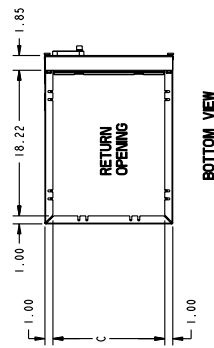
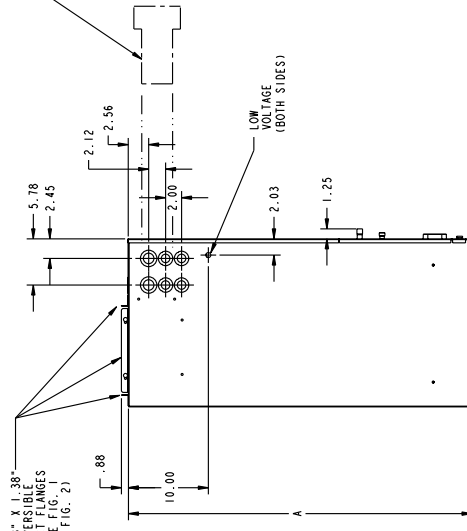
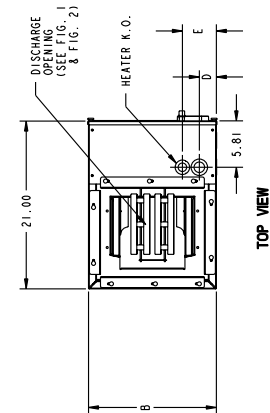

MODEL NO.	FIGURE 1					FIGURE 2				
	F	G	F	G	F	F	G	F	G	F
TWG018A	14.00	12.12	13.00	11.12	13.00	11.12				
TWG025A	16.00	12.12	15.00	11.12	15.00	11.12				
TWG030A	16.00	12.12	15.00	11.12	15.00	11.12				
TWG036A	16.00	12.12	15.00	11.12	15.00	11.12				
2/4TGB-18	16.00	12.12	15.00	11.12	15.00	11.12				
2/4TGB-25	16.00	12.12	15.00	11.12	15.00	11.12				
2/4TGB-30	16.00	12.12	15.00	11.12	15.00	11.12				
2/4TGB-36	16.00	12.12	15.00	11.12	15.00	11.12				

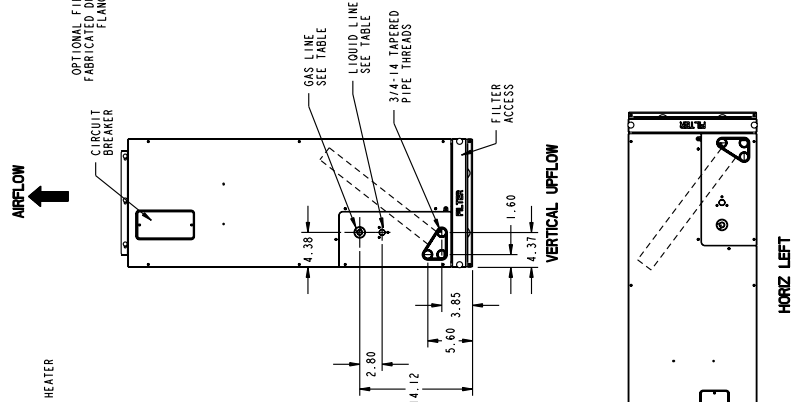

MODEL NO.	A	B	C	D	E	FLOW CONTROL	GAS LINE SIZE	LIQUID LINE SIZE
TWG018A	43.00	16.00	14.00	2.13	4.25	FCCV	5/8 BRAZE	1/4 BRAZE
TWG025A	45.70	18.00	16.00	3.13	5.25	FCCV	3/4 BRAZE	5/16 BRAZE
TWG030A	45.70	18.00	16.00	3.13	5.25	FCCV	3/4 BRAZE	5/16 BRAZE
TWG036A	52.00	18.00	16.00	3.13	5.25	FCCV	7/8 BRAZE	3/8 BRAZE
2TGB-18	45.70	18.00	16.00	3.13	5.25	TXV	5/8 BRAZE	1/4 BRAZE
2TGB-25	45.70	18.00	16.00	3.13	5.25	TXV	5/8 BRAZE	1/4 BRAZE
2TGB-30	52.00	18.00	16.00	3.13	5.25	TXV	3/4 BRAZE	5/16 BRAZE
2TGB-36	52.00	18.00	16.00	3.13	5.25	TXV	7/8 BRAZE	3/8 BRAZE
4TGB-18	45.70	18.00	16.00	3.13	5.25	TXV	1/2 BRAZE	3/8 BRAZE
4TGB-25	45.70	18.00	16.00	3.13	5.25	TXV	5/8 BRAZE	3/8 BRAZE
4TGB-30	52.00	18.00	16.00	3.13	5.25	TXV	3/4 BRAZE	3/8 BRAZE
4TGB-36	52.00	18.00	16.00	3.13	5.25	TXV	3/4 BRAZE	3/8 BRAZE

METRIC CONVERSION
INCHES X 25.4 MM

D810094REV05

OUTLINE DRAWING FOR TWG037, 042, 048, 060A

(ALL DIMENSIONS ARE IN INCHES)

	TO COMBUSTIBLE MATERIAL (REQUIRED)	SERVICE CLEARANCE (RECOMMENDED)
SIDES	0"	2"
FRONT	0"	2"
BACK	0"	0"
INLET DUCT	0"	0"
OUTLET DUCT	F*	F

* 1" FOR THE FIRST 3 FT. OF OUTLET DUCT WHEN ELECTRIC HEATERS ARE INSTALLED. EXCEPT MODELS BAYHRIADOS, 1408, AND 1410 ARE APPLICABLE. FLEETING AND DUCT CLEARANCE IN THE UPFLOW CONFIGURATION ONLY.

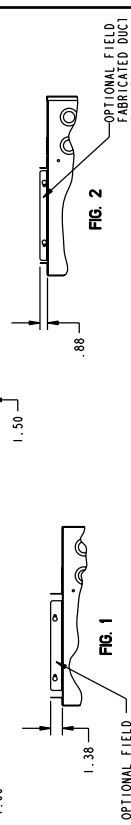
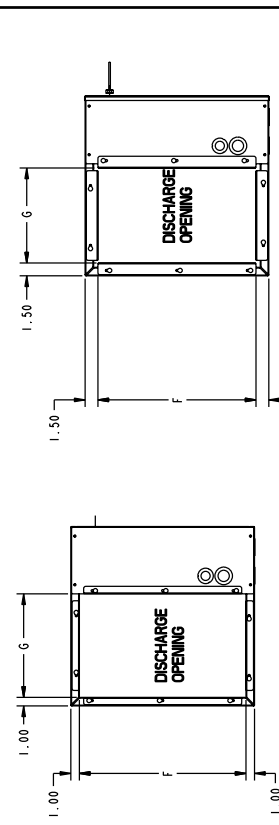
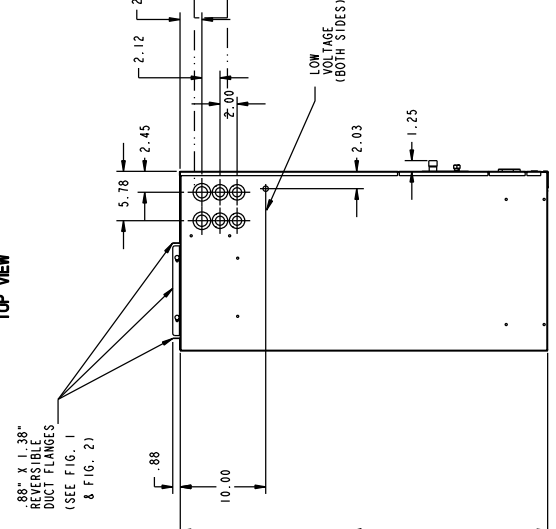
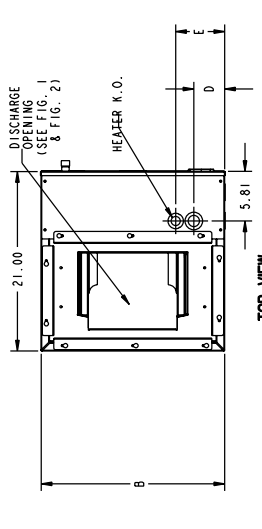

MODEL NO.	FIG. 1		FIG. 2	
	F	G	F	G
TWG037A	19.50	12.12	18.50	11.12
TWG042A, 2/4TGB42	21.50	12.12	20.50	11.12
TWG048A	21.50	12.12	20.50	11.12
TWG060A, 2/4TGB48	21.50	12.12	20.50	11.12

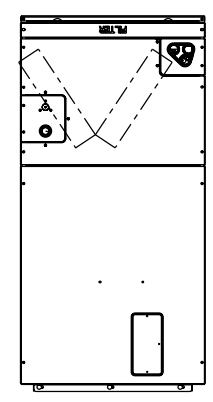

HORIZ LEFT

MODEL NO.	A	B	C	D	E	H	FLOW CONTROL	GAS LINE SIZE	LIQUID LINE SIZE
TWG037A	43.00	21.50	19.50	3.61	5.73	13.50	FCCV	7/8 BRAZE	3/8 BRAZE
TWG042A	43.00	23.50	21.50	4.61	6.73	13.50	FCCV	7/8 BRAZE	3/8 BRAZE
TWG048A	48.25	23.50	21.50	4.61	6.73	18.75	FCCV	7/8 BRAZE	3/8 BRAZE
TWG060A, 2TGB48	57.25	23.50	21.50	4.61	6.73	22.50	TXV	7/8 BRAZE	3/8 BRAZE
2TGB42	48.25	23.50	21.50	4.61	6.73	18.25	TXV	7/8 BRAZE	3/8 BRAZE
4TGB42	48.25	23.50	21.50	4.61	6.73	18.25	TXV	3/4 BRAZE	3/8 BRAZE
4TGB48	57.25	23.50	21.50	4.61	6.73	22.50	TXV	7/8 BRAZE	3/8 BRAZE

METRIC CONVERSION
INCHES X 25.4 MM

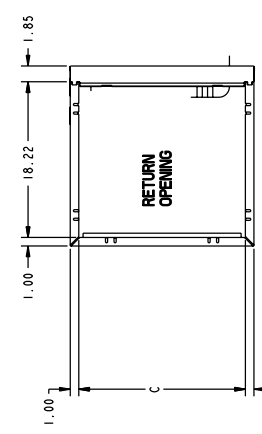

BOTTOM VIEW

D810126REV04

Mechanical Specification Options

Features and General Information

These blower coil units are completely factory assembled including coil, condensate drain pan, fan, motor, filters and controls in an insulated casing that can be applied in horizontal left or vertical upflow configuration. This model has 4.2 "R" value insulation and additional sealing systems.

The unit ships in the left-hand horizontal configuration and converts to vertical upflow just by standing the unit on end. No tools required.

Casing

These models have a rugged galvanized sheet metal and steel frame construction. The casing is painted with an enamel finish. The casing is insulated and provides knockouts for electrical power and control wiring.

Refrigerant Circuits

The TWG units have a single refrigerant circuit. The refrigerant circuit is controlled by a factory installed flow control check valve (FCCV). The TWG060A150A is controlled by a bleed thermal expansion valve (TXVB).

Coil

Aluminum fin surface is mechanically bonded to 3/8 inch OD copper tubing. Coils are factory pressure and leak tested.

Fan

The blower housing is forward curved, dynamically balanced with a speed direct drive fan motor. The fan motor is permanently lubricated.

Controls

Low voltage fan contactor, and plug-in module for accessory electric heat control is included. TWG models also have a check valve.

Filters

The TWG018A through TWG060A have standard size filters.

Electric Heaters

Heaters for the TWG air handlers are available in a wide range of capacities and voltages with various staging options, and plug-in control wiring. Heaters fit inside the internal compartment.



Trane
6200 Troup Highway
Tyler, TX 75707
www.trane.com

For more information contact
your local dealer (distributor).



Since **Trane** has a policy of continuous product and product data improvement, it reserves the right to change design and specifications without notice.