



Product Data

Upflow/ Horizontal Left/Right, Downflow Single and 2-Stage Non-Condensing Gas Fired Furnace

Upflow, Downflow, Horizontal Right/Left

Single Stage

S8X1A026M2PSAB
S8X1A040M3PSAB
S8X1B040M2PSAB
S8X1B060M3PSAB
S8X1B060M4PSAB
S8X1B080M4PSAB
S8X1C080M5PSAB
S8X1C100M5PSAB
S8X1D120M5PSAB

Two Stage

S8X2A040M3PSAB
S8X2B060M3PSAB
S8X2B060M4PSAB
S8X2B080M4PSAB
S8X2C080M5PSAB
S8X2C100M5PSAB
S8X2D120M5PSAB

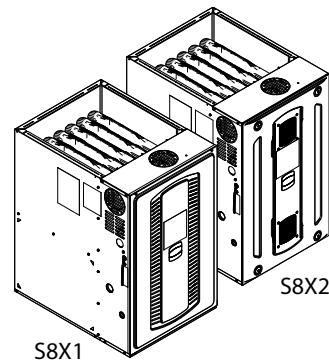

Note: Models may have a "T" in the 12th digit designating they meet California less than 40 ng/J (NOx) emissions requirements.

Note: Graphics in this document are for representation only. Actual model may differ in appearance.



General Features

NATURAL GAS MODELS

Central Heating furnace designs are certified by Intertek for both natural and L.P. gas. Limit setting and rating data were established and approved under standard rating conditions using American National Standards Institute standards.

SAFE OPERATION

The Integrated System Control is a solid state device which continuously monitors for presence of flame when the system is in the heating mode of operation. Dual solenoid combination gas valve and regulator provide additional safety.

QUICK HEATING

Durable, cycle tested, heavy gauge **tubular aluminized steel heat exchanger** quickly transfers heat to provide warm conditioned air to the structure. **Low energy power vent blower**, to increase efficiency and provide a discharge of gas fumes to the outside.

BURNERS

Multiport, Inshot burners will give years of quiet and efficient service. All models can be converted to **L.P. gas** with LP conversion kit.

INTEGRATED SYSTEM CONTROL

Exclusively designed operational program provides total control of furnace limit sensors, blowers, gas valve, flame control and includes self diagnostics for ease of service.

ENERGY EFFICIENT OPERATION

Air-Tite™ cabinet design is certified to <1% air leakage per ASHRAE 193 "Method of Test for Determining the Airtightness of HVAC Equipment."

AIR DELIVERY

The 9 speed constant torque blower motor has sufficient airflow for most heating and cooling requirements and will switch from heating to cooling speeds on demand from room thermostat.

STYLING

Heavy gauge steel and "wrap-around" cabinet construction is used in the cabinet with baked-on enamel finish for strength and beauty. Every orientation has at least two venting options. There are no knockouts on cabinet.

FEATURES AND GENERAL OPERATION

The S-Series furnace utilizes a Silicon Nitride Hot Surface Ignition system, which eliminates the waste of a constant burning pilot. The integrated system control lights the main burners upon a demand for heat from the room thermostat. Complete front service access.

- a. Low energy power venter
- b. Vent proving pressure switches.



Features and Benefits

80% AFUE on S8X1 and S8X2 FURNACE MODELS

Lowers utility bills

ELECTRICALLY EFFICIENT

Efficient airflow design reduces electrical energy use

34 INCH TALL

Lighter, easier to move and fit into tight spaces like short basements or tight closets

Works great with larger, high-efficiency coils

No knockouts

4-WAY MULTI-POISE

S8X1 – 9 SKU's – Upflow / Downflow / Horizontal Left / Horizontal Right

S8X2 – 7 SKU's – Upflow / Downflow / Horizontal Left / Horizontal Right

Added application flexibility and reduction in specification errors

AIRFLOW

At least 400 CFM/ton at 0.5 in. H₂O external static pressure

REGULATORY

All models are air tight; 1% or less air leakage as per ASHRAE 193

Open vestibule design provides a full 34" high open vestibule for ease of installation and service

DIMENSIONS

Widths are industry standard: 14.5", 17.5", 21", and 24.5"

Depth remains approximately 28"

Cabinet is compatible with industry standard coils, as well as, other accessories

INTEGRATED FURNACE CONTROL

Setup / Status / Diagnostics / Digital Display

No dip switches

Last six errors stored

Dry contact EAC and HUM connections

All Molex connections; no spade terminals

Low voltage labeled above and below

Rain shield over IFC keeps condensate off the control

TUBULAR ALUMINIZED STEEL HEAT EXCHANGER

VORTICA II BLOWER, DESIGNED EXCLUSIVELY FOR THE S-SERIES FURNACE

Improved airflow efficiency

Durable, easy to clean, housing

Single piece belly band/ motor arm assembly

Blower deck has full-length rails for easy removal and replacement, regardless of poise

FOUR-WAY MULTI-POISE (UPFLOW, DOWNFLOW, HORIZONTAL LEFT AND RIGHT)

Easier to specify

Shipped ready to install (no conversion kits required)

Every model has at least two venting options



Accessories

Table 1. Accessories

Model Number	Description	Use with
BAYHANG	Horizontal Hanging Kit	All Furnaces
BAYLIFTB	Dual Return Kit (B size extension)	B Cabinet Furnaces
BAYLIFTC	Dual Return Kit (C size extension)	C Cabinet Furnaces
BAYLIFTD	Dual Return Kit (D size extension)	D Cabinet Furnaces
BAYBASE205	Downflow Subbase	All Furnaces in Downflow orientation
BAYSF1165AA ^(a)	1" SlimFit Box with MERV 4 Filter	All Furnaces
BAYSF1255BA	1" SlimFit Filter and Insulated Frame	All furnaces when used in side return application B Cabinet furnaces only when in bottom return application
FLRSF1255	1" Filter replacement (Qty 12)	BAYSF1255BA
BAYVENT600A	Internal venting kit	B, C, and D Furnaces in Downflow orientation
BAYVENT800B	Masonry Chimney Vent Kit	All furnaces
BAYSWT20AHALTAA	High Altitude Pressure Switch Kit	S8X1A026M2P*
BAYSWT21AHALTAA	High Altitude Pressure Switch Kit	S8X1A040M3P*, S8X1B040M2P*
BAYSWT22AHALTAA	High Altitude Pressure Switch Kit	S8X2A040M3P*
BAYSWT14AHALTAB	High Altitude Pressure Switch Kit	S8X1C080M5P*, S8X1C100M5P*, S8X1D120M5P*
BAYSWT15AHALTAA	High Altitude Pressure Switch Kit	S8X1B060M3P*, S8X1B060M4P*, S8X1B080M4P*
BAYSWT16AHALTAB	High Altitude Pressure Switch Kit	S8X2C080M5P*
BAYSWT17AHALTAA	High Altitude Pressure Switch Kit	S8X2B060M3PSAAA, S8X2B060M4PSAAA
BAYSWT18AHALTAA	High Altitude Pressure Switch Kit	S8X2B080M4P*
BAYSWT19AHALTAA	High Altitude Pressure Switch Kit	S8X2C100M5P*
BAYSWT23AHALTAA	High Altitude Pressure Switch Kit	S8X2B060M3PSAAB & later, S8X2B060M3PTAAA & later, S8X2B060M4PSAAB & later, S8X2B060M4PTAAA & later
BAYSWT24AHALTAA	High Altitude Pressure Switch Kit	S8X2D120M5P*
BAYLPSS400*	Propane Conversion Kit with Stainless Steel Burners	All Furnaces except S8X1A026
BAYLPSS410A	Propane Conversion Kit with Stainless Steel Burners	S8X1A026 Furnace only
PIP02095	U fitting for gas piping	All Furnaces for right hand gas entry

^(a) Airflow greater than 1600 CFM requires dual returns



Product Specifications

MODEL	S8X1A026M2PSAB	S8X1A040M3PSAB	S8X1B040M2PSAB
TYPE	Upflow / Horizontal / Downflow	Upflow / Horizontal / Downflow	Upflow / Horizontal / Downflow
RATINGS ^(a)			
Input BTUH	26,000	40,000	40,000
Capacity BTUH (ICS) ^{(b) (c)}	20,700	31,800	32,900
Temp. Rise (Min.-Max.)	25 - 55	30 - 60	30 - 60
AFUE (%)	80	80	80
Return Air Temp. (Min. - Max.)	55°F - 80°F	55°F - 80°F	55°F - 80°F
BLOWER DRIVE	DIRECT	DIRECT	DIRECT
Diameter — Width (In.)	11 X 8	11 X 8	11 X 8
No. Used	1	1	1
Speeds (No.) ^(d)	9	9	9
CFM vs. in. w.g.	See Fan Performance Table	See Fan Performance Table	See Fan Performance Table
Motor HP	1/3	1/2	1/3
RPM	1075	1075	1075
Volts/Ph/Hz	120 / 1 / 60	120 / 1 / 60	120 / 1 / 60
FLA	4.1	6.4	4.1
COMBUSTION FAN — Type	Centrifugal	Centrifugal	Centrifugal
Drive — No. Speeds	Direct - 1	Direct - 1	Direct - 1
Motor HP — RPM	3300	3300	3300
Volts/Ph/Hz	120 / 1 / 60	120 / 1 / 60	120 / 1 / 60
FLA	1.39	1.39	1.39
FILTER — Furnished?	No	No	No
Type recommended	High Velocity	High Velocity	High Velocity
High Vel. (No.-Size-Thk.)	1 — 14x25 — 1 in.	1 — 14x25 — 1 in.	1 — 16x25 — 1 in.
VENT PIPE DIAMETER — Min (in.) ^(e)	4 Round	4 Round	4 Round
HEAT EXCHANGER — Type	Aluminized Steel	Aluminized Steel	Aluminized Steel
Gauge (Fired)	20	20	20
ORIFICES — Main			
Nat. Gas Qty. — Drill Size	2 - 51	2 - 45	2 - 45
GAS VALVE	Redundant - Single Stage	Redundant - Single Stage	Redundant - Single Stage
PILOT SAFETY DEVICE			
Type	120 V SiNi Igniter	120 V SiNi Igniter	120 V SiNi Igniter
BURNERS — QTY	2	2	2
POWER CONN. — V/Ph/Hz ^(f)	120 / 1 / 60	120 / 1 / 60	120 / 1 / 60
Ampacity (Amps)	6.7	9.6	6.7
Max. Overcurrent Protection (Amps)	15	15	15
PIPE CONN. SIZE (in.)	1/2	1/2	1/2
DIMENSIONS			
Uncrated (In.)	34 x 14.5 x 28.75	34 x 14.5 x 28.75	34 x 17.5 x 28.75
Crated (In.)	35.5 x 16.5 x 30.87	35.5 x 16.5 x 30.87	35.5 x 19.5 x 30.87



Product Specifications

MODEL	S8X1A026M2PSAB	S8X1A040M3PSAB	S8X1B040M2PSAB
WEIGHT			
Shipping (Lbs.) / Net (Lbs.)	102 / 94	102 / 94	128 / 120

(a) For U.S. applications, above input ratings (BTUH) are up to 2,000 feet, derate 4% per 1,000 feet for elevations above 2,000 feet above sea level.

(b) Central Furnace heating designs are certified to ANSI Z21.47 / CSA 2.3 — latest edition.

(c) Based on U.S. government standard tests.

(d) 9 Speed constant torque ECM blower motor.

(e) Refer to the Installer's Guide.

(f) The above wiring specifications are in accordance with National Electrical Code; however, installations must comply with local codes.

MODEL	S8X1B060M3PSAB	S8X1B060M4PSAB	S8X1B080M4PSAB
TYPE	Upflow / Horizontal / Downflow	Upflow / Horizontal / Downflow	Upflow / Horizontal / Downflow
RATINGS (a)			
Input BTUH	60,000	60,000	80,000
Capacity BTUH (ICS) (b) (c)	49,300	48,900	65,000
Temp. Rise (Min.-Max.)	30 - 60	30 - 60	30 - 60
AFUE (%) (c)	80	80	80
Return Air Temp. (Min. - Max.)	55°F - 80°F	55°F - 80°F	55°F - 80°F
BLOWER DRIVE	DIRECT	DIRECT	DIRECT
Diameter — Width (In.)	11 X 8	11 X 8	11 X 8
No. Used	1	1	1
Speeds (No.) (d)	9	9	9
CFM vs. in. w.g.	See Fan Performance Table	See Fan Performance Table	See Fan Performance Table
Motor HP	1/2	3/4	3/4
RPM	1075	1075	1075
Volts/Ph/Hz	120 / 1 / 60	120 / 1 / 60	120 / 1 / 60
FLA	6.4	9.2	9.2
COMBUSTION FAN — Type	Centrifugal	Centrifugal	Centrifugal
Drive — No. Speeds	Direct - 1	Direct - 1	Direct - 1
Motor HP — RPM	3300	3300	3300
Volts/Ph/Hz	120 / 1 / 60	120 / 1 / 60	120 / 1 / 60
FLA	1.39	1.39	1.39
FILTER — Furnished?	No	No	No
Type recommended	High Velocity	High Velocity	High Velocity
High Vel. (No.-Size-Thk.)	1 — 16x25 — 1 in.	1 — 16x25 — 1 in.	1 — 16x25 — 1 in.
VENT PIPE DIAMETER — Min (in.) (e)	4 Round	4 Round	4 Round
HEAT EXCHANGER — Type	Aluminized Steel	Aluminized Steel	Aluminized Steel
Gauge (Fired)	20	20	20
ORIFICES — Main			
Nat. Gas Qty. — Drill Size	3 - 45	3 - 45	4 - 45
GAS VALVE	Redundant - Single Stage	Redundant - Single Stage	Redundant - Single Stage
PILOT SAFETY DEVICE			
Type	120 V SiNi Igniter	120 V SiNi Igniter	120 V SiNi Igniter
BURNERS — QTY	3	3	4
POWER CONN. — V/Ph/Hz (f)	120 / 1 / 60	120 / 1 / 60	120 / 1 / 60
Ampacity (Amps)	9.6	13.1	13.1
Max. Overcurrent Protection (Amps)	15	15	15

MODEL	S8X1B060M3PSAB	S8X1B060M4PSAB	S8X1B080M4PSAB
PIPE CONN. SIZE (in.)	1/2	1/2	1/2
DIMENSIONS			
Uncrated (In.)	34 x 17.5 x 28.75	34 x 17.5 x 28.75	34 x 17.5 x 28.75
Crated (In.)	35.5 x 19.5 x 30.87	35.5 x 19.5 x 30.87	35.5 x 19.5 x 30.87
WEIGHT			
Shipping (Lbs.) / Net (Lbs.)	130 / 122	132 / 124	137 / 129

(a) For U.S. applications, above input ratings (BTUH) are up to 2,000 feet, derate 4% per 1,000 feet for elevations above 2,000 feet above sea level.

(b) Central Furnace heating designs are certified to ANSI Z21.47 / CSA 2.3 — latest edition.

(c) Based on U.S. government standard tests.

(d) 9 Speed constant torque ECM blower motor.

(e) Refer to the Installer's Guide.

(f) The above wiring specifications are in accordance with National Electrical Code; however, installations must comply with local codes.

MODEL	S8X1C080M5PSAB	S8X1C100M5PSAB	S8X1D120M5PSAB
TYPE	Upflow / Horizontal / Downflow	Upflow / Horizontal / Downflow	Upflow / Horizontal / Downflow
RATINGS (a)			
Input BTUH	80,000	100,000	120,000
Capacity BTUH (ICS) (b) (c)	65,400	81,800	95,700
Temp. Rise (Min.-Max.)	30 - 60	30 - 60	30 - 60
AFUE (%)	80	80	80
Return Air Temp. (Min. - Max.)	55°F - 80°F	55°F - 80°F	55°F - 80°F
BLOWER DRIVE	DIRECT	DIRECT	DIRECT
Diameter — Width (In.)	11 X 11	11 X 11	11 X 11
No. Used	1	1	1
Speeds (No.) (d)	9	9	9
CFM vs. in. w.g.	See Fan Performance Table	See Fan Performance Table	See Fan Performance Table
Motor HP	1	1	1
RPM	1075	1075	1075
Volts/Ph/Hz	120 / 1 / 60	120 / 1 / 60	120 / 1 / 60
FLA	10.9	10.9	10.9
COMBUSTION FAN — Type	Centrifugal	Centrifugal	Centrifugal
Drive — No. Speeds	Direct - 1	Direct - 1	Direct - 1
Motor HP — RPM	3300	3300	3300
Volts/Ph/Hz	120 / 1 / 60	120 / 1 / 60	120 / 1 / 60
FLA	0.30	0.30	0.34
FILTER — Furnished?	No	No	No
Type recommended	High Velocity	High Velocity	High Velocity
High Vel. (No.-Size-Thk.)	1 — 20x25 — 1 in.	1 — 20x25 — 1 in.	1 — 24x25 — 1 in.
VENT PIPE DIAMETER — Min (in.) (e)	4 Round	4 Round	4 Round
HEAT EXCHANGER — Type	Aluminized Steel	Aluminized Steel	Aluminized Steel
Gauge (Fired)	20	20	20
ORIFICES — Main			
Nat. Gas Qty. — Drill Size	4 - 45	5 - 45	6 - 45
GAS VALVE	Redundant - Single Stage	Redundant - Single Stage	Redundant - Single Stage
PILOT SAFETY DEVICE			
Type	120 V SiNi Igniter	120 V SiNi Igniter	120 V SiNi Igniter



Product Specifications

MODEL	S8X1C080M5PSAB	S8X1C100M5PSAB	S8X1D120M5PSAB
BURNERS — QTY	4	5	6
POWER CONN. — V/Ph/Hz ^(f)	120 / 1 / 60	120 / 1 / 60	120 / 1 / 60
Ampacity (Amps)	14.1	14.1	14.1
Max. Overcurrent Protection (Amps)	15	15	15
PIPE CONN. SIZE (in.)	1/2	1/2	1/2
DIMENSIONS			
Uncrated (In.)	34 x 21 x 28.75	34 x 21 x 28.75	34 x 24.5 x 28.75
Crated (In.)	35.5 x 23 x 30.87	35.5 x 23 x 30.87	35.5 x 26.5 x 30.87
WEIGHT			
Shipping (Lbs.) / Net (Lbs.)	142 / 134	144 / 136	160 / 152

(a) For U.S. applications, above input ratings (BTUH) are up to 2,000 feet, derate 4% per 1,000 feet for elevations above 2,000 feet above sea level.

(b) Central Furnace heating designs are certified to ANSI Z21.47 / CSA 2.3 — latest edition.

(c) Based on U.S. government standard tests.

(d) 9 Speed constant torque ECM blower motor.

(e) Refer to the Installer's Guide.

(f) The above wiring specifications are in accordance with National Electrical Code; however, installations must comply with local codes.

MODEL	S8X2A040M3PSAB	S8X2B060M3PSAB	S8X2B060M4PSAB
TYPE	Upflow / Horizontal / Downflow	Upflow / Horizontal / Downflow	Upflow / Horizontal / Downflow
RATINGS ^(a)			
1st Stage Input BTUH	26,000	39,000	39,000
1st Stage Capacity BTUH (ICS)	20,900	32,000	31,600
2nd Stage Input BTUH	40,000	60,000	60,000
2nd Stage Capacity BTUH (ICS) ^{(b)(c)}	31,800	49,300	48,900
1st Stage Temp. Rise (Min.-Max.)	20 — 50	20 — 50	20 — 50
2nd Stage Temp. Rise (Min.-Max.)	30 — 60	30 — 60	30 — 60
AFUE (%) ^(c)	80	80	80
Return Air Temp. (Min. - Max.)	55°F - 80°F	55°F - 80°F	55°F - 80°F
BLOWER DRIVE	DIRECT	DIRECT	DIRECT
Diameter — Width (In.)	11 X 8	11 X 8	11 X 8
No. Used	1	1	1
Speeds (No.) ^(d)	9	9	9
CFM vs. in. w.g.	See Fan Performance Table	See Fan Performance Table	See Fan Performance Table
Motor HP	1/2	1/2	3/4
RPM	1075	1075	1075
Volts/Ph/Hz	120 / 1 / 60	120 / 1 / 60	120 / 1 / 60
FLA	6.4	6.4	9.2
COMBUSTION FAN — Type	Centrifugal	Centrifugal	Centrifugal
Drive — No. Speeds	Direct - 2	Direct - 2	Direct - 2
Motor HP — RPM	3300 / 2600	3300 / 2600	3300 / 2600
Volts/Ph/Hz	120 / 1 / 60	120 / 1 / 60	120 / 1 / 60
FLA	1.39	0.30	0.30
FILTER — Furnished?	No	No	No
Type recommended	High Velocity	High Velocity	High Velocity
High Vel. (No.-Size-Thk.)	1 — 14x25 — 1 in.	1 — 16x25 — 1 in.	1 — 16x25 — 1 in.
VENT PIPE DIAMETER — Min (in.) ^(e)	4 Round	4 Round	4 Round

Product Specifications

MODEL	S8X2A040M3PSAB	S8X2B060M3PSAB	S8X2B060M4PSAB
HEAT EXCHANGER – Type	Aluminized Steel	Aluminized Steel	Aluminized Steel
Gauge (Fired)	20	20	20
ORIFICES – Main			
Nat. Gas Qty. — Drill Size	2 - 45	3 - 45	3 - 45
GAS VALVE	Redundant - Two Stage	Redundant - Two Stage	Redundant - Two Stage
PILOT SAFETY DEVICE TYPE	120 V SiNi Igniter	120 V SiNi Igniter	120 V SiNi Igniter
BURNERS – Qty	2	3	3
POWER CONN. — V/Ph/Hz ^(f)	120 / 1 / 60	120 / 1 / 60	120 / 1 / 60
Ampacity (Amps)	9.6	8.5	12.0
Max. Overcurrent Protection (Amps)	15	15	15
PIPE CONN. SIZE (in.)	1/2	1/2	1/2
DIMENSIONS			
Uncrated (In.)	34 x 14.5 x 28.75	34 x 17.5 x 28.75	34 x 17.5 x 28.75
Crated (In.)	35.5 x 16.5 x 30.87	35.5 x 19.5 x 30.87	35.5 x 19.5 x 30.87
WEIGHT			
Shipping (Lbs.) / Net (Lbs.)	102 / 94	130 / 122	132 / 124

(a) For U.S. applications, above input ratings (BTUH) are up to 2,000 feet, derate 4% per 1,000 feet for elevations above 2,000 feet above sea level.

(b) Central Furnace heating designs are certified to ANSI Z21.47 / CSA 2.3 — latest edition.

(c) Based on U.S. government standard tests.

(d) 9 Speed constant torque ECM blower motor.

(e) Refer to the Installer's Guide.

(f) The above wiring specifications are in accordance with National Electrical Code; however, installations must comply with local codes.

MODEL	S8X2B080M4PSAB	S8X2C080M5PSAB	S8X2C100M5PSAB	S8X2D120M5PSAB
TYPE	Upflow / Horizontal / Downflow	Upflow / Horizontal / Downflow	Upflow / Horizontal / Downflow	Upflow / Horizontal / Downflow
RATINGS ^(a)				
1st Stage Input BTUH	52,000	52,000	65,000	84,000
1st Stage Capacity BTUH (ICS)	42,400	42,100	52,900	64,900
2nd Stage Input BTUH	80,000	80,000	100,000	120,000
2nd Stage Capacity BTUH (ICS) ^{(b)(c)}	65,000	65,400	81,800	95,700
1st Stage Temp. Rise (Min.-Max.)	30 – 60	30 – 60	30 – 60	25 – 55
2nd Stage Temp. Rise (Min.-Max.)	30 – 60	30 – 60	30 – 60	30 – 60
AFUE (%) ^(c)	80	80	80	80
Return Air Temp. (Min. - Max.)	55°F - 80°F	55°F - 80°F	55°F - 80°F	55°F - 80°F
BLOWER DRIVE	DIRECT	DIRECT	DIRECT	DIRECT
Diameter — Width (In.)	11 X 8	11 X 11	11 X 11	11 X 11
No. Used	1	1	1	1
Speeds (No.) ^(d)	9	9	9	9
CFM vs. in. w.g.	See Fan Performance Table	See Fan Performance Table	See Fan Performance Table	See Fan Performance Table
Motor HP	3/4	1	1	1
RPM	1075	1075	1075	1075
Volts/Ph/Hz	120 / 1 / 60	120 / 1 / 60	120 / 1 / 60	120 / 1 / 60
FLA	9.2	10.9	10.9	10.9
COMBUSTION FAN — Type	Centrifugal	Centrifugal	Centrifugal	Centrifugal
Drive — No. Speeds	Direct - 2	Direct - 2	Direct - 2	Direct - 2
Motor HP — RPM	3300 / 2600	3300 / 2600	3300 / 2600	3300 / 2600



Product Specifications

MODEL	S8X2B080M4PSAB	S8X2C080M5PSAB	S8X2C100M5PSAB	S8X2D120M5PSAB
Volts/Ph/Hz	120 / 1 / 60	120 / 1 / 60	120 / 1 / 60	120 / 1 / 60
FLA	0.30	0.30	0.30	0.34
FILTER — Furnished?	No	No	No	No
Type recommended	High Velocity	High Velocity	High Velocity	High Velocity
High Vel. (No.-Size-Thk.)	1 — 16x25 — 1 in.	1 — 16x25 — 1 in.	1 — 20x25 — 1 in.	1 — 24x25 — 1 in.
VENT PIPE DIAMETER — Min (in.) (e)	4 Round	4 Round	4 Round	4 Round
HEAT EXCHANGER — Type	Aluminized Steel	Aluminized Steel	Aluminized Steel	Aluminized Steel
Gauge (Fired)	20	20	20	20
ORIFICES — Main				
Nat. Gas Qty. — Drill Size	4 - 45	4 - 45	5 - 45	6 - 45
GAS VALVE	Redundant - Two Stage	Redundant - Two Stage	Redundant - Two Stage	Redundant - Two Stage
PILOT SAFETY DEVICE TYPE	120 V SiNi Igniter	120 V SiNi Igniter	120 V SiNi Igniter	120 V SiNi Igniter
BURNERS — (QTY)	4	4	5	6
POWER CONN. — V/Ph/Hz (f)	120 / 1 / 60	120 / 1 / 60	120 / 1 / 60	120 / 1 / 60
Ampacity (Amps)	12.0	14.1	14.1	14.1
Max. Overcurrent Protection (Amps)	15	15	15	15
PIPE CONN. SIZE (in.)	1/2	1/2	1/2	1/2
DIMENSIONS				
Uncrated (In.)	34 x 17.5 x 28.75	34 x 21 x 28.75	34 x 21 x 28.75	34 x 24.5 x 28.75
Crated (In.)	35.5 x 19.5 x 30.87	35.5 x 23 x 30.87	35.5 x 23 x 30.87	35.5 x 26.5 x 30.87
WEIGHT				
Shipping (Lbs.) / Net (Lbs.)	137 / 129	142 / 134	144 / 136	160 / 152

(a) For U.S. applications, above input ratings (BTUH) are up to 2,000 feet, derate 4% per 1,000 feet for elevations above 2,000 feet above sea level.

(b) Central Furnace heating designs are certified to ANSI Z21.47 / CSA 2.3 — latest edition.

(c) Based on U.S. government standard tests.

(d) 9 Speed constant torque ECM blower motor.

(e) Refer to the Installer's Guide.

(f) The above wiring specifications are in accordance with National Electrical Code; however, installations must comply with local codes.



Airflow tables

Furnace Airflow (CFM) Vs. External Static Pressure (in. W.C.)						
Model	Tap	0.1	0.3	0.5	0.7	0.9
S8X1A026M2PSAB	1	559	36	—	—	—
	2	646	266	—	—	—
	3	687	369	50	—	—
	4	755	466	177	—	—
	5	971	755	539	323	106
	6	1024	843	662	481	299
	7	1057	908	758	609	460
	8	1139	999	859	719	579
	9	1275	1152	1028	904	781

Furnace Airflow (CFM) Vs. External Static Pressure (in. W.C.)						
Model	Tap	0.1	0.3	0.5	0.7	0.9
S8X1A040M3PSAB S8X2A040M3PSAB	1	580	34	—	—	—
	2	716	471	226	—	—
	3	743	533	323	113	—
	4	929	742	556	370	183
	5	988	831	675	518	361
	6	1112	975	839	702	566
	7	1174	1046	917	788	659
	8	1280	1164	1049	933	817
	9	1558	1475	1392	1309	1226

Furnace Airflow (CFM) Vs. External Static Pressure (in. W.C.)						
Model	Tap	0.1	0.3	0.5	0.7	0.9
S8X1B040M2PSAB	1	582	—	—	—	—
	2	815	546	277	8	—
	3	872	639	406	172	—
	4	1001	809	617	424	232
	5	1022	838	654	470	286
	6	1075	917	759	601	442
	7	1132	988	844	700	557
	8	1186	1055	925	795	664
	9	1325	1211	1097	983	869

Airflow tables

Furnace Airflow (CFM) Vs. External Static Pressure (in. W.C.)						
Model	Tap	0.1	0.3	0.5	0.7	0.9
S8X1B060M3PSAB S8X2B060M3PSAB	1	629	67	—	—	—
	2	987	795	603	411	219
	3	1184	1042	901	759	618
	4	1244	1109	973	837	701
	5	1366	1244	1123	1001	880
	6	1398	1283	1168	1053	938
	7	1479	1374	1270	1165	1061
	8	1547	1447	1348	1248	1148
	9	1634	1541	1449	1357	1264

Furnace Airflow (CFM) Vs. External Static Pressure (in. W.C.)						
Model	Tap	0.1	0.3	0.5	0.7	0.9
S8X1B060M4PSAB S8X2B060M4PSAB	1	707	225	—	—	—
	2	870	617	363	110	—
	3	1073	895	716	538	360
	4	1264	1126	988	850	713
	5	1384	1260	1137	1013	890
	6	1422	1304	1186	1069	951
	7	1555	1452	1348	1244	1141
	8	1658	1559	1460	1361	1262
	9	2047	1971	1895	1818	1743

Furnace Airflow (CFM) Vs. External Static Pressure (in. W.C.)						
Model	Tap	0.1	0.3	0.5	0.7	0.9
S8X1B080M4PSAB S8X2B080M4PSAB	1	633	297	—	—	—
	2	957	800	719	428	213
	3	1220	1080	940	800	660
	4	1403	1298	1192	1087	981
	5	1524	1428	1336	1248	1164
	6	1684	1574	1544	1401	1337
	7	1700	1625	1551	1476	1401
	8	1858	1790	1723	1656	1589
	9	1967	1898	1829	1760	1691

Furnace Airflow (CFM) Vs. External Static Pressure (in. W.C.)						
Model	Tap	0.1	0.3	0.5	0.7	0.9
S8X1C080M5PSAB S8X2C080M5PSAB	1	908	346	—	—	—
	2	964	583	202	—	—
	3	1518	1323	1129	934	740
	4	1638	1455	1271	1087	904
	5	1798	1636	1475	1313	1152
	6	1911	1761	1611	1461	1310
	7	1993	1850	1708	1565	1423
	8	2214	2091	1969	1846	1723
	9	2652	2551	2450	2348	2247

Furnace Airflow (CFM) Vs. External Static Pressure (in. W.C.)						
Model	Tap	0.1	0.3	0.5	0.7	0.9
S8X1C100M5PSAB S8X2C100M5PSAB	1	918	438	—	—	—
	2	1183	950	716	483	249
	3	1709	1546	1383	1220	1057
	4	1771	1676	1581	1486	1391
	5	1931	1793	1656	1518	1380
	6	2028	1898	1768	1638	1508
	7	2177	2057	1938	1818	1699
	8	2351	2246	2141	2036	1931
	9	2609	2522	2434	2347	2260

Furnace Airflow (CFM) Vs. External Static Pressure (in. W.C.)						
Model	Tap	0.1	0.3	0.5	0.7	0.9
S8X1D120M5PSAB S8X2D120M5PSAB	1	857	416	—	—	—
	2	1282	1043	804	565	326
	3	1596	1426	1255	1085	915
	4	1946	1810	1673	1537	1400
	5	2094	1970	1845	1721	1596
	6	2212	2096	1980	1864	1748
	7	2359	2249	2140	2030	1921
	8	2508	2405	2302	2199	2096
	9	2639	2542	2444	2346	2249



CFM Versus Temperature Rise

S8X1 Furnaces have one stage heating

S8X2 Furnaces have two stage heating. First Stage is Low heating and Second Stage is High heating.

Table 2. S8X1

Model	CFM Versus Temperature Rise																				
	400	500	600	700	800	900	1000	1100	1200	1300	1400	1500	1600	1700	1800	1900	2000	2100	2200	2300	2400
S8X1A026M2PSAB	48	39	32																		
S8X1A040M3PSAB		59	49	42	37	33	30	27													
S8X1B040M2PSAB		59	49	42	37	33	30	27													
S8X1B060M3PSAB					56	49	44	40	37	34	32										
S8X1B060M4PSAB					56	49	44	40	37	34	32										
S8X1B080M4PSAB							59	54	49	46	42	40	37	35	33						
S8X1C080M4PSAB							59	54	49	46	42	40	37	35	33						
S8X1C100M5PSAB										57	53	49	46	44	41	39	37	35	34	32	31
S8X1D120M5PSAB												59	56	52	49	47	44	42	40	39	37

Table 3. S8X2 – Low Heat

Model	CFM Versus Temperature Rise – First Stage (Low) Heating																				
	400	500	600	700	800	900	1000	1100	1200	1300	1400	1500	1600	1700	1800	1900	2000	2100	2200	2300	2400
S8X2A040M3PSAB	48	39	32	28																	
S8X2B060M3PSAB		56	47	40	35	31	28														
S8X2B060M4PSAB		56	47	40	35	31	28														
S8X2B080M4PSAB				55	48	43	39	35	32	30	28										
S8X2C080M5PSAB				55	48	43	39	35	32	30	28										
S8X2C100M5PSAB					60	53	48	44	40	37	34	32	30								
S8X2D120M5PSAB									57	52	48	44	41	39	37	35	33	31			

Table 4. S8X2 – High Heat

Model	CFM Versus Temperature Rise – Second Stage (High) Heating																				
	400	500	600	700	800	900	1000	1100	1200	1300	1400	1500	1600	1700	1800	1900	2000	2100	2200	2300	2400
S8X2A040M3PSAB		59	49	42	37	33	30	27													
S8X2B060M3PSAB					56	49	44	40	37	34	32										
S8X2B060M4PSAB					56	49	44	40	37	34	32										
S8X2B080M4PSAB							59	54	49	46	42	40	37	35	33						
S8X2C080M4PSAB							59	54	49	46	42	40	37	35	33						
S8X2C100M5PSAB										57	53	49	46	44	41	39	37	35	34	32	31
S8X2D120M5PSAB												59	56	52	49	47	44	42	40	39	37

Wiring Diagrams

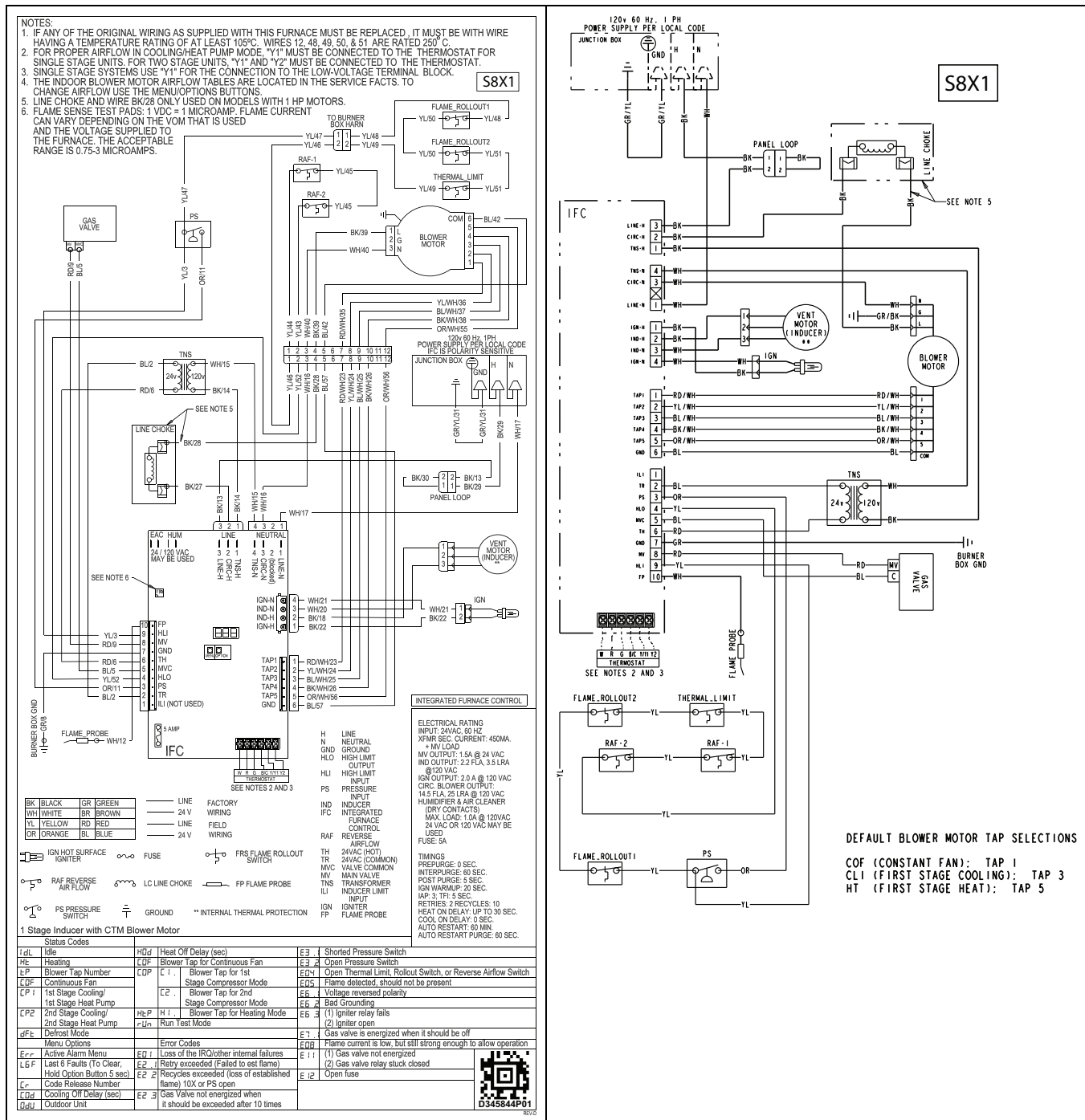



Wiring Diagrams

NOTES:

- IF ANY OF THE ORIGINAL WIRING AS SUPPLIED WITH THIS FURNACE MUST BE REPLACED, IT MUST BE WITH WIRE HAVING A TEMPERATURE RATING OF AT LEAST 105°C. WIRES 12, 48, 50, & 51 ARE RATED 250°C.
- FOR PROPER AIRFLOW IN COOLING/HEAT PUMP MODE, "Y1" MUST BE CONNECTED TO THE THERMOSTAT FOR SINGLE STAGE UNITS. FOR TWO STAGE UNITS "Y1" AND "Y2" MUST BE CONNECTED TO THE THERMOSTAT.
- FOR SINGLE STAGE THERMOSTATS, JUMPER "W1" AND "W2" TERMINALS MUST BE CONNECTED TO THE THERMOSTAT ONCE THE INTER-STAGE DELAY HAS EXPIRED. "HTZ" WILL BE SHOWN ON SEVEN SEGMENT DISPLAY AT ALL TIMES.
- FOR HEAT PUMP SYSTEMS, "Y1" AND "Y2" TERMINALS MUST BE CONNECTED TO THE ROOM THERMOSTAT. FOR TWO STAGE UNITS, "Y1", "Y2", AND "Y3" TERMINALS MUST ALL BE CONNECTED TO THE ROOM THERMOSTAT.
- FOR TWO STAGE SYSTEMS, USE "Y1" FOR LOW SPEED AND "Y2" FOR HIGH SPEED CONNECTION TO THE LOW-VOLTAGE TERMINAL BLOCK.
- USE "Y1" FOR THE CONNECTION TO THE LOW-VOLTAGE TERMINAL BLOCK.
- THE INDOOR BLOWER MOTOR AIRFLOW TABLES ARE LOCATED IN THE SERVICE FACTS. TO CHANGE AIRFLOW USE THE MENU/OPTIONS BUTTONS.
- LINE CHOKE AND WIRE BK/28 ONLY USED ON MODELS WITH 1HP MOTORS.
- FLAME SENSE TEST PADS:
1 VDC = 1 MICROAMP FLAME CURRENT CAN VARY DEPENDING ON THE VOM THAT IS USED AND THE VOLTAGE SUPPLIED TO THE FURNACE. THE ACCEPTABLE RANGE IS 0.75-3 MICROAMPS.

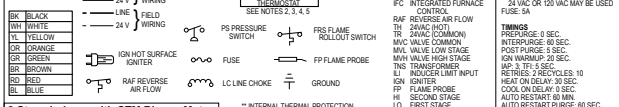
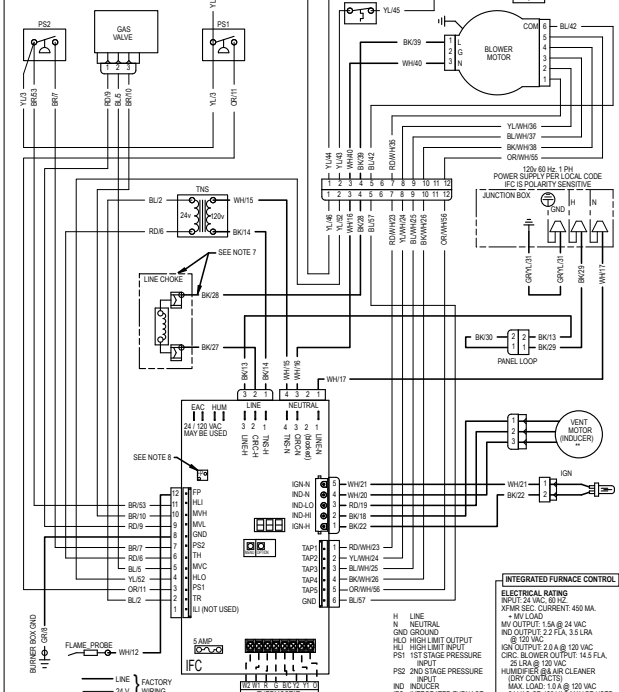

2 Stage Inducer with CTM Blower Motor	
1 Idle	1 Inter-Stage Delay (sec)
1 1st Stage Heating	1 Blower Tap for Continuous Fan
2 2nd Stage Heating	1 Blower Tap for 1st Stage Compressor Mode
3 Blower Tap Number	2 Blower Tap for 2nd Stage Compressor Mode
4 1st Stage Cooling	1 Blower Tap for 1st Stage Heating
5 2nd Stage Cooling	2 Blower Tap for 2nd Stage Heating
6 1st Stage Heat Pump	1 Run Test Mode
7 2nd Stage Heat Pump	1 Error Codes
8 Indirect Mode	1 Loss of the IFC/other internal failures
9 Menu Options	1 Retry exceeded (Failed to est flame)
10 Active Alarm Menu	2 Recycles exceeded (loss of established flame) or 10X PS1 open
11 Last 6 Faults (to Clear Hold Option Button 5 sec)	3 1st Stage Gas Valve not energized when it should be exceeded after 10 times
12 Code Release Number	3 Shorted Pressure Switch, 1st Stage
13 Cooling Off Delay (sec)	3 Shorted Pressure Switch, 2nd Stage
14 Outdoor Limit	3 Open Pressure Switch, 1st Stage
15 Heat Off Delay (sec)	3 Shorted Pressure Switch, 2nd Stage
16 Error Codes	4 Open Pressure Switch, 2nd Stage
17 Error Codes	4 Open Thermal Limit, Rollout Switch, or Reverse Airflow Switch
18 Error Codes	4 Flame detected, should not be present
19 Error Codes	4 Voltage reversed polarity
20 Error Codes	4 Bad Grounding
21 Error Codes	4 Igniter relay fails
22 Error Codes	4 Flame current is low, but still strong enough to allow operation.
23 Error Codes	4 Open Inducer Limit Switch or Condensate Switch
24 Error Codes	4 Igniter open
25 Error Codes	4 1st stage gas valve not energized when it should be
26 Error Codes	4 2nd stage gas valve relay stuck closed
27 Error Codes	4 1st stage gas valve relay stuck closed
28 Error Codes	4 2nd stage gas valve energized when it should not be
29 Error Codes	4 2nd stage gas valve not energized when it should be
30 Error Codes	4 Open fuse

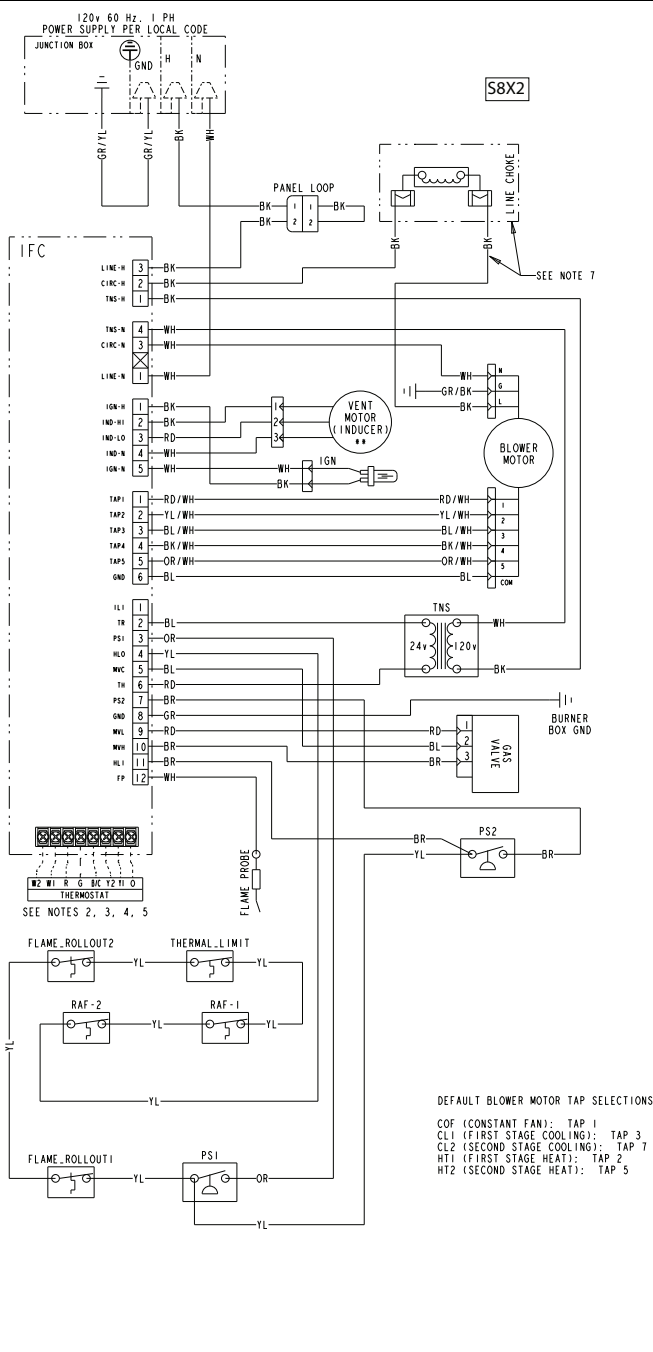

ELECTRICAL RATING	
INFL: 24 VAC, 60 HZ	MAX LOAD: 1.5A @ 24 VAC
XPWR SEC. CURRENT: 450 MA	MAX. LOAD: 1.0A @ 120 VAC
MAX. LOAD: 1.5A @ 24 VAC	24 VAC OR 120 VAC MAY BE USED
IND OUTPUT: 2.27 VA, 3.5 LRA	FUSE: 5A
CRIC: 20 VA, 30 WAC	
CRIC: BLOWER OUTPUT: 14.5 FLA	
24 VAC @ 60 HZ	
HUMIDIFIER 68 AIR CLEANER	
MAX. LOAD: 1.0A @ 120 VAC	
24 VAC OR 120 VAC MAY BE USED	
FUSE: 5A	

TIMINGS	
PRESSURE: 8 SEC	INTERPURGE: 65 SEC
POST PURGE: 5 SEC	IGN WARMUP: 22 SEC
IGN: 3.75 SEC	HEAT ON DELAY: 30 SEC
RETRIEVE: 2 RECYCLES: 10	COOL ON DELAY: 0 SEC
AUTO RESTART PURGE: 60 SEC	



Electrical Connections

Make wiring connections to the unit as indicated on enclosed wiring diagram. As with all gas appliances using electrical power, this furnace shall be connected into a permanently live electric circuit. It is recommended that furnace be provided with a separate "circuit protection device" electric circuit. The furnace must be electrically grounded in accordance with local codes or in the absence of local codes with the National Electrical Code, ANSI/NFPA 70, if an external electrical source is utilized. **The integrated furnace control is polarity sensitive.** The hot leg of the 120V power supply must be connected to the black power lead as indicated on the wiring diagram. Refer to the SERVICE FACTS literature and unit wiring diagram attached to furnace.

Field Wiring

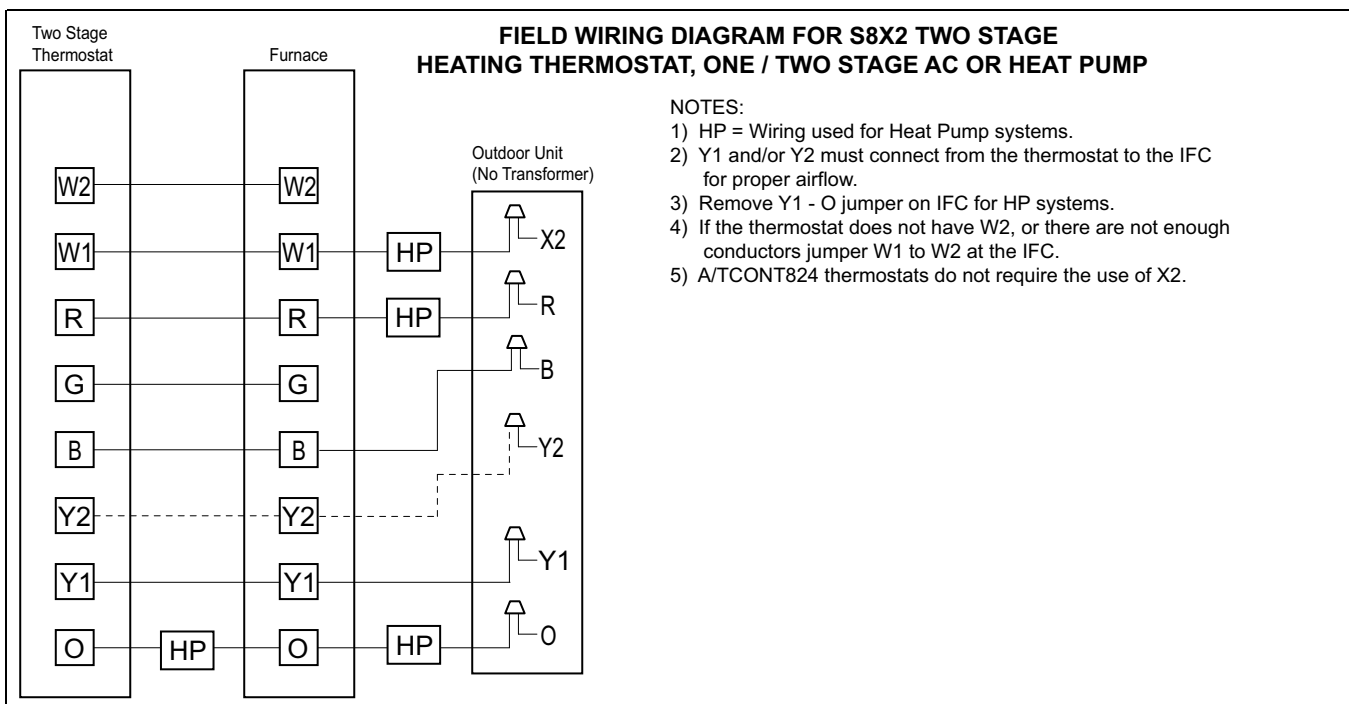
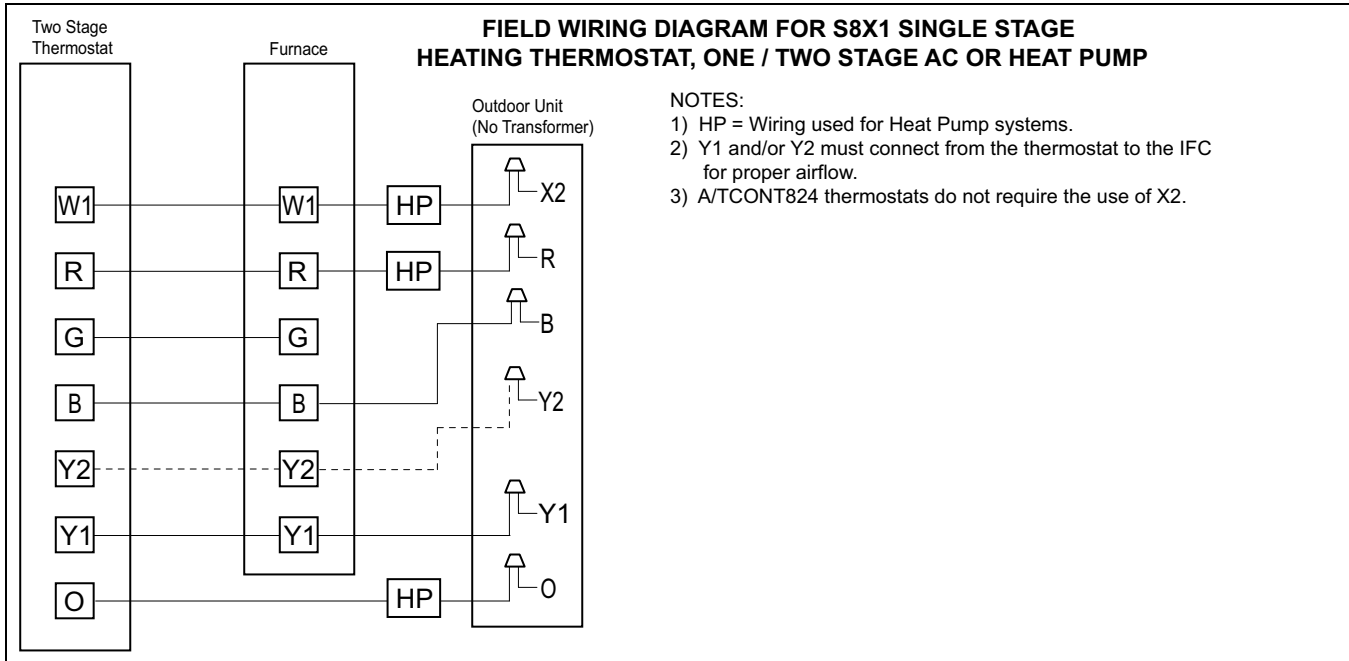

Outline Drawings

Table 5. 14.5" Width Cabinet

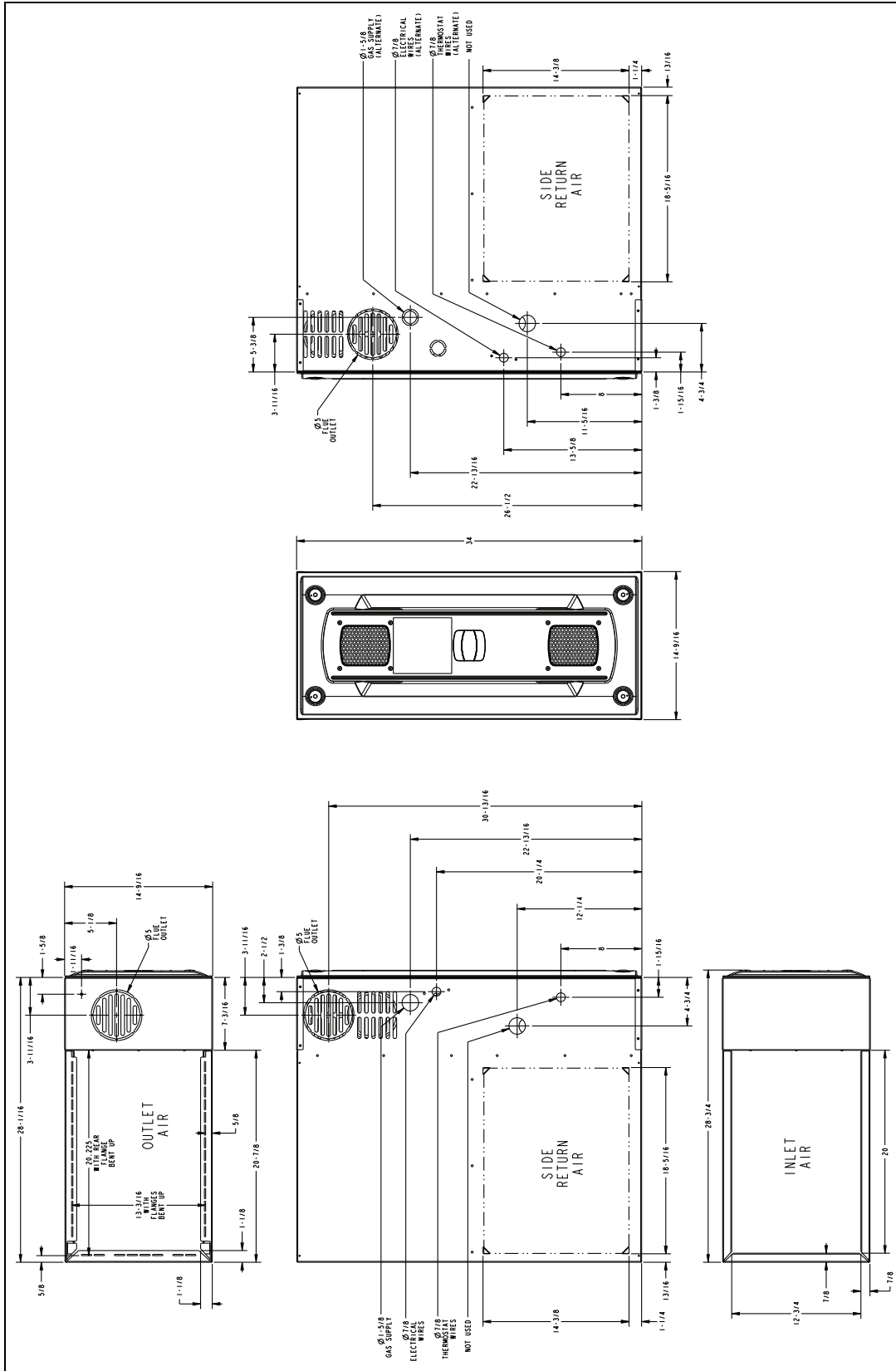
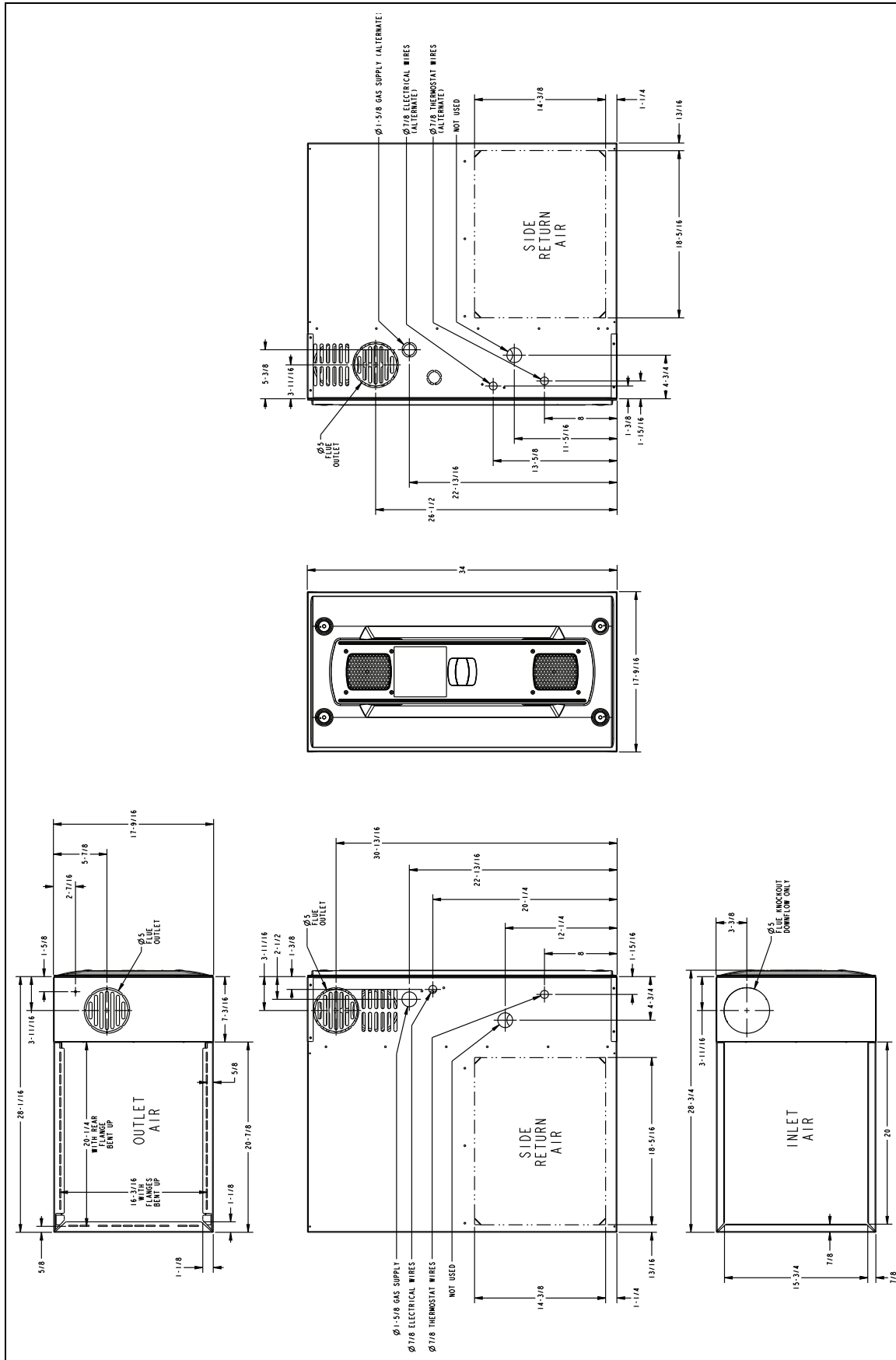

Table 6. 17.5" Width Cabinet





Outline Drawings

Table 7. 21.0" Width Cabinet

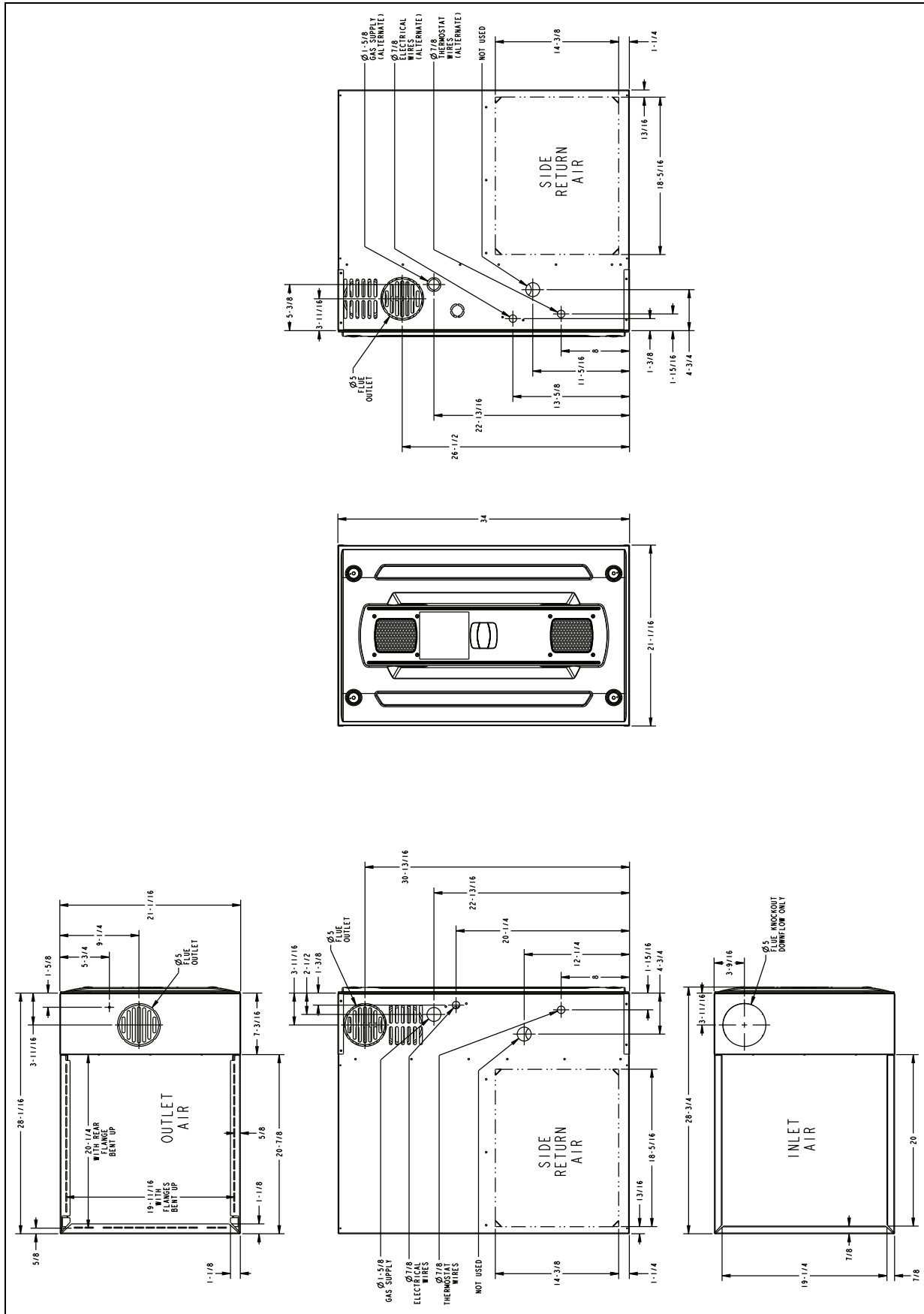
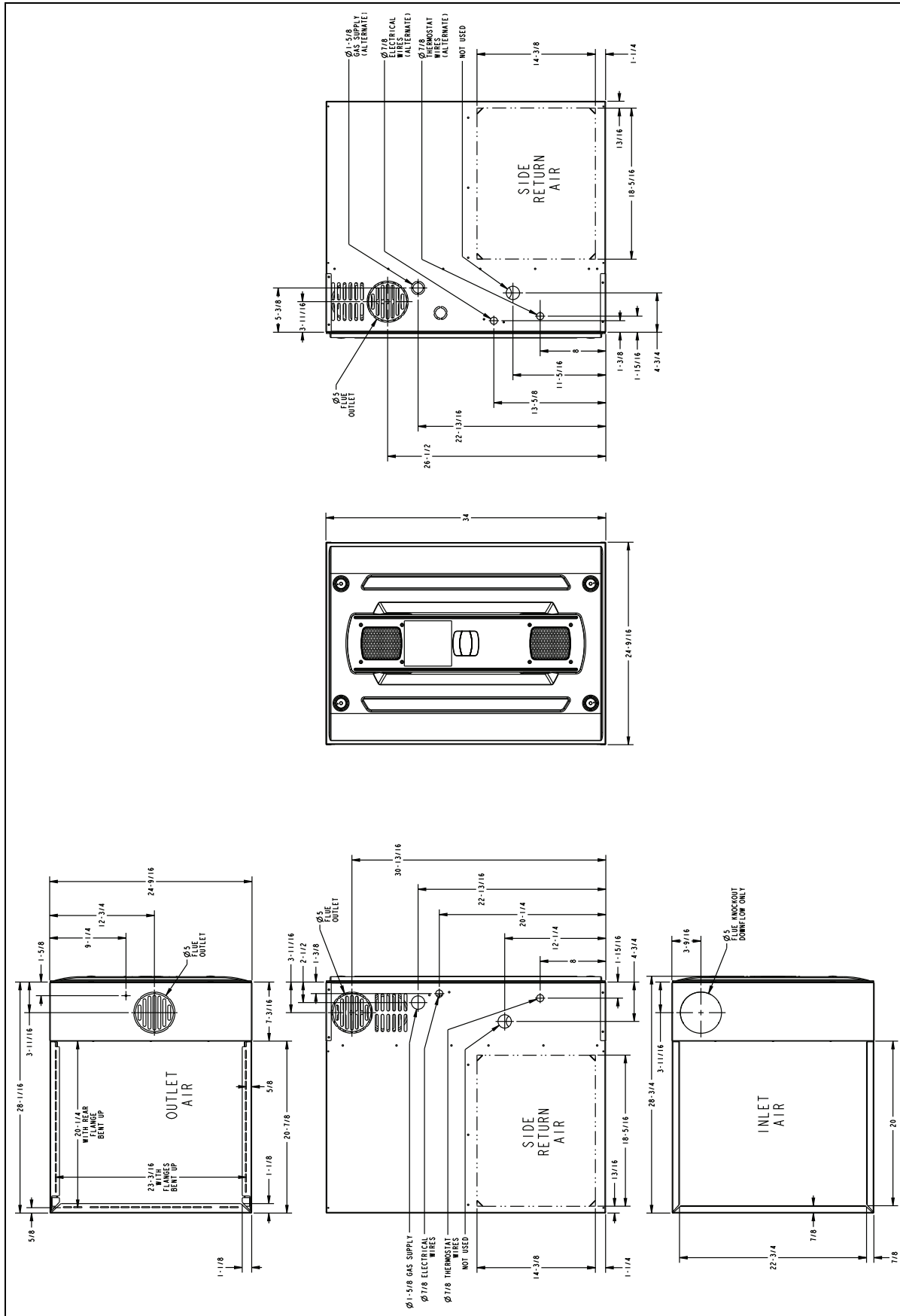

Table 8. 24.5" Width Cabinet





Trane - by Trane Technologies (NYSE: TT), a global innovator - creates comfortable, energy efficient indoor environments for commercial and residential applications. For more information, please visit trane.com or tranetechnologies.com.



Trane has a policy of continuous data improvement and it reserves the right to change design and specifications without notice. We are committed to using environmentally conscious print practices.