

Packaged Heat Pump Units

Horizontal Over/Under Models
WCH024-042C,048-060F

2, 2½, 3, 3½,4, 5 Ton

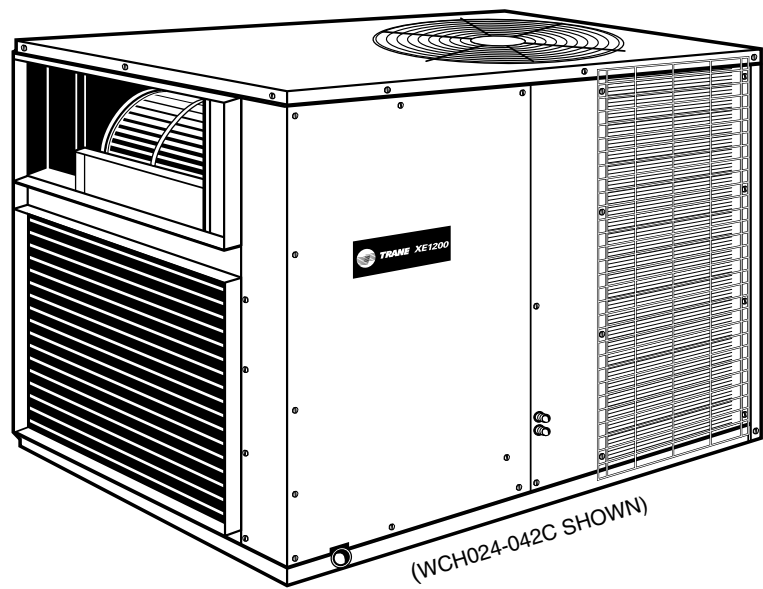



General Features

It's Hard To Stop A Trane.[®]

Horizontal Packaged Heat Pumps

Trane's 2-5 ton packaged heat pumps are designed for efficiency, reliability and easy installation. Although our cooling efficiencies are among the highest in the industry, it is during heating operation that the major benefits of a heat pump materialize. Depending on the outdoor temperature, the Trane heat pump will produce up to 2 to 3 times more heat per unit of power consumed than resistance heating units.

Reliable electronic Demand Defrost, rugged compressor with crank case heater (as required), filter drier and thermal expansion devices are the backbone of Trane heat pump. We have also made installation easier and less costly by standardizing the cabinet and accessories. Two standardized cabinet designs (one cabinet design for the 2-3-1/2 ton models and one cabinet design for the 4-5 ton models).

The Best Heat Pump in the Industry Just Got Better

Better Installability

These heat pump units have an over/under horizontal configuration which provides an efficient airflow delivery. This dedicated design eliminates the need for any unit conversion, saving field labor and installed cost.

Better Serviceability

Accessibility, already a standard feature in Trane heat pump units, has been greatly enhanced. With standardized cabinet designs, all components were designed to be located in the same location, regardless of unit size. Our timesaving rotolock compressor fittings provide easy removal if service on the compressor is required.

A redesigned and simplified control panel that features colored and numbered wire is standard on all products. This aids in reducing troubleshooting time when wire tracing is required. And easy access to all major components

can be accomplished by removing quick service access panels.

Unmatched Quality and Reliability

All major components on these products, including the compressor, have been designed and manufactured for maximum service. Every Climatuff[®] compressor is designed and manufactured to exacting specifications. Each design is life tested in extreme environments to ensure reliable and long lasting operation in normal applications. Each compressor has internal motor protection and crankcase heat for added reliability.

Features and Benefits

The WCH024-042C , 048-060F packaged heat pumps feature:

Design Features

- Climatuff[®] compressor, designed and manufactured to provide reliable, economical operation
- Internal pressure relief and internal overload protection
- Multi-speed indoor fan motor on WCH024-036C models, and variable speed Direct Drive blower motor on WCH042C, 048-060F models.

- External pressure taps for refrigerant check
- Thermal expansion valve refrigerant control
- Demand defrost control system
- Reliable, solenoid-operated reversing valve
- Copper tube, aluminum plate fin coils
- Polarized plug for easy field connection of low voltage to supplementary heater

- Low ambient cooling to 45° F. as manufactured; to 0° F. with accessory
- Duct flanges
- UL and ARI certified
- Outdoor coil guard

Accessories

- Supplemental Electric Heater
- Thermostats
- Low ambient cooling to 0° F.

Contents

General Features	2
Features and Benefits	2
Optional Equipment	4
Selection Procedure	4
Model Number Nomenclature	4
General Data	5
WCH024C100A	5
WCH030C100A	5
WCH036C100B	5
WCH042C100A	5
WCH048F100A	7
WCH060F100A	7
Performance Data	8
Cooling	8
Heating	10
Fan Performance Data	12
Electric Heater Data	14
Field Installed Control Options	14
Hook Up Diagram	15
Typical Wiring	16
Dimensions	17
Mechanical Specifications/Options	19



Features and Benefits

Optional Equipment

OPTIONAL EQUIPMENT FOR PACKAGE UNITS. (Check mark [✓] indicates accessories included.)

Evaporator Defrost Control (Low Ambient Cooling) Kit		BAYLOAM011A []
Anti-short Cycle Timer ^①		BAYASCT001 []
Outdoor Thermostat Kit		BAYSTAT033A []
Supplementary Heaters —	4.33/5.76 KW Heater WCH024-042C1, 048-060F1 (208/240v)	BAYHTRC106A []
	6.12/8.16 KW Heater WCH036-042C1, 048-060F1 (208/240v)	BAYHTRC109A []
	7.93/10.56 KW Heater WCH048F1 ONLY (208/240v)	BAYHTRC110A []
	7.93/10.56 KW Heater WCH024-42C1, 060F1 (208/240v)	BAYHTRC111A []
	12.98/17.28 KW Heater WCH030-042C1, 048-060F1 (208/240v) ^②	BAYHTRC117A []

NOTES:
^① Do not use with programmable thermostats.
^② This model has a fuse box factory provided.

Selection Procedure

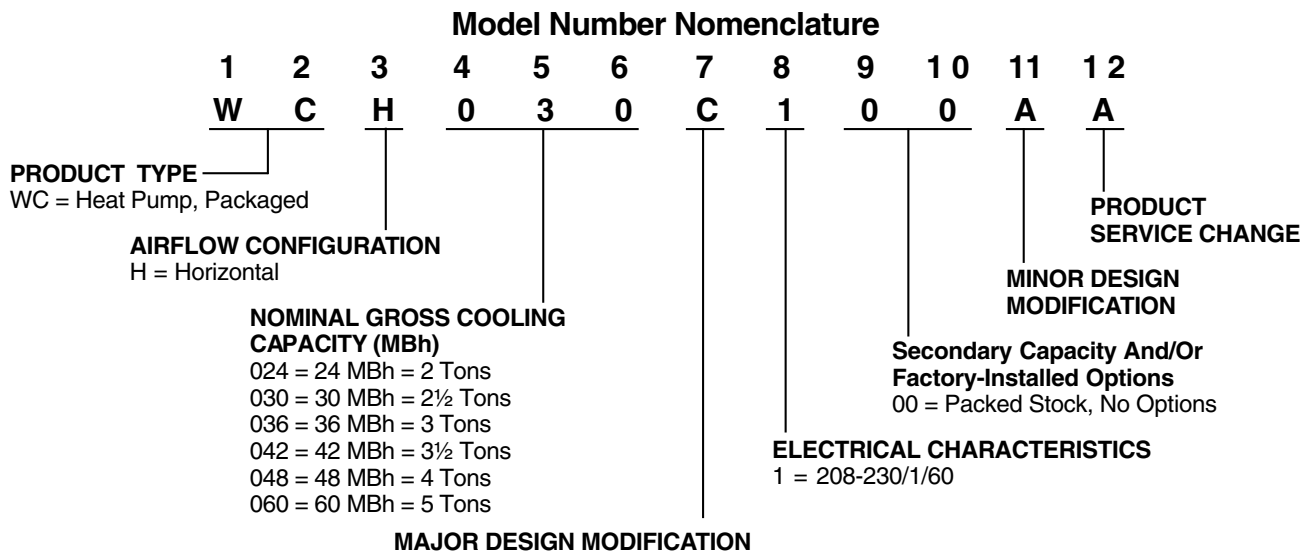



General Data

MODEL	WCH024C100A	WCH030C100A	WCH036C100B	WCH042C100A
RATED VOLTS/PH/Hz	208-230/1/60	208-230/1/60	208-230/1/60	208-230/1/60
PERFORMANCE (COOLING)^①				
BTUH	25000	27600	35000	40500
Indoor Air Flow (CFM)	800	1000	1200	1400
Power Input (KW)	2.1	2.43	3.08	3.58
EER/SEER (BTU/Watt-Hr.) ^⑥	11.88 / 13.0	11.25 / 13.5	11.39 / 13.0	10.66 / 13.0
Noise Rating No.(Decibels) ^②	78	75	75	77
PERFORMANCE (HEATING)^①				
(High Temp.) BTUH & C.O.P.	24000 - 3.48	27000 - 3.53	32600 - 3.59	37500 - 3.68
Power Input (KW)	2.03	2.26	2.67	3.02
(Low Temp.) BTUH & C.O.P.	14000 - 2.18	16000 - 2.30	19000 - 2.28	22400 - 2.40
Power Input (KW)	1.93	2.12	2.47	2.8
HSPF (BTU/Watt-Hr.) ^⑥	7.7	7.7	7.7	7.7
POWER CONNS. — V/PH/Hz				
Min. Brch. Cir. Ampacity ^③	16	21	23	28
Br. Cir. — Max. (Amps)	25	30	35	40
Prot. Rtg. — Recmd. (Amps)	25	30	35	40
COMPRESSOR				
No. Used — No. Speeds	CLIMATUFF® 1 - 1	CLIMATUFF® 1 - 1	CLIMATUFF® 1 - 1	CLIMATUFF® 1 - 1
Volts/PH/Hz	208-230/1/60	208-230/1/60	208-230/1/60	208-230/1/60
R.L. Amps — L.R. Amps	10.3 - 56	12.7 - 67	14.7 - 83	16.5 - 95
OUTDOOR COIL — TYPE				
Rows / F.P.I.	PLATE FIN 2 / 22	PLATE FIN 2 / 22	PLATE FIN 2 / 22	PLATE FIN 2 / 22
Face Area (Sq. Ft.)	112	112	112	12.3
Tube Size (in.)	0.375	0.375	0.375	0.375
Refrigerant Control	TXV-NB	TXV-NB	TXV-NB	TXV-NB
INDOOR COIL — TYPE				
Rows / F.P.I.	PLATE FIN 4 / 15	PLATE FIN 4 / 15	PLATE FIN 4 / 15	PLATE FIN 5 / 15
Face Area (Sq. Ft.)	3.44	3.44	3.44	3.44
Tube Size (in.)	0.375	0.375	0.375	0.375
Refrigerant Control	TXV-NB	TXV-NB	TXV-NB	TXV-NB
Drain Conn. Size (in.)	3/4 FPT - PVC	3/4 FEMALE PVC	3/4 FEMALE PVC	3/4 FEMALE PVC
Duct Connections	SEE OUTLINE DRAWING	SEE OUTLINE DRAWING	SEE OUTLINE DRAWING	SEE OUTLINE DRAWING
OUTDOOR FAN — TYPE				
No. Used / Dia. (in.)	PROPELLER 1 / 20	PROPELLER 1 / 20	PROPELLER 1 / 20	PROPELLER 1 / 20
Type Drive / No. Speeds	DIRECT / 1	DIRECT / 1	DIRECT / 1	DIRECT / 1
CFM @ a 0.0 In. W.G. ^④	2500	2500	2500	2600
No. Motors — HP	1 - 1/5	1 - 1/5	1 - 1/5	1 - 1/5
Motor Speed R.P.M.	850	850	850	850
Volts/PH/Hz	208-230/1/60	208-230/1/60	208-230/1/60	208-230/1/60
F.L. Amps — L.R. Amps	1.0 - 2.2	1.0 - 2.2	1.0 - 2.2	1.0 - 2.2
INDOOR FAN — TYPE				
Dia. x Width (in.)	CENTRIFUGAL 9 X 9	CENTRIFUGAL 10 X 10	CENTRIFUGAL 10 X 10	CENTRIFUGAL 10 X 10
No. Used	1	1	1	1
Drive / Speeds (No.)	DIRECT / 2	DIRECT / 2	DIRECT / 2	DIRECT / VAR
CFM vs. in. W.G. ^⑤	SEE FAN PERFORMANCE TABLE	SEE FAN PERFORMANCE TABLE	SEE FAN PERFORMANCE TABLE	SEE FAN PERFORMANCE TABLE
No. Motors — HP	1 - 0.25	1 - .50	1 - 0.50	1 - .75
Motor Speed R.P.M.	1075	1050	1050	VARIABLE
Volts/PH/Hz	208-230/1/60	208-230/1/60	208-230/1/60	208-230/1/60
F.L. Amps — L.R. Amps	1.8 - 6.8	4.0	4.1	6.8
FILTER — FURNISHED?				
Type Recommended	NO	NO	NO	NO
Min. Face Area ^⑦	THROWAWAY	THROWAWAY	THROWAWAY	THROWAWAY
Low Vel. (Sq. Ft.)	2.67	3.33	4.00	4.67
REFRIGERANT				
Charge (lbs. of R-22)	7 lbs., 8 oz.	7 lbs., 4 oz.	7 lbs.	8 lbs., 8 oz.
DIMENSIONS				
Crated (in.)	H X W X D 34 X 33.8 X 48	H X W X D 34 X 33.8 X 48	H X W X D 34 X 33.8 X 48	H X W X D 34 X 33.8 X 48
Uncrated	SEE OUTLINE DRAWING	SEE OUTLINE DRAWING	SEE OUTLINE DRAWING	SEE OUTLINE DRAWING
WEIGHT				
Shipping (lbs.) / Net (lbs.)	329 / 282	330 / 283	338 / 291	359 / 312

① Rated in accordance with A.R.I. Standard 210/240.

② Calculated in accordance with A.R.I. Standard 270.

③ Calculated in accordance with currently prevailing Nat'l. Electric Code.

④ Standard Air — Dry Coil — Outdoor.

⑤ Standard Air — Wet Coil — Indoor.

⑥ Rated in accordance with D.O.E. test procedure. HSPF is at the minimum design requirement of Region IV.

⑦ Filters must be installed in return air system. Square footages listed above are based on 300 F.P.M. face velocity. If permanent filters are used size per manufacturer's recommendations with clean resistance of 0.05" W.C.



General Data

MODEL	WCH048F100A	WCH060F100A
RATED VOLTS/PH/Hz	208-230/1/60	208-230/1/60
PERFORMANCE (COOLING)^①		
BTUH	49000	60000
Indoor Air Flow (CFM)	1600	1950
Power Input (KW)	4.05	5.41
EER/SEER (BTU/Watt-Hr.) ^⑥	12.00 / 13.50	11.30 / 13.00
Noise Rating No.(Decibels) ^②	84	84
PERFORMANCE (HEATING)^①		
(High Temp.) BTUH & C.O.P.	47500 - 3.54	56000 - 3.55
Power Input (KW)	3.96	4.68
(Low Temp.) BTUH & C.O.P.	29000 - 2.40	35000 - 2.39
Power Input (KW)	3.53	4.30
HSPF (BTU/Watt-Hr.) ^⑥	8.0	8.2
POWER CONNS. — V/PH/Hz		
Min. Brch. Cir. Ampacity ^③	37	48.0
Br. Cir. — Max. (Amps)	50	60
Prot. Rtg. — Recmd. (Amps)	50	60
COMPRESSOR		
No. Used — No. Speeds	CLIMATUFF® 1 - 1	CLIMATUFF® 1 - 1
Volts/PH/Hz	208-230/1/60	208-230/1/60
R.L. Amps — L.R. Amps	21.2 - 137	28.8 - 148
OUTDOOR COIL — TYPE		
Rows / F.P.I.	PLATE FIN 2 / 22	PLATE FIN 2 / 22
Face Area (Sq. Ft.)	14.31	14.31
Tube Size (in.)	3/8	3/8
Refrigerant Control	TXV-NB	TXV-NB
INDOOR COIL — TYPE		
Rows / F.P.I.	PLATE FIN 3 / 16	PLATE FIN 4 / 16
Face Area (Sq. Ft.)	5.31	5.31
Tube Size (in.)	3/8	3/8
Refrigerant Control	TXV-NB	TXV-NB
Drain Conn. Size (in.)	3/4 FPT - PVC	3/4 FEMALE PVC
Duct Connections	SEE OUTLINE DRAWING	SEE OUTLINE DRAWING
OUTDOOR FAN — TYPE		
No. Used / Dia. (in.)	PROPELLER 1 / 22	PROPELLER 1 / 22
Type Drive / No. Speeds	DIRECT / 1	DIRECT / 1
CFM @ a 0.0 In. W.G. ^④	4100	4100
No. Motors — HP	1 - 1/2	1 - 1/2
Motor Speed R.P.M.	1080	1080
Volts/PH/Hz	208-230/1/60	208-230/1/60
F.L. Amps — L.R. Amps	3.4 - 7.7	2.8 - 6.6
INDOOR FAN — TYPE		
Dia. x Width (in.)	CENTRIFUGAL 11 X 11	CENTRIFUGAL 11 X 11
No. Used	1	1
Drive / Speeds (No.)	DIRECT / VAR	DIRECT / VAR
CFM vs. in. W.G. ^⑤	SEE FAN PERFORMANCE TABLE	SEE FAN PERFORMANCE TABLE
No. Motors — HP	1 - .75	1 - 1
Motor Speed R.P.M.	VARIABLE	VARIABLE
Volts/PH/Hz	208-230/1/60	208-230/1/60
F.L. Amps — L.R. Amps	6.8	6.9
FILTER — FURNISHED?		
Type Recommended	NO	NO
Min. Face Area ^⑦	THROWAWAY	THROWAWAY
Low Vel. (Sq. Ft.)	4.17	5.31
REFRIGERANT		
Charge (lbs. of R-22)	11 lbs., 0 oz.	10 lbs., 11 oz.
DIMENSIONS		
Crated (in.)	H X W X D 39-3/8 X 47X 66	H X W X D 39-3/8 X 47X 66
Uncrated	SEE OUTLINE DRAWING	SEE OUTLINE DRAWING
WEIGHT		
Shipping (lbs.) / Net (lbs.)	521 / 449	529 / 457

① Rated in accordance with A.R.I. Standard 210/240.

② Calculated in accordance with A.R.I. Standard 270.

③ Calculated in accordance with currently prevailing Nat'l. Electric Code.

④ Standard Air — Dry Coil — Outdoor.

⑤ Standard Air — Wet Coil — Indoor.

⑥ Rated in accordance with D.O.E. test procedure. HSPF is at the minimum design requirement of Region IV.

⑦ Filters must be installed in return air system. Square footages listed above are based on 300 F.P.M. face velocity. If permanent filters are used size per manufacturer's recommendations with clean resistance of 0.05" W.C.



Performance Data Cooling

WCH024C1 AT 800 CFM (CAPACITIES ARE NET IN BTUH/1000-INDOOR FAN HEAT DEDUCTED)

O.D. D.B.	I.D. W.B.	TOTAL CAP.	SENS. CAP. AT ENTERING D.B. TEMP.					COMPR. KW	APP. DEW PT.	CORRECTION FACTORS - OTHER AIRFLOWS (MULTIPLY OR ADD AS INDICATED)		
			72	74	76	78	80					
85	59	22.5	18.8	20.4	21.9	22.9*	23.5*	1.41	47.0	AIRFLOW 700 800 TOTAL CAP. X0.98 X1.00 SENS. CAP. X0.94 X1.00 COMPR. KW X1.00 X1.00 A.D.P. -1.3 0.0		
	63	24.3	15.7	17.3	18.8	20.4	22.0	1.42	50.9			
	67	26.1	12.3	13.9	15.5	17.0	18.6	1.42	55.2			
	71	27.9	8.8	10.4	12.0	13.6	15.2	1.42	59.5			
90	59	22.0	18.6	20.1	21.7	22.5*	23.1*	1.51	47.3	VALUES AT ARI RATING CONDITIONS TOTAL NET CAPACITY = 25000 BTUH AIRFLOW = 800 CFM APP. DEW PT. = 55.7 DEG. F COMPRESSOR POWER = 1600 WATTS I.D. FAN POWER = 260 WATTS O.D. FAN POWER = 255 WATTS S.E.E.R. = 13.00 BTUH/WATT E.E.R. = 11.88 BTUH/WATT * DRY COIL CONDITION (TOTAL CAPACITY = SENSIBLE CAPACITY) TOTAL CAPACITY, COMP. KW AND APP. DEW PT. ARE VALID ONLY FOR WET COIL ALL TEMPERATURES IN DEGREES F.		
	63	23.8	15.5	17.1	18.6	20.2	21.8	1.51	51.2			
	67	25.5	12.1	13.7	15.2	16.8	18.4	1.51	55.4			
	71	27.4	8.6	10.2	11.8	13.4	15.0	1.51	59.7			
95	59	21.6	18.4	19.9	21.5	22.1*	22.7*	1.61	47.6			
	63	23.2	15.3	16.9	18.4	20.0	21.6	1.61	51.5			
	67	25.0	11.9	13.5	15.0	16.6	18.2	1.61	55.7			
	71	26.8	8.4	10.0	11.6	13.2	14.8	1.60	60.0			
100	59	21.0	18.1	19.7	21.2*	21.7*	22.2*	1.73	47.9			
	63	22.7	15.0	16.6	18.2	19.8	21.3	1.73	51.8			
	67	24.4	11.7	13.2	14.8	16.4	18.0	1.72	56.0			
	71	26.2	8.2	9.8	11.4	12.9	14.5	1.72	60.3			
105	59	20.5	17.9	19.5	20.7*	21.2*	21.8*	1.86	48.2			
	63	22.1	14.8	16.4	18.0	19.5	21.1	1.85	52.1			
	67	23.8	11.4	13.0	14.6	16.2	17.7	1.84	56.3			
	71	25.5	8.0	9.6	11.1	12.7	14.3	1.83	60.6			
115	59	19.4	17.4	19.0	19.8*	20.3*	20.9*	2.13	48.8			
	63	21.0	14.3	15.9	17.5	19.1	20.7	2.10	52.7			
	67	22.6	11.0	12.5	14.1	15.7	17.3	2.08	56.9			
	71	24.2	7.5	9.1	10.7	12.3	13.8	2.05	61.2			

WCH030C1 AT 1000 CFM (CAPACITIES ARE NET IN BTUH/1000-INDOOR FAN HEAT DEDUCTED)

O.D. D.B.	I.D. W.B.	TOTAL CAP.	SENS. CAP. AT ENTERING D.B. TEMP.					COMPR. KW	APP. DEW PT.	CORRECTION FACTORS - OTHER AIRFLOWS (MULTIPLY OR ADD AS INDICATED)		
			72	74	76	78	80					
85	59	27.1	22.5	24.4	26.2	27.5*	28.2*	1.69	46.8	AIRFLOW 875 1000 TOTAL CAP. X0.98 X1.00 SENS. CAP. X0.94 X1.00 COMPR. KW X1.00 X1.00 A.D.P. -1.3 0.0		
	63	29.2	18.7	20.6	22.5	24.4	26.3	1.70	50.7			
	67	31.3	14.7	16.6	18.4	20.3	22.2	1.71	54.9			
	71	33.5	10.5	12.4	14.3	16.2	18.1	1.72	59.3			
90	59	26.5	22.2	24.1	26.0	27.1*	27.7*	1.81	47.1	VALUES AT ARI RATING CONDITIONS TOTAL NET CAPACITY = 39400 BTUH AIRFLOW = 1000 CFM APP. DEW PT. = 55.5 DEG. F COMPRESSOR POWER = 1900 WATTS I.D. FAN POWER = 220 WATTS O.D. FAN POWER = 250 WATTS S.E.E.R. = 13.00 BTUH/WATT E.E.R. = 12.45 BTUH/WATT * DRY COIL CONDITION (TOTAL CAPACITY = SENSIBLE CAPACITY) TOTAL CAPACITY, COMP. KW AND APP. DEW PT. ARE VALID ONLY FOR WET COIL ALL TEMPERATURES IN DEGREES F.		
	63	28.6	18.5	20.4	22.3	24.2	26.0	1.82	51.0			
	67	30.7	14.4	16.3	18.2	20.1	22.0	1.82	55.2			
	71	32.8	10.3	12.2	14.1	15.9	17.8	1.83	59.5			
95	59	25.9	21.9	23.8	25.7	26.6*	27.2*	1.92	47.4			
	63	27.9	18.2	20.1	22.0	23.9	25.8	1.93	51.3			
	67	30.0	14.2	16.1	18.0	19.8	21.7	1.94	55.5			
	71	32.2	10.0	11.9	13.8	15.7	17.6	1.94	59.8			
100	59	25.2	21.7	23.5	25.4*	26.0*	26.6*	2.07	47.7			
	63	27.2	18.0	19.8	21.7	23.6	25.5	2.07	51.6			
	67	29.3	13.9	15.8	17.7	19.6	21.5	2.08	55.8			
	71	31.4	9.8	11.7	13.5	15.4	17.3	2.08	60.1			
105	59	24.6	21.4	23.3	24.8*	25.5*	26.1*	2.22	48.0			
	63	26.5	17.7	19.6	21.5	23.3	25.2	2.22	51.9			
	67	28.5	13.6	15.5	17.4	19.3	21.2	2.22	56.1			
	71	30.6	9.5	11.4	13.3	15.2	17.1	2.22	60.4			
115	59	23.2	20.8	22.7	23.7*	24.3*	24.9*	2.53	48.6			
	63	25.1	17.1	19.0	20.9	22.8	24.7	2.51	52.5			
	67	27.0	13.1	15.0	16.9	18.7	20.6	2.50	56.7			
	71	29.0	9.0	10.9	12.7	14.6	16.5	2.49	61.0			

WCH036C1 AT 1200 CFM (CAPACITIES ARE NET IN BTUH/1000-INDOOR FAN HEAT DEDUCTED)

O.D. D.B.	I.D. W.B.	TOTAL CAP.	SENS. CAP. AT ENTERING D.B. TEMP.					COMPR. KW	APP. DEW PT.	CORRECTION FACTORS - OTHER AIRFLOWS (MULTIPLY OR ADD AS INDICATED)		
			72	74	76	78	80					
85	59	32.6	27.2	29.4	31.7	33.1*	33.9*	2.16	47.0	AIRFLOW 1050 1200 TOTAL CAP. X0.98 X1.00 SENS. CAP. X0.94 X1.00 COMPR. KW X1.00 X1.00 A.D.P. -1.3 0.0		
	63	35.0	22.7	25.0	27.2	29.5	31.8	2.18	50.9			
	67	37.5	17.8	20.1	22.3	24.6	26.9	2.21	55.1			
	71	40.2	12.8	15.1	17.3	19.6	21.9	2.23	59.5			
90	59	31.9	26.9	29.2	31.4	32.6*	33.4*	2.29	47.2	VALUES AT ARI RATING CONDITIONS TOTAL NET CAPACITY = 35000 BTUH AIRFLOW = 1200 CFM APP. DEW PT. = 55.7 DEG. F COMPRESSOR POWER = 2480 WATTS I.D. FAN POWER = 280 WATTS O.D. FAN POWER = 250 WATTS S.E.E.R. = 13.00 BTUH/WATT E.E.R. = 11.39 BTUH/WATT * DRY COIL CONDITION (TOTAL CAPACITY = SENSIBLE CAPACITY) TOTAL CAPACITY, COMP. KW AND APP. DEW PT. ARE VALID ONLY FOR WET COIL ALL TEMPERATURES IN DEGREES F.		
	63	34.3	22.4	24.7	27.0	29.2	31.5	2.31	51.2			
	67	36.8	17.5	19.8	22.0	24.3	26.6	2.34	55.4			
	71	39.3	12.5	14.8	17.0	19.3	21.6	2.37	59.7			
95	59	31.3	26.6	28.9	31.1	32.1*	32.8*	2.42	47.5			
	63	33.6	22.1	24.4	26.7	28.9	31.2	2.45	51.4			
	67	36.0	17.2	19.5	21.7	24.0	26.3	2.48	55.7			
	71	38.5	12.2	14.5	16.7	19.0	21.3	2.51	60.0			
100	59	30.5	26.3	28.6	30.7*	31.4*	32.2*	2.57	47.8			
	63	32.8	21.8	24.1	26.3	28.6	30.9	2.61	51.8			
	67	35.1	16.9	19.2	21.4	23.7	25.9	2.64	56.0			
	71	37.5	11.9	14.1	16.4	18.7	20.9	2.68	60.4			
105	59	29.8	26.0	28.2	30.1*	30.8*	31.5*	2.73	48.1			
	63	32.0	21.5	23.7	26.0	28.3	30.5	2.77	52.1			
	67	34.2	16.6	18.8	21.1	23.3	25.6	2.81	56.3			
	71	36.6	11.5	13.8	16.1	18.3	20.6	2.85	60.7			
115	59	28.2	25.3	27.6	28.8*	29.5*	30.2*	3.04	48.7			
	63	30.3	20.8	23.1	25.3	27.6	29.9	3.08	52.7			
	67	32.4	15.9	18.2	20.4	22.7	24.9	3.13	57.0			
	71	34.6	10.9	13.1	15.4	17.7	19.9	3.18	61.3			



Performance Data Cooling

WCH042C1 AT 1400 CFM (CAPACITIES ARE NET IN BTUH/1000-INDOOR FAN HEAT DEDUCTED)

O.D. D.B.	I.D. W.B.	TOTAL CAP.	SENS. CAP. AT ENTERING D.B. TEMP.					COMPR. KW	APP. DEW PT.	
			72	74	76	78	80			
85	59	38.4	33.1	35.9	38.5*	39.5*	40.4*	2.79	47.7	CORRECTION FACTORS - OTHER AIRFLOWS (MULTIPLY OR ADD AS INDICATED) AIRFLOW 1225 1400 TOTAL CAP. X0.99 X1.00 SENS. CAP. X0.94 X1.00 COMPR. KW X1.00 X1.00 A.D.P. -1.4 0.0 VALUES AT ARI RATING CONDITIONS TOTAL NET CAPACITY = 40500 BTUH AIRFLOW = 1400 CFM APP. DEW PT. = 56.6 DEG. F COMPRESSOR POWER = 3218 WATTS I.D. FAN POWER = 490 WATTS O.D. FAN POWER = 250 WATTS S.E.E.R. = 13.00 BTUH/WATT E.E.R. = 11.37 BTUH/WATT * DRY COIL CONDITION (TOTAL CAPACITY = SENSIBLE CAPACITY) TOTAL CAPACITY, COMP. KW AND APP. DEW PT. ARE VALID ONLY FOR WET COIL ALL TEMPERATURES IN DEGREES F.
	63	41.1	27.5	30.3	33.1	35.9	38.8	2.83	51.7	
	67	44.0	21.3	24.1	27.0	29.8	32.6	2.86	56.0	
	71	46.9	15.0	17.9	20.7	23.5	26.3	2.90	60.4	
90	59	37.6	32.7	35.6	37.8*	38.8*	39.7*	2.96	48.0	
	63	40.2	27.1	29.9	32.7	35.6	38.4	3.00	52.0	
	67	43.0	20.9	23.8	26.6	29.4	32.2	3.04	56.3	
	71	45.9	14.7	17.5	20.3	23.1	25.9	3.08	60.7	
95	59	36.7	32.4	35.2	37.2*	38.1*	38.9*	3.13	48.3	
	63	39.3	26.7	29.5	32.4	35.2	38.0	3.17	52.3	
	67	42.0	20.6	23.4	26.2	29.0	31.8	3.22	56.6	
	71	44.8	14.3	17.1	19.9	22.7	25.6	3.27	61.0	
100	59	35.8	32.0	34.8	36.4*	37.3*	38.1*	3.33	48.6	
	63	38.3	26.3	29.1	31.9	34.8	37.6	3.38	52.6	
	67	41.0	20.1	23.0	25.8	28.6	31.4	3.43	56.9	
	71	43.7	13.9	16.7	19.5	22.3	25.1	3.48	61.3	
105	59	34.9	31.5	34.4	35.6*	36.5*	37.3*	3.52	48.9	
	63	37.3	25.9	28.7	31.5	34.3	37.2	3.58	52.9	
	67	39.9	19.7	22.5	25.4	28.2	31.0	3.64	57.2	
	71	42.5	13.4	16.3	19.1	21.9	24.7	3.70	61.6	
115	59	33.0	30.7	33.1*	34.0*	34.8*	35.6*	3.91	49.5	
	63	35.3	25.0	27.9	30.7	33.5	36.2*	3.98	53.5	
	67	37.7	18.9	21.7	24.5	27.3	30.2	4.05	57.8	
	71	40.2	12.6	15.4	18.3	21.1	23.9	4.13	62.2	

WCH048F AT 1600 CFM (CAPACITIES ARE NET IN BTUH/1000-INDOOR FAN HEAT DEDUCTED)

O.D. D.B.	I.D. W.B.	TOTAL CAP.	SENS. CAP. AT ENTERING D.B. TEMP.					COMPR. KW	APP. DEW PT.	
			72	74	76	78	80			
85	59	44.4	36.1	38.9	41.7	44.5*	45.6*	3.63	46.1	CORRECTION FACTORS - OTHER AIRFLOWS (MULTIPLY OR ADD AS INDICATED) AIRFLOW 1400 1600 TOTAL CAP. X0.98 X1.00 SENS. CAP. X0.94 X1.00 COMPR. KW X1.00 X1.00 A.D.P. -1.5 0.0 VALUES AT ARI RATING CONDITIONS TOTAL NET CAPACITY = 49000 BTUH AIRFLOW = 1600 CFM APP. DEW PT. = 54.9 DEG. F COMPRESSOR POWER = 3285 WATTS I.D. FAN POWER = 270 WATTS O.D. FAN POWER = 500 WATTS S.E.E.R. = 13.00 BTUH/WATT E.E.R. = 12.00 BTUH/WATT * DRY COIL CONDITION (TOTAL CAPACITY = SENSIBLE CAPACITY) TOTAL CAPACITY, COMP. KW AND APP. DEW PT. ARE VALID ONLY FOR WET COIL ALL TEMPERATURES IN DEGREES F.
	63	47.7	30.5	33.3	36.1	39.0	41.8	3.67	50.0	
	67	51.0	24.3	27.1	29.9	32.8	35.6	3.70	54.2	
	71	54.5	17.9	20.7	23.6	26.4	29.3	3.74	58.5	
90	59	43.6	35.7	38.5	41.4	43.8*	44.9*	3.80	46.4	
	63	46.7	30.1	32.9	35.7	38.6	41.4	3.84	50.4	
	67	50.0	23.9	26.7	29.5	32.4	35.2	3.88	54.6	
	71	53.4	17.5	20.3	23.2	26.0	28.9	3.92	58.9	
95	59	42.7	35.3	38.2	41.0	43.1*	44.2*	3.96	46.7	
	63	45.8	29.7	32.5	35.4	38.2	41.0	4.01	50.7	
	67	49.0	23.5	26.3	29.1	32.0	34.8	4.06	54.9	
	71	52.3	17.1	20.0	22.8	25.6	28.5	4.10	59.2	
100	59	41.7	34.9	37.7	40.5	42.4*	43.4*	4.17	47.1	
	63	44.7	29.2	32.1	34.9	37.7	40.6	4.22	51.0	
	67	47.8	23.0	25.8	28.7	31.5	34.4	4.28	55.3	
	71	51.0	16.7	19.5	22.3	25.2	28.0	4.33	59.6	
105	59	40.8	34.4	37.3	40.1	41.6*	42.5*	4.37	47.4	
	63	43.7	28.8	31.6	34.5	37.3	40.1	4.44	51.4	
	67	46.7	22.6	25.4	28.2	31.1	33.9	4.50	55.6	
	71	49.8	16.2	19.1	21.9	24.7	27.6	4.57	59.9	
115	59	38.8	33.6	36.4	38.9*	39.9*	40.8*	4.77	48.1	
	63	41.5	27.9	30.7	33.6	36.4	39.3	4.86	52.1	
	67	44.3	21.7	24.5	27.3	30.2	33.0	4.95	56.3	
	71	47.3	15.3	18.2	21.0	23.8	26.7	5.04	60.7	

WCH060F AT 2000 CFM (CAPACITIES ARE NET IN BTUH/1000-INDOOR FAN HEAT DEDUCTED)

O.D. D.B.	I.D. W.B.	TOTAL CAP.	SENS. CAP. AT ENTERING D.B. TEMP.					COMPR. KW	APP. DEW PT.	
			72	74	76	78	80			
85	59	54.4	45.5	49.3	53.1	55.4*	56.6*	4.82	47.0	CORRECTION FACTORS - OTHER AIRFLOWS (MULTIPLY OR ADD AS INDICATED) AIRFLOW 1750 2000 TOTAL CAP. X0.98 X1.00 SENS. CAP. X0.94 X1.00 COMPR. KW X1.00 X1.00 A.D.P. -1.4 0.0 VALUES AT ARI RATING CONDITIONS TOTAL NET CAPACITY = 60000 BTUH AIRFLOW = 2000 CFM APP. DEW PT. = 55.8 DEG. F COMPRESSOR POWER = 4480 WATTS I.D. FAN POWER = 500 WATTS O.D. FAN POWER = 435 WATTS S.E.E.R. = 13.00 BTUH/WATT E.E.R. = 11.31 BTUH/WATT * DRY COIL CONDITION (TOTAL CAPACITY = SENSIBLE CAPACITY) TOTAL CAPACITY, COMP. KW AND APP. DEW PT. ARE VALID ONLY FOR WET COIL ALL TEMPERATURES IN DEGREES F.
	63	58.4	38.0	41.8	45.6	49.4	53.1	4.86	51.0	
	67	62.5	29.8	33.6	37.4	41.1	44.9	4.91	55.2	
	71	66.8	21.4	25.2	29.0	32.8	36.5	4.95	59.6	
90	59	53.4	45.1	48.8	52.6	54.5*	55.7*	5.05	47.3	
	63	57.2	37.6	41.3	45.1	48.9	52.7	5.10	51.3	
	67	61.3	29.3	33.1	36.9	40.7	44.4	5.15	55.5	
	71	65.4	21.0	24.7	28.5	32.3	36.0	5.20	59.9	
95	59	52.3	44.6	48.4	52.1	53.6*	54.8*	5.28	47.6	
	63	56.1	37.1	40.9	44.6	48.4	52.2	5.34	51.5	
	67	60.0	28.9	32.6	36.4	40.2	43.9	5.39	55.8	
	71	64.1	20.5	24.2	28.0	31.8	35.6	5.45	60.1	
100	59	51.1	44.1	47.9	51.3*	52.6*	53.8*	5.56	47.9	
	63	54.8	36.6	40.3	44.1	47.9	51.7	5.62	51.8	
	67	58.6	28.3	32.1	35.9	39.6	43.4	5.68	56.1	
	71	62.5	19.9	23.7	27.5	31.3	35.0	5.74	60.5	
105	59	49.9	43.6	47.3	50.4*	51.6*	52.8*	5.83	48.2	
	63	53.5	36.0	39.8	43.6	47.4	51.1	5.90	52.1	
	67	57.2	27.8	31.6	35.3	39.1	42.9	5.97	56.4	
	71	61.0	19.4	23.2	26.9	30.7	34.5	6.04	60.8	
115	59	47.6	42.5	46.3	48.4*	49.6*	50.7*	6.36	48.7	
	63	50.9	35.0	38.8	42.5	46.3	50.1	6.45	52.7	
	67	54.4	26.7	30.5	34.3	38.1	41.8	6.54	57.0	
	71	58.0	18.3	22.1	25.9	29.7	33.4	6.64	61.4	



Performance Data

Heating

WCH024C1 AT 800 CFM

O.D. TEMP. F.	HEATING CAPACITY (BTUH/1000) AT INDICATED INDOOR DRY BULB TEMP.				TOTAL POWER IN KILOWATTS AT INDICATED INDOOR DRY BULB TEMP.				CORRECTION FACTORS - OTHER AIRFLOWS (VALUE AT 800 CFM TIMES CORR. FACTOR = VALUE AT NEW AIRFLOW)
	60	70	75	80	60	70	75	80	
-3	7.43	7.33	7.28	7.23	1.72	1.87	1.95	2.02	AIRFLOW = 700 800 HEATING CAP. X0.99 X1.00 COMPR. KW X1.03 X1.00 VALUES AT ARI RATING CONDITIONS OF: 70&47/43 (HIGH TEMP. POINT) 70&17/15 (LOW TEMP. POINT) AIRFLOW = 800 CFM HEATING CAP. (HIGH TEMP.) = 24000 BTUH HEATING CAP. (LOW TEMP.) = 14000 BTUH COMPR. POWER (HIGH TEMP.) = 1500 WATTS COMPR. POWER (LOW TEMP.) = 1435 WATTS HSPF (MIN DHR) = 7.70 COEFF. OF PERF. (HIGH TEMP.) = 3.48 COEFF. OF PERF. (LOW TEMP.) = 2.18 OUTDOOR FAN POWER = 280 WATTS INDOOR FAN POWER = 250 WATTS
2	9.13	9.00	8.94	8.87	1.74	1.89	1.96	2.04	
7	10.8	10.7	10.6	10.5	1.75	1.90	1.98	2.06	
12	12.5	12.3	12.2	12.2	1.77	1.92	2.00	2.07	
17	14.2	14.0	13.9	13.8	1.78	1.94	2.01	2.09	
22	15.0	14.8	14.7	14.6	1.79	1.95	2.03	2.10	
27	15.8	15.5	15.4	15.3	1.80	1.96	2.04	2.12	
32	16.5	16.3	16.2	16.1	1.81	1.97	2.05	2.13	
37	17.3	17.1	16.9	16.8	1.83	1.99	2.06	2.14	
42	18.1	17.8	17.7	17.6	1.84	2.00	2.08	2.16	
47	24.4	24.0	23.8	23.6	1.87	2.03	2.11	2.19	
52	26.0	25.7	25.5	25.3	1.88	2.05	2.13	2.21	
57	27.7	27.3	27.1	26.9	1.90	2.06	2.14	2.23	
62	29.4	29.0	28.8	28.6	1.91	2.08	2.16	2.25	
67	31.1	30.7	30.4	30.2	1.92	2.09	2.18	2.26	
72	32.8	32.3	32.1	31.9	1.94	2.11	2.19	2.28	

WCH030C1 AT 1000 CFM

O.D. TEMP. F.	HEATING CAPACITY (BTUH/1000) AT INDICATED INDOOR DRY BULB TEMP.				TOTAL POWER IN KILOWATTS AT INDICATED INDOOR DRY BULB TEMP.				CORRECTION FACTORS - OTHER AIRFLOWS (VALUE AT 1000 CFM TIMES CORR. FACTOR = VALUE AT NEW AIRFLOW)
	60	70	75	80	60	70	75	80	
-3	8.79	8.67	8.61	8.55	1.82	1.98	2.06	2.14	AIRFLOW = 875 1000 HEATING CAP. X0.99 X1.00 COMPR. KW X1.03 X1.00 VALUES AT ARI RATING CONDITIONS OF: 70&47/43 (HIGH TEMP. POINT) 70&17/15 (LOW TEMP. POINT) AIRFLOW = 1000 CFM HEATING CAP. (HIGH TEMP.) = 27000 BTUH HEATING CAP. (LOW TEMP.) = 16000 BTUH COMPR. POWER (HIGH TEMP.) = 1760 WATTS COMPR. POWER (LOW TEMP.) = 1610 WATTS HSPF (MIN DHR) = 7.70 COEFF. OF PERF. (HIGH TEMP.) = 3.53 COEFF. OF PERF. (LOW TEMP.) = 2.31 OUTDOOR FAN POWER = 250 WATTS INDOOR FAN POWER = 220 WATTS
2	10.6	10.5	10.4	10.4	1.84	2.01	2.09	2.17	
7	12.5	12.3	12.2	12.2	1.86	2.03	2.11	2.20	
12	14.4	14.2	14.1	14.0	1.88	2.06	2.14	2.23	
17	16.2	16.0	15.9	15.8	1.91	2.08	2.17	2.25	
22	17.4	17.1	17.0	16.9	1.92	2.09	2.18	2.27	
27	18.5	18.2	18.1	18.0	1.93	2.10	2.19	2.28	
32	19.6	19.3	19.2	19.0	1.94	2.11	2.20	2.29	
37	20.7	20.4	20.3	20.1	1.95	2.12	2.21	2.30	
42	21.9	21.6	21.4	21.2	1.96	2.14	2.23	2.31	
47	27.4	27.0	26.8	26.6	2.04	2.23	2.32	2.42	
52	29.3	28.8	28.6	28.4	2.06	2.26	2.35	2.45	
57	31.1	30.7	30.4	30.2	2.09	2.28	2.38	2.47	
62	33.0	32.5	32.3	32.0	2.11	2.31	2.40	2.50	
67	34.8	34.3	34.1	33.8	2.13	2.33	2.43	2.53	
72	36.7	36.2	35.9	35.6	2.16	2.36	2.45	2.55	

WCH036C1 AT 1200 CFM

O.D. TEMP. F.	HEATING CAPACITY (BTUH/1000) AT INDICATED INDOOR DRY BULB TEMP.				TOTAL POWER IN KILOWATTS AT INDICATED INDOOR DRY BULB TEMP.				CORRECTION FACTORS - OTHER AIRFLOWS (VALUE AT 1200 CFM TIMES CORR. FACTOR = VALUE AT NEW AIRFLOW)
	60	70	75	80	60	70	75	80	
-8	9.35	9.08	8.95	8.82	2.10	2.27	2.36	2.45	AIRFLOW = 1050 1200 HEATING CAP. X0.99 X1.00 COMPR. KW X1.02 X1.00 VALUES AT ARI RATING CONDITIONS OF: 70&47/43 (HIGH TEMP. POINT) 70&17/15 (LOW TEMP. POINT) AIRFLOW = 1200 CFM HEATING CAP. (HIGH TEMP.) = 32600 BTUH HEATING CAP. (LOW TEMP.) = 19000 BTUH COMPR. POWER (HIGH TEMP.) = 2131 WATTS COMPR. POWER (LOW TEMP.) = 1920 WATTS HSPF (MIN DHR) = 7.70 COEFF. OF PERF. (HIGH TEMP.) = 3.59 COEFF. OF PERF. (LOW TEMP.) = 2.34 OUTDOOR FAN POWER = 250 WATTS INDOOR FAN POWER = 280 WATTS
-3	11.5	11.2	11.0	10.8	2.14	2.31	2.40	2.48	
2	13.6	13.3	13.1	12.9	2.17	2.34	2.43	2.52	
7	15.8	15.3	15.1	14.9	2.20	2.38	2.47	2.56	
12	18.0	17.4	17.1	16.9	2.23	2.41	2.51	2.60	
17	20.1	19.5	19.2	18.9	2.26	2.45	2.54	2.64	
22	20.8	20.2	19.9	19.6	2.30	2.49	2.58	2.68	
27	21.5	20.9	20.6	20.2	2.33	2.53	2.62	2.72	
32	22.3	21.6	21.2	20.9	2.37	2.57	2.66	2.76	
37	23.0	22.3	21.9	21.6	2.41	2.61	2.71	2.81	
42	23.7	23.0	22.6	22.3	2.44	2.64	2.75	2.85	
47	33.0	32.0	31.5	31.0	2.46	2.66	2.76	2.87	
52	35.2	34.1	33.5	33.0	2.49	2.70	2.80	2.90	
57	37.3	36.2	35.6	35.0	2.52	2.73	2.84	2.94	
62	39.5	38.3	37.6	37.0	2.55	2.77	2.87	2.98	
67	41.6	40.3	39.7	39.1	2.59	2.80	2.91	3.02	
72	43.8	42.4	41.7	41.1	2.62	2.84	2.95	3.06	



Performance Data Heating

WCH042C1 AT 1400 CFM

O.D. TEMP. F.	HEATING CAPACITY (BTUH/1000) AT INDICATED INDOOR DRY BULB TEMP.				TOTAL POWER IN KILOWATTS AT INDICATED INDOOR DRY BULB TEMP.				CORRECTION FACTORS - OTHER AIRFLOWS (VALUE AT 1400 CFM TIMES CORR. FACTOR = VALUE AT NEW AIRFLOW)
	60	70	75	80	60	70	75	80	
-8	10.3	10.0	9.87	9.74	2.42	2.61	2.70	2.79	AIRFLOW 1225 1400 HEATING CAP. X0.99 X1.00 COMPR. KW X1.02 X1.00 VALUES AT ARI RATING CONDITIONS OF: 70&47/43 (HIGH TEMP. POINT) 70&17/15 (LOW TEMP. POINT) AIRFLOW = 1400 CFM HEATING CAP. (HIGH TEMP.) = 37500 BTUH HEATING CAP. (LOW TEMP.) = 22400 BTUH COMPR. POWER (HIGH TEMP.) = 2259 WATTS COMPR. POWER (LOW TEMP.) = 2040 WATTS HSPF (MIN DHR) = 7.70 COEFF. OF PERF. (HIGH TEMP.) = 3.68 COEFF. OF PERF. (LOW TEMP.) = 2.40 OUTDOOR FAN POWER = 250 WATTS INDOOR FAN POWER = 500 WATTS
-3	12.8	12.5	12.3	12.2	2.46	2.64	2.74	2.83	
2	15.4	15.0	14.8	14.6	2.49	2.68	2.78	2.87	
7	18.0	17.5	17.3	17.0	2.52	2.72	2.81	2.91	
12	20.6	20.0	19.7	19.4	2.56	2.75	2.85	2.95	
17	23.2	22.5	22.2	21.8	2.59	2.79	2.89	2.99	
22	24.2	23.5	23.1	22.8	2.62	2.83	2.93	3.03	
27	25.2	24.4	24.1	23.7	2.66	2.86	2.97	3.07	
32	26.2	25.4	25.0	24.7	2.69	2.90	3.00	3.11	
37	27.2	26.4	26.0	25.6	2.72	2.93	3.04	3.15	
42	28.2	27.4	27.0	26.6	2.75	2.97	3.08	3.19	
47	38.6	37.5	36.9	36.4	2.79	3.01	3.12	3.23	
52	41.2	40.0	39.4	38.8	2.82	3.05	3.16	3.27	
57	43.8	42.5	41.9	41.2	2.86	3.08	3.20	3.31	
62	46.4	45.0	44.3	43.6	2.89	3.12	3.23	3.35	
67	48.9	47.5	46.8	46.1	2.92	3.16	3.27	3.39	
72	51.5	50.0	49.2	48.5	2.96	3.19	3.31	3.43	

WCH048F AT 1600 CFM

O.D. TEMP. F.	HEATING CAPACITY (BTUH/1000) AT INDICATED INDOOR DRY BULB TEMP.				TOTAL POWER IN KILOWATTS AT INDICATED INDOOR DRY BULB TEMP.				CORRECTION FACTORS - OTHER AIRFLOWS (VALUE AT 1600 CFM TIMES CORR. FACTOR = VALUE AT NEW AIRFLOW)
	60	70	75	80	60	70	75	80	
-8	14.1	14.0	13.9	13.9	2.94	3.18	3.30	3.42	AIRFLOW 1400 1600 HEATING CAP. X0.99 X1.00 COMPR. KW X1.03 X1.00 VALUES AT ARI RATING CONDITIONS OF: 70&47/43 (HIGH TEMP. POINT) 70&17/15 (LOW TEMP. POINT) AIRFLOW = 1600 CFM HEATING CAP. (HIGH TEMP.) = 47500 BTUH HEATING CAP. (LOW TEMP.) = 29000 BTUH COMPR. POWER (HIGH TEMP.) = 3190 WATTS COMPR. POWER (LOW TEMP.) = 2765 WATTS HSPF (MIN DHR) = 8.00 COEFF. OF PERF. (HIGH TEMP.) = 3.54 COEFF. OF PERF. (LOW TEMP.) = 2.40 OUTDOOR FAN POWER = 500 WATTS INDOOR FAN POWER = 270 WATTS
-3	17.2	17.0	16.9	16.8	3.01	3.25	3.37	3.49	
2	20.2	20.0	19.9	19.8	3.07	3.32	3.45	3.57	
7	23.2	23.0	22.9	22.8	3.14	3.39	3.52	3.65	
12	26.2	26.0	25.9	25.8	3.20	3.46	3.59	3.72	
17	29.3	29.0	28.9	28.7	3.27	3.54	3.67	3.80	
22	31.1	30.8	30.7	30.5	3.30	3.57	3.70	3.84	
27	32.9	32.6	32.5	32.3	3.33	3.60	3.74	3.88	
32	34.7	34.4	34.3	34.1	3.36	3.64	3.78	3.91	
37	36.6	36.2	36.0	35.9	3.40	3.67	3.81	3.95	
42	38.4	38.0	37.8	37.7	3.43	3.71	3.85	3.99	
47	47.5	47.0	46.8	46.5	3.66	3.96	4.11	4.26	
52	50.5	50.0	49.8	49.5	3.72	4.03	4.18	4.34	
57	53.5	53.0	52.7	52.5	3.79	4.10	4.26	4.41	
62	56.5	56.0	55.7	55.5	3.85	4.17	4.33	4.49	
67	59.6	59.0	58.7	58.4	3.92	4.24	4.41	4.57	
72	62.6	62.0	61.7	61.4	3.98	4.31	4.48	4.64	

WCH060F AT 2000 CFM

O.D. TEMP. F.	HEATING CAPACITY (BTUH/1000) AT INDICATED INDOOR DRY BULB TEMP.				TOTAL POWER IN KILOWATTS AT INDICATED INDOOR DRY BULB TEMP.				CORRECTION FACTORS - OTHER AIRFLOWS (VALUE AT 2000 CFM TIMES CORR. FACTOR = VALUE AT NEW AIRFLOW)
	60	70	75	80	60	70	75	80	
-8	17.6	17.5	17.4	17.4	3.69	3.99	4.14	4.29	AIRFLOW 1750 2000 HEATING CAP. X0.99 X1.00 COMPR. KW X1.02 X1.00 VALUES AT ARI RATING CONDITIONS OF: 70&47/43 (HIGH TEMP. POINT) 70&17/15 (LOW TEMP. POINT) AIRFLOW = 2000 CFM HEATING CAP. (HIGH TEMP.) = 56000 BTUH HEATING CAP. (LOW TEMP.) = 35000 BTUH COMPR. POWER (HIGH TEMP.) = 3755 WATTS COMPR. POWER (LOW TEMP.) = 3375 WATTS HSPF (MIN DHR) = 8.20 COEFF. OF PERF. (HIGH TEMP.) = 3.55 COEFF. OF PERF. (LOW TEMP.) = 2.39 OUTDOOR FAN POWER = 435 WATTS INDOOR FAN POWER = 500 WATTS
-3	21.1	21.0	20.9	20.9	3.75	4.06	4.21	4.36	
2	24.7	24.5	24.4	24.3	3.81	4.12	4.28	4.43	
7	28.2	28.0	27.9	27.8	3.87	4.18	4.34	4.50	
12	31.7	31.5	31.4	31.3	3.92	4.25	4.41	4.57	
17	35.2	35.0	34.9	34.8	3.98	4.31	4.47	4.64	
22	36.4	36.1	36.0	35.9	4.04	4.37	4.53	4.70	
27	37.5	37.2	37.1	37.0	4.09	4.43	4.60	4.76	
32	38.6	38.3	38.2	38.1	4.14	4.49	4.66	4.83	
37	39.7	39.4	39.3	39.2	4.20	4.54	4.72	4.89	
42	40.8	40.6	40.4	40.3	4.25	4.60	4.78	4.95	
47	56.4	56.0	55.8	55.6	4.33	4.69	4.87	5.05	
52	59.9	59.5	59.3	59.1	4.39	4.75	4.94	5.12	
57	63.4	63.0	62.8	62.6	4.45	4.82	5.00	5.19	
62	67.0	66.5	66.3	66.0	4.50	4.88	5.07	5.26	
67	70.5	70.0	69.8	69.5	4.56	4.94	5.13	5.32	
72	74.0	73.5	73.2	73.0	4.62	5.01	5.20	5.39	



Fan Performance Data

INDOOR BLOWER PERFORMANCE TCH, WCH024C

MOTOR SPEED		EXTERNAL STATIC PRESSURE-IN. W.G.				
		0.2	0.3	0.4	0.5	0.6
② LOW	WATTS	273	258	245	229	---
	CFM	875	811	761	697	---
HIGH	WATTS	354	338	325	312	293
	CFM	1047	994	928	864	767

D672418

- ① - WET COIL, NO FILTERS
- ② - FACTORY SETTING

INDOOR BLOWER PERFORMANCE TCH, WCH030C

MOTOR SPEED		EXTERNAL STATIC PRESSURE-IN. W.G.			
		0.2	0.3	0.4	0.5
② LOW	WATTS	220	225	245	---
	CFM	1060	1005	965	---
HIGH	WATTS	260	270	280	285
	CFM	1135	1090	1055	1015

D672417

- ① - WET COIL, NO FILTERS
- ② - FACTORY SETTING

INDOOR BLOWER PERFORMANCE TCH, WCH036C

MOTOR SPEED		EXTERNAL STATIC PRESSURE (IN. WG)			
		0.2	0.3	0.4	0.5
② LOW	WATTS	325	330	340	350
	CFM	1205	1160	1115	1075
HIGH	WATTS	410	415	410	395
	CFM	1325	1275	1215	1150

D674375

- ① - WET COIL, NO FILTERS
- ② - FACTORY SETTING

INDOOR BLOWER PERFORMANCE TCH, WCH042C

AIRFLOW SETTING	DIPSWITCH SETTINGS				EXTERNAL STATIC PRESSURE - IN. W.G.											
					.20 ①		.30 ①		.40 ①		.50 ①		.60 ①		.70 ①	
					CFM	PWR WATTS	CFM	PWR WATTS	CFM	PWR WATTS	CFM	PWR WATTS	CFM	PWR WATTS	CFM	PWR WATTS
350 CFM/TON	OFF	OFF	OFF	ON	1256	352	1265	392	1270	430	1265	465	1266	505	1266	530
400 CFM/TON	OFF	OFF	OFF	OFF	1386	480	1386	486	1395	535	1395	575	1389	594	1391	607
450 CFM/TON	OFF	OFF	ON	OFF	1557	530	1552	571	1551	604	1553	647	1555	690	1563	737

D672415 REV 0

- ① - WET COIL, NO FILTERS
- ② - FACTORY SETTING



Fan Performance Data

INDOOR BLOWER PERFORMANCE TCH, WCH048F

AIRFLOW SETTING	DIPSWITCH SETTINGS				EXTERNAL STATIC PRESSURE - IN. W.G.											
					.20 ①		.30 ①		.40 ①		.50 ①		.60 ①		.70 ①	
	1	2	3	4	CFM	PWR WATTS	CFM	PWR WATTS	CFM	PWR WATTS	CFM	PWR WATTS	CFM	PWR WATTS	CFM	PWR WATTS
350 CFM/TON	OFF	OFF	OFF	ON	1380	160	1390	195	1390	225	1390	260	1390	290	1365	335
400 CFM/TON ②	OFF	OFF	OFF	OFF	1613	225	1625	260	1640	305	1640	340	1640	370	1625	405
450 CFM/TON	OFF	OFF	ON	OFF	1760	270	1770	310	1775	345	1785	390	1785	435	1785	480

① - WET COIL, NO FILTERS

② - FACTORY SETTINGS

INDOOR BLOWER PERFORMANCE TCH, WCH060F

AIRFLOW SETTING	DIPSWITCH SETTINGS				EXTERNAL STATIC PRESSURE - IN. W.G.																	
					.20 ①			.30 ①			.50 ①			.70 ①			.90 ①			1.0 ①		
	1	2	3	4	CFM	PWR WATTS	BHP	CFM	PWR WATTS	BHP	CFM	PWR WATTS	BHP	CFM	PWR WATTS	BHP	CFM	PWR WATTS	BHP	CFM	PWR WATTS	BHP
350 CFM/TON	OFF	OFF	OFF	ON	1740	285	.26	1750	330	.31	1725	395	.37	1710	470	.43	1675	550	.51	1650	590	.55
400 CFM/TON ②	OFF	OFF	OFF	OFF	1990	385	.36	2010	440	.41	2020	520	.48	2005	590	.55	1990	690	.64	1895	740	.68
450 CFM/TON	OFF	OFF	ON	OFF	2165	665	.62	2170	725	.67	2150	820	.76	2150	830	.77	2150	855	.79	---	---	---

① - WET COIL, NO FILTERS

② - FACTORY SETTINGS

Static Pressure Drop Through Electric Heaters

	NUMBER OF RACKS		
	1	2	3
AIRFLOW CFM	AIR PRESSURE DROP inches of w.g.		
600	0.02	0.04	0.06
700	0.03	0.05	0.07
800	0.03	0.06	0.09
900	0.04	0.08	0.12
1000	0.05	0.10	0.15
1100	0.06	0.12	0.18
1200	0.07	0.14	0.21
1300	0.08	0.17	0.25
1400	0.10	0.20	0.30
1500	0.12	0.23	0.35

Electric Heater Racks

HEATER MODEL NO.	NO. OF RACKS
BAYHTRC106A	1
BAYHTRC109A	1
BAYHTRC110A	1
BAYHTRC111A	1
BAYHTRC117A	2



Electric Heater Data

Supplementary Heaters

Unit Model No.	Capacity at 208V		Capacity at 240V		Rated Voltage	No. of Circuits	Amps Per Circuit at 208V	Amps Per Circuit at 240V	Ordering Model Number
	Kw	Btuh	Kw	Btuh					
WCH024C1	4.33	14800	5.76	19600	208/240/1/60	1	20.8	24	BAYHTRC106A
	7.93	27000	10.56	36000	208/240/1/60	1	38.1	44	BAYHTRC111A
WCH030C1,036C1,042C1	4.33	14800	5.76	19600	208/240/1/60	1	21.0	24	BAYHTRC106A
	6.12	20900	8.16	27800	208/240/1/60	1	29.4	34.0	BAYHTRC109A ③
	7.93	27000	10.56	36000	208/240/1/60	1	38.1	44	BAYHTRC111
	12.98	44300	17.28	59000	208/240/1/60	1	62.4	72	BAYHTRC117A ①
WCH048F1 ②	4.33	14800	5.76	19600	208/240/1/60	1	21.0	24	BAYHTRC106A
	6.12	20900	8.16	27800	208/240/1/60	1	29.4	34.0	BAYHTRC109A ③
	7.93	27000	10.56	36000	208/240/1/60	1	38.1	44	BAYHTRC110A ②
	12.98	44300	17.28	59000	208/240/1/60	1	62.4	72	BAYHTRC117A ①
WCH060F1	4.33	14800	5.76	19600	208/240/1/60	1	21.0	24	BAYHTRC106A
	6.12	20900	8.16	27800	208/240/1/60	1	29.4	34.0	BAYHTRC109A ③
	7.93	27000	10.56	36000	208/240/1/60	1	38.1	44	BAYHTRC111A
	12.98	44300	17.28	59000	208/240/1/60	1	62.4	72	BAYHTRC117A ①

NOTE:
 ① Heater has a fuse box factory provided.
 ② BAYHTRC110A is used only in the WCH048F1.
 ③ BAYHTRC109A is used only in the WCH036-042C1 and WCH048-060F1 models.

Field Installed Control Options

Thermostats

Two stages heating/cooling or one stage heating/cooling thermostats are available in either manual or automatic changeover.

Programmable Electronic Night Setback Thermostat

Heating setback and cooling setup with 7-day, 5-1-1 programming capability. Available in two heating/cooling or one heating/cooling versions with automatic changeover.

Supplemental Electric Heater

Heater module mounts in unit discharge air passage. Each heater assembly includes automatically resetting heat limit switches for thermal protection. A polarized plug provides connection to unit low voltage control wiring.

Low Ambient Control Kit

Provides low ambient cooling operation to 0° F.

Hook Up Diagram

WCH024-060 Units (With Supplementary Heaters)

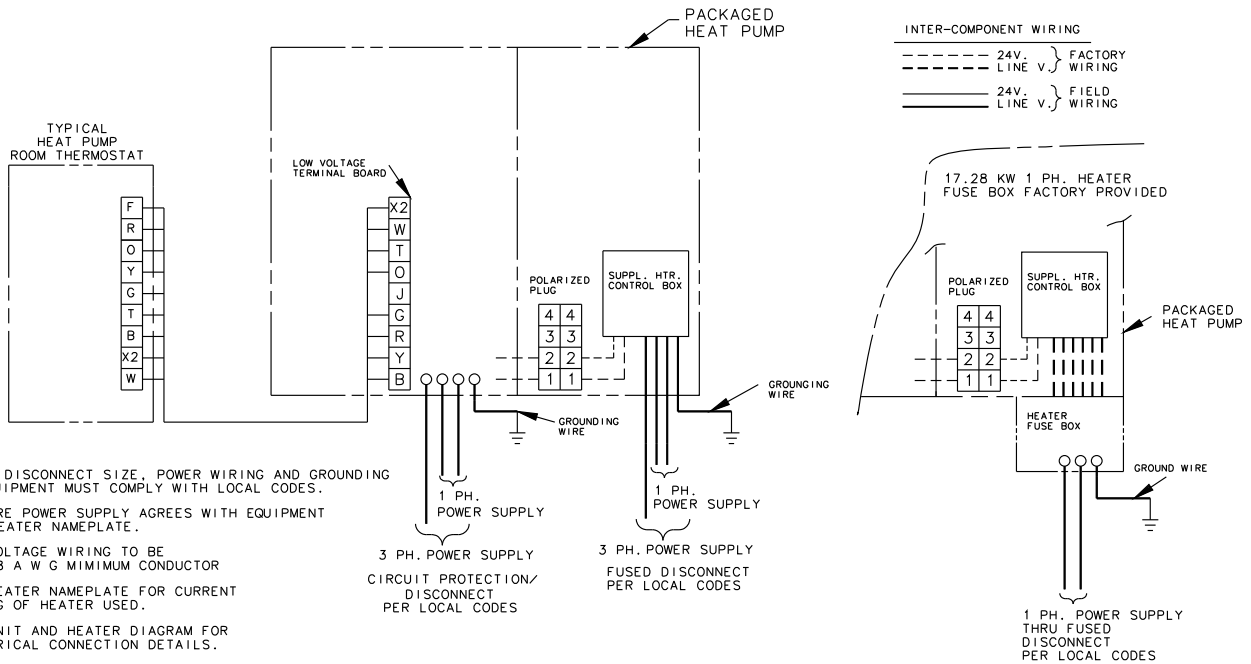

From Dwg. 21B756671 Rev. 2

WCH024-060 Units (Without Supplementary Heaters)

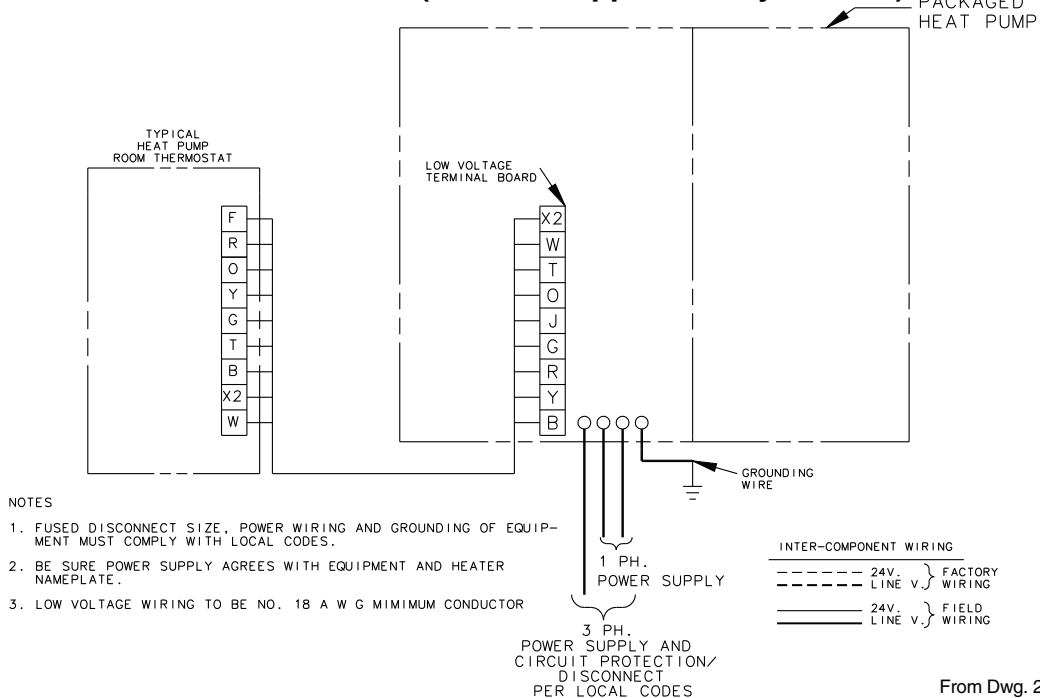

From Dwg. 21B756743 Rev. 1

Typical Wiring

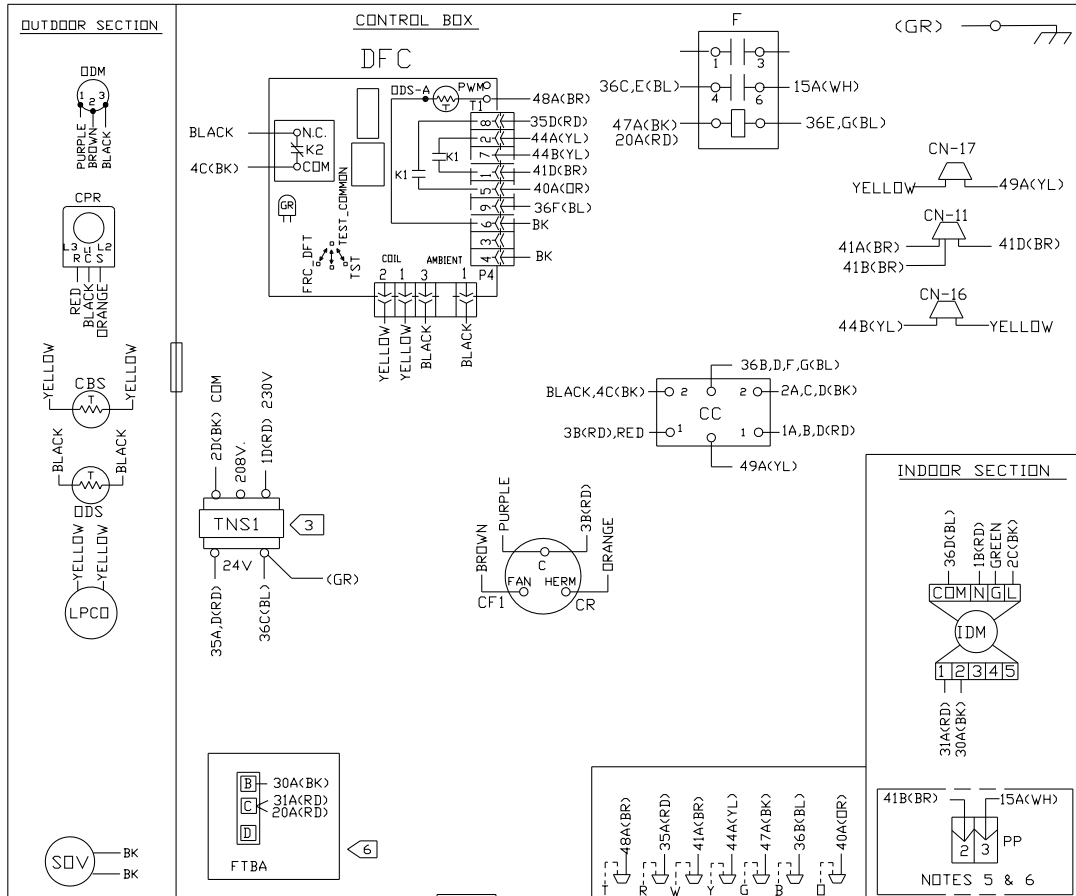

1. CONNECTIONS SHOWN ARE FOR A TYPICAL MECHANICAL THERMOSTAT. SEE SCHEMATIC SUPPLIED WITH THERMOSTAT FOR PROPER CONNECTIONS. LOW VOLTAGE WIRING TO UNIT MAY BE NEC CLASS 2 AND MUST BE A MIN. OF 18 A.W.G..
2. MAXIMUM ADDITIONAL EXTERNAL LOAD (PILOT DUTY) BETWEEN "B" AND "R" OF 0.5 AMPS, 24 VAC IS AVAILABLE WHEN A HEATER IS INSTALLED.
3. FOR 208 VOLT OPERATION, MAKE THE FOLLOWING WIRING CHANGES:
AT THE TNS1 REMOVE 1D(RD) WIRE AND CONNECT TO THE 208V TERMINAL ON THE TRANSFORMER.
4. IF ANY OF THE ORIGINAL WIRE AS SUPPLIED IN THIS UNIT MUST BE REPLACED, REPLACE IT WITH APPLIANCE WIRING MATERIAL RATED AT 105 C.
5. APPROVED SUPPLEMENTARY HEATERS FOR FIELD INSTALLATION IN UNIT.
6. SEE OPTIONAL HEATER ACCESSORY DIAGRAM FOR DETAILS OF HEATER WIRING.
7. DASHED LINES INDICATE RECOMMENDED FIELD WIRING.

MODELS
WCH030C1
WCH036C1

DEVICE	DESCRIPTION	LINE
AH	ELECTRIC HEAT CONTACTOR COIL	48
CBS	COIL BOTTOM SENSOR	37
CC	COMPRESSOR CONTACTOR COIL	50-51
CF1	OUTDOOR FAN CAPACITOR	17
CN	CONNECTOR OR WIRE NUT	
CPR	COMPRESSOR	14-17
CR	COMPRESSOR RUN CAPACITOR	16
DFC	DEFROST CONTROL BOARD	27-38
F	FAN RELAY	45
FTBA	FAN TERMINAL BLOCK	42,43
IDM	INDOOR FAN MOTOR	21-23
IDL	INTERNAL OVERLOAD	
LPCD	LOW PRESSURE CUTOUT	51
ODM	OUTDOOR FAN MOTOR	18-20
ODS	OUTDOOR AMBIENT SENSOR	34
PP	POLARIZED PLUG	48-49
TNS1	CONTROL POWER TRANSFORMER	26
TDL	DISCHARGE LINE THERMOSTAT	20

WIRE COLOR DESIGNATION			
ABBR	COLOR	ABBR	COLOR
BK	BLACK	PR	PURPLE
BL	BLUE	RD	RED
BR	BROWN	WH	WHITE
GR	GREEN	YL	YELLOW
OR	ORANGE		

Typical Wiring Diagram
For Specific Wiring see individual Service Facts

D757578P02

(continued on next page)



Typical Wiring

1 — CAUTION—NOT SUITABLE FOR USE ON SYSTEMS EXCEEDING 150 VOLTS TO GROUND.
 2 — ATTENTION: NE CONVIENT PAS POUR LES INSTALLATIONS DE PLUS DE 150V. A TERRE.
 3 —
 4 — UNIT FACTORY WIRED FOR 230V
 5 — SEE WIRING DIAGRAM NOTES FOR REQUIRED WIRING CHANGES WHEN INSTALLED ON A 208V POWER SUPPLY.
 6 —
 7 —

WARNING
 HAZARDOUS VOLTAGE!
 DISCONNECT ALL ELECTRIC POWER INCLUDING REMOTE DISCONNECTS BEFORE SERVICING.
 FAILURE TO DISCONNECT POWER SUPPLY BEFORE SERVICING CAN CAUSE SEVERE PERSONAL INJURY OR DEATH.

AVERTISSEMENT
 VOLTAGE HASARDEUX!
 DECONNECTEZ TOUTES LES SOURCES ELECTRIQUES INCLUANT LES DISJONCTEURS SITUES A DISTANCE AVANT D'EFFECTUER L'ENTRETIEN. FAUTE DE DECONNECTER LA SOURCE ELECTRIQUE AVANT D'EFFECTUER L'ENTRETIEN PEUT ENTRAINER DES BLESSURES CORPORELLES SEVERES OU LA MORT.

CAUTION
 USE COPPER CONDUCTORS ONLY!
 UNIT TERMINALS ARE NOT DESIGNED TO ACCEPT OTHER TYPES OF CONDUCTORS. FAILURE TO DO SO MAY CAUSE DAMAGE TO THE EQUIPMENT.

8 — POWER SUPPLY PER LOCAL CODES
 9 — SEE NAMEPLATE FOR LINE VOLTAGE.

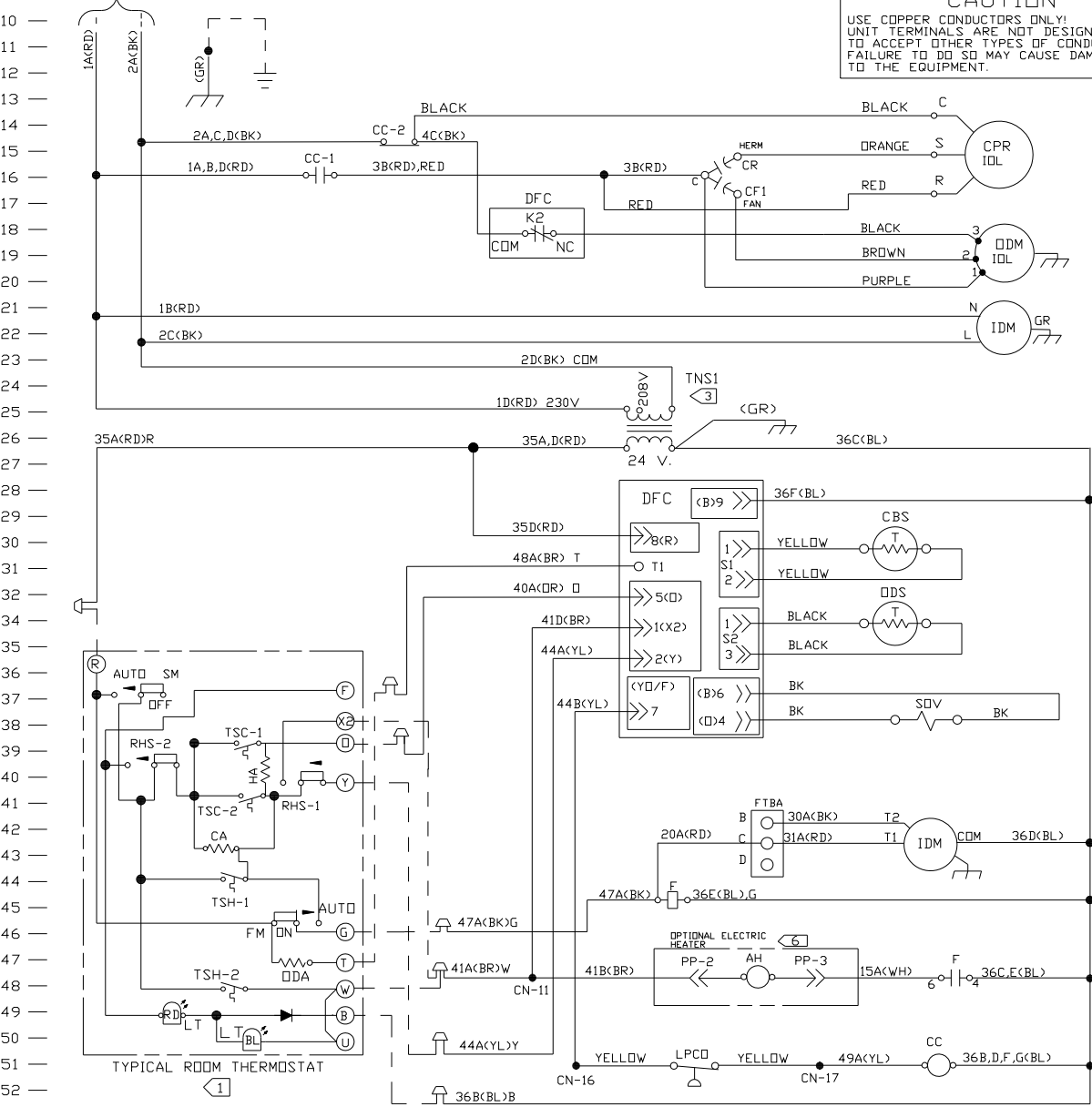



Dimensions

WCH024-042C OUTLINE DRAWING

NOTE: ALL DIMENSIONS ARE IN MM (INCHES)

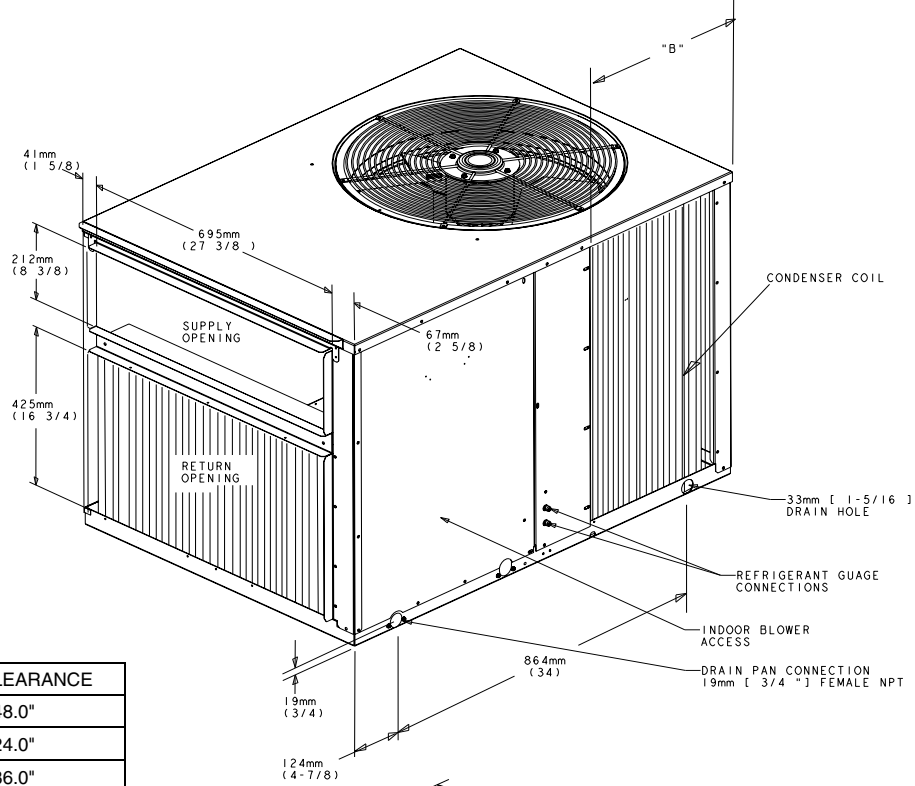

INSTALLATION / SERVICE CLEARANCE	
BACK	48.0"
LEFT SIDE	24.0"
RIGHT SIDE	36.0"
TOP	36.0"

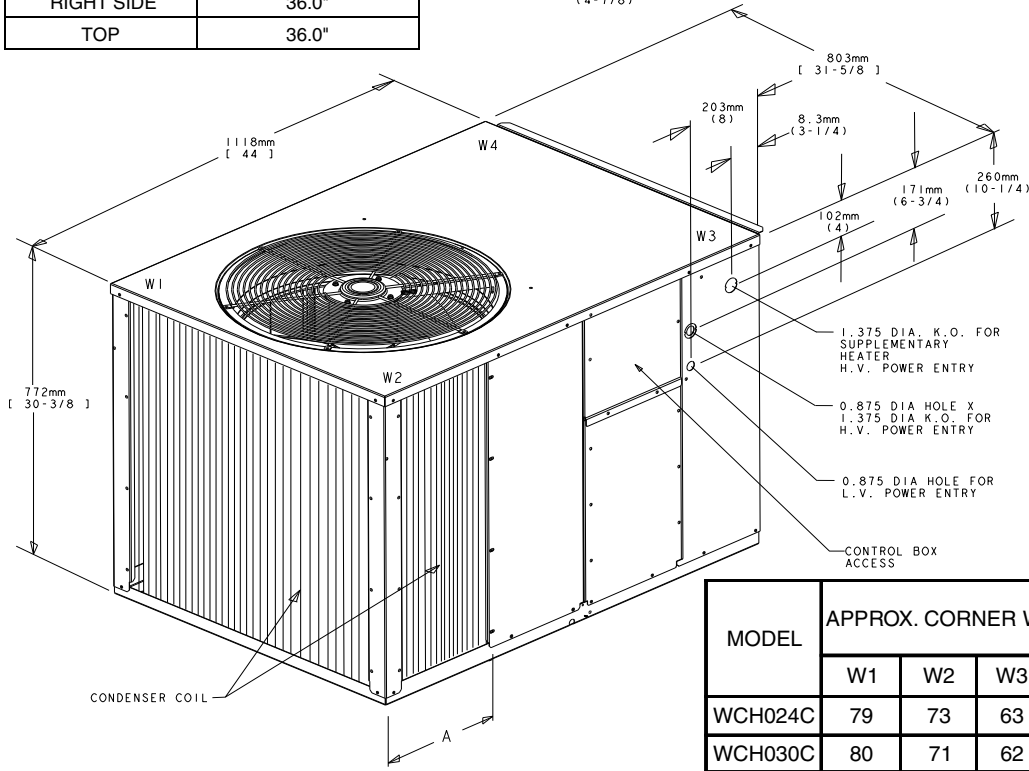

MODEL	APPROX. CORNER WTS / LBS.				TOTAL WEIGHT LBS.	COIL DIMENSION (in)	
	W1	W2	W3	W4		A	B
WCH024C	79	73	63	68	282	14	16
WCH030C	80	71	62	70	284	14	16
WCH036C	83	75	66	73	297	14	16
WCH042C	84	79	72	77	312	20	16



Dimensions

WCH048-060F OUTLINE DRAWING

NOTE: ALL DIMENSIONS ARE IN MM (INCHES)

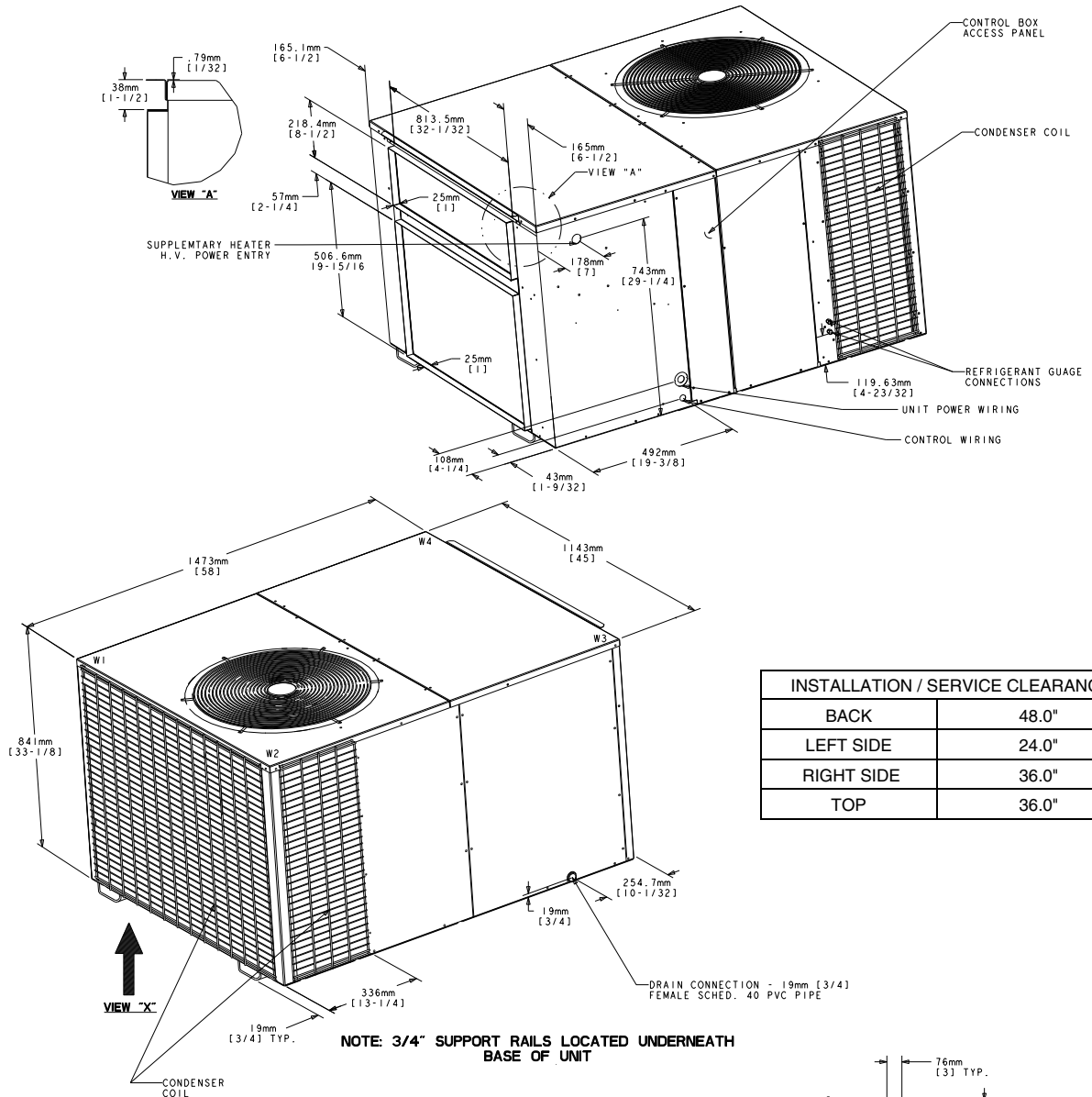

INSTALLATION / SERVICE CLEARANCE	
BACK	48.0"
LEFT SIDE	24.0"
RIGHT SIDE	36.0"
TOP	36.0"

NOTE: 3/4" SUPPORT RAILS LOCATED UNDERNEATH BASE OF UNIT

MODEL	APPROX. CORNER WTS - LBS.				TOTAL WEIGHT LBS.
	W1	W2	W3	W4	
WCH048F	128	128	97	97	447
WCH060F	115	115	114	114	457



Mechanical Specifications/Options

General

All units are factory assembled, piped, internally wired and fully charged with R-22. Units are UL listed and carry a UL label. All units are factory run-tested to check cooling and heating operation, defrost operation, fan and blower rotation and control sequence. Units shall be designed to operate at ambient temperatures between 115° F. and 45° F. in cooling mode (as shipped) and between 75° F. and -20° F. in heating mode. Cooling and heating performances are rated in accordance with ARI standards. Units are designed for either rooftop or ground level installation.

Unit Casing

All components are mounted in a weather-resistant steel cabinet with a baked-on enamel finish. Access panels are provided for unit controls, indoor coil and supply air fan. Top cover (includes outdoor fan) shall be removable for access or installation of electric heaters and outdoor fan and compressor. Indoor air section is completely insulated with fireproof, permanent, odorless glass fiber material. Knockouts are provided for utility and control connections. Drain connections are provided to accommodate indoor coil water runoff. Coil guards are provided for the protection of the outdoor coil.

Compressor

Hermetically sealed, high efficiency Climatuff® compressor designed for heat pump duty. Internal line break over current and over temperature protection, high and low pressure protection.

Refrigerant Circuit

All units have thermostatic expansion valve refrigerant control for both heating and cooling operation. Service pressure tap ports, check valves, solenoid-operated reversing valve, and refrigerant line filter driers are standard.

Indoor and Outdoor Coil

Indoor and outdoor coils are constructed of aluminum plate fins mechanically bonded to seamless copper tubing.

Outdoor Fan

One, direct-drive, statically and dynamically balanced propeller fan is used in top discharge configuration. Permanently lubricated weatherproof motors have built-in thermal overload protection.

Indoor Fan

Forward-curved, centrifugal-type fan with multi-speed, direct-drive motor. Motor shall be permanently lubricated and has built-in overload protection.

Demand Defrost Control

The electronic demand defrost control measures outdoor ambient and outdoor coil conditions and eliminates unnecessary defrost cycles.

Accessories

Supplemental Electric Heater — Heater module shall mount in unit discharge air passage. Each heater assembly includes automatically resetting heat limit switches for thermal protection. A polarized plug provides connection to unit low voltage control wiring.

Indoor Thermostat — Two-stage heating, one-stage cooling thermostat is available in either manual or automatic changeover. Thermostat provides automatic or continuous fan operation and includes outdoor thermistor, emergency heat switch with indicator light, and auxiliary heat indicator light.

Low Ambient Control Kit — Provides low ambient cooling operation to 0° F.