

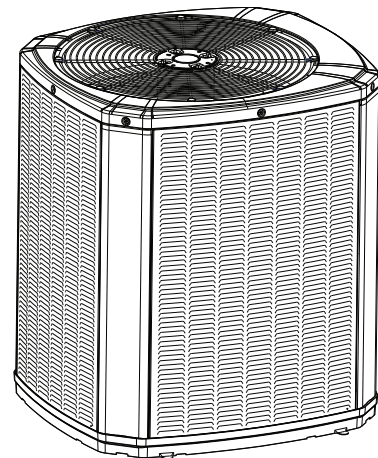

Product and Submittal Data

18 TruComfort™ Variable Speed Air Conditioners

5TTV8X24A1000A/B
5TTV8X36A1000A/B
5TTV8X48A1000A/B
5TTV8X60A1000A/B



*Note: Graphics in this document are for representation only.
Actual model may differ in appearance.*



Introduction

Copyright

This document and the information in it are the property of Trane, and may not be used or reproduced in whole or in part without written permission. Trane reserves the right to revise this publication at any time, and to make changes to its content without obligation to notify any person of such revision or change.

Trademark

All trademarks referenced in this document are the trademarks of their respective owners.

Revision History

- Updated the tables in Product Specifications chapter.
- Updated the wiring diagram.

Diagnostics Mobile App



The Diagnostics Mobile App is available by scanning a QR code above, the one located inside this unit or by searching for the Trane or American Standard Diagnostics App in your App Store®. This system must include a A/T HUI2360A200U thermostat and a TSYS2C60A2VVU system controller to operate and is Link communicating only.



Table of Contents

Model Number Description	4
General Data	5
Product Specifications	6
Sound Data.....	9
Wiring Diagram	10
Dimensional Data.....	11
Mechanical Specification Options.....	12



Model Number Description

Outdoor Units

Digit 1 — Refrigerant Type

5 = R-454B

Digit 2 — Brand

T = Trane

Digit 3 — System Type

C = Cold Climate Heat Pump

T = AC

W = HP

Digit 4 — Product Family

A = Light Commercial

B = XB

R = Wire Top Grille

V = VSPD

X = WeatherGuard Top

Digit 5 — Nominal Rated SEER2

0 = 20 SEER2

3 = 13 SEER2

4 = 14 SEER2

5 = 15 SEER2

6 = 16 SEER2

7 = 17 SEER2

8 = 18 SEER2

Digit 6 — Field Connection

0 = Brazed

5 = Mechanical

X = Link™

Digit 7, 8 — Nominal Tonnage

12 = 1.0

18 = 1.5

19 = 1.5

24 = 2.0

25 = 2.0

30 = 2.5

31 = 2.5

36 = 3.0

37 = 3.0

42 = 3.5

43 = 3.5

48 = 4.0

49 = 4.0

60 = 5.0

61 = 5.0

72 = 6.0

Digit 9 — Major Design Change

A Thru Z Mode = No F, I, 0

Digit 10 — Power Supply (Voltage/Ph/Hz)

1 = 200-208-230/1/60

3 = 200-230/3/60

4 = 460/3/60

5 = 400/3/60

A = 220-240/1/50

D = 380-415/3/50

Digit 11, 12, 13 — Other Functions

000 = Typical-no meaning

Digit 14 — Minor Design Change

A Thru Z Mode = No F, I, 0

Digit 15 — Service Digit - Not Orderable

A Thru Z Mode = No F, I, 0



General Data

AHRI standard 210/240 rating conditions:

- Cooling: 80°F DB; air entering indoor coil: 67°F WB; air entering outdoor coil: 95°F DB
- High temperature heating: 47°F DB; air entering outdoor coil: 43°F WB; entering indoor coil: 70°F DB
- Low temperature heating: 17°F DB; air entering outdoor coil: 15°F WB; air entering indoor coil: 70°F DB
- Rated indoor airflow for heating is the same as for cooling.

AHRI standard 270 rating conditions:

The noise rating numbers are determined with the unit in cooling operation. Standard Noise Rating number is at 95°F outdoor air.



Product Specifications

Table 1. Models 5TTV8X24A1000A, 5TTV8X24A1000B, 5TTV8X36A1000A, and 5TTV8X36A1000B

Outdoor Unit ^{(a) (b)}	5TTV8X24A1000A	5TTV8X24A1000B	5TTV8X36A1000A	5TTV8X36A1000B
Power Conns. – V/Ph/Hz ^(c)	208/230/1/60	208/230/1/60	208/230/1/60	208/230/1/60
Min. Brch. Cir. Ampacity	19.0	20.0	27.0	29.0
Br. Cir. Prot. Rtg. – Rec/Max. (Amps)	20/30	20/30	30/40	30/40
Compressor	Rotary	Rotary	Rotary	Rotary
No. Used – No. Speeds	1 – Variable	1 – Variable	1 – Variable	1 – Variable
MRC	17.8	17.8	27.1	27.1
Factory Installed				
Start Components ^(d)	No	No	No	No
Insulation/Sound Blanket	Yes	Yes	Yes	Yes
Compressor Heat	Yes	Yes	Yes	Yes
Outdoor Fan				
Dia. (in.) – No. Used	23 – 1	23 – 1	23 – 1	23 – 1
Type Drive – No. Speeds	Direct – Variable	Direct – Variable	Direct – Variable	Direct – Variable
No. Motors – Hp	1 – 1/3	1 – 1/3	1 – 1/3	1 – 1/3
Motor Speed R.P.M.	200 – 1200	200 – 1200	200 – 1200	200 – 1200
Volts/Ph/Hz	245 – 385/3/60	245 – 385/3/60	245 – 385/3/60	245 – 385/3/60
MOC	1.5	1.5	1.5	1.5
Outdoor Coil – Type	Spine Fin™	Spine Fin™	Spine Fin™	Spine Fin™
Rows – F.P.I.	1 – 24	1 – 24	1 – 24	1 – 24
Face Area (Sq. Ft.)	19.77	19.77	19.77	19.77
Tube Size (in.)	3/8	3/8	3/8	3/8
Refrigerant	R-454B	R-454B	R-454B	R-454B
Lbs. – R-454B (O.D. Unit) ^(e)	6 LB – 8 OZ	6 LB – 8 OZ	6 LB – 7 OZ	6 LB – 7 OZ
Factory Supplied	Yes	Yes	Yes	Yes
Rated Line Size – in. O.D. Gas ^(f)	1/2	1/2	5/8	5/8
Rated Line Size – in. O.D. Liq. ^(f)	5/16	5/16	5/16	5/16
Charging Specifications				
Subcooling (°F)	10	10	10	10
Dimensions	H x W x D	H x W x D	H x W x D	H x W x D
Crated (in.)	46 x 30 x 33	46 x 30 x 33	46 x 30 x 33	46 x 30 x 33
Weight				
Shipping (lbs.)	197	197	210	210
Net (lbs.)	176	176	189	189
Optional Accessories				

Table 1. Models 5TTV8X24A1000A, 5TTV8X24A1000B, 5TTV8X36A1000A, and 5TTV8X36A1000B (continued)

Outdoor Unit ^{(a) (b)}	5TTV8X24A1000A	5TTV8X24A1000B	5TTV8X36A1000A	5TTV8X36A1000B
GFCI Kit	TR02LGFCI25	TR02LGFCI25	TR02LGFCI30	TR02LGFCI30
Rubber Isolator Kit	BAYISLT101	BAYISLT101	BAYISLT101	BAYISLT101
Snow Leg – Base and Cap 4-in. High	BAYLEGS002	BAYLEGS002	BAYLEGS002	BAYLEGS002
Snow Leg – 4-in. Extension	BAYLEGS003	BAYLEGS003	BAYLEGS003	BAYLEGS003
SmartCharge™ Tool	BAYCAKT002	BAYCAKT002	BAYCAKT002	BAYCAKT002
Extreme Condition Mounting Kit	BAYECMT023	BAYECMT023	BAYECMT023	BAYECMT023
Refrigerant Lineset ^(g)	—			

^(a) Certified in accordance with the Unitary Air-conditioner equipment certification program which is based on AHRI standard 210/240.

^(b) Rated in accordance with AHRI standard 270/275.

^(c) Calculated in accordance with N.E.C. Only use HACR circuit breakers or fuses.

^(d) No means no start components. Yes means quick start kit components. PTC means positive temperature coefficient starter. Optional kit shown.

^(e) This value approximate. For more precise value see unit nameplate.

^(f) Reference the outdoor unit ship-with literature for refrigerant piping length and lift guidelines. Reference the refrigerant piping software pub # 32-3312-xx or *Refrigerant Piping Manual for Small Split Cooling and Heat Pump Systems Application Guide* (SS-APG006*-EN) for long line sets or specialty applications (xx denotes latest revision).

^(g) 25, 30, 35 and 50 foot linesets available. For a complete listing of lineset options available from equipment or supply stores, refer to the Trane Residential and Light Commercial Product Handbook.

Table 2. Models 5TTV8X48A1000A, 5TTV8X48A1000B, 5TTV8X60A1000A, and 5TTV8X60A1000B

Outdoor Unit ^{(a) (b)}	5TTV8X48A1000A	5TTV8X48A1000B	5TTV8X60A1000A	5TTV8X60A1000B
Power Conns. – V/Ph/Hz ^(c)	208/230/1/60	208/230/1/60	208/230/1/60	208/230/1/60
Min. Brch. Cir. Ampacity	36.0	34.0	43.0	40.0
Br. Cir. Prot. Rtg. – Rec/Max. (Amps)	40/50	40/50	50/60	40/60
Compressor	Rotary	Rotary	Rotary	Rotary
No. Used – No. Speeds	1 – Variable	1 – Variable	1 – Variable	1 – Variable
MRC	39.2	39.2	46.1	46.1
Factory Installed				
Start Components ^(d)	No	No	No	No
Insulation/Sound Blanket	Yes	Yes	Yes	Yes
Compressor Heat	Yes	Yes	Yes	Yes
Outdoor Fan				
Dia. (in.) – No. Used	27.5 – 1	27.5 – 1	27.5 – 1	27.5 – 1
Type Drive – No. Speeds	Direct – Variable	Direct – Variable	Direct – Variable	Direct – Variable
No. Motors – Hp	1 – 1/2	1 – 1/2	1 – 1/2	1 – 1/2
Motor Speed R.P.M.	200 – 1200	200 – 1200	200 – 1200	200 – 1200
Volts/Ph/Hz	245 – 385/3/60	245 – 385/3/60	245 – 385/3/60	245 – 385/3/60
MOC	2.3	2.3	2.3	2.3
Outdoor Coil – Type	Spine Fin™	Spine Fin™	Spine Fin™	Spine Fin™
Rows – F.P.I.	1 – 24	1 – 24	1 – 24	1 – 24
Face Area (Sq. Ft.)	27.87	27.87	27.87	27.87
Tube Size (in.)	3/8	3/8	3/8	3/8
Refrigerant	R-454B	R-454B	R-454B	R-454B



Product Specifications

Table 2. Models 5TTV8X48A1000A, 5TTV8X48A1000B, 5TTV8X60A1000A, and 5TTV8X60A1000B (continued)

Outdoor Unit ^(a) ^(b)	5TTV8X48A1000A	5TTV8X48A1000B	5TTV8X60A1000A	5TTV8X60A1000B
Lbs. – R-454B (O.D. Unit) ^(e)	9 LB – 7 OZ	9 LB – 7 OZ	9 LB – 10 OZ	9 LB – 10 OZ
Factory Supplied	Yes	Yes	Yes	Yes
Rated Line Size – in. O.D. Gas ^(f)	3/4	3/4	3/4	3/4
Rated Line Size – in. O.D. Liq. ^(f)	5/16	5/16	5/16	5/16
Charging Specifications				
Subcooling (°F)	10	10	10	10
Dimensions				
Crated (in.)	46 x 35 x 38	46 x 35 x 38	46 x 35 x 38	46 x 35 x 38
Weight				
Shipping (lbs.)	251	251	261	261
Net (lbs.)	226	226	236	236
Optional Accessories				
GFCI Kit	TR04LGFCI40	TR04LGFCI40	TR04LGFCI40	TR04LGFCI40
Rubber Isolator Kit	BAYISLT101	BAYISLT101	BAYISLT101	BAYISLT101
Snow Leg – Base and Cap 4-in. High	BAYLEGS002	BAYLEGS002	BAYLEGS002	BAYLEGS002
Snow Leg – 4-in. Extension	BAYLEGS003	BAYLEGS003	BAYLEGS003	BAYLEGS003
SmartCharge™ Tool	BAYCAKT002	BAYCAKT002	BAYCAKT002	BAYCAKT002
Extreme Condition Mounting Kit	BAYECMT023	BAYECMT023	BAYECMT023	BAYECMT023
Refrigerant Lineset ^(g)	–			

^(a) Certified in accordance with the Unitary Air-conditioner equipment certification program which is based on AHRI standard 210/240.

^(b) Rated in accordance with AHRI standard 270/275.

^(c) Calculated in accordance with N.E.C. Only use HACR circuit breakers or fuses.

^(d) No means no start components. Yes means quick start kit components. PTC means positive temperature coefficient starter. Optional kit shown.

^(e) This value approximate. For more precise value see unit nameplate.

^(f) Reference the outdoor unit ship-with literature for refrigerant piping length and lift guidelines. Reference the refrigerant piping software pub # 32-3312-xx or *Refrigerant Piping Manual for Small Split Cooling and Heat Pump Systems Application Guide* (SS-APG006*-EN) for long line sets or specialty applications (xx denotes latest revision).

^(g) 25, 30, 35 and 50 foot linesets available. For a complete listing of lineset options available from equipment or supply stores, refer to the Trane Residential and Light Commercial Product Handbook.



Sound Data

Table 3. Models 5TTV8X24A, 5TTV8X36A, 5TTV8X48A, and 5TTV8X60A

Model	Mode	Speed	A-Weighted Sound Power Level [dB (A)]	Full Octave Sound Power [dB]							
				63 Hz	125 Hz	250 Hz	500 Hz	1000 Hz	2000 Hz	4000 Hz	8000 Hz
5TTV8X24A	Cool	Min	55	67.2	51.8	55.0	55.3	47.6	40.1	37.2	36.7
	Cool	Max	67	72.5	65.6	62.5	67.4	62.5	53.5	50.0	45.4
5TTV8X36A	Cool	Min	58	68.3	58.0	59.3	54.6	53.0	48.0	43.7	41.9
	Cool	Max	74	73.5	75.0	70.2	74.1	68.1	61.7	59.7	52.8
5TTV8X48A	Cool	Min	59	68.6	56.3	65.3	53.6	50.7	45.1	37.3	37.4
	Cool	Max	74	83.9	76.7	73.2	72.7	69.0	64.2	59.2	50.3
5TTV8X60A	Cool	Min	66	64.5	57.8	67.7	64.9	62.7	50.4	41.5	42.7
	Cool	Max	76	77.0	80.8	76.0	75.3	70.1	64.0	62.3	54.7

Note: Rated in accordance with AHRI Standard 270.



Dimensional Data

Figure 2. Dimensional drawing

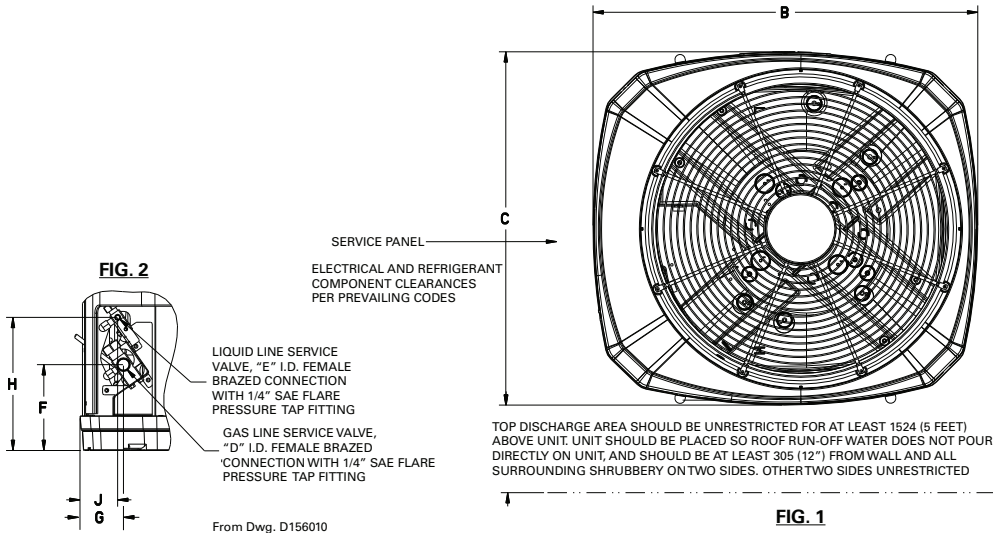

From Dwg. D156010

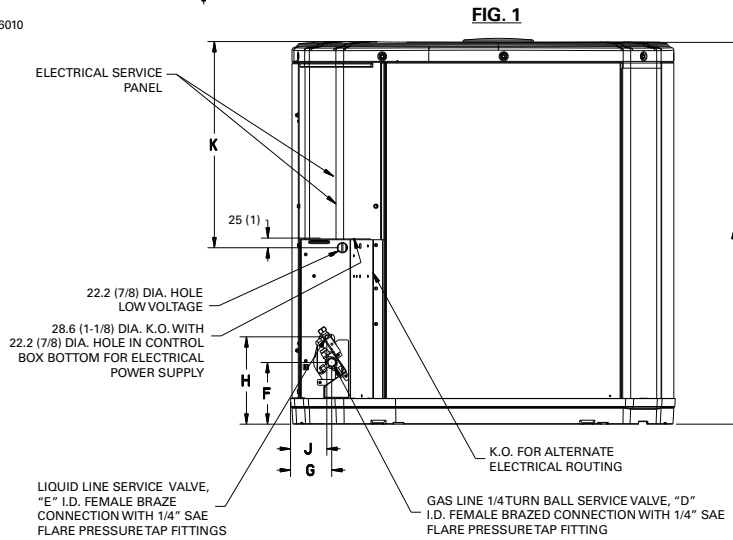

Table 4. Dimensions (inch)

Model	Base	A	B	C	D	E	F	G	H	J	K
5TTV8X24A	3	1035 (40-3/4)	829 (32-5/8)	756 (29-3/4)	13-1/2	8-5/16	127 (5)	76 (3)	197 (7-3/4)	57 (2-1/4)	813 (32)
5TTV8X36A	3	1035 (40-3/4)	829 (32-5/8)	756 (29-3/4)	16-5/8	8-5/16	127 (5)	76 (3)	197 (7-3/4)	57 (2-1/4)	813 (32)
5TTV8X48A	4	1045 (41-1/8)	946 (37-1/4)	870 (34-1/4)	19-3/4	8-5/16	127 (5)	76 (3)	197 (7-3/4)	57 (2-1/4)	813 (32)
5TTV8X60A	4	1147 (45-1/8)	946 (37-1/4)	870 (34-1/4)	19-3/4	8-5/16	127 (5)	76 (3)	197 (7-3/4)	57 (2-1/4)	813 (32)



Mechanical Specification Options

General

This unit is designed to operate at outdoor ambient temperatures from 55° F to 120° F in cooling. From — 0° F to 66° F in heating (heat pumps only). Only AHRI approved indoor matches are approved for use with these models.

Trane Link Air Conditioners

This outdoor unit contains the Trane Link Air Conditioners digital communication with Plug-n-Play set up.

Casing

Unit casing is constructed of heavy gauge, G60 galvanized steel and painted with a weather-resistant powder paint on all louvered panels and prepaint on all other panels. Corrosion and weatherproof CMBP-G30 DuraTuff™ base.

Refrigerant Controls

Refrigeration system controls include condenser fan, compressor inverter drive and high and low pressure switches. A factory supplied, field installed filter is standard.

Compressor

Inverter driven compressor with variable output capacities. Noise enclosure minimizes sound levels. Compressor protections reduce operating speed and current draw to maintain operation while protecting the compressor.

Condenser Coil

The Spine Fin™ outdoor coil provides low airflow resistance and efficient heat transfer. The coil is protected on all four sides by louvered panels.

Low Ambient Cooling

As manufactured, this system has built in freeze protection that will allow cooling operation below 55°F but will reduce capacity or shut down completely to prevent operation under adverse conditions.

Comfort Control

This system must include a A/T HUI2360A200U thermostat and a TSYS2C60A2VVU system controller to operate and is Link communicating only.



Trane - by Trane Technologies (NYSE: TT), a global innovator - creates comfortable, energy efficient indoor environments for commercial and residential applications. For more information, please visit trane.com or tranetechnologies.com.



The AHRI Certified mark indicates Trane U.S. Inc. participation in the AHRI Certification program. For verification of individual certified products, go to ahridirectory.org.

Trane has a policy of continuous data improvement and it reserves the right to change design and specifications without notice. We are committed to using environmentally conscious print practices.