

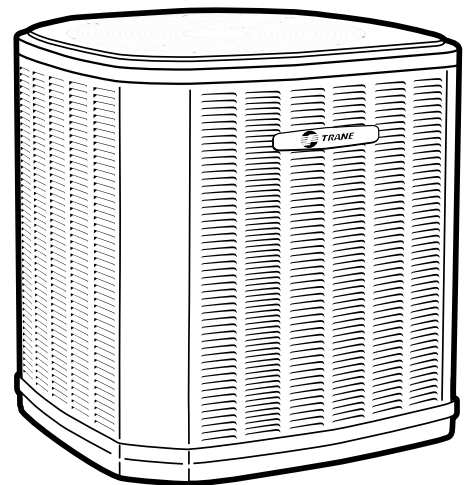

# Product Data

## Split System Cooling

5TTR4018A1000A  
5TTR4024A1000A  
5TTR4030A1000A/B  
5TTR4036A1000A/B  
5TTR4042A1000A  
5TTR4048A1000A/B  
5TTR4060A1000A/B



*Note: "Graphics in this document are for representation only. Actual model may differ in appearance."*



# Product Specifications

Model No. <sup>(a)</sup>	5TTR4018A1000A	5TTR4024A1000A	5TTR4030A1000A/B	5TTR4036A1000A/B
POWER CONNS. - V/PH/HZ <sup>(b)</sup>	208/230/1/60	208/230/1/60	208/230/1/60	208/230/1/60
MIN. BRCH. CIR. AMPACITY	9	14	15/17	18
BR. CIR. PROT. RTG. - MAX. (AMPS)	20	25	25	30
COMPRESSOR	CLIMATUFF® - SCROLL	CLIMATUFF® - SCROLL	CLIMATUFF® - SCROLL	CLIMATUFF® - SCROLL
RL AMPS - LR AMPS	6.9 - 45	10.3 - 60	12.5 - 67 / 12.7 - 76	13.5 - 75 / 13.5 - 83
Outdoor Fan FL AMPS	0.71	0.71	0.64	0.64
Fan HP	1/8	1/8	1/8	1/8
Fan Dia (inches)	23	23	23	23
Coil	SPINE FIN™	SPINE FIN™	SPINE FIN™	SPINE FIN™
Refrigerant R-454B	3 LBS., 12 OZ	3 LBS., 10 OZ	3 LBS., 8 OZ	3 LBS., 8 OZ
VALVE CONNECTION SIZE - IN. O.D. GAS	3/4	3/4	3/4	3/4
VALVE CONNECTION SIZE - IN. O.D. LIQ	5/16	5/16	5/16	5/16
LINE SIZE - IN. O.D. GAS <sup>(c)</sup>	3/4	3/4	3/4	7/8
LINE SIZE - IN. O.D. LIQ.	5/16	5/16	5/16	5/16
Charge Spec. Subcooling	10°F	10°F	10°F	10°F
Dimensions H x W X D Crated (IN.)	42 x 30 x 33	38 x 30 x 33	42 x 30 x 33	38 x 30 x 33
Weight - Shipping (lbs.)	220	183	220	183
Weight - Net (lbs.)	184	156	184	156
<b>Optional Accessories:</b>				
Anti-short Cycle Timer	TAYASCT501A	TAYASCT501A	TAYASCT501A	TAYASCT501A
Evaporator Defrost Control	AY28X079	AY28X079	AY28X079	AY28X079
Rubber Isolator Kit	BAYISLT101	BAYISLT101	BAYISLT101	BAYISLT101
Extreme Condition Mount Kit	BAYECMT023	BAYECMT023	BAYECMT023	BAYECMT023
Start Kit	BAYKSKT263	BAYKSKT263	BAYKSKT263	BAYKSKT263
Crankcase Heater Kit	BAYCCHT302	BAYCCHT302	BAYCCHT302	BAYCCHT302
Seacoast Kit	BAYSEAC001	BAYSEAC001	BAYSEAC001	BAYSEAC001
Low Ambient Kit	BAYLOAM103	BAYLOAM103	BAYLOAM103	BAYLOAM103
Service Valve Panel Cover	TAYSVPANL0032AA	TAYSVPANL0032AA	TAYSVPANL0044AA	TAYSVPANL0044AA
Refrigerant Lineset <sup>(d)</sup>				

<sup>(a)</sup> Certified in accordance with the Unitary Air-conditioner equipment certification program which is based on AHRI standard 210/240.

<sup>(b)</sup> Calculated in accordance with N.E.C. Only use HACR circuit breakers or fuses.

<sup>(c)</sup> Reference the outdoor unit ship-with literature for refrigerant piping length and lift guidelines. Reference the refrigerant piping software pub # 32-3312-xx or refrigerant piping application guide SS-APG006-xx for long line sets or specialty applications (xx denotes latest revision).

<sup>(d)</sup> 25, 30, 35 and 50 foot linesets available. For a complete listing of lineset options available from equipment or supply stores, refer to the Trane Residential and Light Commercial Product Handbook.



## Product Specifications

Model No. <sup>(a)</sup>	5TTR4042A1000A	5TTR4048A1000A/B	5TTR4060A1000A/B
POWER CONNS. - V/PH/HZ <sup>(b)</sup>	208/230/1/60	208/230/1/60	208/230/1/60
MIN. BRCH. CIR. AMPACITY	21	23 / 25	28 / 30
BR. CIR. PROT. RTG. - MAX. (AMPS)	30	35 / 45	50
COMPRESSOR	CLIMATUFF® - SCROLL	CLIMATUFF® - SCROLL	CLIMATUFF® - SCROLL
RL AMPS - LR AMPS	14.7 - 109	17.3 - 126 / 19.6 - 118	21.8 - 143 / 23.4 - 134
Outdoor Fan FL AMPS	1.05	0.93	0.93
Fan HP	1/5	1/5	1/5
Fan Dia (inches)	27.5	27.5	27.5
Coil	SPINE FIN™	SPINE FIN™	SPINE FIN™
Refrigerant R-454B	5 LBS., 1 OZ	6 LBS., 10 OZ	5 LBS., 15 OZ
VALVE CONNECTION SIZE - IN. O.D. GAS	7/8	7/8	7/8
VALVE CONNECTION SIZE - IN. O.D. LIQ	5/16	5/16	5/16
LINE SIZE - IN. O.D. GAS <sup>(c)</sup>	7/8	7/8	7/8
LINE SIZE - IN. O.D. LIQ.	5/16	5/16	5/16
Charge Spec. Subcooling	10°F	10°F	10°F
Dimensions H x W X D Crated (IN.)	42.5 x 35 x 38	50.5 x 35 x 38	50.5 x 35 x 38
Weight - Shipping (lbs.)	246	307	302
Weight - Net (lbs.)	212	257	252
<b>Optional Accessories:</b>			
Anti-short Cycle Timer	TAYASCT501A	TAYASCT501A	TAYASCT501A
Evaporator Defrost Control	AY28X079	AY28X079	AY28X079
Rubber Isolator Kit	BAYISLT101	BAYISLT101	BAYISLT101
Extreme Condition Mount Kit	BAYECMT004	BAYECMT004	BAYECMT004
Start Kit	BAYKSKT263	BAYKSKT263	BAYKSKT263
Crankcase Heater Kit	BAYCCHT301	BAYCCHT301	BAYCCHT301
Seacoast Kit	BAYSEAC001	BAYSEAC001	BAYSEAC001
Low Ambient Kit	BAYLOAM103	BAYLOAM103	BAYLOAM103
Service Valve Panel Cover	TAYSVPANL0046AA	TAYSVPANL0046AA	TAYSVPANL0046AA
Refrigerant Lineset <sup>(d)</sup>			

<sup>(a)</sup> Certified in accordance with the Unitary Air-conditioner equipment certification program which is based on AHRI standard 210/240.

<sup>(b)</sup> Calculated in accordance with N.E.C. Only use HACR circuit breakers or fuses.

<sup>(c)</sup> Standard line lengths -150', Standard lift - 50' Suction and liquid line. For Greater lengths and lifts refer to refrigerant piping software Pub#32-3312-0\* (\* denotes latest revision).

<sup>(d)</sup> 25, 30, 35 and 50 foot linesets available. For a complete listing of lineset options available from equipment or supply stores, refer to the Trane Residential and Light Commercial Product Handbook.



## Product Specifications

### Sound Power Level

Sound Power Level									
MODEL	A-Weighted Sound Power Level [dB(A)]	Full Octave Sound Power(dB)							
		63 Hz*	125 Hz	250 Hz	500 Hz	1000 Hz	2000 Hz	4000 Hz	8000 Hz
5TTR4018A	73	79	69	67	70	70	64	59	53
5TTR4024A	71	78	72	69	68	66	61	58	53
5TTR4030A	73	79	69	67	70	70	64	59	53
5TTR4036A	71	78	72	69	68	66	61	58	53
5TTR4042A	71	78	72	69	68	66	61	58	53
5TTR4048A	71	81	75	71	70	68	63	58	53
5TTR4060A	71	81	75	71	70	68	63	58	53

**Note:** Rated in accordance with AHRI Standard 270-2008 \*For reference only.



# Accessory Description and Usage

**Anti-Short Cycle Timer** — Solid state timing device that prevents compressor recycling until five (5) minutes have elapsed after satisfying call or power interruptions. Use in area with questionable power delivery, commercial applications, long lineset, etc.

**Evaporation Defrost Control** — SPST Temperature actuated switch that cycles the condenser off as indoor coil reaches freeze-up conditions. Used for low ambient cooling to 30°F with TXV.

**Rubber Isolators** — Five (5) large rubber donuts to isolate condensing unit from transmitting energy into mounting frame or pad. Use on any application where sound transmission needs to be minimized.

**Hard Start Kit** — Start capacitor and relay to assist compressor motor startup. Use in areas with marginal power supply, on long linesets, low ambient conditions, etc.

**Extreme Condition Mount Kit** — Bracket kits to securely mount condensing unit to a frame or pad without removing any panels. Use in areas with high winds, or on commercial roof tops, etc.

## AHRI Standard Capacity Rating Conditions

AHRI Standard 210/240 Rating Conditions

1. Cooling 80°F DB, 67°F WB air entering indoor coil, 95°F DB air entering outdoor coil.
2. High Temperature Heating 47°F DB, 43°F WB air entering outdoor coil, 70°F DB air entering indoor coil.
3. Low Temperature Heating 17°F DB air entering indoor coil.
4. Rated indoor airflow for heating is the same as for cooling.

**AHRI Standard 270 Rating Conditions** — (Noise rating numbers are determined with the unit in cooling operations.) Standard Noise Rating number is at 95°F outdoor air.

# Model Nomenclature

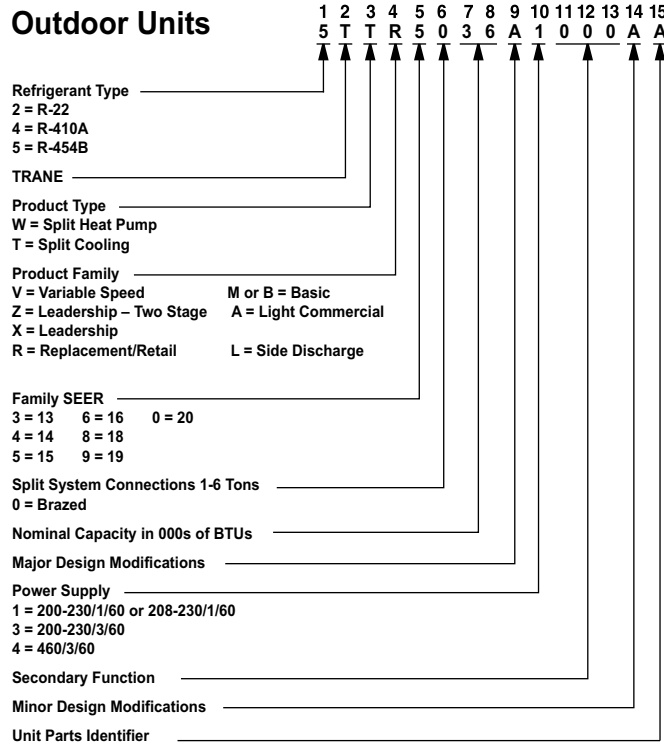

# Schematic Diagrams

**Figure 1. 018A – 048A Models**

TO POWER SUPPLY PER UNIT NAMEPLATE AND LOCAL CODES

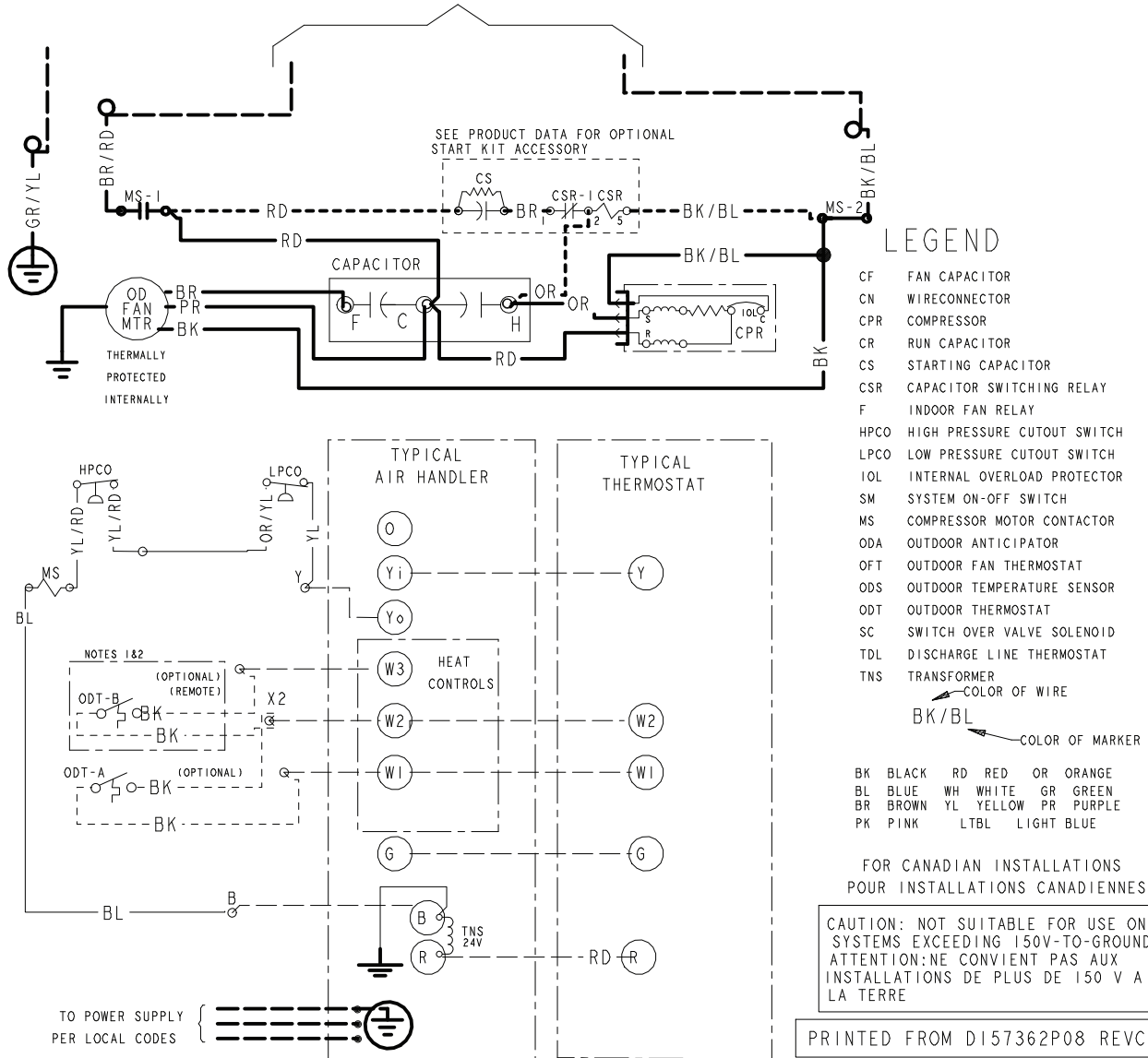

**Figure 2. 018A – 048A Models**

**NOTES:**

1. IF ODT-B IS NOT USED, ADD JUMPER BETWEEN W2 & W3 AT AIR HANDLER. IF USED, ODT-B MUST BE MOUNTED REMOTE OF CONTROL BOX IN AN APPROVED WEATHER PROOF ENCLOSURE.
2. IF ODT-A IS NOT USED, ADD JUMPER BETWEEN W1 & W2 AT AIR HANDLER.
3. LOW VOLUME (24 V) FIELD WIRING MUST BE 18 AWG MIN.
- ▲ 4. FIELD GROUND MUST BE ATTACHED TO THE GROUND LUG ON THE RUNTRU AND AMERISTAR UNITS.
- ▲ 5. GROUND CONNECTION FOR TRANE/ AMERICAN STANDARD ONLY.

**LEGEND**

- 24 V } FACTORY LINE WIRING
- 24 V } FIELD LINE WIRING
- FIELD INSTALLED FACTORY WIRING
- MAGNETIC COIL
- GROUND
- JUNCTION
- CAPACITOR
- WIRE NUT OR
- TERMINAL
- TRANSFORMER
- FUSE
- TERMINAL BLOCK/BOARD
- RELAY CONTACT (N.O.)
- RELAY CONTACT (N.C.)
- THERMISTOR
- TEMP ACTUATED SWITCH
- INTERNAL OVERLOAD PROTECTION
- PRESSURE ACTUATED SWITCH
- RESISTOR OR HEATING ELEMENT
- MOTOR WINDING
- POL. PLUG FEMALE HOUSING (MALE TERMINALS)
- POL. PLUG MALE HOUSING (FEMALE TERMINALS)

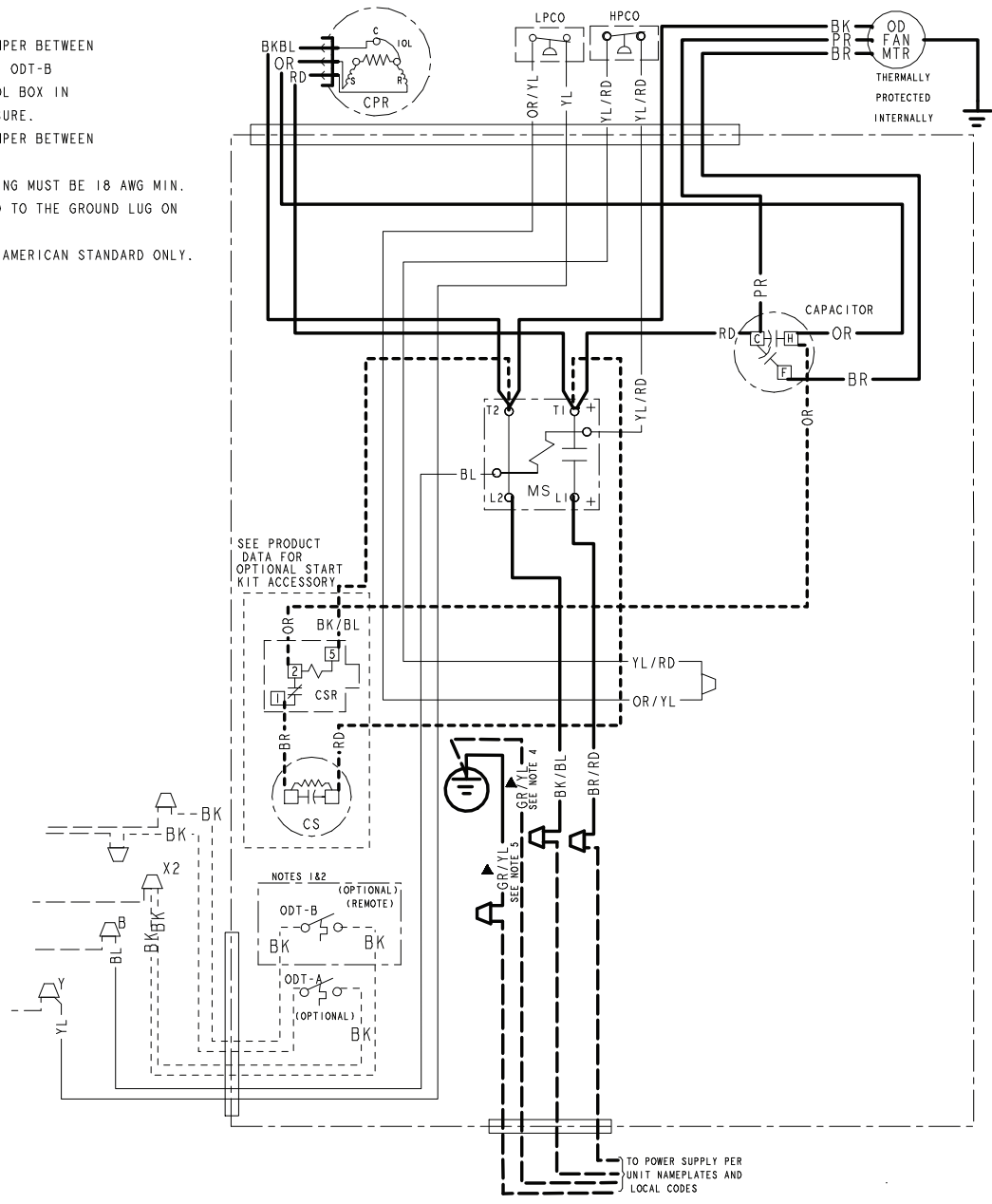

PRINTED FROM D157362P08 REV C

**Figure 3. 060A Models**

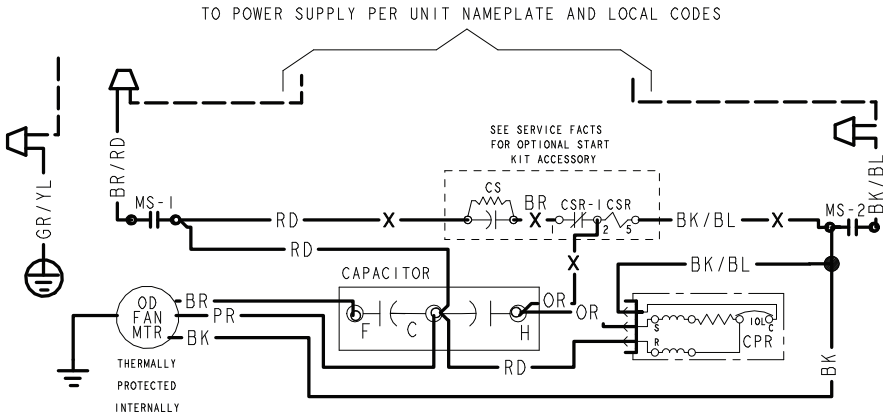

**LEGEND**

- CF FAN CAPACITOR
- CN WIRE CONNECTOR
- CPR COMPRESSOR
- CR RUN CAPACITOR
- CS STARTING CAPACITOR
- CSR CAPACITOR SWITCHING RELAY
- ODT OUTDOOR THERMOSTAT
- HPCO HIGH PRESSURE CUTOUT SWITCH
- LPCO LOW PRESSURE CUTOUT SWITCH
- MS COMPRESSOR MOTOR CONTACTOR
- TNS TRANSFORMER
- IOL INTERNAL OVERLOAD PROTECTOR

← COLOR OF WIRE  
 BK/BL ← COLOR OF MARKER

- BK BLACK RD RED OR ORANGE
- BL BLUE WH WHITE GR GREEN
- BR BROWN YL YELLOW PR PURPLE
- PK PINK

FOR CANADIAN INSTALLATIONS  
 POUR INSTALLATIONS CANADIENNES

CAUTION: NOT SUITABLE FOR USE ON SYSTEMS EXCEEDING 150V-TO-GROUND  
 ATTENTION: NE CONVIENT PAS AUX INSTALLATIONS DE PLUS DE 150 V A LA TERRE

PRINTED FROM DI60963P01 REV C

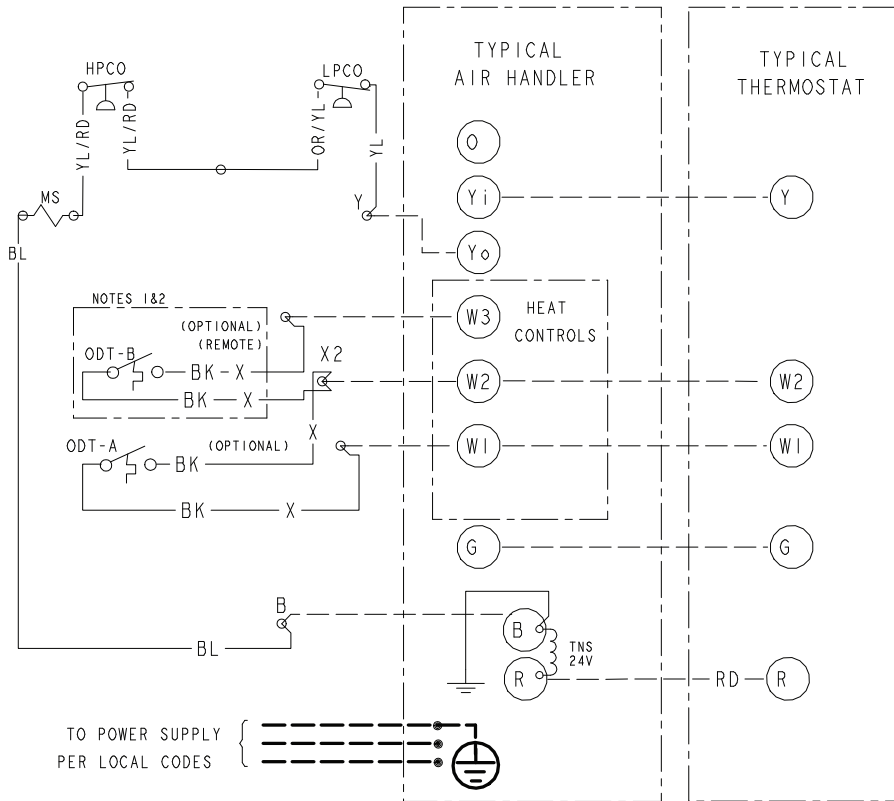

TO POWER SUPPLY  
 PER LOCAL CODES



### Figure 4. 060A Models

**NOTES:**

1. IF ODT-B IS NOT USED. ADD JUMPER BETWEEN W2 & W3 AT AIR HANDLER. IF USED, ODT-B MUST BE MOUNTED REMOTE OF CONTROL BOX IN AN APPROVED WEATHER PROOF ENCLOSURE.
2. IF ODT-A IS NOT USED. ADD JUMPER BETWEEN W1 & W2 AT AIR HANDLER.
3. LOW VOLTAGE (24 V) FIELD WIRING MUST BE 18 AWG MINIMUM.
4. USE COPPER CONDUCTORS ONLY!
- ▲ 5. FIELD GROUND MUST BE ATTACHED TO THE GROUND LUG ON THE RUNTRU AND AMERISTAR UNITS.
- ▲ 6. GROUND CONNECTION FOR TRANE/ AMERICAN STANDARD ONLY.

## LEGEND

- 24 V } FACTORY  
LINE } WIRING
- - - 24 V } FIELD  
LINE } WIRING
- X - 24 V } FIELD INSTALLED  
- X - LINE } FACTORY WIRING
- ⎓ MAGNETIC COIL
- ⊕ GROUND
- JUNCTION
- ⊢ CAPACITOR
- ⊢ WIRE NUT OR CONNECTOR
- TERMINAL
- ⎓ TRANSFORMER
- TERMINAL BLOCK/BOARD
- ⊢ RELAY CONTACT (N.O)
- ⊢ RELAY CONTACT (N.C)
- ⊡ THERMISTOR
- ⊡ TEMP ACTUATED SWITCH
- ⊡ INTERNAL OVERLOAD PROTECTION
- ⊡ PRESSURE ACTUATED SWITCH
- ⊡ RESISTOR OR HEATING ELEMENT
- ⊡ MOTOR WINDING
- ⊡ POL. PLUG FEMALE HOUSING (MALE TERMINALS)
- ⊡ POL. PLUG MALE HOUSING (FEMALE TERMINALS)

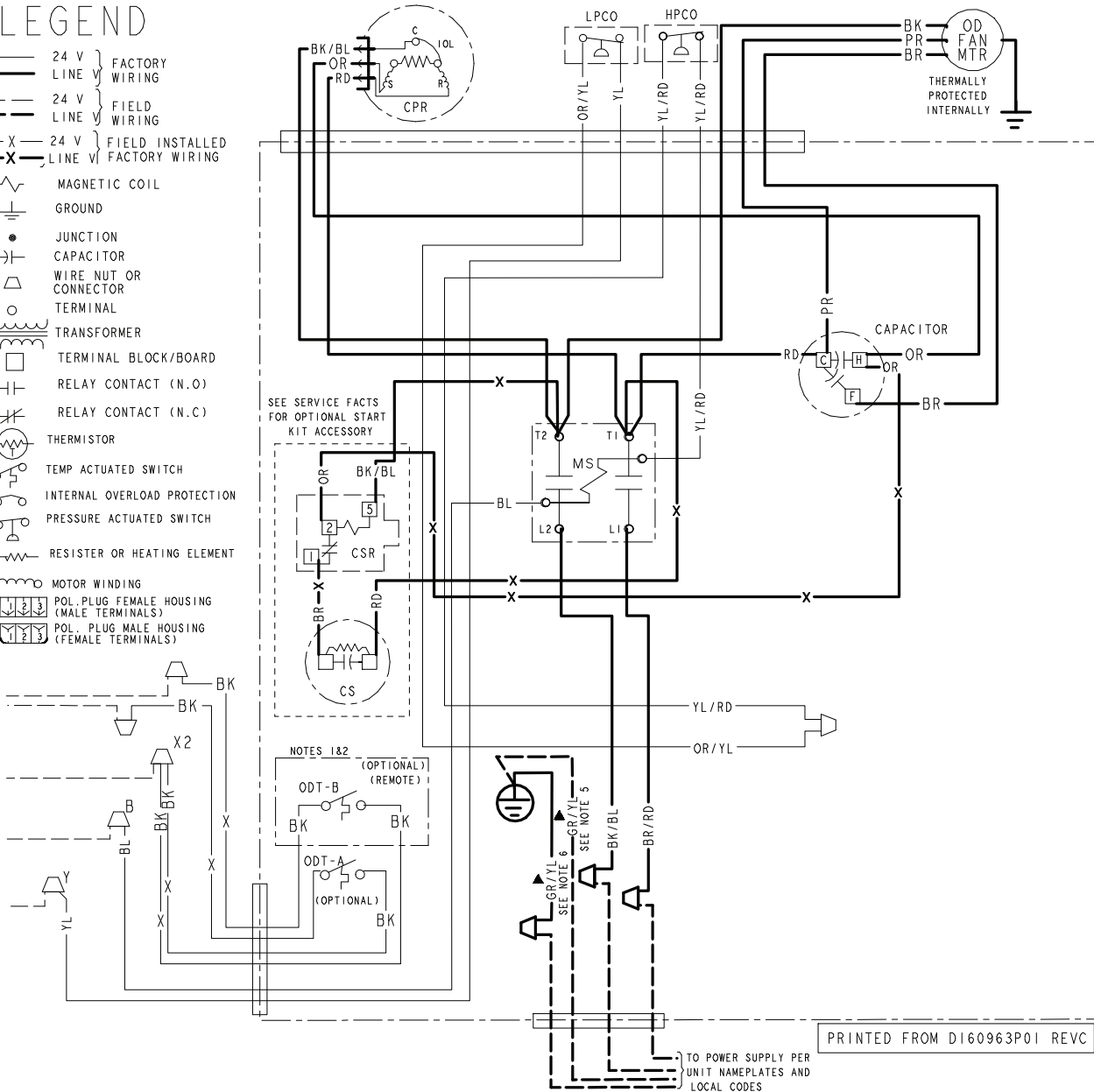



# Outline Drawing

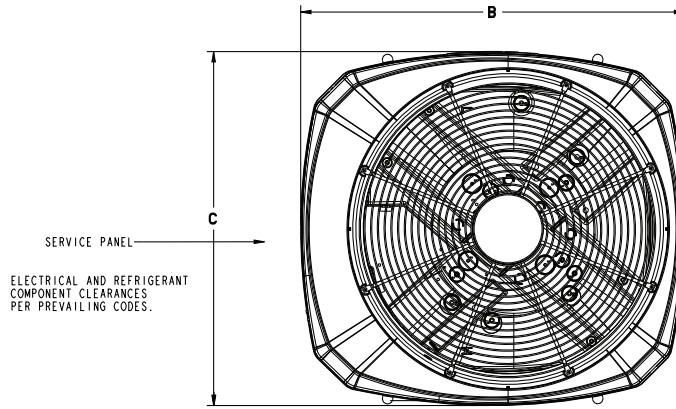

TOP DISCHARGE AREA SHOULD BE UNRESTRICTED FOR AT LEAST 1524 (5 FEET) ABOVE UNIT. UNIT SHOULD BE PLACED SO ROOF RUN-OFF WATER DOES NOT POUR DIRECTLY ON UNIT, AND SHOULD BE AT LEAST 305 (12") FROM WALL AND ALL SURROUNDING SHRUBBERY ON TWO SIDES. OTHER TWO SIDES UNRESTRICTED.

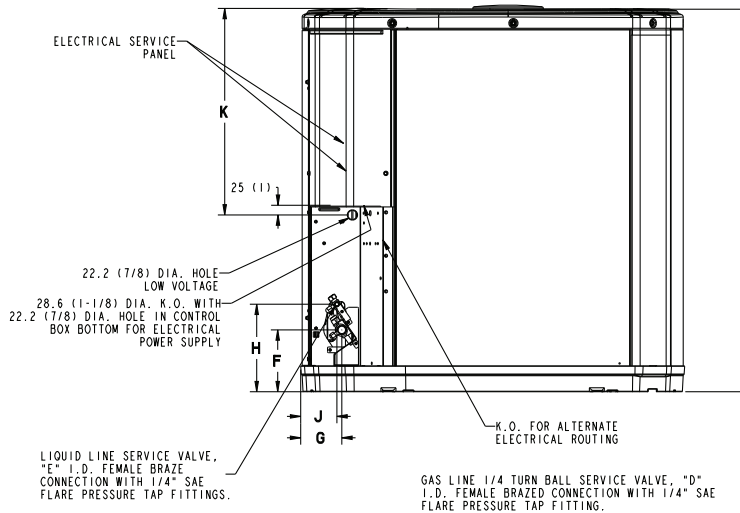

Model	Base	A	B	C	D	E	F	G	H	J	K
5TTR4018A	3	933 (36-3/4)	829 (32-5/8)	756 (29-3/4)	3/4	5/16	143 (5-5/8)	92 (3-5/8)	210 (8-1/4)	79 (3-1/8)	508 (20)
5TTR4024A	3	832 (32-3/4)	829 (32-5/8)	756 (29-3/4)	3/4	5/16	127 (5)	76 (3)	197 (7-3/4)	60 (2-3/8)	508 (20)
5TTR4030A	3	933 (36-3/4)	829 (32-5/8)	756 (29-3/4)	3/4	5/16	143 (5-5/8)	92 (3-5/8)	210 (8-1/4)	79 (3-1/8)	508 (20)
5TTR4036A	3	832 (32-3/4)	829 (32-5/8)	756 (29-3/4)	3/4	5/16	127 (5)	76 (3)	197 (7-3/4)	60 (2-3/8)	508 (20)
5TTR4042A	4	943 (37-1/8)	946 (37-1/4)	870 (34-1/4)	7/8	5/16	143 (5-5/8)	98 (3-7/8)	219 (8-5/8)	86 (3-3/8)	508 (20)
5TTR4048A	4	1147 (45-1/8)	946 (37-1/4)	870 (34-1/4)	7/8	5/16	152 (6)	98 (3-7/8)	219 (8-5/8)	86 (3-3/8)	813 (32)
5TTR4060A	4	1147 (45-1/8)	946 (37-1/4)	870 (34-1/4)	7/8	5/16	152 (6)	98 (3-7/8)	219 (8-5/8)	86 (3-3/8)	813 (32)



# Mechanical Specification Options

## General

The outdoor condensing units are factory charged with the system charge required for the outdoor condensing unit, ten (10) feet of tested connecting line, and the smallest rated indoor evaporative coil match. This unit is designed to operate at outdoor ambient temperatures as high as 115°F. Cooling capacities are matched with a wide selection of air handlers and furnace coils that are AHRI certified. The unit is certified to UL 60335-2-40. Exterior is designed for outdoor application.

## Casing

Unit casing is constructed of heavy gauge, galvanized steel and painted with a weather-resistant powder paint finish. The corner panels are prepainted. All panels are subjected to our 1,000 hour salt spray test.

## Refrigerant Controls

Refrigeration system controls include condenser fan, compressor contactor and low and high pressure switches. A factory supplied, field installed liquid line drier is standard.

## Compressor

The compressor features internal over temperature and pressure protection. Other features include: Centrifugal oil pump and low vibration and noise.

## Condenser Coil

The outdoor coil provides low airflow resistance and efficient heat transfer. The coil is protected on all four sides by louvered panels.

## Low Ambient Cooling

As manufactured, this system has a cooling capacity to 55°F. The addition of an evaporator defrost control permits operation to 40°F. The addition of an evaporator defrost control with TXV permits low ambient cooling to 30°F.

The addition of the BAYLOAM107A low ambient kit permits ambient cooling to 20°F.

**Thermostats** – Cooling only and heat/cooling (manual and automatic change over). Sub-base to match thermostat and locking thermostat cover.



Trane - by Trane Technologies (NYSE: TT), a global innovator - creates comfortable, energy efficient indoor environments for commercial and residential applications. For more information, please visit [trane.com](http://trane.com) or [tranetechnologies.com](http://tranetechnologies.com).

---



The AHRI Certified mark indicates Trane U.S. Inc. participation in the AHRI Certification program. For verification of individual certified products, go to [ahrirectory.org](http://ahrirectory.org).

Trane has a policy of continuous data improvement and it reserves the right to change design and specifications without notice. We are committed to using environmentally conscious print practices.