

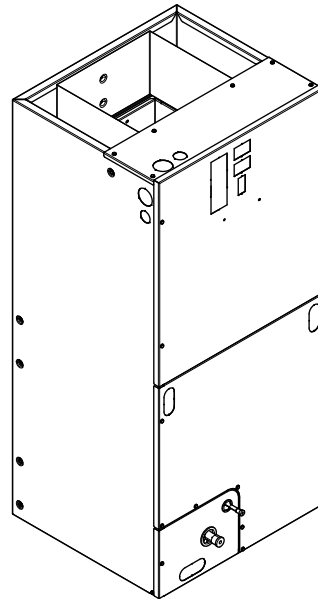

# Product Data

## Convertible Air Handlers 2 – 5 Ton

TEM4B0B24M21SA  
TEM4A0B31M31SB  
TEM4A0C42S41SC  
TEM4B0C37M31SA  
TEM4A0C43M41SB  
TEM4A0C48S41SC  
TEM4A0C49M41SB  
TEM4B0C60S51SA



*The TEM4 series air handler is designed for installation in a closet, utility room, alcove, basement, crawlspace or attic. These versatile units are applicable to air conditioning and heat pump applications. Several models are available to meet the specific requirements of the outdoor equipment. Field installed electric resistance heaters are available.*



# Table of Contents

Features and Benefits.....	3
Optional Equipment.....	3
Product Specifications.....	4
Heater Pressure Drop Table TEM Air Handler Models.....	6
Minimum Airflow CFM .....	7
Air Handler and Heater Matrix Allowable Combinations .....	8
Performance and Electrical Data .....	9
Electrical Data .....	14
Field Wiring.....	15
TEM Convertibility.....	16
TEM4 Air Handler Dimensional Data.....	17
Outline Drawing .....	18



## Features and Benefits

- Painted metal cabinet with captured foil face insulation
- 2% or less air leakage
- R-4.2 Insulating Value
- Multi-Position UP/Down Flow, Horizontal Left /Right
- ALL Aluminum Coil
- Electric Heaters with polarized plug connections (sold as accessory)
- R-410A Thermal Expansion Valve
- ECM Motor
- Low Voltage Pigtail Connections
- Draw Through Design
- Horizontal Drain pan
- Fused 24V Power
- **3 year warranty**
- **10-year warranty registered**
- **Optional extended warranty available**

*Important: Condensate management kit is required for all 5 ton air handler models installed in downflow applications.*

## Optional Equipment

Accessory Number	Description	Fits Cabinet Size
BAYHTR1504BRK	Electric Heater, 4KW, Breaker, 24V Control, 1 Ph	18.5" and 23.5"
BAYHTR1504LUG	Electric Heater, 4KW, Lug, 24V Control, 1 Ph	18.5" and 23.5"
BAYHTR1505BRK	Electric Heater, 5KW, Breaker, 24V Control, 1 Ph	18.5" and 23.5"
BAYHTR1505LUG	Electric Heater, 5KW, Lug, 24V Control, 1 Ph	18.5" and 23.5"
BAYHTR1508BRK	Electric Heater, 8KW, Breaker, 24V Control, 1 Ph	18.5" and 23.5"
BAYHTR1508LUG	Electric Heater, 8KW, Lug, 24V Control, 1 Ph	18.5" and 23.5"
BAYHTR1510BRK	Electric Heater, 10KW, Breaker, 24V Control, 1 Ph	18.5" and 23.5"
BAYHTR1510LUG	Electric Heater, 10KW, Lug, 24V Control, 1 Ph	18.5" and 23.5"
BAYHTR3510LUG	Electric Heater, 10KW, Lug, 24V Control, 3 Ph	18.5" and 23.5"
BAYHTR1515BRK	Electric Heater, 15KW, Breaker, 24V Control, 1 Ph	18.5" and 23.5"
BAYHTR1517BRK	Electric Heater, 15KW, Breaker, 24V Control, 1 Ph	18.5" and 23.5"
BAYHTR3515LUG	Electric Heater, 15KW, Lug, 24V Control, 3 Ph	18.5" and 23.5"
BAYHTR3517LUG	Electric Heater, 15KW, Lug, 24V Control, 3 Ph	18.5" and 23.5"
BAYHTR1519BRK	Electric Heater, 20KW, Breaker, 24V Control, 1 Ph	18.5"
BAYHTR1520BRK	Electric Heater, 20KW, Breaker, 24V Control, 1 Ph	23.5"
BAYHTR1521BRK	Electric Heater, 20KW, Breaker, 24V Control, 1 Ph	23.5"
BAYHTR1523BRK	Electric Heater, 20KW, Breaker, 24V Control, 1 Ph	23.5"
BAYHTR1525BRK	Electric Heater, 25KW, Breaker, 24V Control, 1 Ph	23.5"
BAYTEMSPFG1A	Supply Duct Flange Kit	18.5" and 23.5"
BAYSPEKT201A	Single Point Power Entry Kit	18.5" and 23.5"
TAYBASE185	Air Handler Downflow Sub-Bases	18.5"
TAYBASE235 (TAYBASE 100)	Air Handler Downflow Sub-Bases	23.5"
BAYSF1185AAA	Slim Fit Filter Box	18.5"
BAYSF1235AAA	Slim Fit Filter Box	23.5"
TEMBRKSEALT01A	Breaker Seal Kit for sure with BAYHTR15 4kW — 20kW Heaters	18.5" and 23.5"
TEMBRKSEALT25A	Breaker Seal Kit for use with 25 kW electric heaters & heater kits used with BAYSPEKT201	18.5" and 23.5"



# Product Specifications

MODEL	TEM4B0B24M21SA	TEM4A0B31M31SB	TEM4A0C42S41SC	TEM4B0C37M31SA
<b>RATED VOLTS/PH/HZ</b>	208-230/1/60	208-230/1/60	208-230/1/60	208-230/1/60
<b>RATINGS<sup>(a)</sup></b>	See O.D. Specifications	See O.D. Specifications	See O.D. Specifications	See O.D. Specifications
<b>INDOOR COIL — Type</b>	Plate Fin	Plate Fin	Plate Fin	Plate Fin
Rows — F.P.I.	3 - 14	4 - 14	3 - 14	4 - 14
Face Area (sq. ft.)	4.37	3.44	5.50	4.59
Tube Size (in.)	3/8	3/8	3/8	3/8
Refrigerant Control	TXV	TXV	TXV	TXV
Drain Conn. Size (in.) <sup>(b)</sup>	3/4 NPT	3/4 NPT	3/4 NPT	3/4 NPT
<b>DUCT CONNECTIONS</b>	<b>See Outline Drawing</b>	<b>See Outline Drawing</b>	<b>See Outline Drawing</b>	<b>See Outline Drawing</b>
<b>INDOOR FAN — Type</b>	Centrifugal	Centrifugal	Centrifugal	Centrifugal
Diameter-Width (In.)	11 X 6	11 X 8	11 X 8	11 X 8
No. Used	1	1	1	1
Drive - No. Speeds	Direct - 4	Direct - 5	Direct - 3	Direct - 5
CFM vs. in. w.g.	See Fan Performance Table	See Fan Performance Table	See Fan Performance Table	See Fan Performance Table
No. Motors — H.P.	1 - 1/3	1 - 1/3	1 - 1/2	1 - 1/2
Motor Speed R.P.M.	1050	1050	1050	1050
Volts/Ph/Hz	208-230/1/60	208-230/1/60	208-230/1/60	208-230/1/60
F.L. Amps	2.8	2.8	4.1	4.1
<b>FILTER</b>				
Filter Furnished? <sup>(c)</sup>	No	No	No	No
<b>REFRIGERANT</b>	<b>R-410A</b>	<b>R-410A</b>	<b>R-410A</b>	<b>R-410A</b>
Ref. Line Connections	Brazed	Brazed	Brazed	Brazed
Coupling or Conn. Size — in. Gas	3/4	3/4	7/8	7/8
Coupling or Conn. Size — in. Liq.	3/8	3/8	3/8	3/8
<b>DIMENSIONS</b>	H x W x D	H x W x D	H x W x D	H x W x D
Crated (In.)	46 x 21 x 24	48-1/4 x 22-1/2 x 25-1/2	52-1/2 x 26 x 24	52-3/4 x 27-1/2 x 25-1/2
Uncrated	45-1/8 x 18-1/2 x 21-1/8	46-3/4 x 18-1/2 x 21-1/8	51-3/8 x 23-1/2 x 21-1/8	51-3/8 x 23-1/2 x 21-1/8
<b>WEIGHT</b>				
Shipping (Lbs.) / Net (Lbs.)	116/110	145/138	145/138	155/144

<sup>(a)</sup> These Air Handlers are A.H.R.I certified with various Split System Air Conditioners and Heat Pumps (AHRI STANDARD 210/240). Refer to the Split System Outdoor Unit Product Data Guides for performance data.

<sup>(b)</sup> 3/4" Male Plastic Pipe (Ref: ASTM 1785-76)

<sup>(c)</sup> Remote filter required.

## Product Specifications

MODEL	TEM4A0C43M41SB	TEM4A0C48S41SC	TEM4A0C49M41SB	TEM4B0C60S51SA
<b>RATED VOLTS/PH/HZ</b>	208-230/1/60	208-230/1/60	208-230/1/60	208-230/1/60
<b>RATINGS<sup>(a)</sup></b>	See O.D. Specifications	See O.D. Specifications	See O.D. Specifications	See O.D. Specifications
<b>INDOOR COIL — Type</b>	Plate Fin	Plate Fin	Plate Fin	Plate Fin
Rows — F.P.I.	4 - 14	3 - 14	3 - 16	3 - 16
Face Area (sq. ft.)	4.59	5.50	7.9	7.9
Tube Size (in.)	3/8	3/8	3/8	3/8
Refrigerant Control	TXV	TXV	TXV	TXV
Drain Conn. Size (in.) <sup>(b)</sup>	3/4 NPT	3/4 NPT	3/4 NPT	3/4 NPT
<b>DUCT CONNECTIONS</b>	<b>See Outline Drawing</b>	<b>See Outline Drawing</b>	<b>See Outline Drawing</b>	<b>See Outline Drawing</b>
<b>INDOOR FAN — Type</b>	Centrifugal	Centrifugal	Centrifugal	Centrifugal
Diameter-Width (In.)	11 X 8	11 X 8	11 X 11	11 X 11
No. Used	1	1	1	1
Drive - No. Speeds	Direct - 5	Direct - 3	Direct - 5	Direct - 5
CFM vs. in. w.g.	See Fan Performance Table	See Fan Performance Table	See Fan Performance Table	See Fan Performance Table
No. Motors — H.P.	1 - 1/2	1 - 3/4	1 - 3/4	1 - 3/4
Motor Speed R.P.M.	1050	1050	1050	1050
Volts/Ph/Hz	208-230/1/60	208-230/1/60	208-230/1/60	208-230/1/60
F.L. Amps	4.1	6.0	6.0	6.0
<b>FILTER</b>				
Filter Furnished? <sup>(c)</sup>	No	No	No	No
<b>REFRIGERANT</b>	<b>R-410A</b>	<b>R-410A</b>	<b>R-410A</b>	<b>R-410A</b>
Ref. Line Connections	Brazed	Brazed	Brazed	Brazed
Coupling or Conn. Size — in. Gas	7/8	7/8	7/8	7/8
Coupling or Conn. Size — in. Liq.	3/8	3/8	3/8	3/8
<b>DIMENSIONS</b>	H x W x D	H x W x D	H x W x D	H x W x D
Crated (In.)	52-3/4 x 27-1/2 x 25-1/2	52-1/2 x 26 x 24	57-11/16 x 27-1/2 x 25-1/2	57-11/16 x 27-1/2 x 25-1/2
Uncrated	51-3/8 x 23-1/2 x 21-1/8	51-3/8 x 23-1/2 x 21-1/8	57-3/8 x 23-1/2 x 21-1/8	57-3/8 x 23-1/2 x 21-1/8
<b>WEIGHT</b>				
Shipping (Lbs.) / Net (Lbs.)	155/144	145/138	185/174	185/174

<sup>(a)</sup> These Air Handlers are A.H.R.I certified with various Split System Air Conditioners and Heat Pumps (AHRI STANDARD 210/240). Refer to the Split System Outdoor Unit Product Data Guides for performance data.

<sup>(b)</sup> 3/4" Male Plastic Pipe (Ref: ASTM 1785-76)

<sup>(c)</sup> Remote filter required.



# Heater Pressure Drop Table TEM Air Handler Models

Airflow CFM	Number of Racks				Heater Racks	
	1	2	3	4	Heater Model	No. of Racks
	Air Pressure Drop — Inches W.G.					
1800	0.02	0.04	0.06	0.14	BAYHTR1504	1
1700	0.02	0.04	0.06	0.14	BAYHTR1505	1
1600	0.02	0.04	0.06	0.13	BAYHTR1508	2
1500	0.02	0.04	0.06	0.12	BAYHTR1510	2
1400	0.02	0.04	0.06	0.12	BAYHTR3510	3
1300	0.02	0.04	0.05	0.11	BAYHTR1517	3
1200	0.01	0.04	0.05	0.10	BAYHTR3517	3
1100	0.01	0.03	0.05	0.09	BAYHTR1523	4
1000	0.01	0.03	0.04	0.09	BAYHTR1525	4
900	0.01	0.03	0.04	0.08		
800	0.01	0.03				
700	0.01	0.02				
600	0.01	0.02				



# Minimum Airflow CFM

TEM4B0B24M21SA		
Heater	Minimum Heat Speed Tap	
	With Heat Pump	Without Heat Pump
BAYHTR1504BRK, BAYHTR1504LUG, BAYHTR1505BRK, BAYHTR1505LUG	Low	Low
BAYHTR1508BRK, BAYHTR1508LUG, BAYHTR1510BRK, BAYHTR1510LUG, BAYHTR3510LUG	High	Med

TEM4A0B31M31SB		
Heater	Minimum Heat Speed Tap	
	With Heat Pump	Without Heat Pump
BAYHTR1504BRK, BAYHTR1504LUG, BAYHTR1505BRK, BAYHTR1505LUG	Low	Low
BAYHTR1508BRK, BAYHTR1508LUG, BAYHTR1510BRK, BAYHTR1510LUG	Med-High	Med-Low
BAYHTR1517BRK, BAYHTR3517LUG, BAYHTR3510LUG	High	Med

TEM4A0C42S41SC		
Heater	Minimum Heat Speed Tap	
	With Heat Pump	Without Heat Pump
BAYHTR1504BRK, BAYHTR1504LUG, BAYHTR1505BRK, BAYHTR1505LUG	Low	Low
BAYHTR1508BRK, BAYHTR1508LUG, BAYHTR1510BRK, BAYHTR1510LUG, BAYHTR3510LUG	Low	Low
BAYHTR1517BRK	Low	Low
BAYHTR1523BRK	Med	Low
BAYHTR3517LUG	Low	Low

TEM4B0C37M31SA, TEM4A0C43M41SB		
Heater	Minimum Heat Speed Tap	
	With Heat Pump	Without Heat Pump
BAYHTR1504BRK, BAYHTR1504LUG, BAYHTR1505BRK, BAYHTR1505LUG	Low	Low
BAYHTR1508BRK, BAYHTR1508LUG, BAYHTR1510BRK, BAYHTR1510LUG	Med-High	Med-Low
BAYHTR1523BRK	Med-High	Med
BAYHTR1517BRK, BAYHTR3517LUG, BAYHTR3510LUG	High	Med

TEM4A0C48S41SC		
Heater	Minimum Heat Speed Tap	
	With Heat Pump	Without Heat Pump
BAYHTR1504BRK, BAYHTR1504LUG, BAYHTR1505BRK, BAYHTR1505LUG	Low	Low
BAYHTR1508BRK, BAYHTR1508LUG, BAYHTR1510BRK, BAYHTR1510LUG, BAYHTR3510LUG	Low	Low
BAYHTR1517BRK	Low	Low
BAYHTR1523BRK	Low	Low
BAYHTR1525BRK	Low	Low
BAYHTR3517LUG	Low	Low

TEM4A0C49M41SB, TEM4B0C60S51SA		
Heater	Minimum Heat Speed Tap	
	With Heat Pump	Without Heat Pump
BAYHTR1504BRK, BAYHTR1504LUG, BAYHTR1505BRK, BAYHTR1505LUG, BAYHTR1508BRK, BAYHTR1508LUG, BAYHTR1510BRK, BAYHTR1510LUG, BAYHTR3510LUG	Med-Low	Med-Low
BAYHTR1517BRK, BAYHTR3517LUG	Med	Med
BAYHTR1523BRK, BAYHTR1525BRK	Med-High	Med



# Air Handler and Heater Matrix Allowable Combinations

Table 1. TEM4 MINIMUM HEATER AIRFLOW CFM – HEATER MATRIX

Model No.	BAYHTR1504BRK * BAYHTR1504LUG * BAYHTR1505BRK * BAYHTR1505LUG *	BAYHTR1508BRK * BAYHTR1508LUG * BAYHTR1510BRK * BAYHTR1510LUG * BAYHTR3510LUG *	BAYHTR1517BRK *	BAYHTR1523BRK *	BAYHTR1525BRK *	BAYHTR3517LUG *
TEM4B0B24M21SA *	L / L	M / H	--	--	--	--
TEM4A0B31M31SB *	L / L	M-L / M-H	M / H	--	--	M / H
TEM4A0C42S41SC *	L / L	L / L	L / L	L / M	--	L / L
TEM4B0C37M31SA *	L / L	L / L	L / L	L / M	--	L / L
TEM4A0C43M41SB *	L / L	M-L / M-H	M / H	M / M-H	--	M / H
TEM4A0C48S41SC *	L / L	L / L	L / L	L / L	L / L	L / L
TEM4A0C49M41SB *	M-L / M-L	M-L / M-L	M / M	M / M-H	M / M-H	M / M
TEM4B0C60S51SA *	M-L / M-L	M-L / M-L	M / M	M / M-H	M / M-H	M / M

1. Cooling / HP Airflow  
 2. \* = Followed by two digits





# Performance and Electrical Data

**Table 2. Air Flow Performance Tables**

<b>TEM4B0B24M21SA</b>				
EXTERNAL STATIC (in w.g)	AIRFLOW			
	Speed Taps: 208 – 230 VOLTS			
	<b>High</b>	<b>Med-High</b>	<b>Med †</b>	<b>Low</b>
0.1	1140	1078	930	851
0.2	1087	1017	870	796
0.3	1034	955	807	733
0.4	978	894	741	663
0.5	922	834	671	584
0.6	863	774	597	497
0.7	804	715	519	403

- Low = Taps 1-2, Med = Tap 3, Med-High= Tap 4, High = Tap 5

<b>TEM4A0B31M31SB</b>					
EXTERNAL STATIC (in w.g)	AIRFLOW				
	Speed Taps: 208 – 230 VOLTS				
	<b>High</b>	<b>Med-High</b>	<b>Med †</b>	<b>Med-Low</b>	<b>Low</b>
0.1	1192	1127	1070	995	940
0.2	1148	1079	1021	943	885
0.3	1103	1031	971	890	828
0.4	1057	980	919	834	767
0.5	1009	929	865	775	702
0.6	961	875	810	714	635
0.7	911	820	753	651	564

- Low = Tap 1, Med-Low = Tap 2, Med = Tap 3, Med-High= Tap 4, High = Tap 5

<b>TEM4A0C42S41SC</b>			
EXTERNAL STATIC (in w.g)	AIRFLOW		
	Speed Taps: 208-230 VOLTS		
	<b>High</b>	<b>Med</b>	<b>Low †</b>
0.1	1623	1509	1403
0.2	1583	1465	1357
0.3	1539	1420	1309
0.4	1494	1373	1260
0.5	1450	1326	1211
0.6	1399	1276	1159
0.7	1353	1223	1102

- In downflow applications, airflow must not exceed 1600 cfm due to condensate blowoff.
- Low = Taps 1-3, Med = Tap 4, High = Tap 5



## Performance and Electrical Data

TEM4B0C37M31SA, TEM4A0C43M41SB					
EXTERNAL STATIC (in w.g)	AIRFLOW				
	Speed Taps: 208 – 230 VOLTS				
	High	Med-High	Med †	Med-Low	Low
0.1	1492	1418	1302	1268	1140
0.2	1460	1385	1266	1230	1096
0.3	1426	1349	1228	1190	1050
0.4	1390	1311	1187	1147	1002
0.5	1352	1271	1144	1101	952
0.6	1311	1229	1099	1053	899
0.7	1269	1184	1051	1003	845

- In downflow applications, airflow must not exceed 1600 cfm due to condensate blowoff.
- Low = Tap 1, Med-Low = Tap 2, Med = Tap 3, Med-High= Tap 4, High = Tap 5

TEM4A0C48S41SC			
EXTERNAL STATIC (in w.g)	AIRFLOW		
	Speed Taps: 208–230 VOLTS		
	High	Med	Low †
0.1	1784	1698	1634
0.2	1748	1662	1595
0.3	1715	1627	1559
0.4	1682	1591	1521
0.5	1650	1558	1488
0.6	1618	1525	1455
0.7	1499	1494	1422

- In downflow applications, airflow must not exceed 1600 cfm due to condensate blowoff.
- Low = Taps 1–3, Med = Tap 4, High = Tap 5

TEM4A0C49M41SB, TEM4B0C60S51SA					
EXTERNAL STATIC (in w.g)	AIRFLOW				
	Speed Taps: 208 – 230 VOLTS				
	High	Med-High	Med †	Med-Low	Low
0.1	2040	1874	1658	1512	1373
0.2	2008	1846	1622	1476	1333
0.3	1975	1816	1585	1438	1289
0.4	1942	1785	1546	1395	1240
0.5	1909	1751	1506	1349	1187
0.6	1875	1716	1463	1300	1129
0.7	1841	1678	1418	1246	1067

- In downflow applications, airflow must not exceed 1800 cfm due to condensate blowoff.
- Low = Tap 1, Med-Low = Tap 2, Med = Tap 3, Med-High= Tap 4, High = Tap 5

**Notes:**

- Values are with wet coil, no filter, and no heaters
- CFM Correction for dry coil = Add 3%
- † = Factory Setting

**Table 3. Electrical Data**

<b>TEM4B0B24M21SA</b>											
Heater Model No.	No. of Circuits/ Phases	240 Volt					208 Volt				
		Capacity		Heater Amps per Circuit	Minimum Circuit Ampacity	Maximum Overload Protection	Capacity		Heater Amps per Circuit	Minimum Circuit Ampacity	Maximum Overload Protection
		kW	BTUH				kW	BTUH			
No Heater				2.8 *	4	15			2.8 *	4	15
BAYHTR1504BRK BAYHTR1504LUG	1/1	3.8	13100	16.0	24	25	2.9	9800	13.8	21	25
BAYHTR1505BRK BAYHTR1505LUG	1/1	4.8	16400	20.0	29	30	3.6	12300	17.3	25	25
BAYHTR1508BRK BAYHTR1508LUG	1/1	7.7	26200	32.0	44	45	5.8	19700	27.7	38	40
BAYHTR1510BRK BAYHTR1510LUG	1/1	9.6	32800	40.0	54	60	7.2	24600	34.6	47	50
BAYHTR3510LUG	1/3	9.6	32800	23.1	32	35	7.2	24600	20.0	28	30

<b>TEM4A0B31M31SB</b>											
Heater Model No.	No. of Circuits/ Phases	240 Volt					208 Volt				
		Capacity		Heater Amps per Circuit	Minimum Circuit Ampacity	Maximum Overload Protection	Capacity		Heater Amps per Circuit	Minimum Circuit Ampacity	Maximum Overload Protection
		kW	BTUH				kW	BTUH			
No Heater				2.8 *	4	15			2.8 *	4	15
BAYHTR1504BRK BAYHTR1504LUG	1/1	3.8	13100	16.0	24	25	2.9	9800	13.8	21	25
BAYHTR1505BRK BAYHTR1505LUG	1/1	4.8	16400	20.0	29	30	3.6	12300	17.3	25	25
BAYHTR1508BRK BAYHTR1508LUG	1/1	7.7	26200	32.0	44	45	5.8	19700	27.7	38	40
BAYHTR1510BRK BAYHTR1510LUG	1/1	9.6	32800	40.0	54	60	7.2	24600	34.6	47	50
BAYHTR1517BRK- Circuit 1 <sup>(a)</sup>	2/1	9.6	32800	40.0	54	60	7.2	24600	34.6	47	50
BAYHTR1517BRK- Circuit 2		4.8	16400	20.0	25	25	3.6	12300	17.3	22	25
BAYHTR3510LUG	1/3	9.6	32800	23.1	32	35	7.2	24600	20.0	28	30
BAYHTR3517LUG	1/3	14.4	49100	34.6	46	50	10.8	36900	30.0	41	45
BAYHTR1517BRK with single circuit power source kit BAYSPEKT201A	1/1	14.4	49100	60.0	83	90	10.8	36900	51.9	73	80

<sup>(a)</sup> MCA and MOP for circuit 1 contains the motor amps.

<b>TEM4A0C42S41SC</b>											
Heater Model No.	No. of Circuits/ Phases	240 Volt					208 Volt				
		Capacity		Heater Amps per Circuit	Minimum Circuit Ampacity	Maximum Overload Protection	Capacity		Heater Amps per Circuit	Minimum Circuit Ampacity	Maximum Overload Protection
		kW	BTUH				kW	BTUH			
No Heater				4.1 *	5	15			4.1 *	5	15
BAYHTR1504BRK BAYHTR1504LUG	1/1	3.84	13100	16.0	25	25	2.88	9800	13.8	22	25
BAYHTR1505BRK BAYHTR1505LUG	1/1	4.8	16400	20.0	30	30	3.6	12300	17.3	27	30
BAYHTR1508BRK BAYHTR1508LUG	1/1	7.68	26200	32.0	45	45	5.76	19700	27.7	40	40
BAYHTR1510BRK BAYHTR1510LUG	1/1	9.6	32800	40.0	55	60	7.2	24600	34.6	48	50
BAYHTR1517BRK- Circuit 1 <sup>(a)</sup>	2/1	9.6	32800	40.0	55	60	7.2	24600	34.6	48	50
BAYHTR1517BRK- Circuit 2		4.8	16400	20.0	25	25	3.6	12300	17.3	22	25
BAYHTR1523BRK- Circuit 1 <sup>(a)</sup>	2/1	9.6	32800	40.0	55	60	7.2	24600	34.6	48	50
BAYHTR1523BRK- Circuit 2		9.6	32800	40.0	50	50	7.2	24600	34.6	43	45
BAYHTR3510LUG	1/3	9.6	32800	23.1	33	35	7.2	24600	20.0	30	30
BAYHTR3517LUG	1/3	14.4	49200	34.6	48	50	10.8	36900	30.0	42	45



## Performance and Electrical Data

TEM4A0C42S41SC											
BAYHTR1517BRK with single circuit power source kit BAYSPEKT201A	1/1	14.4	49100	60.0	83	90	10.8	36900	51.9	73	80
BAYHTR1523BRK with single circuit power source kit BAYSPEKT201A	1/1	19.2	65500	80.0	108	110	14.4	49100	69.2	94	100

(a) MCA and MOP for circuit 1 contains the motor amps.

TEM4B0C37M31SA, TEM4A0C43M41SB											
Heater Model No.	No. of Circuits/ Phases	240 Volt					208 Volt				
		Capacity		Heater Amps per Circuit	Minimum Circuit Ampacity	Maximum Overload Protection	Capacity		Heater Amps per Circuit	Minimum Circuit Ampacity	Maximum Overload Protection
		kW	BTUH				kW	BTUH			
No Heater				4.1 *	5	15			4.1 *	5	15
BAYHTR1504BRK BAYHTR1504LUG	1/1	3.8	13100	16.0	25	25	2.9	9800	13.8	22	25
BAYHTR1505BRK BAYHTR1505LUG	1/1	4.8	16400	20.0	30	30	3.6	12300	17.3	27	30
BAYHTR1508BRK BAYHTR1508LUG	1/1	7.7	26200	32.0	45	45	5.8	19700	27.7	40	40
BAYHTR1510BRK BAYHTR1510LUG	1/1	9.6	32800	40.0	55	60	7.2	24600	34.6	48	50
BAYHTR1517BRK- Circuit 1 (a)	2/1	9.6	32800	40.0	55	60	7.2	24600	34.6	48	50
BAYHTR1517BRK- Circuit 2		4.8	16400	20.0	25	25	3.6	12300	17.3	22	25
BAYHTR1523BRK- Circuit 1 (a)	2/1	9.6	32800	40.0	55	60	7.2	24600	34.6	48	50
BAYHTR1523BRK- Circuit 2		9.6	32800	40.0	50	50	7.2	24600	34.6	43	45
BAYHTR3510LUG	1/3	9.6	32800	23.1	33	35	7.2	24600	20.0	30	30
BAYHTR3517LUG	1/3	14.4	49100	34.6	48	50	10.8	36900	30.0	42	45
BAYHTR1517BRK with single circuit power source kit BAYSPEKT201A	1/1	14.4	49100	60.0	83	90	10.8	36900	51.9	73	80
BAYHTR1523BRK with single circuit power source kit BAYSPEKT201A	1/1	19.2	65500	80.0	108	110	14.4	49100	69.2	94	100

(a) MCA and MOP for circuit 1 contains the motor amps.

TEM4A0C48S41SC											
Heater Model No.	No. of Circuits/ Phases	240 Volt					208 Volt				
		Capacity		Heater Amps per Circuit	Minimum Circuit Ampacity	Maximum Overload Protection	Capacity		Heater Amps per Circuit	Minimum Circuit Ampacity	Maximum Overload Protection
		kW	BTUH				kW	BTUH			
No Heater				6.0 *	8	15			6.0 *	8	15
BAYHTR1504BRK BAYHTR1504LUG	1/1	3.84	13100	16.0	28	30	2.88	9800	13.8	25	25
BAYHTR1505BRK BAYHTR1505LUG	1/1	4.8	16400	20.0	33	35	3.6	12300	17.3	29	30
BAYHTR1508BRK BAYHTR1508LUG	1/1	7.68	26200	32.0	48	50	5.76	19700	27.7	42	45
BAYHTR1510BRK BAYHTR1510LUG	1/1	9.6	32800	40.0	58	60	7.2	24600	34.6	51	60
BAYHTR1517BRK- Circuit 1 (a)	2/1	9.6	32800	40.0	58	60	7.2	24600	34.6	51	60
BAYHTR1517BRK- Circuit 2		4.8	16400	20.0	25	25	3.6	12300	17.3	22	25
BAYHTR1523BRK- Circuit 1 (a)	2/1	9.6	32800	40.0	58	60	7.2	24600	34.6	51	60
BAYHTR1523BRK- Circuit 2		9.6	32800	40.0	50	50	7.2	24600	34.6	43	45

## Performance and Electrical Data

TEM4A0C48S41SC											
BAYHTR1525BRK-Circuit 1 <sup>(a)</sup>	4/1	6.0	20500	25.0	39	40	4.5	15400	21.6	35	35
BAYHTR1525BRK-Circuit 2		6.0	20500	25.0	31	35	4.5	15400	21.6	27	30
BAYHTR1525BRK-Circuit 3		6.0	20500	25.0	31	35	4.5	15400	21.6	27	30
BAYHTR1525BRK-Circuit 4		6.0	20500	25.0	31	35	4.5	15400	21.6	27	30
BAYHTR3510LUG	1/3	9.6	32800	23.1	36	40	7.2	24600	20.0	32	35
BAYHTR3517LUG	1/3	14.4	49100	34.6	50	50	10.8	36900	30.0	44	45
BAYHTR1517BRK with single circuit power source kit BAYSPEKT201A	1/1	14.4	49100	60.0	83	90	10.8	36900	51.9	73	80
BAYHTR1523BRK with single circuit power source kit BAYSPEKT201A	1/1	19.2	65500	80.0	108	110	14.4	49100	69.2	94	100

<sup>(a)</sup> MCA and MOP for circuit 1 contains the motor amps.

TEM4A0C49M41SB, TEM4B0C60S51SA											
Heater Model No.	No. of Circuits/ Phases	240 Volt					208 Volt				
		Capacity		Heater Amps per Circuit	Minimum Circuit Ampacity	Maximum Overload Protection	Capacity		Heater Amps per Circuit	Minimum Circuit Ampacity	Maximum Overload Protection
		kW	BTUH				kW	BTUH			
No Heater				6.0 *	8	15			6.0 *	8	15
BAYHTR1504BRK BAYHTR1504LUG	1/1	3.8	13100	16.0	28	30	2.9	9800	13.8	25	25
BAYHTR1505BRK BAYHTR1505LUG	1/1	4.8	16400	20.0	33	35	3.6	12300	17.3	29	30
BAYHTR1508BRK BAYHTR1508LUG	1/1	7.7	26200	32.0	48	50	5.8	19700	27.7	42	45
BAYHTR1510BRK BAYHTR1510LUG	1/1	9.6	32800	40.0	58	60	7.2	24600	34.6	51	60
BAYHTR1517BRK-Circuit 1 <sup>(a)</sup>	2/1	9.6	32800	40.0	58	60	7.2	24600	34.6	51	60
BAYHTR1517BRK-Circuit 2		4.8	16400	20.0	25	25	3.6	12300	17.3	22	25
BAYHTR1523BRK-Circuit 1 <sup>(a)</sup>	2/1	9.6	32800	40.0	58	60	7.2	24600	34.6	51	60
BAYHTR1523BRK-Circuit 2		9.6	32800	40.0	50	50	7.2	24600	34.6	43	45
BAYHTR1525BRK-Circuit 1 <sup>(a)</sup>	4/1	6.0	20500	25.0	39	40	4.5	15400	21.6	35	35
BAYHTR1525BRK-Circuit 2		6.0	20500	25.0	31	35	4.5	15400	21.6	27	30
BAYHTR1525BRK-Circuit 3		6.0	20500	25.0	31	35	4.5	15400	21.6	27	30
BAYHTR1525BRK-Circuit 4		6.0	20500	25.0	31	35	4.5	15400	21.6	27	30
BAYHTR3510LUG	1/3	9.6	32800	23.1	36	40	7.2	24600	20.0	32	35
BAYHTR3517LUG	1/3	14.4	49100	34.6	50	50	10.8	36900	30.0	44	45
BAYHTR1517BRK with single circuit power source kit BAYSPEKT201A	1/1	14.4	49100	60.0	83	90	10.8	36900	51.9	73	80
BAYHTR1523BRK with single circuit power source kit BAYSPEKT201A	1/1	19.2	65500	80.0	108	110	14.4	49100	69.2	94	100

<sup>(a)</sup> MCA and MOP for circuit 1 contains the motor amps.

**Note:** \* = Motor Amps

# Electrical Data

Figure 1. Electrical Wiring Diagram (All models)

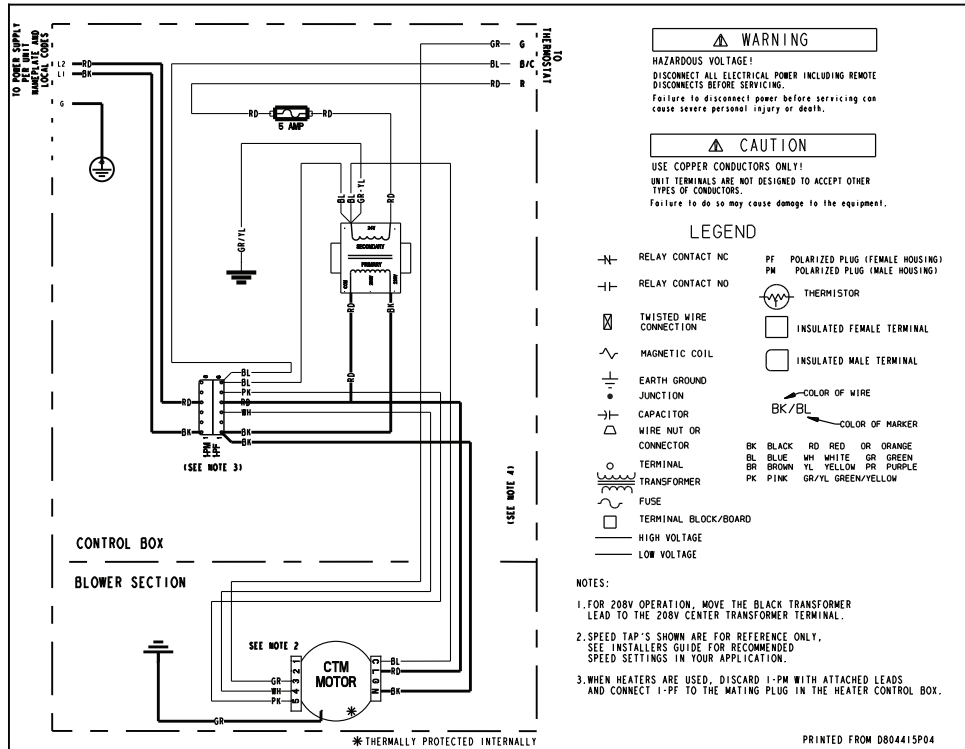

# Field Wiring

Figure 2. Field Wiring Diagrams

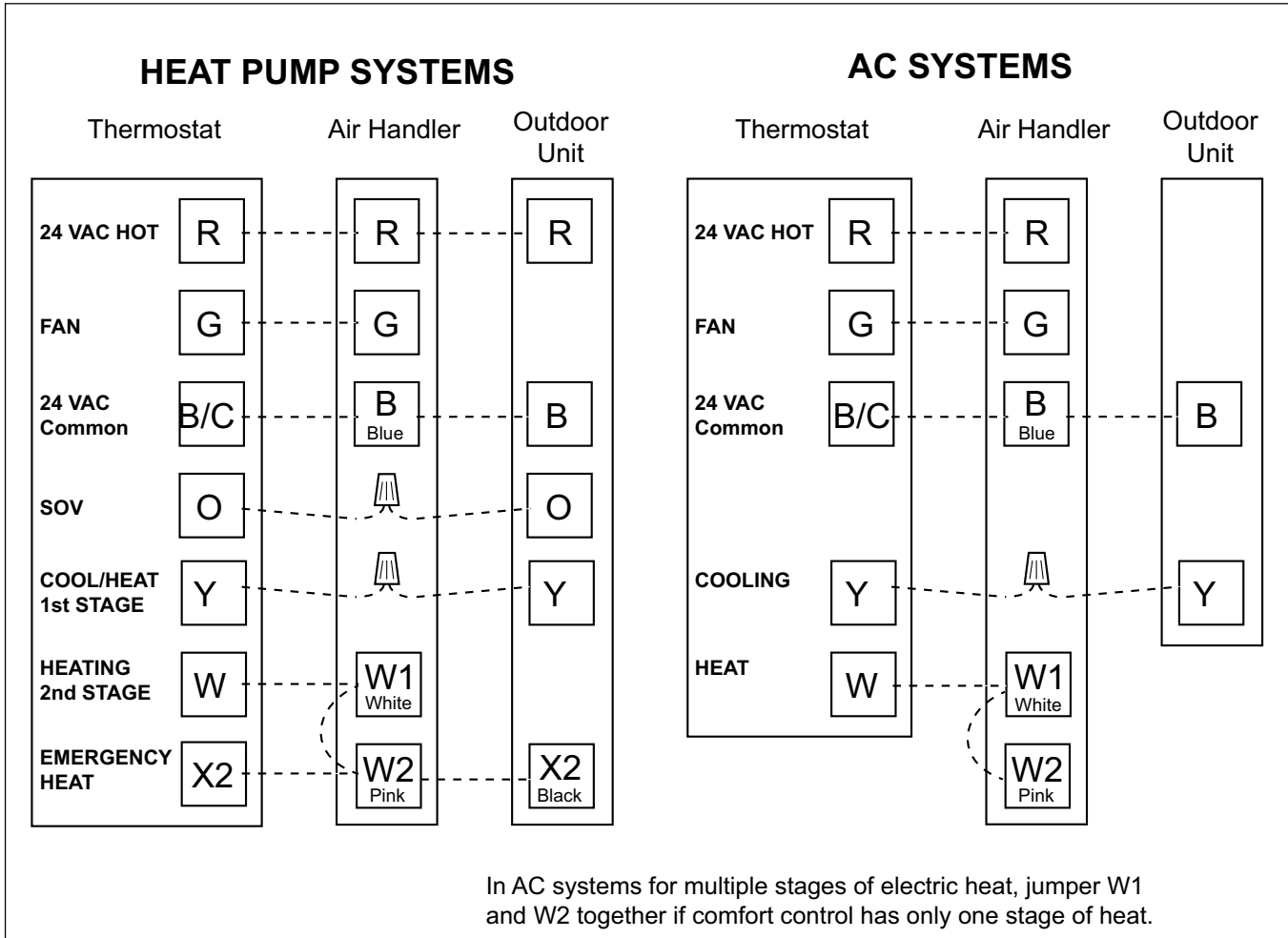

# TEM Convertibility

**Figure 3. Multi-Position Air Handler**  
 \* = No Internal Modifications Required.

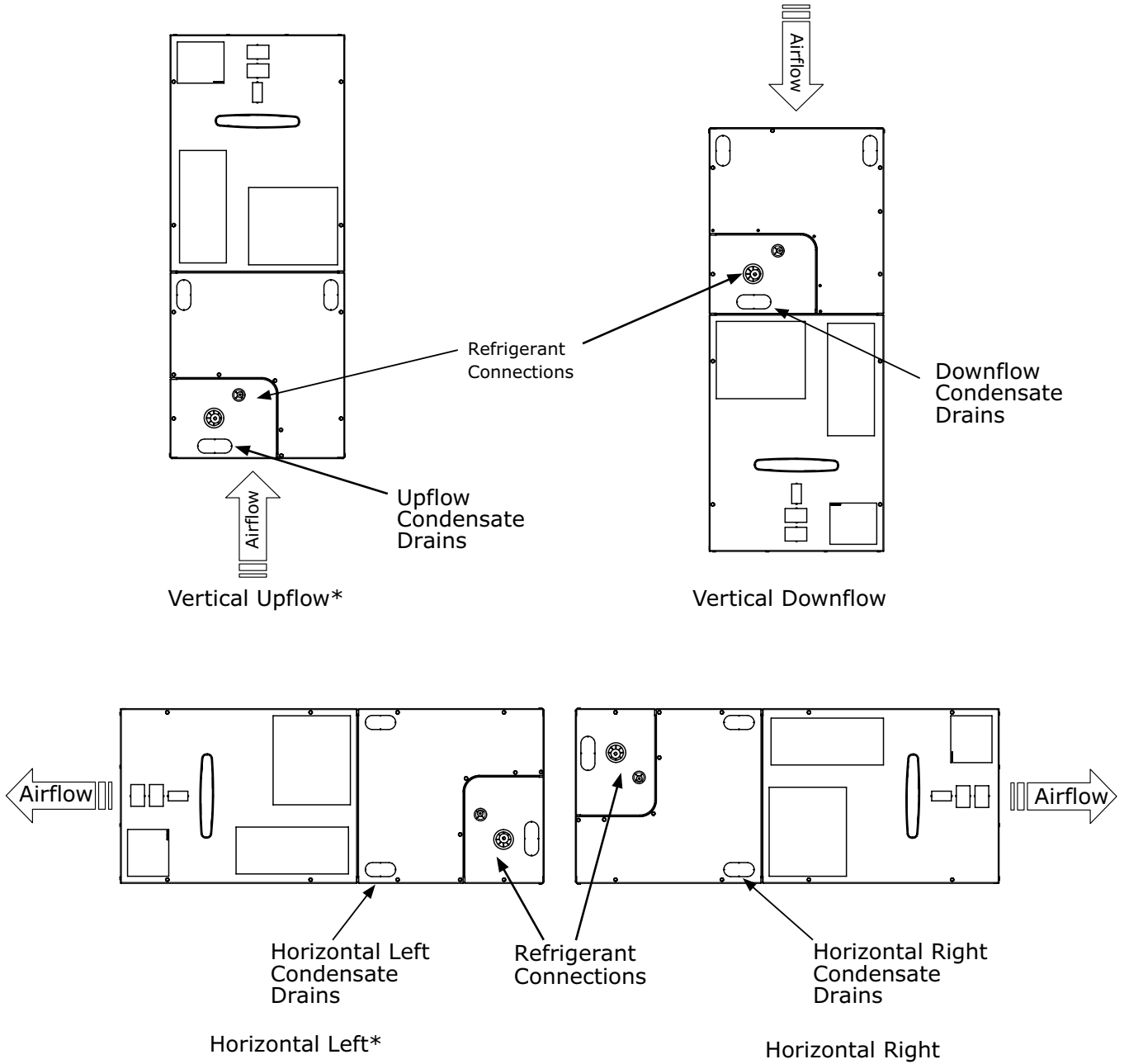





# TEM4 Air Handler Dimensional Data

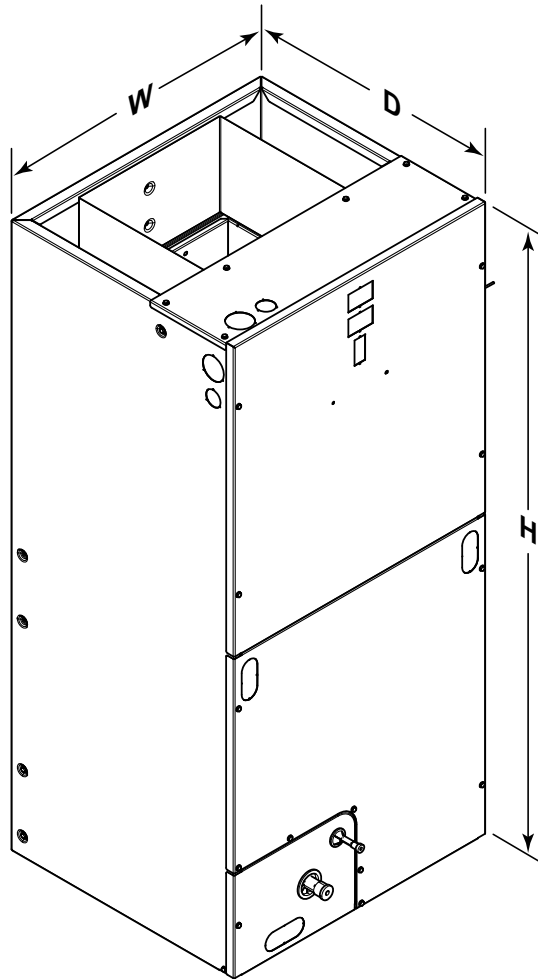

Model No.	H	W	D
TEM4B0B24M21SA	45.02	18.50	21.13
TEM4A0B31M31SB	46.77	18.50	21.13
TEM4A0C42S41SC	51.27	23.50	21.13
TEM4B0C37M31SA	51.27	23.50	21.13
TEM4A0C43M41SB	51.27	23.50	21.13
TEM4A0C48S41SC	51.27	23.50	21.13
TEM4A0C49M41SB	57.40	23.50	21.13
TEM4B0C60S51SA	57.40	23.50	21.13



# Outline Drawing

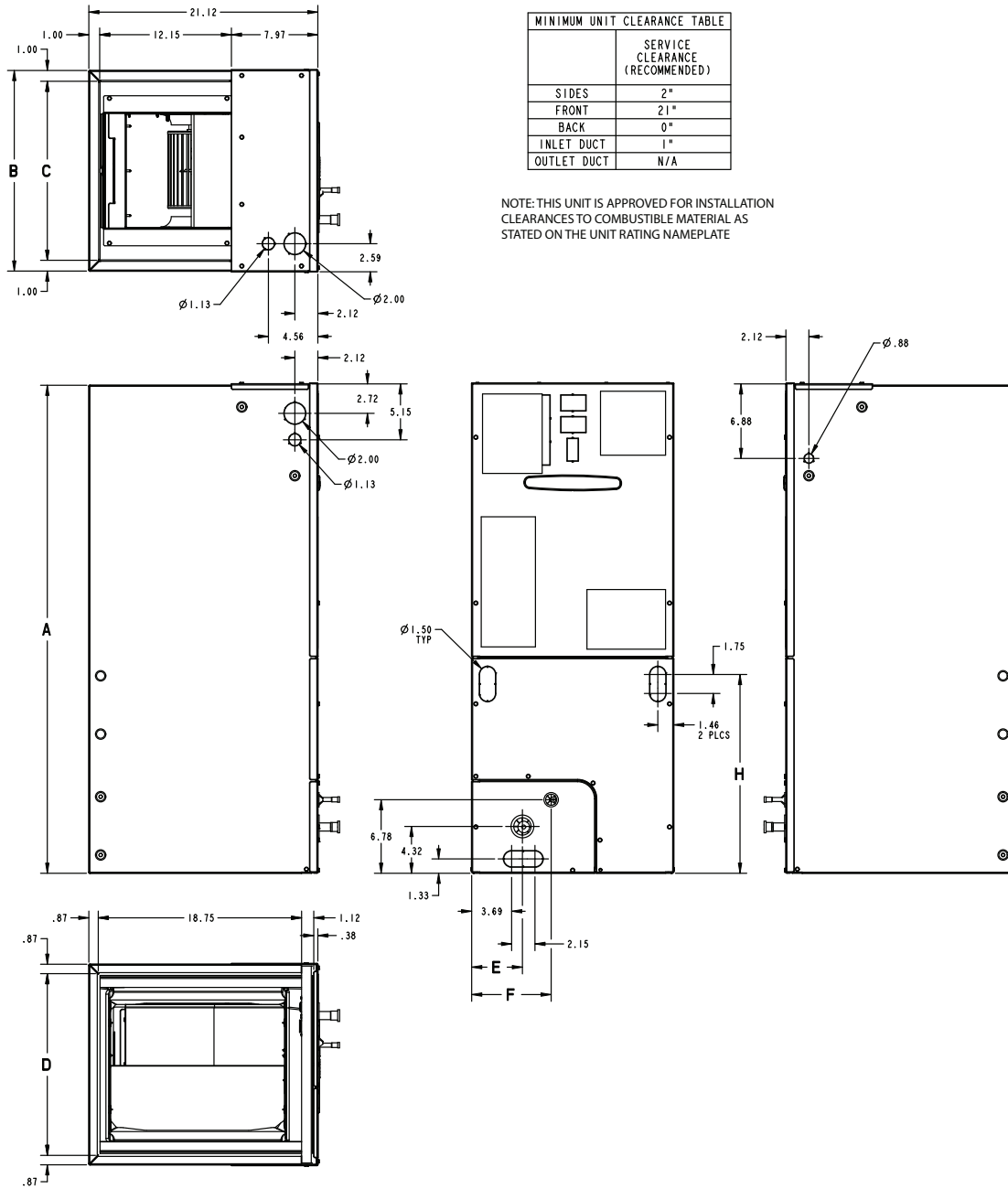

PRODUCT DIMENSIONS									
Air Handler Model	A	B	C	D	E	F	H	Flow Control	Gas Line Braze
TEM4B0B24	45.02	18.50	16.50	16.75	4.68	7.33	18.34	TXV	3/4
TEM4A0B31	46.77	18.50	16.50	16.75	4.68	7.33	20.09	TXV	3/4
TEM4B0C37, TEM4A0C42, 43, 48	51.27	23.50	21.50	21.75	7.01	9.66	24.59	TXV	7/8
TEM4A0C49, TEM4B0C60	57.40	23.50	21.50	21.75	4.68	9.66	27.19	TXV	7/8

All dimensions are in inches





Trane - by Trane Technologies (NYSE: TT), a global innovator - creates comfortable, energy efficient indoor environments for commercial and residential applications. For more information, please visit [trane.com](http://trane.com) or [tranetechnologies.com](http://tranetechnologies.com).

---



Trane has a policy of continuous data improvement and it reserves the right to change design and specifications without notice. We are committed to using environmentally conscious print practices.