

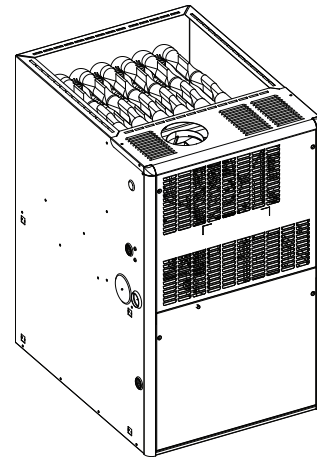

# Product Data

## Upflow / Horizontal Left/Right Single Stage Non-condensing Gas Fired Furnace

L8X1A055U3XSAB  
L8X1B070U4XSAB  
L8X1C100U5XSAB



*Note: Graphics in this document are for representation only. Actual model may differ in appearance.*



# General Features

## **NATURAL GAS MODELS**

L8X1 models are certified for installation in natural gas applications.

## **SAFE OPERATION**

Each component is tested at the manufacturing facility to help ensure consistent and reliable performance.

## **QUICK HEATING**

Tubular, aluminized steel heat exchanger transfers heat quickly and is composed of durable, heavy gauge steel.

## **INTEGRATED SYSTEM CONTROL**

Includes diagnostic lights for troubleshooting. All L8X1 models contain electronic air cleaner and humidifier connections.

## **ENERGY EFFICIENT OPERATION**

Furnace is certified to leak 2% or less of nominal air conditioning CFM delivered when pressurized to 0.5" water column with all inlets and outlets sealed.

When operating in natural gas, L8X1 models are certified by the SCAQMD and SJVAPC Districts to operate with NOx levels below 14 ng/J.

## **AIR DELIVERY**

The 5 speed constant torque blower motor helps deliver sufficient airflow in heating and cooling applications. The motor will switch from heating to cooling speeds on demand from the room thermostat.

## **STYLING**

The two-piece, louvered door increases combustion airflow and utilizes captured screws to make servicing easier.

## **FEATURES AND GENERAL OPERATION**

The L8X1 furnace utilizes a Silicon Nitride Hot Surface Ignition system which eliminates the waste of a constant burning pilot. The integrated system control lights the main burners upon a demand for heat from the room thermostat.



## Features and Benefits

### **80% AFUE on L8X1 FURNACE MODELS**

Lowers utility bills

### **ELECTRICALLY EFFICIENT**

Efficient airflow design reduces electrical energy use

### **34.5 INCH TALL**

Lighter, easier to move and fit into tight spaces like short basements or tight closets

Works great with larger, high-efficiency coils

### **3-WAY POISE**

Upflow/Horizontal Left/Horizontal Right

Each model offers 3 poises to help increase installation flexibility

### **AIRFLOW**

At least 350 CFM/ton at 0.5 in. H<sub>2</sub>O external static pressure

### **REGULATORY**

All models are certified to 2% or less air leakage

### **DIMENSIONS**

Widths are industry standard: 14.25", 17.5", 21"

Depth is approximately 28"

### **INTEGRATED FURNACE CONTROL**

Setup / Status / Diagnostics

EAC and HUM connections

Diagnostic lights to indicate fault codes

### **TUBULAR ALUMINIZED STEEL HEAT EXCHANGER**

### **ULTRA-LOW NOX OPERATION**

Models are certified to operate with NO<sub>x</sub> levels below 14 ng/J



# Accessories

**Table 1. Accessories**

<b>Model Number</b>	<b>Description</b>	<b>Use with</b>
BAYSPACER	6" Vertical Coil Spacer	L8X1A055 L8X1B070 L8X1C100
BAYSF1255BAA	1" SlimFit Filter Rack	All furnaces in side return. 17.5" cabinet in upflow orientations.
BAYBACKSPACER	Coil Off-set Bracket	L8X1A055 L8X1B070 L8X1C100



# Product Specifications

MODEL	L8X1A055U3XSAB	L8X1B070U4XSAB	L8X1C100U5XSAB
<b>TYPE</b>	Upflow / Horizontal	Upflow / Horizontal	Upflow / Horizontal
<b>RATINGS</b> (a)			
Input BTUH	55,000	70,000	100,000
Capacity BTUH (ICS) (b) (c)	44,000	56,000	80,000
Temp. Rise (Min.-Max.)	35 - 65	35 - 65	35 - 65
AFUE (%) (c)	80	80	80
<b>BLOWER DRIVE</b>			
Diameter — Width (In.)	11 X 6	11 X 8	11 X 10
No. Used	1	1	1
Speeds (No.)	5	5	5
CFM vs. in. w.g.	See Fan Performance Table	See Fan Performance Table	See Fan Performance Table
Motor HP	1/2	3/4	1
RPM	1050	1050	1050
Volts/Ph/Hz	120 / 1 / 60	120 / 1 / 60	120 / 1 / 60
FLA	6	8.4	11
<b>FILTER — Furnished?</b>	No	No	No
Size of filter recommended (bottom return)	14 x 25 x 1	16 x 25 x 1	20 x 25 x 1
Vent Pipe Diameter — Min (in.) (d)	4	4	4
<b>HEAT EXCHANGER</b>			
Type	Aluminized Steel	Aluminized Steel	Aluminized Steel
<b>ORIFICES — Main</b>			
Nat. Gas Qty. — Drill Size	1 - 3.4 mm	1 - #26	1 - #16
Gas Valve	Single Stage	Single Stage	Single Stage
Type	Hot Surface	Hot Surface	Hot Surface
<b>BURNERS — QTY</b>	1	1	1
<b>POWER CONN. — V/Ph/Hz</b> (e)	120 / 1 / 60	120 / 1 / 60	120 / 1 / 60
Ampacity (Amps)	8.73	11.60	14.85
Max. Overcurrent Protection (Amps)	15	20	25
<b>PIPE CONN. SIZE (in.)</b>	1/2 NPT	1/2 NPT	1/2 NPT
<b>DIMENSIONS</b>			
Uncrated (In.)	34.5 x 14.25 x 28	34.5 x 17.5 x 28	34.5 x 21 x 28
<b>WEIGHTS</b>			
Crated (lbs)	107	135	144
Uncrated (lbs)	96	123	130

(a) For U.S. applications, above input ratings (BTUH) are up to 2,000 feet, derate 4% per 1,000 feet for elevations above 2,000 feet above sea level.

(b) Central Furnace heating designs are certified to ANSI Z21.47 / CSA 2.3 — latest edition.

(c) Based on U.S. government standard tests.

(d) Refer to the Installer's Guide.

(e) The above wiring specifications are in accordance with National Electrical Code; however, installations must comply with local codes.



# Airflow Table

COOLING Airflow (CFM)										
Model Name/Heating Input	Return air via:	Motor Speed Tap	External Static Pressure (in. w.c.)							
			0.1	0.2	0.3	0.4	0.5	0.6	0.7	0.8
			CFM	CFM	CFM	CFM	CFM	CFM	CFM	CFM
L8X1A055U3XSAB 55,000 BTU/Hr	Bottom	5-High	1,180	1,140	1,110	1,080	1,050	1,015	985	955
		4-Med-High*	920	880	850	810	775	740	700	665
		3-Med-Low**	880	845	810	770	735	700	665	630
		2-Alternate	705	650	610	570	530	480	440	400
		1-Low***	640	600	555	510	470	430	390	340
	Side	5-High	1,160	1,125	1,095	1,065	1,040	1,010	975	945
		4-Med-High*	905	860	827	790	755	717	683	639
		3-Med-Low**	875	830	793	752	715	684	642	606
		2-Alternate	685	650	595	555	515	471	424	376
		1-Low***	640	585	540	500	460	415		

\* Factory Cooling Setting  
 \*\* Factory Heating Setting  
 \*\*\* Continuous Fan Speed

**Notes:**

1. Special consideration should be taken in duct design, evaporator coil selection/pressure drop, and air filter selection to achieve 350 CFM/ton at 0.5" external static pressure on the L8X1A055U3XSAB model.
2. To comply with government mandated efficiency standards, two openings are required for airflows above 1,600 CFM.
3. Data is shown without filter.

<b>COOLING Airflow (CFM)</b>										
<b>Model Name/ Heating Input</b>	<b>Return air via:</b>	<b>Motor Speed Tap</b>	<b>External Static Pressure (in. w.c.)</b>							
			<b>0.1</b>	<b>0.2</b>	<b>0.3</b>	<b>0.4</b>	<b>0.5</b>	<b>0.6</b>	<b>0.7</b>	<b>0.8</b>
			<b>CFM</b>	<b>CFM</b>	<b>CFM</b>	<b>CFM</b>	<b>CFM</b>	<b>CFM</b>	<b>CFM</b>	<b>CFM</b>
L8X1B070U4XSAB 70,000 BTU/Hr	Bottom	5 - High*	1,790	1,740	1,690	1,640	1,590	1,540	1,490	1,440
		4 - Alternate	1,650	1,590	1,560	1,500	1,450	1,400	1,350	1,290
		3 - Med-High	1,395	1,340	1,290	1,235	1,190	1,130	1,070	1,010
		2 - Med-Low**	820	1,070	1,010	960	890	820	770	720
		1 - Low***	1,160	730	630	570	540	490	430	380
	Side	5 - High*	1,740	1,700	1,660	1,610	1,550	1,510	1,460	1,400
		4 - Alternate	1,610	1,550	1,510	1,460	1,410	1,360	1,310	1,250
		3 - Med-High	1,350	1,295	1,245	1,185	1,140	1,085	1,035	985
		2 - Med-Low**	1,090	1,020	970	920	860	800	750	700
		1 - Low***	740	680	620	560	510	450	410	360
* Factory Cool Setting ** Factory Heat Setting *** Factory Fan Setting										

**Notes:**

1. To comply with government mandated efficiency standards, two openings are required for airflows above 1,600 CFM.
2. Data is shown without filter.



## Airflow Table

COOLING Airflow (CFM)										
Model Name/ Heating Input	Return air via:	Motor Speed Tap	External Static Pressure (in. w.c.)							
			0.1	0.2	0.3	0.4	0.5	0.6	0.7	0.8
			CFM	CFM	CFM	CFM	CFM	CFM	CFM	CFM
L8X1C100U5XSAB 100,00 BTU/Hr	Bottom	5 - High*	2,310	2,260	2,200	2,150	2,100	2,040	1,990	1,940
		4 - Med-High	1,870	1,820	1,760	1,720	1,670	1,610	1,560	1,490
		3 - Med-Low**	1,580	1,530	1,480	1,420	1,360	1,290	1,230	1,155
		2 - Alternate	1,500	1,450	1,400	1,340	1,280	1,210	1,130	1,050
		1 - Low***	1,390	1,320	1,260	1,200	1,130	1,060	970	890
	Side	5 - High*	2,160	2,100	2,060	2,020	2,050	1,990	1,950	1,880
		4 - Med-High	1,810	1,750	1,710	1,660	1,620	1,560	1,510	1,440
		3 - Med-Low**	1,540	1,490	1,440	1,380	1,330	1,270	1,210	1,150
		2 - Alternate	1,470	1,420	1,360	1,310	1,260	1,200	1,130	1,070
		1 - Low***	1,310	1,250	1,190	1,150	1,080	1,000	950	880
	Side + Bottom or 2 sides	5 - High*	2,280	2,220	2,170	2,120	2,090	2,080	2,020	1,950
		4 - Med-High	1,880	1,820	1,770	1,720	1,670	1,610	1,560	1,490
		3 - Med-Low**	1,600	1,530	1,460	1,400	1,340	1,270	1,200	1,120
		2 - Alternate	1,525	1,455	1,390	1,330	1,265	1,190	1,120	1,045
		1 - Low***	1,370	1,300	1,230	1,150	1,090	1,000	920	860

\* Factory Cool Setting  
 \*\* Factory Heat Setting  
 \*\*\* Factory Fan Setting

**Notes:**

1. To comply with government mandated efficiency standards, two openings are required for airflows above 1,600 CFM.
2. Data is shown without filter.



## CFM Versus Temperature Rise

HEATING Airflow (CFM) & Temperature Rise (°F)												
Model Name/ Heating Input	Return air via:	Motor Speed Tap	External Static Pressure (in. w.c.)									
			0.1		0.2		0.3		0.4		0.5	
			CFM	RISE	CFM	RISE	CFM	RISE	CFM	RISE	CFM	RISE
L8X1A055U3XSAB 55,000 BTU/Hr	Bottom	5-High										
		4-Med-High*										
		3-Med-Low**	880	46	845	48	810	50	770	53	735	55
		2-Alternate	705	58	650	63	610		570		530	
		1-Low***	640	64	600		555		510		470	
	Side	5-High										
		4-Med-High*										
		3-Med-Low**	874	47	831	49	793	51	752	54	715	57
		2-Alternate	684	60	650	63	595		553		514	
		1-Low***	640	64	585		540		500		460	

\* Factory Cooling Setting  
 \*\* Factory Heating Setting  
 \*\*\* Continuous Fan Speed

**Notes:**

1. Temperature rises in the table are approximate. Actual temperature rises may vary.
2. Individual cells shaded in gray indicate a temperature rise outside of the recommended range.
3. To comply with government mandated efficiency standards, speed settings shaded in gray are not allowed in HEAT mode.



## Airflow Table

HEATING Airflow (CFM) & Temperature Rise (°F)												
Model Name/ Heating Input	Return air via:	Motor Speed Tap	External Static Pressure (in. w.c.)									
			0.1		0.2		0.3		0.4		0.5	
			CFM	RISE	CFM	RISE	CFM	RISE	CFM	RISE	CFM	RISE
L8X1B070U4XSAB 70,000 BTU/Hr	Bottom	5 - High*										
		4 - Alternate										
		3 - Med-High										
		2 - Med-Low**	1,130	46	1,070	48	1,010	51	960	54	890	58
		1 - Low***	820	63	730		630		570		540	
	Side	5 - High*										
		4 - Alternate										
		3 - Med-High										
		2 - Med-Low**	1,090	48	1,020	51	970	53	920	56	860	60
		1 - Low***	740		680		620		560		510	

\* Factory Cool Setting  
 \*\* Factory Heat Setting  
 \*\*\* Factory Fan Setting

**Notes:**

1. Temperature rises in the table are approximate. Actual temperature rises may vary.
2. Individual cells shaded in gray indicate a temperature rise outside of the recommended range.
3. To comply with government mandated efficiency standards, speed settings shaded in gray are not allowed in HEAT mode.

HEATING Airflow (CFM) & Temperature Rise (°F)												
Model Name/ Heating Input	Return air via:	Motor Speed Tap	External Static Pressure (in. w.c.)									
			0.1		0.2		0.3		0.4		0.5	
			CFM	RISE	CFM	RISE	CFM	RISE	CFM	RISE	CFM	RISE
L8X1C100U5XSAB 100,00 BTU/Hr	Bottom	5 - High*										
		4 - Med-High										
		3 - Med-Low**	1,580	47	1,530	48	1,480	50	1,420	0	1,360	54
		2 - Alternate	1,500	49	1,450	51	1,400	53	1,340	55	1,280	58
		1 - Low***	1,390	53	1,320	56	1,260	59	1,200	62	1,130	
	Side	5 - High*										
		4 - Med-High										
		3 - Med-Low**	1,540	48	1,490	50	1,440	51	1,380	54	1,330	56
		2 - Alternate	1,470	50	1,420	52	1,360	54	1,310	57	1,260	59
		1 - Low***	1,310	57	1,250	59	1,190	62	1,150	64	1,080	
	Side + Bottom or 2 sides	5 - High*										
		4 - Med-High										
		3 - Med-Low**	1,600	46	1,530	48	1,460	51	1,400	53	1,340	55
		2 - Alternate	1,525	49	1,455	51	1,390	53	1,330	56	1,265	59
		1 - Low***	1,370	54	1,300	57	1,230	60	1,150	64	1,090	

\* Factory Cool Setting  
 \*\* Factory Heat Setting  
 \*\*\* Factory Fan Setting

**Notes:**

1. Temperature rises in the table are approximate. Actual temperature rises may vary.
2. Individual cells shaded in gray indicate a temperature rise outside of the recommended range.
3. To comply with government mandated efficiency standards, speed settings shaded in gray are not allowed in HEAT mode.

# Wiring Diagrams

Figure 1. Wiring Diagram

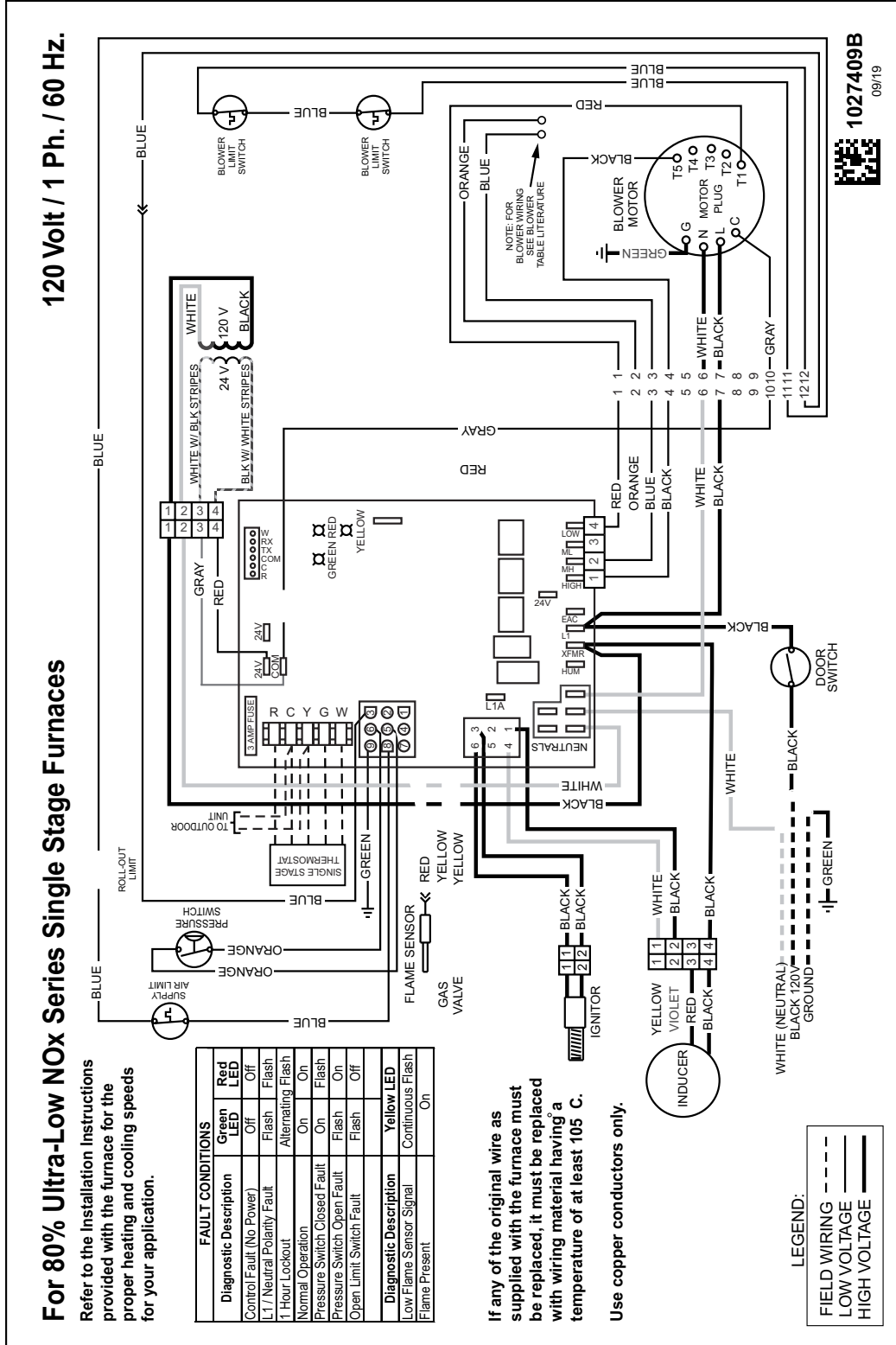



# Electrical Connections

Make wiring connections to the unit as indicated on enclosed wiring diagram. As with all gas appliances using electrical power, this furnace shall be connected into a permanently live electric circuit. It is recommended that furnace be provided with a separate "circuit protection device" electric circuit. The furnace must be electrically grounded in accordance with local codes or in the absence of local codes with the National Electrical Code, ANSI/NFPA 70, if an external electrical source is utilized. **The integrated furnace control is polarity sensitive.** The hot leg of the 120V power supply must be connected to the black power lead as indicated on the wiring diagram. Refer to the SERVICE FACTS literature and unit wiring diagram attached to furnace.

## Field Wiring

Figure 2. Field Wiring – Low Voltage Connections

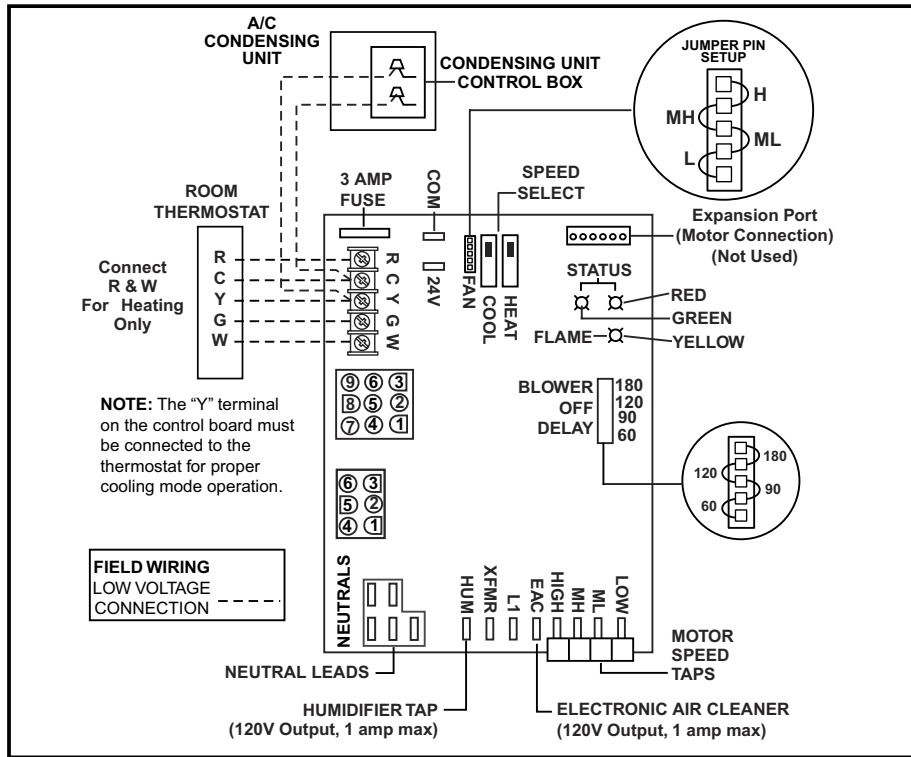

# Outline Drawing

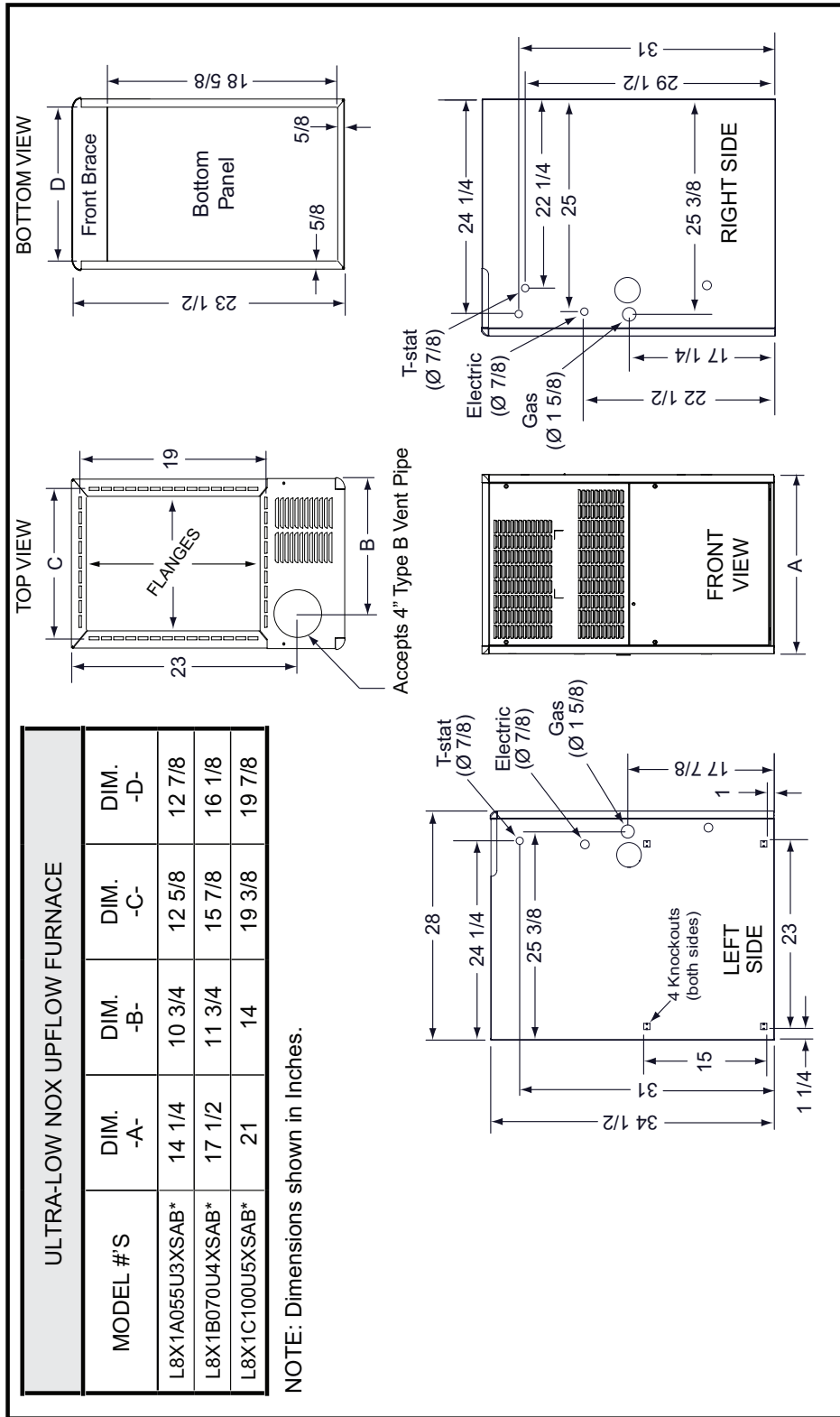





Trane - by Trane Technologies (NYSE: TT), a global innovator - creates comfortable, energy efficient indoor environments for commercial and residential applications. For more information, please visit [trane.com](http://trane.com) or [tranetechnologies.com](http://tranetechnologies.com).

---



Trane has a policy of continuous data improvement and it reserves the right to change design and specifications without notice. We are committed to using environmentally conscious print practices.