

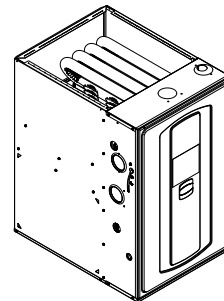

Product Data

Upflow / Horizontal Left/Right and Dedicated Downflow Single Stage Condensing Gas Fired Furnace

Upflow, Convertible to Horizontal Right or Horizontal Left, and Downflow
S9X1
S9B1



Note: Graphics in this document are for representation only. Actual model may differ in appearance.

⚠ WARNING

FIRE HAZARD!

Failure to follow this Warning could result in property damage, severe personal injury, or death.

This Warning applies to installations with a flammable refrigeration system. The furnace must be powered except for service. The furnace shall be installed and connected according to installation instructions and wiring diagrams that are provided with the evaporator coil.

⚠ CAUTION

COIL REQUIREMENT!

Failure to follow this Caution could result in property damage or personal injury. *GXC* and *MXC* coils installed on upflow furnaces in vertical, horizontal left, or horizontal right orientations without a factory installed metal drain pan shield must use a MAY*FERCOLKITAA kit. Coils installed on upflow furnaces must have drain pans that are suitable for 400° F (205°C) or have a metal drain pan shield. Downflow furnaces do not require a metal drain pan shield or the use of the MAY*FERCOLKITAA kit. See Installer's Guide for more information.



General Features

NATURAL GAS MODELS

Central Heating furnace designs are certified by the Intertek/ETL for both natural and Propane gas. Limit setting and rating data were established and approved under standard rating conditions using American National Standards Institute standards.

SAFE OPERATION

The Integrated Furnace Control is a solid state device which continuously monitors for presence of flame when the system is in the heating mode of operation. Dual solenoid combination gas valve and regulator provide additional safety.

QUICK HEATING

Durable, cycle tested, heavy gauge **tubular stainless steel primary heat exchanger** quickly transfers heat to provide warm conditioned air to the structure. **Low energy power vent blower**, to increase efficiency and provide a positive discharge of gas fumes to the outside.

BURNERS

Multiport Inshot burners will give years of quiet and efficient service. All models can be converted to **Propane** with Propane conversion kit.

INTEGRATED FURNACE CONTROL

Exclusively designed operational program provides total control of furnace limit sensors, blowers, gas valve, flame control and includes self diagnostics for ease of service. S9X1 also contains dry contacts for EAC and HUM.

ENERGY EFFICIENT OPERATION

S9X1 Furnace is certified by the manufacturer to leak 1% (1.4% for S9B1) or less of nominal air conditioning CFM delivered when pressurized to .5" water column with all inlets, outlets, and drains sealed.

AIR DELIVERY

The 9 tap constant torque ECM blower motor has sufficient airflow for most heating and cooling requirements and will switch from heating to cooling speeds on demand from room thermostat.

SECONDARY HEAT EXCHANGER

The S-Series furnace has a special type 29- 4C™ stainless steel secondary heat exchanger to reclaim heat from flue gases which would normally be lost.

STYLING

Heavy gauge steel and "wrap-around" cabinet construction is used in the cabinet with baked-on enamel finish for strength and beauty. Every orientation has at least two venting options. There are no knockouts on cabinet.

FEATURES AND GENERAL OPERATION

The S-Series furnace utilizes a Silicon Nitride Hot Surface Ignition system, which eliminates the waste of a constant burning pilot. The integrated furnace control lights the main burners upon a demand for heat from the room thermostat. Complete front service access.

- a. Low energy power venter
- b. Vent proving pressure switches.



Features and Benefits

UP TO 96.0% AFUE ON S9X1 FURNACE MODELS

Meets utility rebates

Lowers utility bills

ELECTRICALLY EFFICIENT

Efficient airflow design reduces electrical energy use

34 INCH TALL

Lighter, easier to move and fit into tight spaces like short basements or tight closets

Works great with larger, high-efficiency coils

No knockouts

3-WAY MULTI-POISE / DEDICATED DOWNFLOW

6 SKU's — Upflow / Horizontal Left / Horizontal Right

5 SKU's — Downflow

Added application flexibility and reduction in specification errors

AIRFLOW

At least 400 CFM/ton at 0.5 in. H₂O external static pressure

REGULATORY

All models are air tight; 1% or less air leakage as per ASHRAE 193 (1.4% for S9B1)

Open vestibule design provides a full 34" high open vestibule

DIMENSIONS

Width is industry standard: 17.5"

Width is industry standard: 21"

Width is industry standard: 24.5"

Depth remains approximately 28"

Cabinet is compatible with industry standard coils as well as other accessories

INTEGRATED FURNACE CONTROL

Setup / Status / Diagnostics / Digital Display

No dip switches

Last six errors stored

Dry contact EAC and HUM connections on S9X1 models

All multi-pin polarized terminals connections; no spade terminals

Low voltage labeled above and below

TUBULAR STAINLESS STEEL PRIMARY HEAT EXCHANGER

29-4C STAINLESS STEEL SECONDARY HEAT EXCHANGER

Stainless steel is a more durable, corrosive-resistant material than aluminumized steel

Integrated rail system for easy access if required

Reduces or eliminates need for baffles

VORTICA BLOWER, DESIGNED EXCLUSIVELY FOR THE S-SERIES FURNACE

Improved airflow efficiency

Durable, easy to clean, two piece housing

Single piece belly band/ motor arm assembly

Blower deck has full-length rails for easy removal and replacement, regardless of poise



Features and Benefits

THREE-WAY MULTI-POISE (UPFLOW, HORIZONTAL LEFT AND RIGHT) PLUS DEDICATED DOWNFLOW

Easier to specify

Shipped ready to install (no conversion kits required)

Every model has at least two venting options

Barbed fitting on trap at hose connection and on cabinet transition for hose has barbed fitting and clamps at both ends for leak resistance.

Vent table improvements including longer vent lengths.



Accessories

Table 1. Accessories

Model Number	Description	Use with
MAYBFERCOLKITA	Heat Shield Kit for B-width 4GXCB or 4MCXB Coils	B width 4GXCB or 4MCXB Coils when installed with Upflow Furnace in all orientations
MAYCFERCOLKITA	Heat Shield Kit for C-width 4GXCC or 4MCXC Coils	C-width 4GXCC or 4MCXC Coils when installed with Upflow Furnace in all orientations
MAYDFERCOLKITA	Heat Shield Kit for D-width 4GXCD or 4MCXD Coils	D width 4GXCD or 4MCXD Coils when installed with Upflow Furnace in all orientations
BAYHANG	Horizontal Hanging Kit	All Upflow Furnaces
BAYVENT200B	Sidewall Vent Termination Kit	All Furnaces
BAYVENTCN200B	Sidewall Vent Termination Kit (Canada —CPVC)	All Furnaces
BAYAIR30AVENTA	Concentric Vent Kit	All Furnaces
BAYAIR30CNVENT	Concentric Vent Kit (Canada — CPVC)	All Furnaces
BAYREDUCE	Reducing Coupling (CPVC)	All Furnaces
BAYLIFTB	Dual Return Kit (B size extension)	B Cabinet Upflow Furnaces
BAYLIFTC	Dual Return Kit (C size extension)	C Cabinet Upflow Furnaces
BAYLIFTD	Dual Return Kit (D size extension)	D Cabinet Upflow Furnaces
BAYBASE205	Downflow Subbase	All Downflow Furnaces
BAYFLTR203	Horizontal Filter Kit	B Cabinet Modular Blowers in Downflow/Horizontal
BAYFLTR204	Horizontal Filter Kit	C Cabinet Modular Blowers in Downflow/Horizontal
BAYFLTR205	Horizontal Filter Kit	D Cabinet Modular Blowers in Downflow/Horizontal
BAYFLTR206	Filter Access Door Kit (Downflow only)	All Downflow Furnaces
BAYSF1165*(a)	1" SlimFit Box with MERV 4 Filter	All Upflow Furnaces
BAYSF1255*	1" SlimFit Filter and Insulated Frame	All Furnaces (b)
BAYLPSS400*	Propane Conversion Kit with Stainless Steel Burners	All Furnaces
BAYBURNERSS	All Stainless Steel Natural Gas Burners - Set of Six	All Upflow Furnaces - Special Case
BAYMFGH200B	Manufactured/Mobile Housing Kit	All Furnaces
BAYCNDTRAP2A	Inline Condensate Trap Kit used with Special Venting on 2" Vent Pipe	All Furnaces
BAYCNDTRAP3A	Inline Condensate Trap Kit used with Special Venting on 3" Vent Pipe	All Furnaces
FLRSF1255	1" Filter replacement (Qty 12)	BAYSF1255*

(a) Airflow greater than 1600 CFM requires dual returns

(b) Designed to fit all S-Series furnaces with or without transition when used in side return. Fits B width cabinet without a transition in upflow/downflow applications.



Product Specifications

MODEL	S9X1B040U3PSBB (a) S9B1B040U3PSAB	S9X1B060U4PSBB (a) S9B1B060U4PSAB	S9X1B080U4PSBB (a) S9B1B080U4PSAB	S9X1C080U5PSBB (a) S9B1C080U5PSAB
TYPE	Upflow/Horizontal	Upflow/Horizontal	Upflow/Horizontal	Upflow/Horizontal
RATINGS (b)				
Input BTUH	40,000	60,000	80,000	80,000
Capacity BTUH (ICS) (c) (d)	39,000	58,300	77,200	77,800
Temp. Rise (Min.-Max.)	30 - 60	30 - 60	45 - 75	40 - 70
AFUE (%) S9X1 / S9B1(d)	96.0 / 92.1	96.0 / 92.1	96.0 / 92.1	96.0 / 92.1
Return Air Temp. (Min. - Max.)	45°F - 80°F	45°F - 80°F	45°F - 80°F	45°F - 80°F
BLOWER DRIVE	DIRECT	DIRECT	DIRECT	DIRECT
Diameter — Width (In.)	11 X 8	11 X 8	11 X 8	11 X 10
No. Used	1	1	1	1
Speeds (No.) (e)	9	9	9	9
CFM vs. in. w.g.	See Fan Performance Table	See Fan Performance Table	See Fan Performance Table	See Fan Performance Table
Motor HP	1/2	3/4	3/4	1
RPM	1075	1075	1075	1075
Volts/Ph/Hz	120 / 1 / 60	120 / 1 / 60	120 / 1 / 60	120 / 1 / 60
FLA	6.4	8.4	8.4	10.6
COMBUSTION FAN — Type	Centrifugal	Centrifugal	Centrifugal	Centrifugal
Drive — No. Speeds	Direct - 1	Direct - 1	Direct - 1	Direct - 1
Motor HP — RPM	3300	3300	3300	3300
Volts/Ph/Hz	120 / 1 / 60	120 / 1 / 60	120 / 1 / 60	120 / 1 / 60
FLA	2.14	2.14	2.14	0.66
FILTER — Furnished?	No	No	No	No
Type recommended	High Velocity	High Velocity	High Velocity	High Velocity
Hi Vel. (No.-Size-Thk.)	1 - 16 X 25 - 1 in.	1 - 16 X 25 - 1 in.	1 - 16 X 25 - 1 in.	1 - 20 X 25 - 1 in..
VENT PIPE DIAMETER — Min (in.) (f) (g)	2 Round	2 Round	2 Round	2 Round
HEAT EXCHANGER				
Type — Fired	409 Stainless Steel	409 Stainless Steel	409 Stainless Steel	409 Stainless Steel
— Unfired	29-4C Stainless Steel	29-4C Stainless Steel	29-4C Stainless Steel	29-4C Stainless Steel
Gauge (Fired)	20	20	20	20
ORIFICES — Main				
Nat. Gas Qty. — Drill Size	2- 45	3 - 45	4 - 45	4 - 45
Propane Gas Qty. — Drill Size	2- 56	3 - 56	4- 56	4- 56
GAS VALVE	Redundant - One Stage	Redundant - One Stage	Redundant - One Stage	Redundant - One Stage
PILOT SAFETY DEVICE				
Type	120 V SiNi Igniter	120 V SiNi Igniter	120 V SiNi Igniter	120 V SiNi Igniter
BURNERS — Type	Multiport Inshot	Multiport Inshot	Multiport Inshot	Multiport Inshot
Number	2	3	4	4

Product Specifications

MODEL	S9X1B040U3PSBB (a) S9B1B040U3PSAB	S9X1B060U4PSBB(a) S9B1B060U4PSAB	S9X1B080U4PSBB (a) S9B1B080U4PSAB	S9X1C080U5PSBB (a) S9B1C080U5PSAB
POWER CONN. — V/Ph/Hz (h)	120 / 1 / 60	120 / 1 / 60	120 / 1 / 60	120 / 1 / 60
Ampacity (In Amps)	10.3	12.8	12.8	14.1
Max. Overcurrent Protection (Amps)	15	15	15	15
PIPE CONN. SIZE (in.)	1/2	1/2	1/2	1/2
DIMENSIONS	H x W x D	H x W x D	H x W x D	H x W x D
Uncrated (In.)	34 x 17-1/2 x 28-3/4	34 x 17-1/2 x 28-3/4	34 x 17-1/2 x 28-3/4	34 x 21 x 28-3/4
Crated (In.)	35-1/2 x 19-1/2 x 30-7/8	35-1/2 x 19-1/2 x 30-7/8	35-1/2 x 19-1/2 x 30-7/8	35-1/2 x 23 x 30-7/8
WEIGHT				
Shipping (Lbs.)/Net (Lbs.)	122/114	130/122	135/127	149/139

(a) Meets Energy Star

(b) For U.S. applications, above input ratings (BTUH) are up to 2,000 feet, derate 4% per 1,000 feet for elevations above 2,000 feet above sea level. For Canadian applications, above input ratings (BTUH) are up to 4,500 feet, derate 4% per 1,000 feet for elevations above 4,500 feet above sea level.

(c) Central Furnace heating designs are certified to ANSI Z21.47 / CSA 2.3 — latest edition.

(d) Based on U.S. government standard tests.

(e) 9 Speed constant torque ECM blower motor

(f) Refer to the Vent Length Table in the Installer's Guide.

(g) All furnace models have a vent outlet diameter that equals 2 in.

(h) The above wiring specifications are in accordance with National Electrical Code; however, installations must comply with local codes.

MODEL	S9X1C100U5PSBB (a) S9B1C100U5PSAB	S9X1D120U5PSBB (a) S9B1D120U5PSAB	S9X1B040D3PSBB (a) S9B1B040D3PSAB	S9X1B060D3PSBB (a) S9B1B060D3PSAB
TYPE	Upflow / Horizontal	Upflow/Horizontal	Downflow	Downflow
RATINGS (b)				
Input BTUH	100,000	120,000	40,000	60,000
Capacity BTUH (ICS) (c) (d)	97,400	113,400	38,900	57,600
Temp. Rise (Min.-Max.)	40 - 70	40-70	30 - 60	35 - 65
AFUE (%) S9X1 / S9B1 (d)	95.0 / 92.1	95.0 / 92.1	96.0 / 92.1	96.0 / 92.1
Return Air Temp. (Min. - Max.)	45°F - 80°F	45°F - 80°F	45°F - 80°F	45°F - 80°F
BLOWER DRIVE	DIRECT	DIRECT	DIRECT	DIRECT
Diameter — Width (In.)	11 X 10	11 X 10	11 X 8	11 X 8
No. Used	1	1	1	1
Speeds (No.) (e)	9	9	9	9
CFM vs. in. w.g.	See Fan Performance Table	See Fan Performance Table	See Fan Performance Table	See Fan Performance Table
Motor HP	1	1	1/2	1/2
RPM	1075	1075	1075	1075
Volts/Ph/Hz	120 / 1 / 60	120 / 1 / 60	120 / 1 / 60	120 / 1 / 60
FLA	10.6	10.6	6.4	6.4
COMBUSTION FAN — Type	Centrifugal	Centrifugal	Centrifugal	Centrifugal
Drive — No. Speeds	Direct - 1	Direct - 1	Direct - 1	Direct - 1
Motor HP — RPM	3300	3300	3300	3300
Volts/Ph/Hz	120 / 1 / 60	120 / 1 / 60	120 / 1 / 60	120 / 1 / 60
FLA	0.66	0.66	2.14	2.14
FILTER — Furnished?	No	No	No	No
Type recommended	High Velocity	High Velocity	High Velocity	High Velocity
Hi Vel. (No.-Size-Thk.)	1 - 20 X 25 - 1 in.	1 - 24 X 25 - 1 in..	1 - 16 X 25 - 1 in.	1 - 16 X 25 - 1 in.



Product Specifications

MODEL	S9X1C100U5PSBB (a) S9B1C100U5PSAB	S9X1D120U5PSBB (a) S9B1D120U5PSAB	S9X1B040D3PSBB (a) S9B1B040D3PSAB	S9X1B060D3PSBB (a) S9B1B060D3PSAB
VENT PIPE DIAMETER — Min (in.) (f) (g)	2 Round	3 Round	2 Round	2 Round
HEAT EXCHANGER				
Type — Fired	409 Stainless Steel	409 Stainless Steel	409 Stainless Steel	409 Stainless Steel
— Unfired	29-4C Stainless Steel	29-4C Stainless Steel	29-4C Stainless Steel	29-4C Stainless Steel
Gauge (Fired)	20	20	20	20
ORIFICES — Main				
Nat. Gas Qty. — Drill Size	5 - 45	6 - 45	2 - 45	3 - 45
Propane Gas Qty. — Drill Size	5 - 56	6 - 56	2 - 56	3 - 56
GAS VALVE	Redundant - One Stage	Redundant - One Stage	Redundant - One Stage	Redundant - One Stage
PILOT SAFETY DEVICE				
Type	120 V SiNi Igniter	120 V SiNi Igniter	120 V SiNi Igniter	120 V SiNi Igniter
BURNERS — Type	Multiport Inshot	Multiport Inshot	Multiport Inshot	Multiport Inshot
Number	5	6	2	3
POWER CONN. — V/Ph/Hz (h)	120 / 1 / 60	120 / 1 / 60	120 / 1 / 60	120 / 1 / 60
Ampacity (In Amps)	13.3	14.1	10.3	10.3
Max. Overcurrent Protection (Amps)	15	15	15	15
PIPE CONN. SIZE (in.)	1/2	1/2	1/2	1/2
DIMENSIONS	H x W x D	H x W x D	H x W x D	H x W x D
Uncrated (In.)	34 x 21 x 28-3/4	34 x 24-1/2 x 28-3/4	34 x 17-1/2 x 28-3/4	34 x 17-1/2 x 28-3/4
Crated (In.)	35-1/2 x 23 x 30-7/8	35-1/2 x 26-1/2 x 30-7/8	35-1/2 x 19-1/2 x 30-7/8	35-1/2 x 19-1/2 x 30-7/8
WEIGHT				
Shipping (Lbs.)/Net (Lbs.)	155/145	167/156	122/114	127/119

(a) Meets Energy Star

(b) For U.S. applications, above input ratings (BTUH) are up to 2,000 feet, derate 4% per 1,000 feet for elevations above 2,000 feet above sea level. For Canadian applications, above input ratings (BTUH) are up to 4,500 feet, derate 4% per 1,000 feet for elevations above 4,500 feet above sea level.

(c) Central Furnace heating designs are certified to ANSI Z21.47 / CSA 2.3.

(d) Based on U.S. government standard tests.

(e) 9 Speed constant torque ECM blower motor

(f) Refer to the Vent Length Table in the Installer's Guide.

(g) All furnace models have a vent outlet diameter that equals 2 in.

(h) The above wiring specifications are in accordance with National Electrical Code; however, installations must comply with local codes.

MODEL	S9X1B080D4PSBB (a) S9B1B080D4PSAB	S9X1C100D5PSBB (a) S9B1C100D5PSAB	S9X1D120D5PSBB (a) S9B1D120D5PSAB
TYPE	Downflow	Downflow	Downflow
RATINGS (b)			
Input BTUH	80,000	100,000	120,000
Capacity BTUH (ICS) (c) (d)	76,900	96,800	115,500
Temp. Rise (Min.-Max.)	45 - 75	40 - 70	45-75
AFUE (%) S9X1 / S9B1 (d)	95.0 / 92.1	96.0 / 92.1	95.0 / 92.1
Return Air Temp. (Min. - Max.)	45°F - 80°F	45°F - 80°F	45°F - 80°F
BLOWER DRIVE	DIRECT	DIRECT	DIRECT
Diameter — Width (In.)	11 X 8	11 X 10	11 X 10
No. Used	1	1	1
Speeds (No.) (e)	9	9	9
CFM vs. in. w.g.	See Fan Performance Table	See Fan Performance Table	See Fan Performance Table

MODEL	S9X1B080D4PSBB (a) S9B1B080D4PSAB	S9X1C100D5PSBB (a) S9B1C100D5PSAB	S9X1D120D5PSBB (a) S9B1D120D5PSAB
Motor HP	3/4	1	1
RPM	1075	1075	1075
Volts/Ph/Hz	120 / 1 / 60	120 / 1 / 60	120 / 1 / 60
FLA	9.3	10.6	10.6
COMBUSTION FAN – Type	Centrifugal	Centrifugal	Centrifugal
Drive – No. Speeds	Direct - 1	Direct - 1	Direct - 1
Motor HP – RPM	3300	3300	3300
Volts/Ph/Hz	120 / 1 / 60	120 / 1 / 60	120 / 1 / 60
FLA	2.14	0.66	0.66
FILTER – Furnished?	No	No	No
Type recommended	High Velocity	High Velocity	High Velocity
Hi Vel. (No.-Size-Thk.)	1 - 16 X 25 - 1 in.	1 - 20 X 25 - 1 in.	1 - 24 X 25 - 1 in.
VENT PIPE DIAMETER – Min (in.) (f) (g)	2 Round	2 Round	3 Round
HEAT EXCHANGER			
Type – Fired	409 Stainless Steel	409 Stainless Steel	409 Stainless Steel
– Unfired	29-4C Stainless Steel	29-4C Stainless Steel	29-4C Stainless Steel
Gauge (Fired)	20	20	20
ORIFICES – Main			
Nat. Gas Qty. – Drill Size	4 - 45	5 - 45	6 - 45
Propane Gas Qty. – Drill Size	4- 56	5- 56	6- 56
GAS VALVE	Redundant - One Stage	Redundant - One Stage	Redundant - One Stage
PILOT SAFETY DEVICE			
Type	120 V SiNi Igniter	120 V SiNi Igniter	120 V SiNi Igniter
BURNERS – Type	Multiport Inshot	Multiport Inshot	Multiport Inshot
Number	4	5	6
POWER CONN. – V/Ph/Hz (h)	120 / 1 / 60	120 / 1 / 60	120 / 1 / 60
Ampacity (In Amps)	13.9	14.1	14.1
Max. Overcurrent Protection (Amps)	15	15	15
PIPE CONN. SIZE (in.)	1/2	1/2	1/2
DIMENSIONS	H x W x D	H x W x D	H x W x D
Uncrated (In.)	34 x 17-1/2 x 28-3/4	34 x 21 x 28-3/4	34 x 24-1/2 x 28-3/4
Crated (In.)	35-1/2 x 19-1/2 x 30-7/8	35-1/2 x 23 x 30-7/8	35-1/2 x 26-1/2 x 30-7/8
WEIGHT			
Shipping (Lbs.)/Net (Lbs.)	135/127	155/145	167/156

(a) Meets Energy Star

(b) For U.S. applications, above input ratings (BTUH) are up to 2,000 feet, derate 4% per 1,000 feet for elevations above 2,000 feet above sea level. For Canadian applications, above input ratings (BTUH) are up to 4,500 feet, derate 4% per 1,000 feet for elevations above 4,500 feet above sea level.

(c) Central Furnace heating designs are certified to ANSI Z21.47 / CSA 2.3.

(d) Based on U.S. government standard tests.

(e) 9 Speed constant torque ECM blower motor

(f) Refer to the Vent Length Table in the Installer's Guide.

(g) All furnace models have a vent outlet diameter that equals 2 in.

(h) The above wiring specifications are in accordance with National Electrical Code; however, installations must comply with local codes.

Airflow tables

Furnace Airflow (CFM) Vs. External Static Pressure (in. W.C.)							
Model	Tap		0.1	0.3	0.5	0.7	0.9
S9X1B040U3PSBB S9B1B040U3PSAB	1	SCFM	510	314	118	-	-
		Watts	34	43	52	-	-
	2	SCFM	532	341	150	-	-
		Watts	36	45	54	-	-
	3	SCFM	877	748	620	491	362
		Watts	91	104	118	131	144
	4	SCFM	933	813	693	573	452
		Watts	106	120	133	147	161
	5	SCFM	1056	950	843	737	631
		Watts	140	156	172	188	204
	6	SCFM	1111	1009	908	806	705
		Watts	157	174	190	207	223
	7	SCFM	1174	1078	983	887	791
		Watts	182	199	216	233	251
	8	SCFM	1376	1297	1218	1140	1061
		Watts	285	305	325	344	364
	9	SCFM	1512	1445	1378	1312	1245
		Watts	382	403	424	445	466

Furnace Airflow (CFM) Vs. External Static Pressure (in. W.C.)							
Model	Tap		0.1	0.3	0.5	0.7	0.9
S9X1B060U4PSBB S9B1B060U4PSAB	1	SCFM	840	702	565	427	290
		Watts	91	101	111	121	130
	2	SCFM	1001	893	786	678	571
		Watts	137	149	162	174	186
	3	SCFM	1140	1051	963	875	786
		Watts	193	207	221	235	249
	4	SCFM	1208	1128	1048	969	889
		Watts	223	238	253	268	283
	5	SCFM	1299	1224	1148	1073	998
		Watts	270	284	298	312	327
	6	SCFM	1413	1348	1283	1217	1152
		Watts	343	359	375	391	406
	7	SCFM	1444	1380	1315	1251	1186
		Watts	354	370	386	403	419
	8	SCFM	1727	1674	1622	1570	1518
		Watts	612	631	650	668	687
	9	SCFM	1790	1741	1691	1642	1593
		Watts	694	712	729	747	765

Furnace Airflow (CFM) Vs. External Static Pressure (in. W.C.)							
Model	Tap		0.1	0.3	0.5	0.7	0.9
S9X1B080U4PSBB S9B1B080U4PSAB	1	SCFM	911	766	622	477	332
		Watts	94	104	115	125	136
	2	SCFM	1075	963	851	740	628
		Watts	139	153	168	182	197
	3	SCFM	1215	1121	1028	934	840
		Watts	185	202	219	236	253
	4	SCFM	1250	1164	1077	990	903
		Watts	203	221	239	257	274
	5	SCFM	1349	1272	1194	1116	1039
		Watts	251	271	291	310	330
	6	SCFM	1453	1387	1321	1254	1188
		Watts	313	335	356	378	400
	7	SCFM	1505	1438	1372	1305	1239
		Watts	340	362	384	406	427
	8	SCFM	1657	1597	1538	1479	1419
		Watts	453	477	500	524	547
	9	SCFM	1878	1815	1752	1690	1627
		Watts	669	686	702	718	735

Furnace Airflow (CFM) Vs. External Static Pressure (in. W.C.)							
Model	Tap		0.1	0.3	0.5	0.7	0.9
S9X1C080U5PSBB S9B1C080U5PSAB	1	SCFM	643	384	125		
		Watts	45	53	62	-	-
	2	SCFM	1125	982	838	694	551
		Watts	126	142	158	174	190
	3	SCFM	1192	1038	884	730	576
		Watts	140	157	174	191	208
	4	SCFM	1509	1377	1246	1115	983
		Watts	245	268	291	314	337
	5	SCFM	1548	1428	1308	1187	1067
		Watts	257	281	304	328	352
	6	SCFM	1602	1467	1331	1196	1061
		Watts	320	345	371	396	421
	7	SCFM	1640	1512	1383	1255	1127
		Watts	352	379	406	433	459
	8	SCFM	1831	1778	1726	1673	1621
		Watts	521	550	579	608	637
	9	SCFM	2351	2278	2204	2131	2058
		Watts	886	918	950	982	1014



Airflow tables

Furnace Airflow (CFM) Vs. External Static Pressure (in. W.C.)							
Model	Tap		0.1	0.3	0.5	0.7	0.9
S9X1C100U5PSBB S9B1C100U5PSAB	1	SCFM	1013	847	680	514	348
		Watts	104	116	129	142	155
	2	SCFM	1261	1126	990	854	718
		Watts	168	185	202	219	236
	3	SCFM	1519	1407	1296	1184	1072
		Watts	267	290	313	336	358
	4	SCFM	1554	1446	1337	1229	1120
		Watts	283	307	330	353	377
	5	SCFM	1749	1651	1554	1457	1359
		Watts	385	411	436	462	488
	6	SCFM	1868	1778	1688	1599	1509
		Watts	464	491	519	546	574
	7	SCFM	2018	1936	1853	1770	1688
		Watts	573	602	631	660	689
	8	SCFM	2191	2112	2033	1954	1875
		Watts	718	750	782	815	847
	9	SCFM	2395	2303	2212	2120	2028
		Watts	966	981	996	1012	1027

Furnace Airflow (CFM) Vs. External Static Pressure (in. W.C.)							
Model	Tap		0.1	0.3	0.5	0.7	0.9
S9X1D120U5PSBB S9B1D120U5PSAB	1	SCFM	707	443	179	-	-
		Watts	46	55	64	-	-
	2	SCFM	1344	1218	1092	966	840
		Watts	163	183	202	222	241
	3	SCFM	1532	1419	1307	1195	1083
		Watts	225	247	268	290	312
	4	SCFM	1584	1477	1370	1263	1156
		Watts	247	270	292	315	338
	5	SCFM	1915	1818	1722	1625	1529
		Watts	401	428	454	480	506
	6	SCFM	2104	2016	1927	1839	1750
		Watts	525	553	582	610	639
	7	SCFM	2132	2045	1958	1870	1783
		Watts	546	575	604	633	662
	8	SCFM	2410	2328	2247	2165	2084
		Watts	833	868	903	937	972
	9	SCFM	2472	2401	2329	2257	2186
		Watts	909	944	979	1013	1048

Furnace Airflow (CFM) Vs. External Static Pressure (in. W.C.)							
Model	Tap		0.1	0.3	0.5	0.7	0.9
S9X1B040D3PSBB S9B1B040D3PSAB	1	SCFM	378	153	-	-	-
		Watts	28	32	-	-	-
	2	SCFM	514	330	145	-	-
		Watts	35	45	55	64	74
	3	SCFM	765	618	471	324	178
		Watts	69	81	93	105	116
	4	SCFM	827	691	554	418	281
		Watts	81	94	106	119	132
	5	SCFM	988	879	770	661	553
		Watts	124	140	156	171	187
	6	SCFM	1085	986	887	787	688
		Watts	156	173	190	207	224
	7	SCFM	1125	1030	934	839	743
		Watts	170	188	205	222	239
	8	SCFM	1129	1035	941	847	753
		Watts	170	187	204	221	239
	9	SCFM	1492	1419	1346	1273	1200
		Watts	369	390	411	431	452

Furnace Airflow (CFM) Vs. External Static Pressure (in. W.C.)							
Model	Tap		0.1	0.3	0.5	0.7	0.9
S9X1B060D3PSBB S9B1B060D3PSAB	1	SCFM	624	451	277	104	-
		Watts	47	57	68	79	-
	2	SCFM	866	734	602	470	338
		Watts	89	102	116	129	142
	3	SCFM	949	833	718	602	486
		Watts	113	128	142	156	171
	4	SCFM	1122	1025	928	831	733
		Watts	165	182	200	217	235
	5	SCFM	1178	1087	996	905	814
		Watts	191	209	227	246	264
	6	SCFM	1260	1180	1100	1021	941
		Watts	233	252	271	290	309
	7	SCFM	1370	1299	1228	1158	1087
		Watts	296	316	336	355	375
	8	SCFM	1480	1416	1352	1287	1223
		Watts	365	387	408	429	450
	9	SCFM	1504	1440	1376	1312	1249
		Watts	384	406	427	449	470



Airflow tables

Furnace Airflow (CFM) Vs. External Static Pressure (in. W.C.)							
Model	Tap		0.1	0.3	0.5	0.7	0.9
S9X1B080D4PSBB S9B1B080D4PSAB	1	SCFM	499	306	113	-	-
		Watts	36	43	49	-	-
	2	SCFM	1017	922	828	734	640
		Watts	143	158	173	188	203
	3	SCFM	1119	1029	940	850	761
		Watts	176	192	207	223	239
	4	SCFM	1205	1125	1044	964	883
		Watts	215	233	250	268	285
	5	SCFM	1237	1160	1083	1006	928
		Watts	231	250	268	286	305
	6	SCFM	1378	1309	1240	1172	1103
		Watts	315	334	354	373	393
	7	SCFM	1453	1389	1324	1260	1195
		Watts	360	380	399	419	439
	8	SCFM	1618	1562	1505	1449	1392
		Watts	496	518	540	561	583
	9	SCFM	1794	1742	1691	1639	1587
		Watts	682	704	726	748	770

Furnace Airflow (CFM) Vs. External Static Pressure (in. W.C.)							
Model	Tap		0.1	0.3	0.5	0.7	0.9
S9X1C100D5PSBB S9B1C100D5PSAB	1	SCFM	1002	823	644	465	285
		Watts	103	117	130	144	157
	2	SCFM	1385	1276	1167	1057	948
		Watts	223	243	264	284	304
	3	SCFM	1527	1430	1333	1236	1139
		Watts	286	310	333	357	380
	4	SCFM	1610	1516	1421	1326	1231
		Watts	328	352	377	401	425
	5	SCFM	1761	1677	1593	1509	1425
		Watts	433	459	486	512	538
	6	SCFM	1861	1783	1706	1628	1551
		Watts	492	520	549	577	605
	7	SCFM	1984	1902	1820	1738	1656
		Watts	548	577	606	635	663
	8	SCFM	2173	2097	2020	1944	1867
		Watts	728	760	792	824	856
	9	SCFM	2342	2269	2196	2123	2050
		Watts	945	973	1002	1031	1060

Furnace Airflow (CFM) Vs. External Static Pressure (in. W.C.)							
Model	Tap		0.1	0.3	0.5	0.7	0.9
S9X1D120D5PSBB S9B1D120D5PSAB	1	SCFM	680	419	159	-	-
		Watts	47	56	66	-	-
	2	SCFM	1025	1063	1101	1139	1177
		Watts	237	259	282	304	327
	3	SCFM	1566	1461	1357	1253	1149
		Watts	268	292	316	340	363
	4	SCFM	1803	1711	1619	1527	1435
		Watts	393	420	446	472	498
	5	SCFM	1891	1801	1711	1621	1532
		Watts	445	472	500	527	555
	6	SCFM	2132	2025	1919	1812	1705
		Watts	568	601	633	666	698
	7	SCFM	2154	2068	1982	1896	1810
		Watts	644	675	705	736	766
	8	SCFM	2344	2267	2190	2113	2035
		Watts	837	870	902	934	967
	9	SCFM	2414	2333	2251	2170	2088
		Watts	896	928	961	993	1026



CFM Versus Temperature Rise S9X1 PD

Table 2. Heating Table – Upflow

CFM VS. TEMPERATURE RISE																	
MODEL																	
	700	800	900	1000	1100	1200	1300	1400	1500	1600	1700	1800	1900	2000	2100	2200	2300
S9X1B040U3PSBB S9B1B040U3PSAB	55	48	44	39	36	33	30										
S9X1B060U4PSBB S9B1B060U4PSAB			63	58	52	49	46	43	41	40							
S9X1B080U4PSBB S9B1B080U4PSAB			71	68	64	61	57	54	51	48	45						
S9X1C080U5PSBB S9B1C080U5PSAB				68	65	59	56	54	49	46	44						
S9X1C100U5PSBB S9B1C100U5PSAB								68	65	61	57	55	53	49	46		
S9X1D120U5PSBB S9B1D120U5PSAB									67	65	60	55	54	51	48	44	41

Table 3. Heating Table – Downflow

CFM VS. TEMPERATURE RISE																			
MODEL	CFM (CUBIC FEET PER MINUTE)																		
	500	600	700	800	900	1000	1100	1200	1300	1400	1500	1600	1700	1800	1900	2000	2100	2200	2300
S9X1B040D3PSBB S9B1B040D3PSAB	57	53	46	45	37	34	31												
S9X1B060D3PSBB S9B1B060D3PSAB					63	58	52	48	44	41									
S9X1B080D4PSBB S9B1B080D4PSAB					72	69	65	62	57	53	49	48							
S9X1C100D5PSBB S9B1C100D5PSAB								68	65	62	58	55	53	50	48	44			
S9X1D120D5PSBB S9B1D120D5PSAB									72	69	66	64	58	56	53	52	49	44	

Wiring Diagram

Figure 1. S9X1 Wiring Diagram

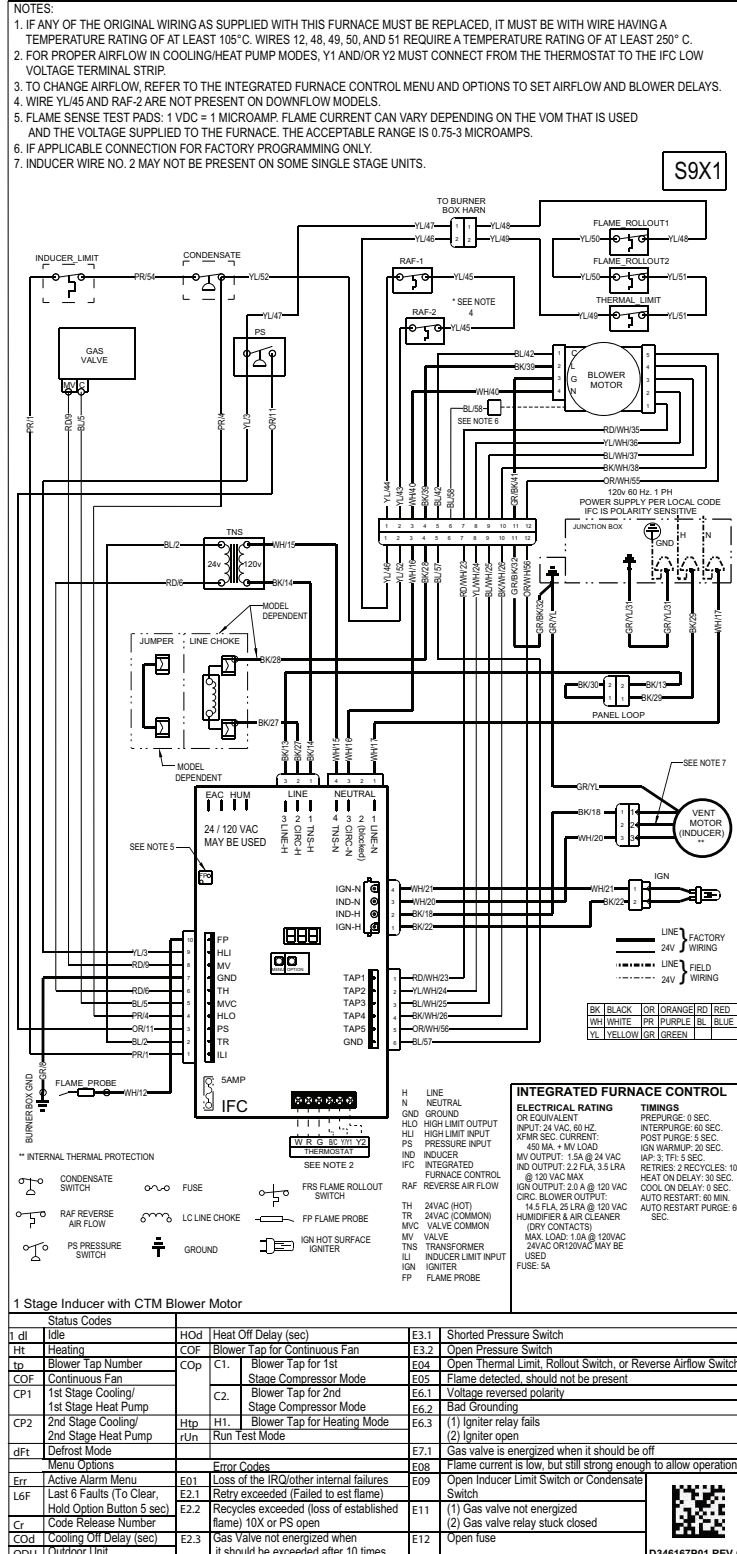

Figure 2. S9X1 Ladder Diagram

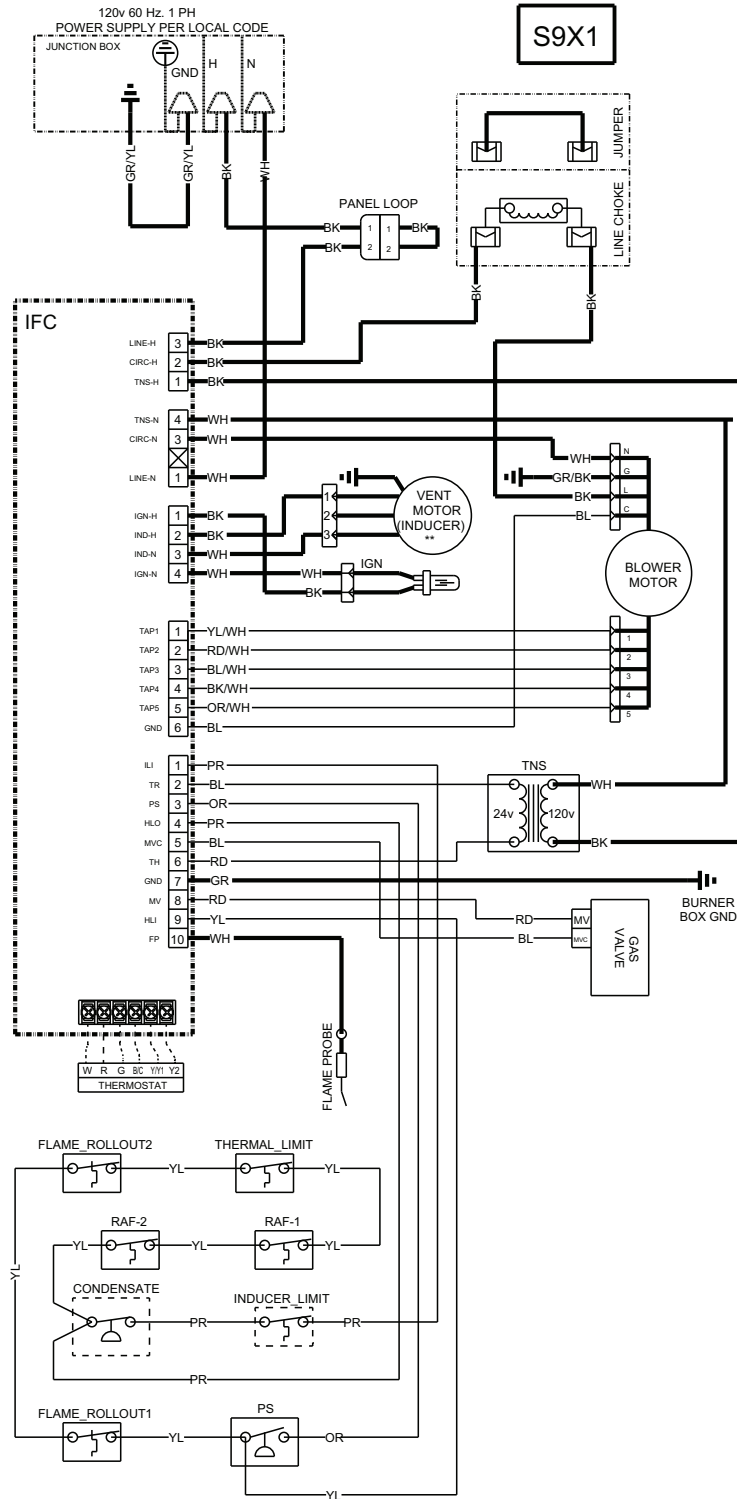

Figure 3. S9B1 Wiring Diagram

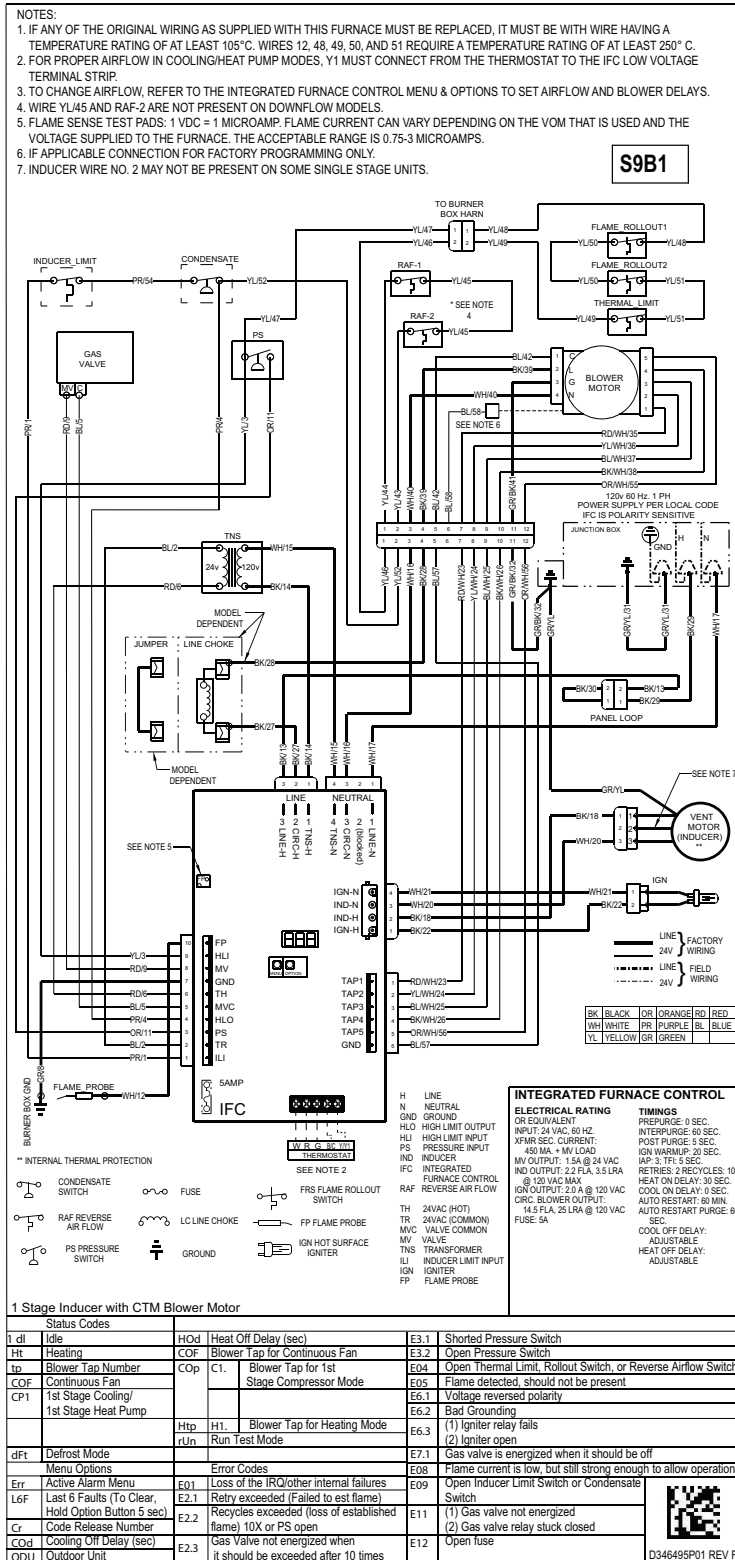
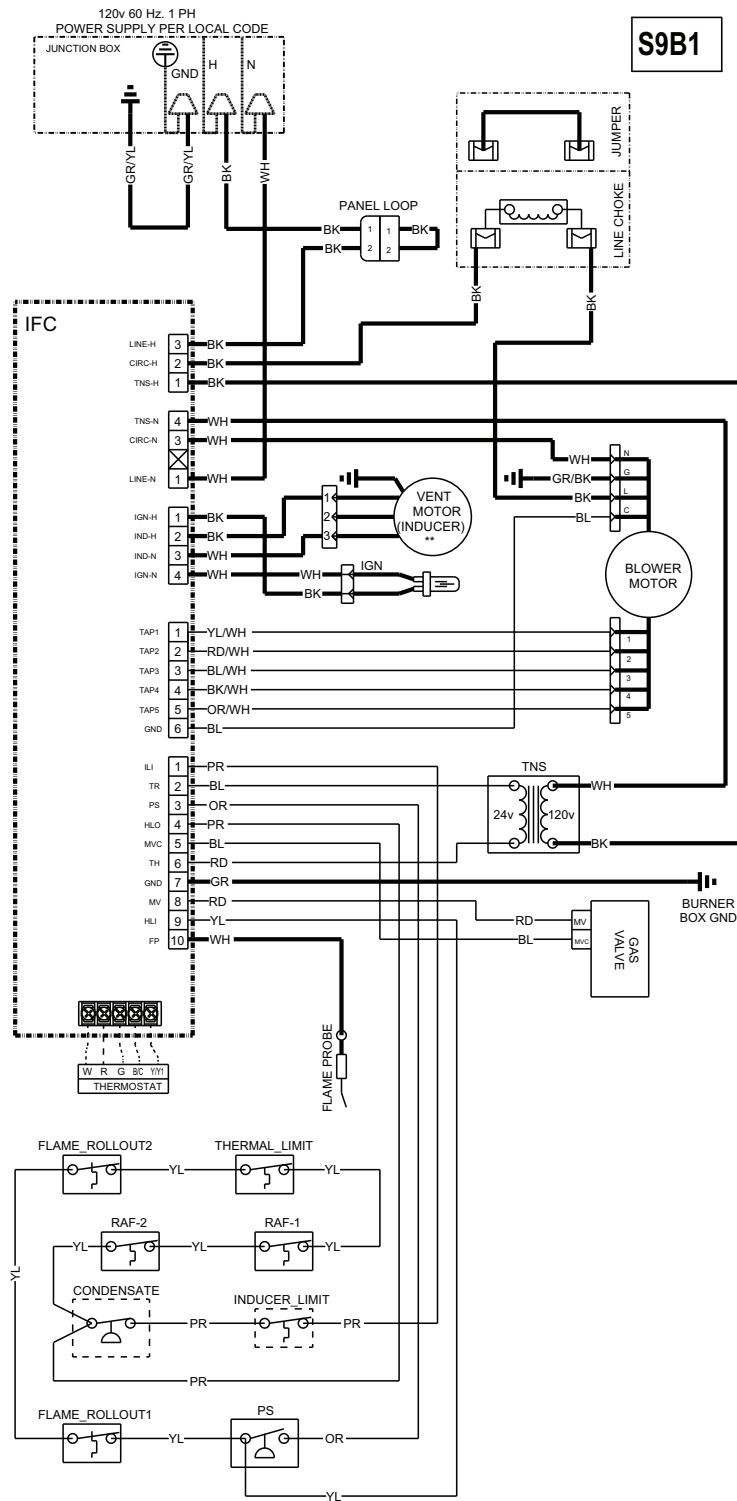

Figure 4. S9B1 Ladder Diagram





Electrical Connections

Make wiring connections to the unit as indicated on enclosed wiring diagram. As with all gas appliances using electrical power, this furnace shall be connected into a permanently live electric circuit. It is recommended that furnace be provided with a separate "circuit protection device" electric circuit. The furnace must be electrically grounded in accordance with local codes or in the absence of local codes with the National Electrical Code, ANSI/NFPA 70, if an external electrical source is utilized. **The integrated furnace control is polarity sensitive.** The hot leg of the 120V power supply must be connected to the black power lead as indicated on the wiring diagram. Refer to the Wiring Diagram section in this document and unit wiring diagram attached to furnace.

⚠ WARNING

FIRE HAZARD!
 Failure to follow this Warning could result in property damage, severe personal injury, or death.
 This Warning applies to installations with a flammable refrigeration system. The furnace must be powered except for service. The furnace shall be installed and connected according to installation instructions and wiring diagrams that are provided with the evaporator coil.

Field Wiring

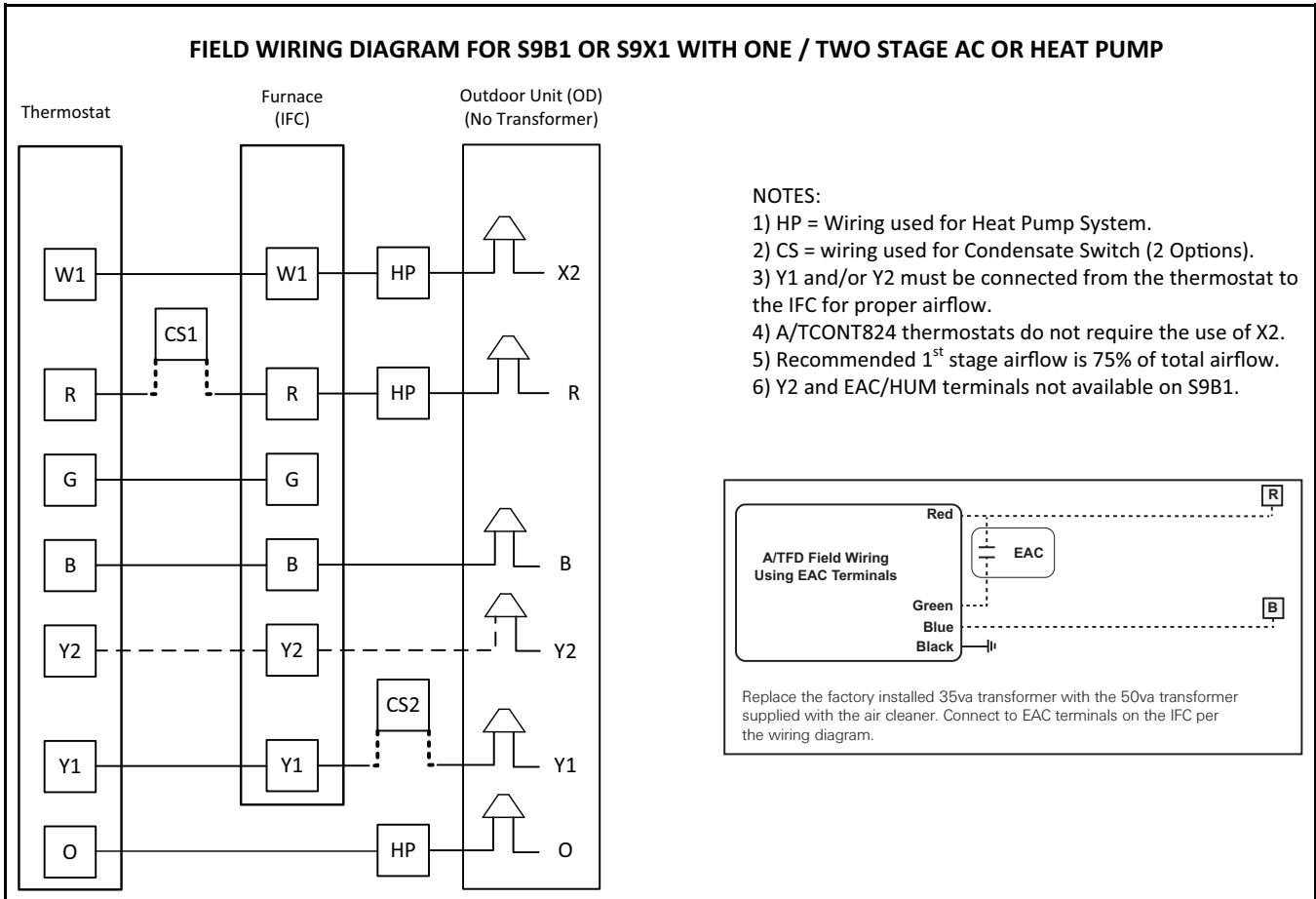

FIELD WIRING DIAGRAM FOR S9X1 WITH SINGLE STAGE AC OR HEAT PUMP WITH 2 STAGE AIRFLOW

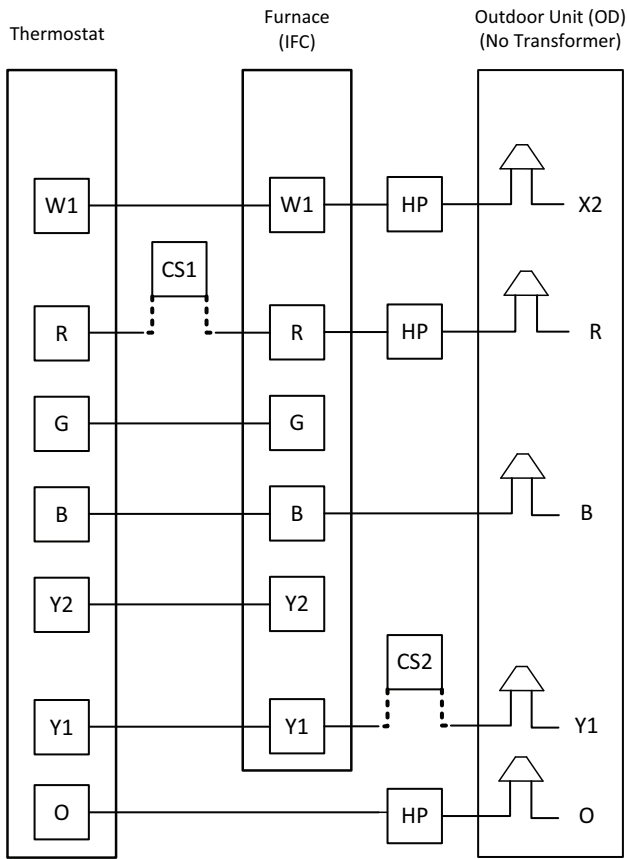

NOTES:

- 1) HP = Wiring used for Heat Pump System.
- 2) CS = wiring used for Condensate Switch (2 Options).
- 3) Y1 and Y2 must be connected from the thermostat to the IFC for proper airflow.
- 4) Thermostat must be setup for 2 stage OD.
- 5) IFC Must be setup for 2 stage OD using the Menu/Option Buttons.
- 6) Recommended 1st stage airflow is 75% of total airflow.
- 7) A/TCONT824 thermostats do not require the use of X2.

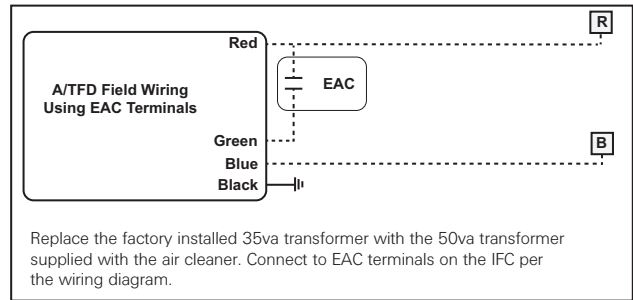



Outline Drawings

Table 5. 21" Upflow Cabinet

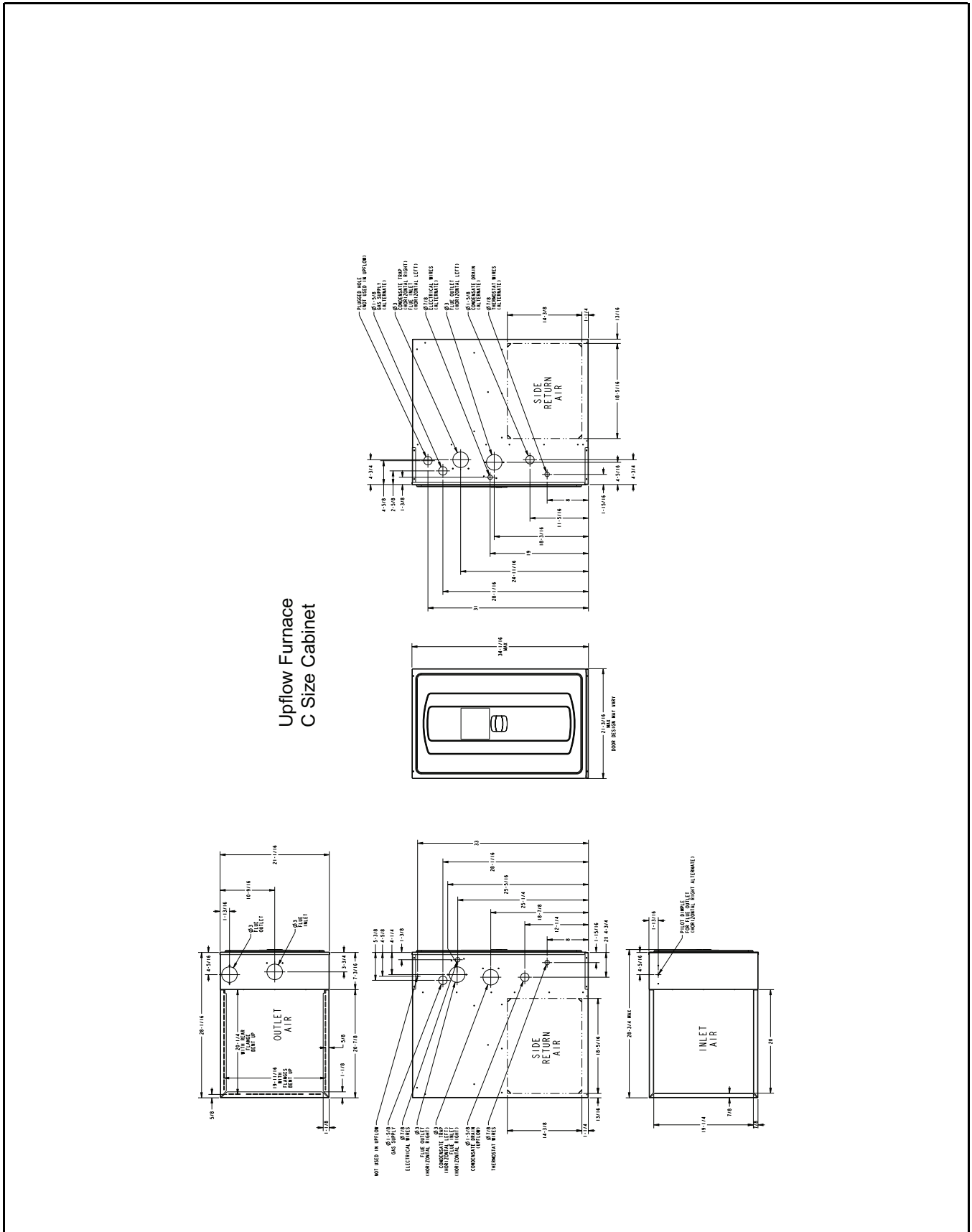
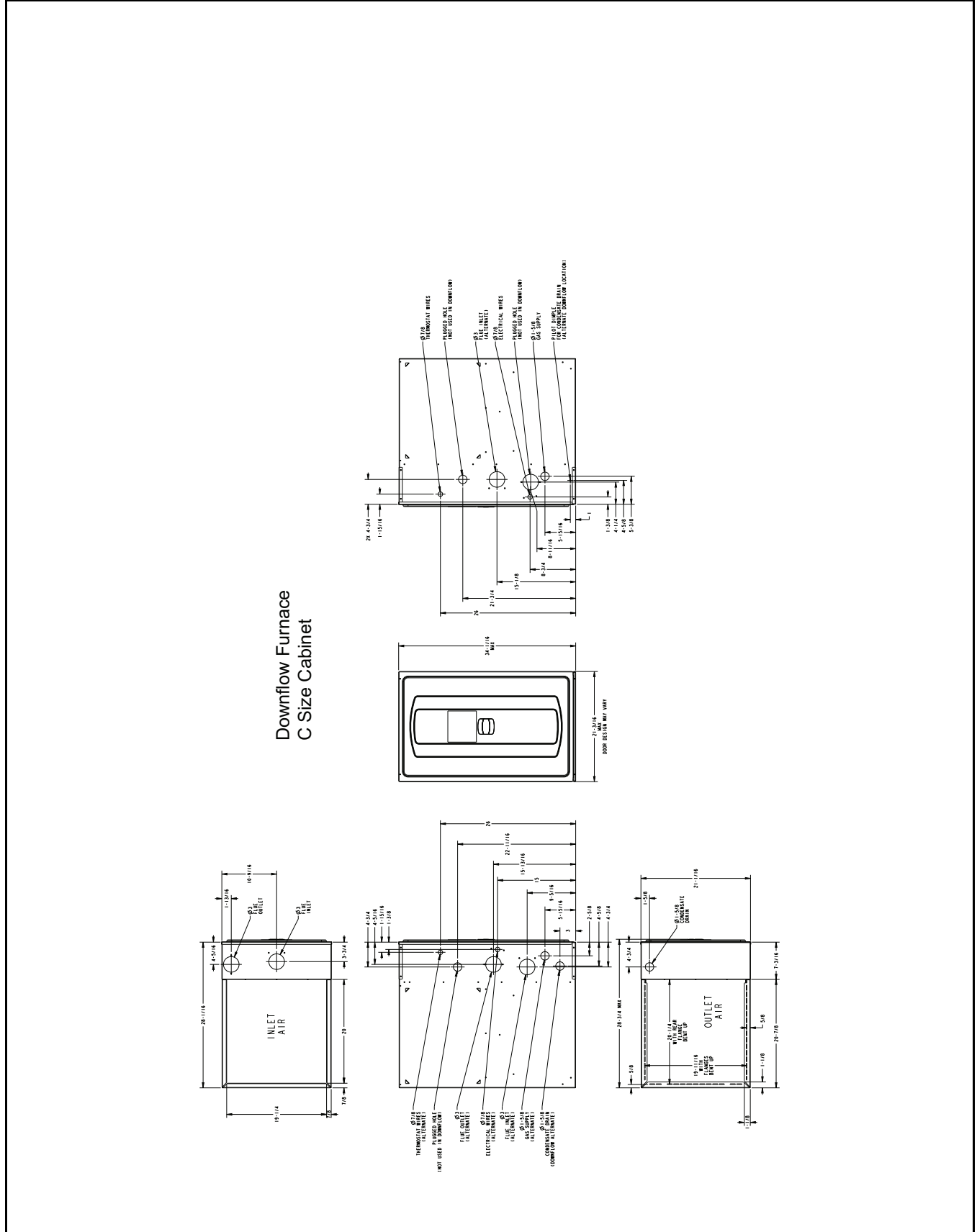

Table 8. 21" Downflow Cabinet





Trane - by Trane Technologies (NYSE: TT), a global innovator - creates comfortable, energy efficient indoor environments for commercial and residential applications. For more information, please visit trane.com or tranetechnologies.com.



Trane has a policy of continuous data improvement and it reserves the right to change design and specifications without notice. We are committed to using environmentally conscious print practices.