



# Product Data

## Wall Mount Air Handlers 2 – 3 Ton

### AC models

GMU2APB24051SA  
GMU2APB24081SA  
GMU2APB30051SA  
GMU2APB30081SA  
GMU2AEB37051SA  
GMU2AEB37101SA

### HP models

GMV2APB26051SA  
GMV2APB26081SA  
GMV2APB32051SA  
GMV2APB32081SA  
GMV2AEB39051SA  
GMV2AEB39101SA

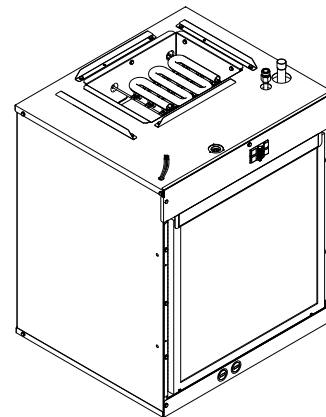

*The GMU and GMV series air handlers are designed for wall mount or flush mount installations in a closet, utility room, alcove, or basement. These versatile units are applicable to air conditioning and heat pump applications. Several models are available to meet the specific requirements of the outdoor equipment. Electric resistance heaters are factory installed.*



# Features

**Table 1. Standard Features**

<ul style="list-style-type: none"> <li>• GALVANIZED STEEL EXTERIOR</li> <li>• STURDY POLYCARBONATE DRAIN PAN</li> <li>• 208/230 VAC OPERATION</li> <li>• ECM MULTI-SPEED DIRECT DRIVE CTM BLOWER (GMU2AEB37101SA and GMV2AEB39101SA only)</li> <li>• MULTI-SPEED DIRECT DRIVE PSC BLOWER</li> <li>• FACTORY SUPPLIED R-410A THERMAL EXPANSION VALVE ON GMV MODELS</li> <li>• ALL ALUMINUM COIL</li> <li>• MEETS THE MINIMUM LEAKAGE REQUIREMENTS FOR THE FLORIDA AND CALIFORNIA BUILDING CODES</li> <li>• FRONT RETURN</li> <li>• Factory installed 5, 8, and 10 KW SINGLE PHASE ELECTRIC HEATERS             <ul style="list-style-type: none"> <li>– Circuit breakers on all heaters</li> </ul> </li> <li>• SUPPLY DUCT FLANGES</li> </ul>
--

**Table 2. Optional Accessories**

<p>Use with all GMU2 and GMV2 models</p> <ul style="list-style-type: none"> <li>• BAYTGM1WALLPNL — Wall Mount Panel Quantity 1</li> <li>• BAYTGM5WALLPNL — Wall Mount Panel Quantity 5</li> </ul> <p>Use with GMU2APB24 and GMV2APB26 models</p> <ul style="list-style-type: none"> <li>• BAYFRT5LVPNL26 — Louver Panel Quantity 5</li> <li>• BAYFRT1LVPNL26 — Louver Panel Quantity 1</li> </ul> <p>Use with GMU2APB30, GMU2AEB37, GMV2APB32, GMV2AEB39 models</p> <ul style="list-style-type: none"> <li>• BAYFRT5LVPNL30 — Louver Panel Quantity 5</li> <li>• BAYFRT1LVPNL30 — Louver Panel Quantity 1</li> </ul>
--

**Table 3. Optional Orifice Kits**

Outdoor Unit Capacity (Tons)	Orifice Size (R410A or R22)	Orifice Kit Number
1.5	0.049	BAYORIACHP0049
2.0	0.057	BAYORIACHP0057
2.5	0.061	BAYORIACHP0061
3.0	0.067	BAYORIACHP0067



# Product Specifications

MODEL	GMU2APB24051SA	GMU2APB24081SA	GMU2APB30051SA	GMU2APB30081SA
<b>RATED VOLTS/PH/HZ</b>	208-230/1/60	208-230/1/60	208-230/1/60	208-230/1/60
<b>RATINGS</b>	See O.D. Specifications	See O.D. Specifications	See O.D. Specifications	See O.D. Specifications
<b>INDOOR COIL — TYPE</b>	Plate Fin	Plate Fin	Plate Fin	Plate Fin
Refrigerant Control	Orifice	Orifice	Orifice	Orifice
Drain Conn. Size. (in.)	3/4" NPT	3/4" NPT	3/4" NPT	3/4" NPT
<b>FACTORY INSTALLED HEATER</b>	5 KW	8 KW	5 KW	8 KW
<b>DUCT CONNECTION</b>	10.75 x 16.00	10.75 x 16.00	10.75 x 16.00	10.75 x 16.00
<b>INDOOR MOTOR — TYPE</b>	PSC	PSC	PSC	PSC
Diameter-Width (in.)	10 — 6	10 — 6	10 — 6	10 — 6
No. Used	1	1	1	1
Drive — No. Speeds	Direct — 3	Direct — 3	Direct — 3	Direct — 3
CFM vs. in.W.G.	See Airflow Table	See Airflow Table	See Airflow Table	See Airflow Table
No. Motors — HP	1 — 1/8	1 — 1/8	1 — 1/3	1 — 1/3
Motor Speed RPM	825	825	825	825
Volts/Ph/Hz	208-230/1/60	208-230/1/60	208-230/1/60	208-230/1/60
F.L. Amps	0.9	0.9	2.2	2.2
<b>FILTER</b>				
Filter Furnished?	Yes	Yes	Yes	Yes
Filter Size (in.)	20 x 20 x 1	20 x 20 x 1	20 x 24 x 1	20 x 24 x 1
<b>REFRIGERANT</b>	R-410A	R-410A	R-410A	R-410A
Ref. Line Connections	Brazed	Brazed	Brazed	Brazed
Coupling or Conn Size — in. Gas	3/4	3/4	3/4	3/4
Coupling or Conn Size — in. Liq.	3/8 <sup>(a)</sup>	3/8 <sup>(a)</sup>	3/8 <sup>(a)</sup>	3/8 <sup>(a)</sup>
<b>DIMENSIONS (HxWxD)</b>				
Crated (in.)	29 x 22.5 x 20	29 x 22.5 x 20	33 x 22.5 x 20	33 x 22.5 x 20
Uncrated (in.)	25.43 x 22.11 x 19.34	25.43 x 22.11 x 19.34	29.43 x 22.11 x 19.34	29.43 x 22.11 x 19.34
<b>WEIGHT</b>				
Shipping / Net (lbs)	70 / 67	70 / 67	72 / 69	72 / 69

<sup>(a)</sup> Includes a mechanical fitting with a 3/8" braze connection



## Product Specifications

MODEL	GMU2AEB37051SA	GMU2AEB37101SA	GMV2APB26051SA	GMV2APB26081SA
<b>RATED VOLTS/PH/HZ</b>	208-230/1/60	208-230/1/60	208-230/1/60	208-230/1/60
<b>RATINGS</b>	See O.D. Specifications	See O.D. Specifications	See O.D. Specifications	See O.D. Specifications
<b>INDOOR COIL — TYPE</b>	Plate Fin	Plate Fin	Plate Fin	Plate Fin
Refrigerant Control	Orifice	Orifice	TXV	TXV
Drain Conn. Size. (in.)	3/4" NPT	3/4" NPT	3/4" NPT	3/4" NPT
<b>FACTORY INSTALLED HEATER</b>	5 KW	10 KW	5 KW	8 KW
<b>DUCT CONNECTION</b>	10.75 x 16.00	10.75 x 16.00	10.75 x 16.00	10.75 x 16.00
<b>INDOOR MOTOR — TYPE</b>	CTM	CTM	PSC	PSC
Diameter-Width (in.)	10 — 6	10 — 6	10 — 6	10 — 6
No. Used	1	1	1	1
Drive — No. Speeds	Direct — 3	Direct — 3	Direct — 5	Direct — 5
CFM vs. in.W.G.	See Airflow Table	See Airflow Table	See Airflow Table	See Airflow Table
No. Motors — HP	1 — 1/3	1 — 1/3	1 — 1/8	1 — 1/8
Motor Speed RPM	825	825	825	825
Volts/Ph/Hz	208-230/1/60	208-230/1/60	208-230/1/60	208-230/1/60
F.L. Amps	2.9	2.9	0.9	0.9
<b>FILTER</b>				
Filter Furnished?	Yes	Yes	Yes	Yes
Filter size (in.)	20 x 24 x 1	20 x 24 x 1	20 x 20 x 1	20 x 20 x 1
<b>REFRIGERANT</b>	R-410A	R-410A	R-410A	R-410A
Ref. Line Connections	Brazed	Brazed	Brazed	Brazed
Coupling or Conn Size — in. Gas	3/4	3/4	3/4	3/4
Coupling or Conn Size — in. Liq.	3/8 <sup>(a)</sup>	3/8 <sup>(a)</sup>	3/8 <sup>(a)</sup>	3/8 <sup>(a)</sup>
<b>DIMENSIONS</b>				
Crated (in.)	33 x 22.5 x 20	33 x 22.5 x 20	29 x 22.5 x 20	29 x 22.5 x 20
Uncrated (in.)	29.43 x 22.11 x 19.34	29.43 x 22.11 x 19.34	25.43 x 22.11 x 19.34	25.43 x 22.11 x 19.34
<b>WEIGHT</b>				
Shipping / Net (lbs)		73 / 70	73 / 70	73 / 70

<sup>(a)</sup> Includes a mechanical fitting with a 3/8" braze connection



## Product Specifications

MODEL	GMV2APB32051SA	GMV2APB32081SA	GMV2AEB39051SA	GMV2AEB39101SA
<b>RATED VOLTS/PH/HZ</b>	208-230/1/60	208-230/1/60	208-230/1/60	208-230/1/60
<b>RATINGS</b>	See O.D. Specifications	See O.D. Specifications	See O.D. Specifications	See O.D. Specifications
<b>INDOOR COIL — TYPE</b>	Plate Fin	Plate Fin	Plate Fin	Plate Fin
Refrigerant Control	TXV	TXV	TXV	TXV
Drain Conn. Size. (in.)	3/4" NPT	3/4" NPT	3/4" NPT	3/4" NPT
<b>FACTORY INSTALLED HEATER</b>	5 KW	8 KW	5 KW	10 KW
<b>DUCT CONNECTION</b>	10.75 x 16.00	10.75 x 16.00	10.75 x 16.00	10.75 x 16.00
<b>INDOOR MOTOR — TYPE</b>	PSC	PSC	CTM	CTM
Diameter-Width (in.)	10 — 6	10 — 6	10 — 6	10 — 6
No. Used	1	1	1	1
Drive — No. Speeds	Direct — 5	Direct — 5	Direct — 5	Direct — 5
CFM vs. in.W.G.	See Airflow Table	See Airflow Table	See Airflow Table	See Airflow Table
No. Motors — HP	1 — 1/3	1 — 1/3	1 — 1/3	1 — 1/3
Motor Speed RPM	825	825	825	825
Volts/Ph/Hz	208-230/1/60	208-230/1/60	208-230/1/60	208-230/1/60
F.L. Amps	2.2	2.2	2.9	2.9
<b>FILTER</b>				
Filter Furnished?	Yes	Yes	Yes	Yes
Filter size (in.)	20 x 24 x 1	20 x 24 x 1	20 x 24 x 1	20 x 24 x 1
<b>REFRIGERANT</b>	R-410A	R-410A	R-410A	R-410A
Ref. Line Connections	Brazed	Brazed	Brazed	Brazed
Coupling or Conn Size — in. Gas	3/4	3/4	3/4	3/4
Coupling or Conn Size — in. Liq.	3/8 <sup>(a)</sup>	3/8 <sup>(a)</sup>	3/8 <sup>(a)</sup>	3/8 <sup>(a)</sup>
<b>DIMENSIONS</b>				
Crated (in.)	33 x 22.5 x 20	33 x 22.5 x 20	33 x 22.5 x 20	33 x 22.5 x 20
Uncrated (in.)	29.43 x 22.11 x 19.34	29.43 x 22.11 x 19.34	29.43 x 22.11 x 19.34	29.43 x 22.11 x 19.34
<b>WEIGHT</b>				
Shipping / Net (lbs)	74 / 71	74 / 71	75 / 72	75 / 72

<sup>(a)</sup> Includes a mechanical fitting with a 3/8" braze connection



# Performance and Electrical Data

GMU2APB24051SA, GMU2APB24081SA						
External Static (in w.g.)	Airflow					
	Speed Taps - 230 Volts			Speed Taps - 208 Volts		
	High	Med †	Low	High	Med †	Low
0.1	1005.7	784.1	615.3	898.4	670.7	520.9
0.2	950.2	763.7	597.6	869.2	661.1	503.7
0.3	895.4	729.2	558.1	826.9	636.3	466.6
0.4	776.7	629.4	466.0	715.7	550.9	382.2
0.5	594.2	464.5	321.3	535.6	405.0	250.6
0.6	347.8	234.4		286.7	198.5	

Note:

1. Shaded boxes represent airflow outside the required 300-450 CFM/ton
2. Values are wet coil, no filter
3. CFM correction for dry coil = Add 3%
4. † = Factory default setting

Model No.	Heater Model No.	Number of Circuits / Phases	Motor Amps	Minimum Blower Speed		240 Volt				
				Without Heat Pump	With Heat Pump	Capacity		Heater Amps per Circuit	Minimum Circuit Ampacity	Maximum Overload Protection
						kW	BTUH			
GMU2APB24051SA	BAYHTRG605BRK	1/1	0.9	Low	N/A	4.8	16400	20	26	30
GMU2APB24081SA	BAYHTRG608BRK	1/1	0.9	Low	N/A	7.68	26200	32	41	45
Model No.	Heater Model No.	Number of Circuits / Phases	Motor Amps	Minimum Blower Speed		208 Volt				
				Without Heat Pump	With Heat Pump	Capacity		Heater Amps per Circuit	Minimum Circuit Ampacity	Maximum Overload Protection
						kW	BTUH			
GMU2APB24051SA	BAYHTRG605BRK	1/1	0.9	Low	N/A	3.6	12300	17.3	23	25
GMU2APB24081SA	BAYHTRG608BRK	1/1	0.9	Low	N/A	5.76	19700	27.7	36	40

## Performance and Electrical Data

GMV2APB26051SA, GMV2APB26081SA						
External Static (in w.g.)	Airflow					
	Speed Taps - 230 Volts			Speed Taps - 208 Volts		
	High	Med †	Low	High	Med †	Low
0.1	1020.5	784.5	613.9	903.2	669.3	520.7
0.2	973.3	769.6	598.4	878.7	662.9	506.9
0.3	936.4	741.5	564.3	858.9	643.6	474.4
0.4	832.3	647.8	478.4	770.6	563.4	393.5
0.5	661.1	488.4	340.9	614.0	422.3	264.3
0.6	422.8	263.3		389.0	220.3	

**Note:**

1. Shaded boxes represent airflow outside the required 300-450 CFM/ton
2. Values are wet coil, no filter
3. CFM correction for dry coil = Add 3%
4. † = Factory default setting

Model No.	Heater Model No.	Number of Circuits / Phases	Motor Amps	Minimum Blower Speed		<b>240 Volt</b>				
				Without Heat Pump	With Heat Pump	Capacity		Heater Amps per Circuit	Minimum Circuit Ampacity	Maximum Overload Protection
						kW	BTUH			
GMV2APB26051SA	BAYHTRG605BRK	1/1	0.9	Low	Low	4.8	16400	20	26	30
GMV2APB26081SA	BAYHTRG608BRK	1/1	0.9	Low	Low	7.68	26200	32	43	45
Model No.	Heater Model No.	Number of Circuits / Phases	Motor Amps	Minimum Blower Speed		<b>208 Volt</b>				
				Without Heat Pump	With Heat Pump	Capacity		Heater Amps per Circuit	Minimum Circuit Ampacity	Maximum Overload Protection
						kW	BTUH			
GMV2APB26051SA	BAYHTRG605BRK	1/1	0.9	Low	Low	3.6	12300	17.3	23	25
GMV2APB26081SA	BAYHTRG608BRK	1/1	0.9	Low	Low	5.76	19700	27.7	36	40



## Performance and Electrical Data

GMU2APB30081SA, GMU2APB30051SA						
External Static (in w.g.)	Airflow					
	Speed Taps - 230 Volts			Speed Taps - 208 Volts		
	High	Med †	Low	High	Med †	Low
0.1	1154.3	1086.0	1019.7	1139.6	1052.9	934.5
0.2	1091.6	1050.8	977.4	1073.2	1016.4	910.1
0.3	1037.4	996.2	932.2	1010.2	961.2	869.3
0.4	916.9	866.0	810.9	888.2	833.9	756.4
0.5	730.0	660.2	614.0	707.1	634.5	571.4
0.6	476.8	378.9		467.0	363.0	

**Note:**

1. Shaded boxes represent airflow outside the required 300-450 CFM/ton
2. Values are wet coil, no filter
3. CFM correction for dry coil = Add 3%
4. † = Factory default setting

Model No.	Heater Model No.	Number of Circuits / Phases	Motor Amps	Minimum Blower Speed		240 Volt				
				Without Heat Pump	With Heat Pump	Capacity		Heater Amps per Circuit	Minimum Circuit Ampacity	Maximum Overload Protection
						kW	BTUH			
GMU2APB30081SA	BAYHTRG608BRK	1/1	2.20	Low	N/A	7.68	26200	32	43	45
GMU2APB30051SA	BAYHTRG605BRK	1/1	2.20	Low	N/A	4.8	16400	20	28	30
Model No.	Heater Model No.	Number of Circuits / Phases	Motor Amps	Minimum Blower Speed		208 Volt				
				Without Heat Pump	With Heat Pump	Capacity		Heater Amps per Circuit	Minimum Circuit Ampacity	Maximum Overload Protection
						kW	BTUH			
GMU2APB30081SA	BAYHTRG608BRK	1/1	2.20	Low	N/A	5.76	19700	27.7	37	40
GMU2APB30051SA	BAYHTRG605BRK	1/1	2.20	Low	N/A	3.6	12300	17.3	24	25



## Performance and Electrical Data

GMV2APB32081SA, GMV2APB32051A						
External Static (in w.g.)	Airflow					
	Speed Taps - 230 Volts			Speed Taps - 208 Volts		
	High	Med †	Low	High	Med †	Low
0.1	1164.9	1104.4	1018.9	1130.7	1062.5	942.1
0.2	1095.5	1048.2	962.9	1063.6	994.1	903.2
0.3	1020.2	997.0	906.1	993.6	923.2	857.6
0.4	877.6	871.1	782.5	855.1	790.7	744.4
0.5	667.7	670.7	591.9	648.1	596.5	563.6
0.6	390.3	395.7		372.5	340.6	

**Note:**

1. Shaded boxes represent airflow outside the required 300-450 CFM/ton
2. Values are wet coil, no filter
3. CFM correction for dry coil = Add 3%
4. † = Factory default setting

Model No.	Heater Model No.	Number of Circuits / Phases	Motor Amps	Minimum Blower Speed		240 Volt				
				Without Heat Pump	With Heat Pump	Capacity		Heater Amps per Circuit	Minimum Circuit Ampacity	Maximum Overload Protection
						kW	BTUH			
GMV2APB32081SA	BAYHTRG608BRK	1/1	2.20	Low	Low	7.68	26200	32	43	45
GMV2APB32051SA	BAYHTRG605BRK	1/1	2.20	Low	Low	4.8	16400	20	28	30
Model No.	Heater Model No.	Number of Circuits / Phases	Motor Amps	Minimum Blower Speed		208 Volt				
				Without Heat Pump	With Heat Pump	Capacity		Heater Amps per Circuit	Minimum Circuit Ampacity	Maximum Overload Protection
						kW	BTUH			
GMV2APB32081SA	BAYHTRG608BRK	1/1	2.20	Low	Low	5.76	19700	27.7	37	40
GMV2APB32051SA	BAYHTRG605BRK	1/1	2.20	Low	Low	3.6	12300	17.3	24	25



## Performance and Electrical Data

GMU2AEB37101SA, GMU2AEB37051SA					
External Static (in w. g.)	Airflow				
	Speed Taps - 208-230 Volts				
	High	Med-High †	Med	Med-Low	Low
0.1	1129.5	1074.5	965.3	782.6	613.2
0.2	1107.0	1048.9	936.3	752.1	578.1
0.3	1084.0	1023.3	908.0	718.6	538.9
0.4	1060.3	997.8	880.5	692.2	495.7
0.5	1035.9	972.5	853.6	642.8	448.4
0.6	1011.0	947.1	827.4	600.4	697.1
0.7	985.5	921.9	802.0	555.1	341.7

**Note:**

1. Shaded boxes represent airflow outside the required 300-450 CFM/ton
2. Values are wet coil, no filter
3. CFM correction for dry coil = Add 3%
4. † = Factory default setting

Model No.	Heater Model No.	Number of Circuits / Phases	Motor Amps	Minimum Blower Speed		240 Volt				
				Without Heat Pump	With Heat Pump	Capacity		Heater Amps per Circuit	Minimum Circuit Ampacity	Maximum Overload Protection
						kW	BTUH			
GMU2AEB37101SA	BAYHTRG610BRK	1/1	2.90	Low	N/A	9.6	32800	40	54	60
GMU2AEB37051SA	BAYHTRG605BRK	1/1	2.90	Low	N/A	4.8	16400	20	29	30
Model No.	Heater Model No.	Number of Circuits / Phases	Motor Amps	Minimum Blower Speed		208 Volt				
				Without Heat Pump	With Heat Pump	Capacity		Heater Amps per Circuit	Minimum Circuit Ampacity	Maximum Overload Protection
						kW	BTUH			
GMU2AEB37101SA	BAYHTRG610BRK	1/1	2.90	Low	N/A	7.2	24600	34.6	47	50
GMU2AEB37051SA	BAYHTRG605BRK	1/1	2.90	Low	N/A	3.6	12300	17.3	25	25

## Performance and Electrical Data

GMV2AEB39101SA, GMV2AEB39051SA					
External Static (in w. g.)	Airflow				
	Speed Taps - 208-230 Volts				
	High	Med-High †	Med	Med-Low	Low
0.1	1110.7	1059.0	947.9	779.8	610.0
0.2	1085.2	1033.0	919.9	750.3	574.0
0.3	1059.7	1007.3	892.5	717.5	535.2
0.4	1034.1	981.8	865.6	681.6	493.7
0.5	1008.6	956.8	839.2	642.3	449.4
0.6	983.0	932.1	813.3	599.9	402.4
0.7	957.4	907.6	788.0	554.2	352.6

**Note:**

1. Shaded boxes represent airflow outside the required 300-450 CFM/ton
2. Values are wet coil, no filter
3. CFM correction for dry coil = Add 3%
4. † = Factory default setting

Model No.	Heater Model No.	Number of Circuits / Phases	Motor Amps	Minimum Blower Speed		240 Volt				
				Without Heat Pump	With Heat Pump	Capacity		Heater Amps per Circuit	Minimum Circuit Ampacity	Maximum Overload Protection
						kW	BTUH			
GMV2AEB39101SA	BAYHTRG610BRK	1/1	2.90	Low	M-L	9.6	32800	40	54	60
GMV2AEB39051SA	BAYHTRG605BRK	1/1	2.90	Low	Low	4.8	16400	20	29	30
Model No.	Heater Model No.	Number of Circuits / Phases	Motor Amps	Minimum Blower Speed		208 Volt				
				Without Heat Pump	With Heat Pump	Capacity		Heater Amps per Circuit	Minimum Circuit Ampacity	Maximum Overload Protection
						kW	BTUH			
GMV2AEB39101SA	BAYHTRG610BRK	1/1	2.90	Low	M-L	7.2	24600	34.6	47	50
GMV2AEB39051SA	BAYHTRG605BRK	1/1	2.90	Low	Low	3.6	12300	17.3	25	25

## Fixed Orifice Superheat Charging Table

Outdoor Dry Bulb Temperature (F)	Indoor Wet Bulb Temp (F)																												
	50	51	52	53	54	55	56	57	58	59	60	61	62	63	64	65	66	67	68	69	70	71	72	73	74	75	76	77	78
55	7	9	10	11	12	14	15	17	18	20	21	23	24	26	27	29	30												
60	5	7	8	9	10	12	13	15	16	18	19	21	22	24	25	27	28	30	31										
65			4	6	8	10	11	13	14	16	17	18	19	21	22	24	25	27	28	27	31								
70					5	7	8	10	11	13	14	16	17	18	19	21	22	24	25	27	28	30	31						
75						5	6	7	9	10	12	14	16	18	19	21	22	24	26	28	29	31	32						
80								4	6	7	9	10	11	12	14	16	18	19	21	23	25	26	28	29	31	33			
85									4	6	7	9	10	13	14	16	18	20	21	23	24	26	28	29	30	31	32		
90										4	6	8	10	11	13	14	16	18	20	22	24	25	27	28	30	31			
95											4	6	8	10	13	14	16	18	20	22	23	25	26	28	29				
100																6	8	10	12	13	16	18	20	21	23	25	27	29	
105																4	6	7	9	11	13	15	18	20	22	24	26	28	
110																	4	7	9	11	13	16	18	21	23	26	28		
115																			6	9	12	14	16	19	21	24	26		

Using a digital psychrometer, measure the return air wet-bulb temperature at the unit just before the coil. Also measure the outdoor dry-bulb temperature. Use these temperatures to locate the target superheat on the charging table. Do not attempt to charge the system if these conditions fall outside of this charging table.  
 ADD refrigerant to DECREASE total superheat. REMOVE refrigerant to INCREASE total superheat. Always allow 10 to 15 minutes of operation after any refrigerant or air flow change prior to determining the final superheat.

# Electrical Data

Figure 1. PSC Motor Wiring Diagram for GMU2APB24, GMU2APB30, GMV2APB26, and GMV2APB32

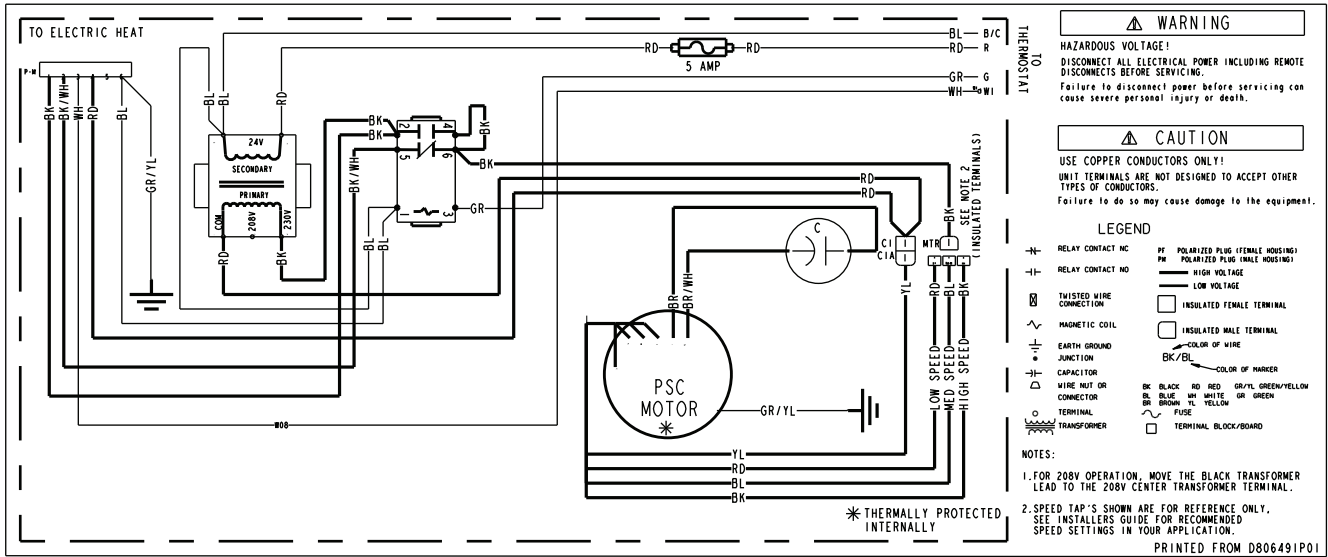

Figure 2. CTM Motor Wiring Diagram for GMU2AEB37 and GMV2AEB39

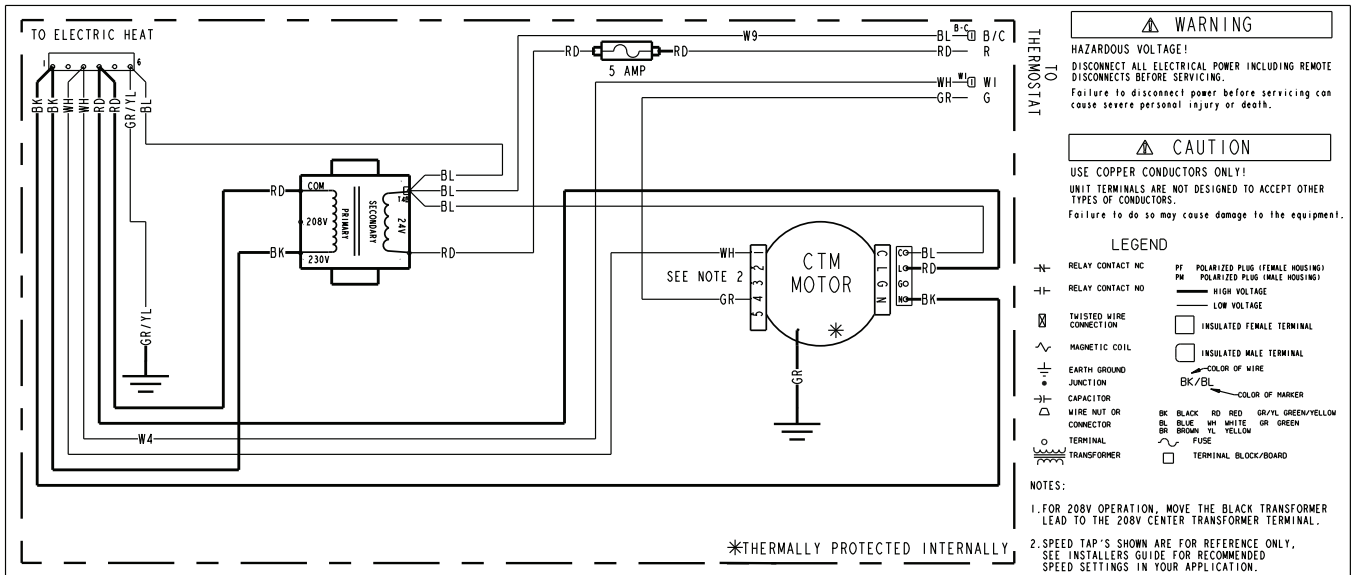
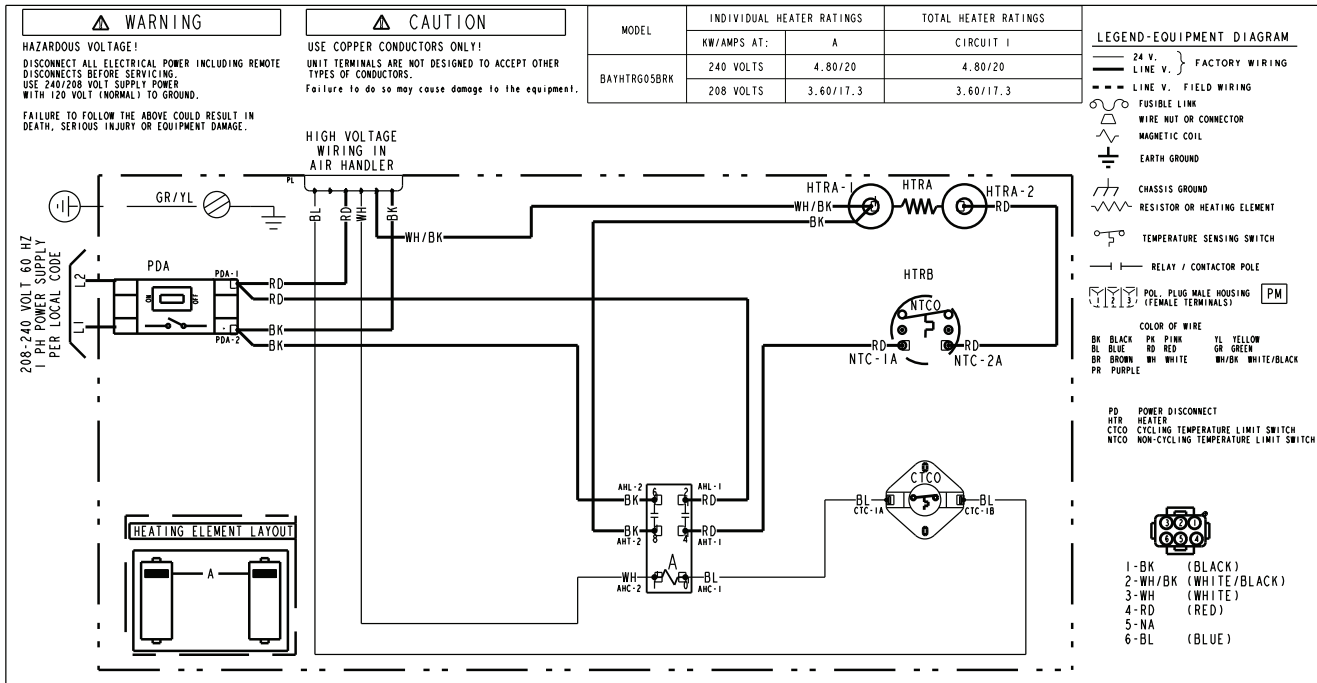
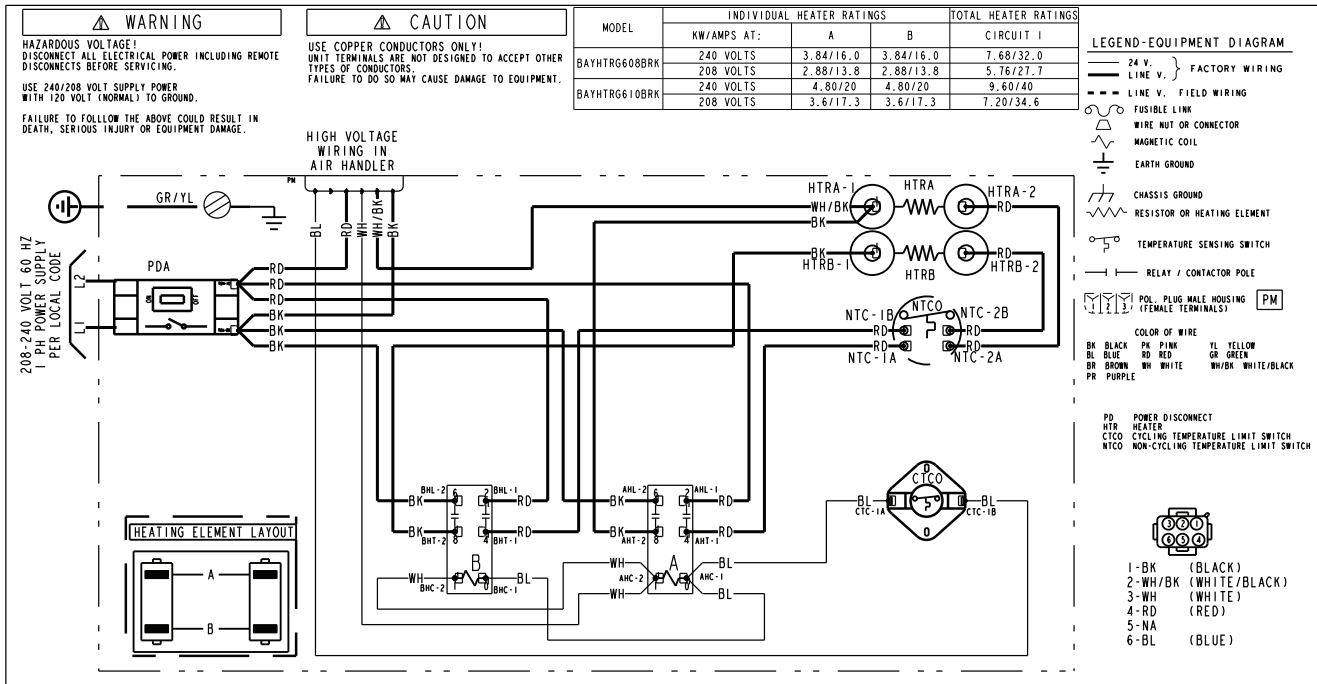

Figure 3. 5kW Heater Wiring for all \*051 models



PRINTED FROM D806718P01

Figure 4. 8kW and 10 kW Heater Wiring for all \*081 and \*\*101 models



PRINTED FROM D806649P01

# Field Wiring

## HEAT PUMP SYSTEMS

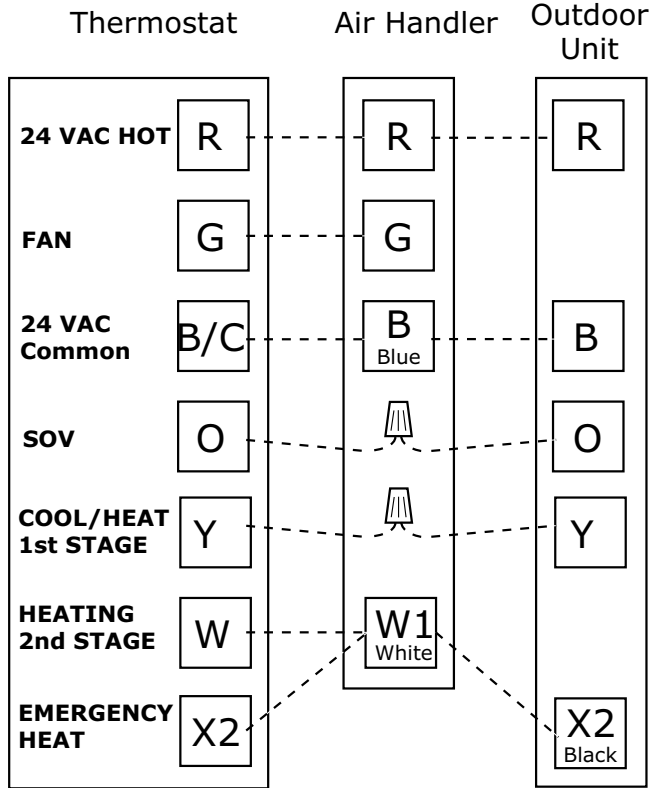

## AC SYSTEMS

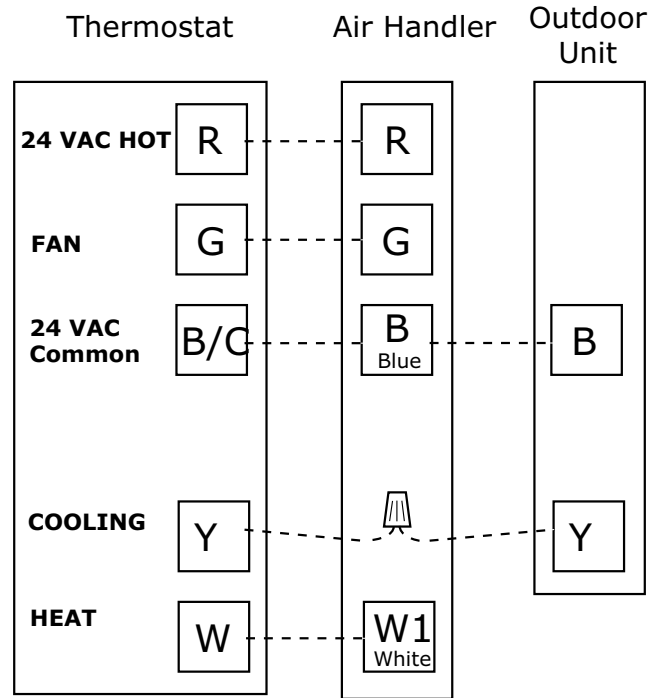

# Outline Drawing

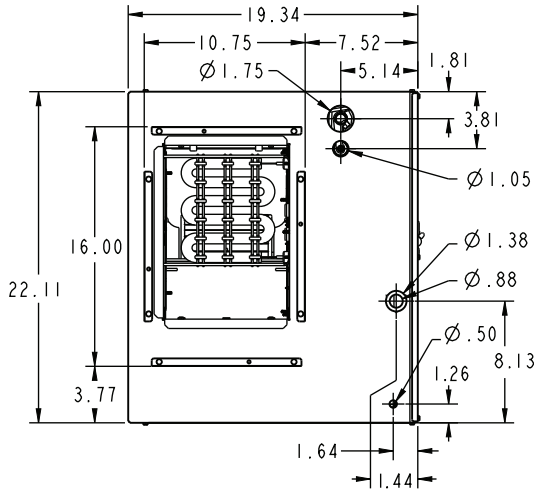

Minimum Unit Clearance Table		
	To Combustible Material (Required)	Service Clearance (Recommended)
Sides	0"	0"
Front	0"	21"
Back	0"	0"
Outlet Duct & Plenum	0"	N/A
Condensate Piping Below Cabinet	N/A	3"
TXV/Orifice Above Unit	N/A	9"

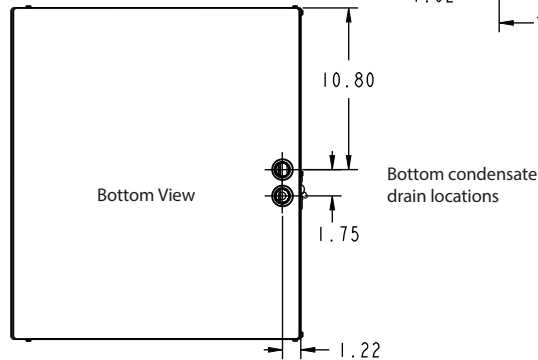
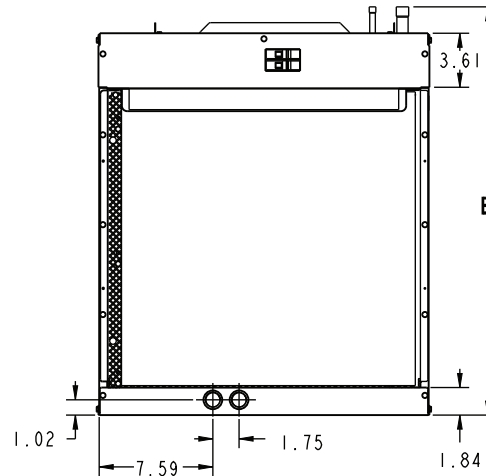
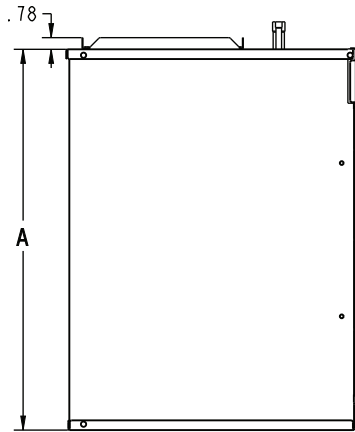

PRODUCT DIMENSIONS					
Air Handler Model	A	B	Gas Line Braze	Liquid Line Braze	Filter Size
GMU2APB24	25.43	27.26	3/4	3/8	20 x 20 x 1
GMU2APB30, GMU2AEB37	29.43	31.26	3/4	3/8	20 x 24 x 1
GMV2APB26	25.43	27.26	3/4	3/8 <sup>(a)</sup>	20 x 20 x 1
GMV2APB32, GMV2AEB39	29.43	31.26	3/4	3/8 <sup>(a)</sup>	20 x 24 x 1

All dimensions are in inches

<sup>(a)</sup> Includes a mechanical fitting with a 3/8" braze connection.



Trane - by Trane Technologies (NYSE: TT), a global innovator - creates comfortable, energy efficient indoor environments for commercial and residential applications. For more information, please visit [trane.com](http://trane.com) or [tranetechnologies.com](http://tranetechnologies.com).

---



Trane has a policy of continuous data improvement and it reserves the right to change design and specifications without notice. We are committed to using environmentally conscious print practices.