

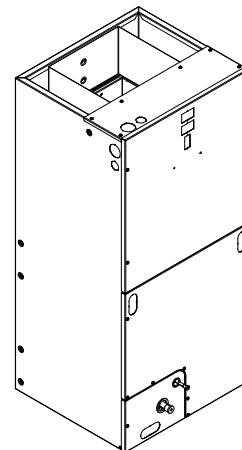

Product Data

Convertible Air Handlers 2 – 5 Ton

4TVM0024B100NB
4TVM0030B100NB
4TVM0036B100NB
4TVM0042B100NB
4TVM0048B100NB
4TVM0060B100NB



The 4TVM series air handler is designed for installation in a closet, utility room, alcove, basement, crawlspace or attic. These versatile units are applicable to VRF heat pump and simultaneous heating and cooling applications. Several models are available to meet the specific requirements of the outdoor equipment. Field installed electric resistance heaters are available.



Table of Contents

Features and Benefits	3
Optional Equipment	3
Product Specifications	4
Heater Pressure Drop Table 4TVM Air Handler Models.....	6
Minimum Airflow CFM	7
Performance and Electrical Data	8
Electrical Data	12
Field Wiring.....	14
Air Handling Unit Sensor Connections	17
4TVM Convertibility.....	18
4TVM Air Handler Dimensional Data.....	19
Outline Drawing	20



Features and Benefits

- Painted metal cabinet with captured foil face insulation
- 2% or less air leakage
- R-4.2 Insulating Value
- Multi-Position Upflow, Horizontal Left, and Horizontal Right
- ALL Aluminum Coil with Enhanced Patented Coil Fin
- Electric Heaters with polarized plug connections (sold as accessory)
- Factory installed Electronic Expansion Valve for VRF application
- Must be used with 4TVCTRLAHU0001A Convertible Air Handler Unit Control Box
- Draw Through Design
- Horizontal Drain pan
- Single Color
- Fused 24V Power

Optional Equipment

Accessory Number	Description	Fits Cabinet Size
BAYHTR1504BRK	Electric Heater, 4KW, Breaker, 24V Control, 1 Ph	18.5" and 23.5"
BAYHTR1504PDC	Electric Heater, 4KW, Pull Disconnect, 24V Control, 1 Ph	18.5" and 23.5"
BAYHTR1504LUG	Electric Heater, 4KW, Lug, 24V Control, 1 Ph	18.5" and 23.5"
BAYHTR1505BRK	Electric Heater, 5KW, Breaker, 24V Control, 1 Ph	18.5" and 23.5"
BAYHTR1505PDC	Electric Heater, 5KW, Pull Disconnect, 24V Control, 1 Ph	18.5" and 23.5"
BAYHTR1505LUG	Electric Heater, 5KW, Lug, 24V Control, 1 Ph	18.5" and 23.5"
BAYHTR1508BRK	Electric Heater, 4KW, Breaker, 24V Control, 1 Ph	18.5" and 23.5"
BAYHTR1508PDC	Electric Heater, 8KW, Pull Disconnect, 24V Control, 1 Ph	18.5" and 23.5"
BAYHTR1508LUG	Electric Heater, 8KW, Lug, 24V Control, 1 Ph	18.5" and 23.5"
BAYHTR1510BRK	Electric Heater, 10KW, Breaker, 24V Control, 1 Ph	18.5" and 23.5"
BAYHTR1510PDC	Electric Heater, 10KW, Pull Disconnect, 24V Control, 1 Ph	18.5" and 23.5"
BAYHTR3510LUG	Electric Heater, 10KW, Lug, 24V Control, 3 Ph	18.5" and 23.5"
BAYHTR3515LUG	Electric Heater, 10KW, Lug, 24V Control, 3 Ph	18.5" and 23.5"
BAYHTR1515BRK	Electric Heater, 15KW, Breaker, 24V Control, 1 Ph	18.5" and 23.5"
BAYHTR3515LUG	Electric Heater, 15KW, Lug, 24V Control, 3 Ph	18.5" and 23.5"
BAYHTR1519BRK	Electric Heater, 20KW, Breaker, 24V Control, 1 Ph	18.5" and 23.5"
BAYHTR1520BRK	Electric Heater, 20KW, Breaker, 24V Control, 1 Ph	18.5"
BAYTEMSPFG1A	Supply Duct Flange Kit	23.5"
BAYSPEKT201A	Single Point Power Entry Kit	18.5" and 23.5"
BAYTEMDFKT1A ^(a)	Downflow Condensate Management Kit	23.5" (5 Ton only)
TAYBASE185	Air Handler Downflow Sub-Bases	18.5"
TAYBASE235 (TAYBASE 100)	Air Handler Downflow Sub-Bases	23.5"

^(a) Required with all 5-ton air handler models in downflow orientation.



Product Specifications

MODEL	4TVM0024B100NB	4TVM0030B100NB	4TVM0036B100NB
RATED VOLTS/PH/HZ	208-230/1/60	208-230/1/60	208-230/1/60
RATINGS^(a)	See O.D. Specifications	See O.D. Specifications	See O.D. Specifications
INDOOR COIL — Type	Plate Fin	Plate Fin	Plate Fin
Rows — F.P.I.	3 - 14	3 - 14	3 - 14
Face Area (sq. ft.)	4.37	4.37	4.37
Tube Size (in.)	3/8	3/8	3/8
Refrigerant Control	TXV	TXV	TXV
Drain Conn. Size (in.) ^(b)	3/4 NPT	3/4 NPT	3/4 NPT
DUCT CONNECTIONS	See Outline Drawing	See Outline Drawing	See Outline Drawing
INDOOR FAN — Type	Centrifugal	Centrifugal	Centrifugal
Diameter-Width (In.)	9 X 7	10 X 8	10 X 8
No. Used	1	1	1
Drive - No. Speeds	Direct - 3	Direct - 3	Direct - 3
CFM vs. in. w.g.	See Fan Performance Table	See Fan Performance Table	See Fan Performance Table
No. Motors — H.P.	1 - 1/4	1 - 1/2	1 - 1/2
Motor Speed R.P.M.	1075	1075	1075
Volts/Ph/Hz	208-230/1/60	208-230/1/60	208-230/1/60
F.L. Amps	1.3	2.5	2.5
FILTER			
Filter Furnished? ^(c)	No	No	No
REFRIGERANT	R-410A	R-410A	R-410A
Ref. Line Connections	Brazed	Brazed	Brazed
Coupling or Conn. Size — in. Gas	5/8	3/4	7/8
Coupling or Conn. Size — in. Liq.	3/8	3/8	3/8
DIMENSIONS	H x W x D	H x W x D	H x W x D
Crated (In.)	46 x 21 x 24	46 x 21 x 24	46 x 21 x 24
Uncrated	45-1/8 x 18-1/2 x 21-1/8	45-1/8 x 18-1/2 x 21-1/8	45-1/8 x 18-1/2 x 21-1/8
WEIGHT			
Shipping (Lbs.) / Net (Lbs.)	126/120	140/132	150/142

^(a) These Air Handlers are A.H.R.I certified with various Split System Air Conditioners and Heat Pumps (AHRI STANDARD 210/240). Refer to the Split System Outdoor Unit Product Data Guides for performance data.

^(b) 3/4" Male Plastic Pipe (Ref: ASTM 1785-76)

^(c) Remote filter required.

Product Specifications

MODEL	4TVM0042B100NB	4TVM0048B100NB	4TVM0060B100NB
RATED VOLTS/PH/HZ	208-230/1/60	208-230/1/60	208-230/1/60
RATINGS^(a)	See O.D. Specifications	See O.D. Specifications	See O.D. Specifications
INDOOR COIL — Type	Plate Fin	Plate Fin	Plate Fin
Rows — F.P.I.	3 - 14	3 - 14	4 - 14
Face Area (sq. ft.)	5.50	5.50	5.91
Tube Size (in.)	3/8	3/8	3/8
Refrigerant Control	TXV	TXV	TXV
Drain Conn. Size (in.) ^(b)	3/4 NPT	3/4 NPT	3/4 NPT
DUCT CONNECTIONS	See Outline Drawing	See Outline Drawing	See Outline Drawing
INDOOR FAN — Type	Centrifugal	Centrifugal	Centrifugal
Diameter-Width (In.)	10 X 10	10 X 10	11 X 10
No. Used	1	1	1
Drive - No. Speeds	Direct - 3	Direct - 3	Direct - 3 ^(c)
CFM vs. in. w.g.	See Fan Performance Table	See Fan Performance Table	See Fan Performance Table
No. Motors — H.P.	1 - 1/2	1 - 1/2	1 - 3/4
Motor Speed R.P.M.	1075	1075	1050
Volts/Ph/Hz	208-230/1/60	208-230/1/60	208-230/1/60
F.L. Amps	2.6	2.6	6.3
FILTER			
Filter Furnished? ^(d)	No	No	No
REFRIGERANT	R-410A	R-410A	R-410A
Ref. Line Connections	Brazed	Brazed	Brazed
Coupling or Conn. Size — in. Gas	7/8	7/8	7/8
Coupling or Conn. Size — in. Liq.	3/8	3/8	3/8
DIMENSIONS	H x W x D	H x W x D	H x W x D
Crated (In.)	52-1/2 x 26 x 24	52-1/2 x 26 x 24	52-1/2 x 26 x 24
Uncrated	51-3/8 x 23-1/2 x 21-1/8	51-3/8 x 23-1/2 x 21-1/8	51-3/8 x 23-1/2 x 21-1/8
WEIGHT			
Shipping (Lbs.) / Net (Lbs.)	163/153	176/166	180/170

^(a) These Air Handlers are A.H.R.I certified with various Split System Air Conditioners and Heat Pumps (AHRI STANDARD 210/240). Refer to the Split System Outdoor Unit Product Data Guides for performance data.

^(b) 3/4" Male Plastic Pipe (Ref: ASTM 1785-76)

^(c) ECM motor

^(d) Remote filter required.



Heater Pressure Drop Table 4TVM Air Handler Models

Airflow CFM	Number of Racks				Heater Racks	
	1	2	3	4	Heater Model	No. of Racks
	Air Pressure Drop — Inches W.G.					
1800	0.02	0.04	0.06	0.14	BAYHTR1504	1
1700	0.02	0.04	0.06	0.14	BAYHTR1505	1
1600	0.02	0.04	0.06	0.13	BAYHTR1508	2
1500	0.02	0.04	0.06	0.12	BAYHTR1510	2
1400	0.02	0.04	0.06	0.12	BAYHTR3510	3
1300	0.02	0.04	0.05	0.11	BAYHTR1515	3
1200	0.01	0.04	0.05	0.10	BAYHTR3515	3
1100	0.01	0.03	0.05	0.09	BAYHTR1519	4
1000	0.01	0.03	0.04	0.09	BAYHTR1520	4
900	0.01	0.03	0.04	0.08	BAYHTR1521	4
800	0.01	0.03				
700	0.01	0.02				
600	0.01	0.02				



Minimum Airflow CFM

4TVM0024B1	
Heater	Minimum Heat Speed Tap
BAYHTR1504BRK, BAYHTR1504PDC, BAYHTR1504LUG, BAYHTR1505BRK, BAYHTR1505PDC, BAYHTR1505LUG	Med
BAYHTR1508BRK, BAYHTR1508PDC, BAYHTR1508LUG, BAYHTR1510BRK, BAYHTR1510PDC, BAYHTR1510LUG, BAYHTR3510LUG	Med

4TVM0030B1, 4TVM0036B1	
Heater	Minimum Heat Speed Tap
BAYHTR1504BRK, BAYHTR1504PDC, BAYHTR1504LUG, BAYHTR1505BRK, BAYHTR1505PDC, BAYHTR1505LUG	Med
BAYHTR1508BRK, BAYHTR1508PDC, BAYHTR1508LUG, BAYHTR1510BRK, BAYHTR1510PDC, BAYHTR1510LUG, BAYHTR3510LUG	Med
BAYHTR1515BRK, BAYHTR3515LUG, BAYHTR1519BRK	Med

4TVM0042B1, 4TVM0048B1	
Heater	Minimum Heat Speed Tap
BAYHTR1504BRK, BAYHTR1504PDC, BAYHTR1504LUG, BAYHTR1505BRK, BAYHTR1505PDC, BAYHTR1505LUG	Med
BAYHTR1508BRK, BAYHTR1508PDC, BAYHTR1508LUG, BAYHTR1510BRK, BAYHTR1510PDC, BAYHTR1510LUG, BAYHTR3510LUG	Med
BAYHTR1515BRK, BAYHTR3515LUG, BAYHTR1520BRK	Med

4TVM0060B1	
Heater	Minimum Heat Speed Tap
BAYHTR1504BRK, BAYHTR1504PDC, BAYHTR1504LUG, BAYHTR1505BRK, BAYHTR1505PDC, BAYHTR1505LUG	Med
BAYHTR1508BRK, BAYHTR1508PDC, BAYHTR1508LUG, BAYHTR1510BRK, BAYHTR1510PDC, BAYHTR1510LUG, BAYHTR3510LUG	Med
BAYHTR1515BRK, BAYHTR3515LUG, BAYHTR1520BRK	Med
Low = Taps 1-3	



Performance and Electrical Data

Table 1. Air Flow Performance

4TVM0024B1 (a)						
EXTERNAL STATIC (in w.g)	AIRFLOW					
	Speed Taps — 230 VOLTS			Speed Taps — 208 VOLTS		
	High	Med	Low †	High	Med	Low †
0.1	984	903	719	946	827	612
0.2	948	868	694	910	796	589
0.3	906	828	665	868	760	567
0.4	858	781	630	820	717	543
0.5	802	726	588	764	666	513
0.6	735	660	537	697	605	
0.7	651	581		614	532	

1. Values are with wet coil, no filter, and no heaters
 2. CFM Correction for dry coil = Add 3%
 3. † = Factory setting

(a) For the 4TVM0024B1, the recommended speed tap is medium at 0.4" external static pressure.

Table 2. Electrical Data

4TVM0024B1											
Heater Model No.	No. of Cir- cuits/ Phases	240 Volt					208 Volt				
		Capacity		Heater Amps per Circuit	Minimum Circuit Ampacity	Maximum Overload Protection	Capacity		Heater Amps per Circuit	Mini- mum Circuit Ampaci- ty	Maximum Overload Protection
		kW	BTUH				kW	BTUH			
No Heater				1.3 *	2	15			1.3 *	2	15
BAYHTR1504BRK BAYHTR1504PDC BAYHTR1504LUG	1/1	3.84	13100	16.0	22	25	2.88	9800	13.8	19	20
BAYHTR1505BRK BAYHTR1505PDC BAYHTR1505LUG	1/1	4.80	16400	20.0	27	30	3.60	12300	17.3	23	25
BAYHTR1508BRK BAYHTR1508PDC BAYHTR1508LUG	1/1	7.68	26200	32.0	42	45	5.76	19700	27.7	36	40
BAYHTR1510BRK BAYHTR1510PDC BAYHTR1510LUG	1/1	9.60	32800	40.0	52	60	7.20	24600	34.6	45	45
BAYHTR3510LUG	1/3	9.60	32800	23.1	30	30	7.20	24600	20.0	26	30

* = Motor Amps
 Wiring schematics provided from VRF Select will need to be reviewed for proper wiring and disconnect selection if electric heat is added to the air handler

Table 3. Air Flow Performance

4TVM0030B1, 4TVM0036B1 (a)						
EXTERNAL STATIC (in w.g)	AIRFLOW					
	Speed Taps — 230 VOLTS			Speed Taps — 208 VOLTS		
	High	Med	Low †	High	Med	Low †
0.1	1461	1336	979	1406	1173	834
0.2	1404	1291	971	1352	1152	819
0.3	1344	1242	962	1295	1121	810
0.4	1281	1188	944	1234	1081	804
0.5	1214	1130	916	1169	1035	791
0.6	1142	1066	876	1100	981	768
0.7	1066	997		1026	920	732

1. Values are with wet coil, no filter, and no heaters
2. CFM Correction for dry coil = Add 3%
3. † = Factory setting

(a) For 4TVM0036B1, the recommended speed tap is medium at 0.4" external static pressure.

Table 4. Electrical Data

4TVM0030B1, 4TVM0036B1											
Heater Model No.	No. of Circuits/ Phases	240 Volt					208 Volt				
		Capacity		Heater Amps per Circuit	Minimum Circuit Ampacity	Maximum Overload Protection	Capacity		Heater Amps per Circuit	Minimum Circuit Ampacity	Maximum Overload Protection
		kW	BTUH				kW	BTUH			
No Heater				2.5 *	3	15			2.5 *	3	15
BAYHTR1504BRK BAYHTR1504PDC BAYHTR1504LUG	1/1	3.84	13100	16.0	23	25	2.88	9800	13.8	20	20
BAYHTR1505BRK BAYHTR1505PDC BAYHTR1505LUG	1/1	4.8	16400	20.0	28	30	3.6	12300	17.3	25	25
BAYHTR1508BRK BAYHTR1508PDC BAYHTR1508LUG	1/1	7.68	26200	32.0	43	45	5.76	19700	27.7	38	40
BAYHTR1510BRK BAYHTR1510PDC BAYHTR1510LUG	1/1	9.6	32800	40.0	53	60	7.2	24600	34.6	46	50
BAYHTR1515BRK- Circuit 1 (a)	2/1	9.6	32800	40.0	53	60	7.2	24600	34.6	46	50
BAYHTR1515BRK- Circuit 2		4.8	16400	20.0	25	25	3.6	12300	17.3	22	25
BAYHTR1519BRK- Circuit 1 (a)	2/1	9.6	32800	40.0	53	60	7.2	24600	34.6	46	50
BAYHTR1519BRK- Circuit 2		9.6	32800	40.0	50	50	7.2	24600	34.6	43	45
BAYHTR3510LUG	1/3	9.6	32800	23.1	32	35	7.2	24600	20.0	28	30
BAYHTR3515LUG	1/3	14.4	49200	34.6	46	50	10.8	36900	30.0	40	40
BAYHTR1515BRK with single circuit power source kit BAYSPEKT201A	1/1	14.4	49200	60.0	83	90	10.8	36900	51.9	73	80
BAYHTR1519BRK with single circuit power source kit BAYSPEKT201A	1/1	19.2	65500	80.0	108	110	14.4	49200	69.2	94	100

* = Motor Amps
Wiring schematics provided from VRF Select will need to be reviewed for proper wiring and disconnect selection if electric heat is added to the air handler

(a) MCA and MOP for circuit 1 contains the motor amps



Performance and Electrical Data

Table 5. Air Flow Performance

4TVM0042B1, 4TVM0048B1 (a)						
EXTERNAL STATIC (in w.g)	AIRFLOW					
	Speed Taps — 230 VOLTS			Speed Taps — 208 VOLTS		
	High	Med	Low †	High	Med	Low †
0.1	1959	1704	1344	1786	1465	1154
0.2	1898	1675	1332	1748	1462	1126
0.3	1828	1631	1325	1697	1444	1108
0.4	1750	1574	1310	1633	1410	1095
0.5	1662	1504	1277	1557	1359	1076
0.6	1563	1420	1223	1468	1289	1039
0.7	1452	1321		1365		

1. Values are with wet coil, no filter, and no heaters
 2. CFM Correction for dry coil = Add 3%
 3. † = Factory setting

(a) For 4TVM0048B1, the recommended speed tap is medium at 0.4" external static pressure.

Table 6. Electrical Data

4TVM0042B1, 4TVM0048B1											
Heater Model No.	No. of Circuits/ Phases	240 Volt					208 Volt				
		Capacity		Heater Amps per Circuit	Minimum Circuit Ampacity	Maximum Overload Protection	Capacity		Heater Amps per Circuit	Minimum Circuit Ampacity	Maximum Overload Protection
		kW	BTUH				kW	BTUH			
No Heater				2.6 *	3	15			2.6 *	3	15
BAYHTR1504BRK BAYHTR1504PDC BAYHTR1504LUG	1/1	3.84	13100	16.0	23	25	2.88	9800	13.8	21	25
BAYHTR1505BRK BAYHTR1505PDC BAYHTR1505LUG	1/1	4.8	16400	20.0	28	30	3.6	12300	17.3	25	25
BAYHTR1508BRK BAYHTR1508PDC BAYHTR1508LUG	1/1	7.68	26200	32.0	43	45	5.76	19700	27.7	38	40
BAYHTR1510BRK BAYHTR1510PDC BAYHTR1510LUG	1/1	9.6	32800	40.0	53	60	7.2	24600	34.6	47	50
BAYHTR1515BRK- Circuit 1 (a)	2/1	9.6	32800	40.0	53	60	7.2	24600	34.6	47	50
BAYHTR1515BRK- Circuit 2		4.8	16400	20.0	25	25	3.6	12300	17.3	22	25
BAYHTR1520BRK- Circuit 1 (a)	2/1	9.6	32800	40.0	53	60	7.2	24600	34.6	47	50
BAYHTR1520BRK- Circuit 2		9.6	32800	40.0	50	50	7.2	24600	34.6	43	45
BAYHTR3510LUG	1/3	9.6	32800	23.1	32	35	7.2	24600	20.0	28	30
BAYHTR3515LUG	1/3	14.4	49200	34.6	46	50	10.8	36900	30.0	40	40
BAYHTR1515BRK with single circuit power source kit BAYSPEKT201A	1/1	14.4	49200	60.0	83	90	10.8	36900	51.9	73	80
BAYHTR1520BRK with single circuit power source kit BAYSPEKT201A	1/1	19.2	65500	80.0	108	110	14.4	49200	69.2	94	100

* = Motor Amps
 Wiring schematics provided from VRF Select will need to be reviewed for proper wiring and disconnect selection if electric heat is added to the air handler

(a) MCA and MOP for circuit 1 contains the motor amps.

Table 7. Air Flow Performance

4TVM0060B1			
EXTERNAL STATIC (in w.g)	AIRFLOW		
	Speed Taps — 208 – 230 VOLTS		
	High	Med †	Low
0.1	1954	1864	1780
0.2	1919	1827	1741
0.3	1885	1791	1704
0.4	1852	1756	1668
0.5	1821	1723	1633
0.6	1790	1691	1599
0.7	1761	1660	1567

1. Values are with wet coil, no filter, and no heaters
2. CFM Correction for dry coil = Add 3%
3. † = Factory Setting
4. Low = Taps 1–3, Med = Tap 4, High = Tap 5

Table 8. Electrical Data

4TVM0060B1											
Heater Model No.	No. of Circuits/ Phases	240 Volt					208 Volt				
		Capacity		Heater Amps per Circuit	Minimum Circuit Ampacity	Maximum Overload Protection	Capacity		Heater Amps per Circuit	Minimum Circuit Ampacity	Maximum Overload Protection
		kW	BTUH				kW	BTUH			
No Heater				6.3 *	8	15			6.3 *	8	15
BAYHTR1504BRK BAYHTR1504PDC BAYHTR1504LUG	1/1	3.84	13100	16.0	28	30	2.88	9800	13.8	25	25
BAYHTR1505BRK BAYHTR1505PDC BAYHTR1505LUG	1/1	4.8	16400	20.0	33	35	3.6	12300	17.3	30	30
BAYHTR1508BRK BAYHTR1508PDC BAYHTR1508LUG	1/1	7.68	26200	32.0	48	50	5.76	19700	27.7	42	45
BAYHTR1510BRK BAYHTR1510PDC BAYHTR1510LUG	1/1	9.6	32800	40.0	58	60	7.2	24600	34.6	51	60
BAYHTR1515BRK- Circuit 1 ^(a)	2/1	9.6	32800	40.0	58	60	7.2	24600	34.6	51	60
BAYHTR1515BRK- Circuit 2		4.8	16400	20.0	25	25	3.6	12300	17.3	22	25
BAYHTR1520BRK- Circuit 1 ^(a)	2/1	9.6	32800	40.0	58	60	7.2	24600	34.6	51	60
BAYHTR1520BRK- Circuit 2		9.6	32800	40.0	50	50	7.2	24600	34.6	43	45
BAYHTR3510LUG	1/3	9.6	32800	23.1	36	40	7.2	24600	20.0	32	35
BAYHTR3515LUG	1/3	14.4	49200	34.6	50	50	10.8	36900	30.0	44	45
BAYHTR1515BRK with single circuit power source kit BAYSPEKT201A	1/1	14.4	49200	60.0	83	90	10.8	36900	51.9	73	80
BAYHTR1520BRK with single circuit power source kit BAYSPEKT201A	1/1	19.2	65500	80.0	108	110	14.4	49200	69.2	94	100

* = Motor Amps
Wiring schematics provided from VRF Select will need to be reviewed for proper wiring and disconnect selection if electric heat is added to the air handler

^(a) MCA and MOP for circuit 1 contains the motor amps.

Electrical Data

Figure 1. 4TVM0024B1-0048B1

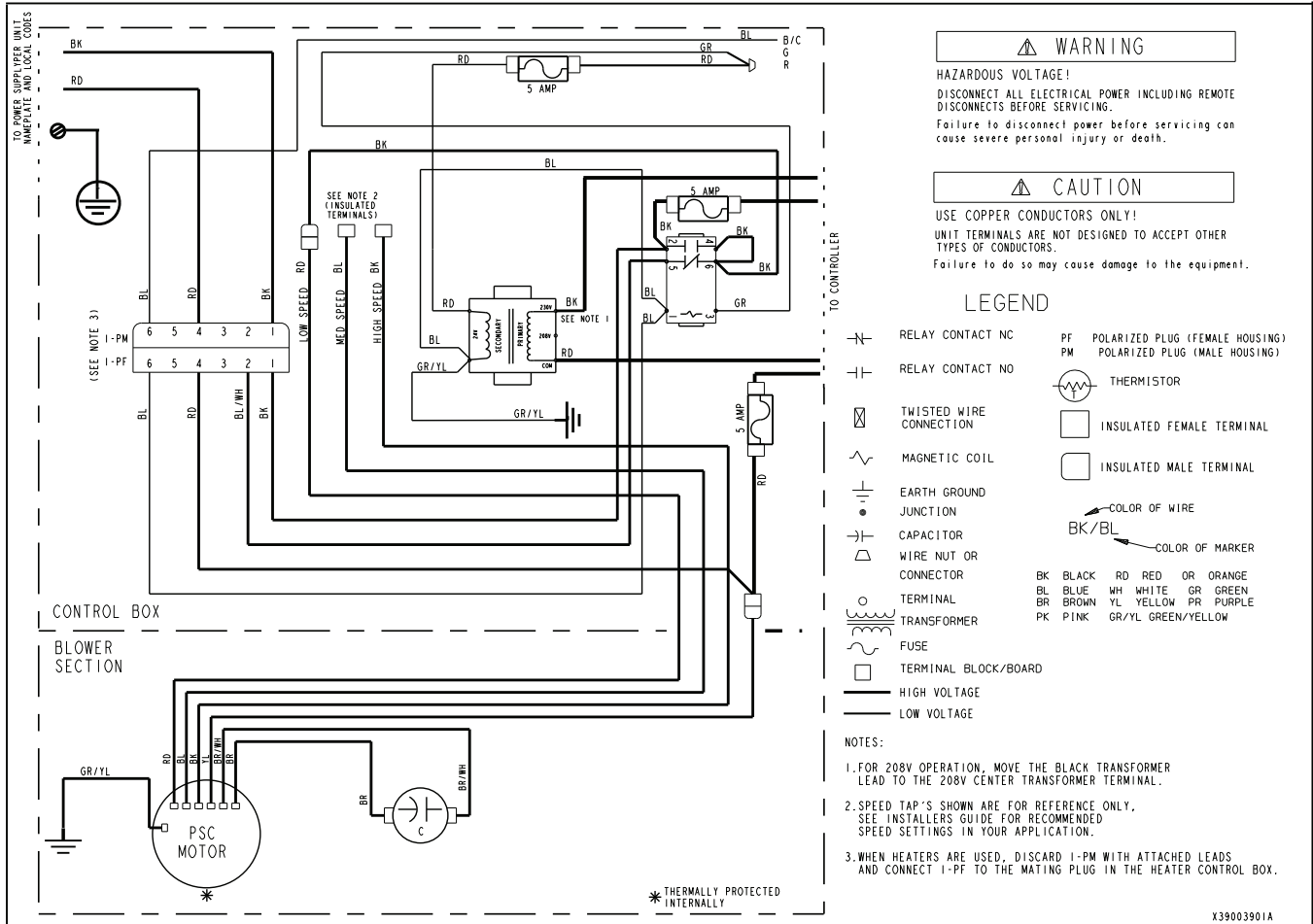
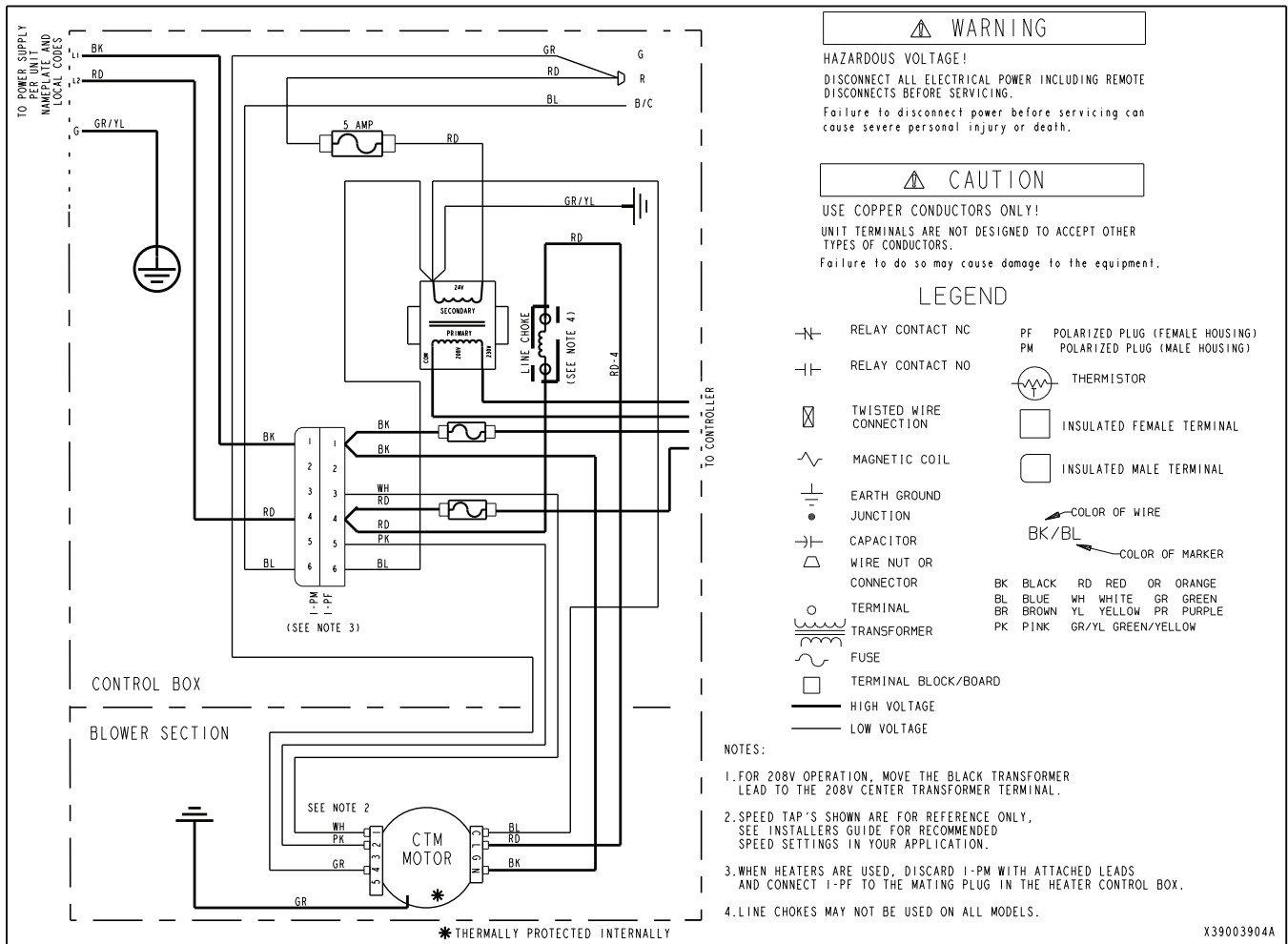

Figure 2. 4TVM0060B1



Field Wiring

Refer to VRF-SVN075A-EN, which ships with the separate control box required for use with the 4TVM air handling unit.

Figure 3. Field Wiring Overview

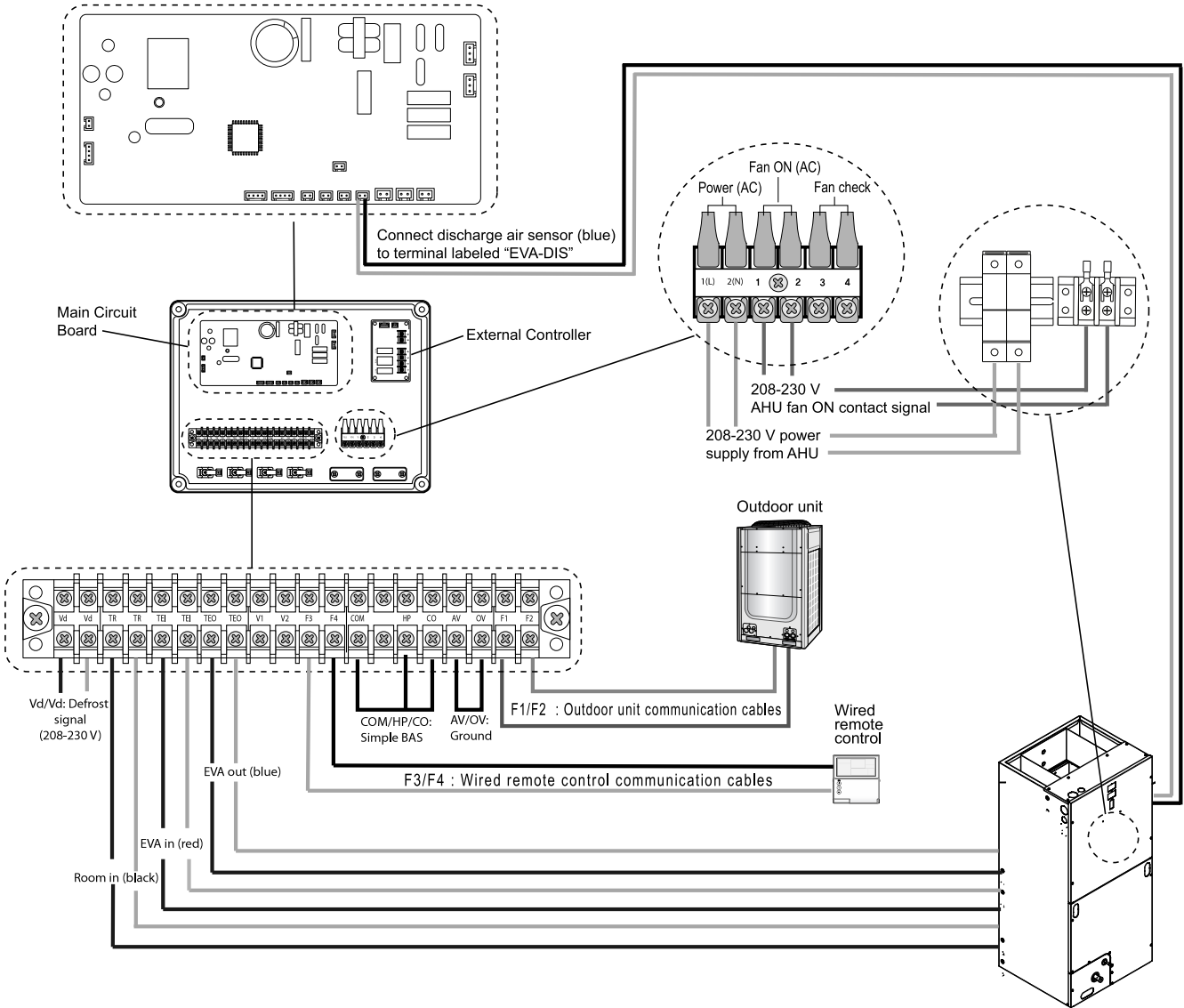

Figure 4. 4TVM unit with AHU kit and no electric heat

Air handling unit (4TVM) with AHU Kit and no electric heat.

The AHU kit cycles the high voltage to the air handling unit transformer. High voltage is picked up from the factory installed connector block located in the electric heat compartment as shown.

The high voltage from the 4TVM to the AHU kit is fused and connects to 1(L) and 2(N) on the terminal strip located inside the AHU kit. (Power (AC))

Fan ON (AC) terminals 1 and 2 are from the AHU Kit are routed back to the air handling unit high voltage terminal strip with the red and black wires.

Use the high voltage pigtailed from the 4TVM air handling unit's polarized connector to supply high voltage power to the air handling unit. Use the electrical tables located on the unit nameplate for the branch circuit electrical power requirements. Tables are printed in this document for convenience.

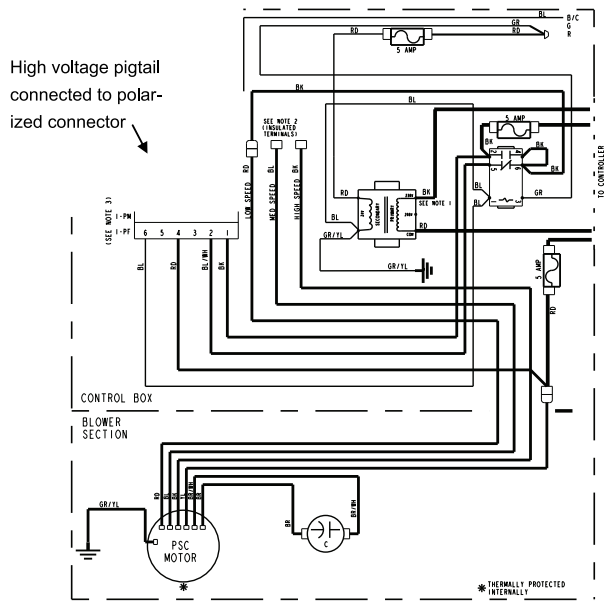
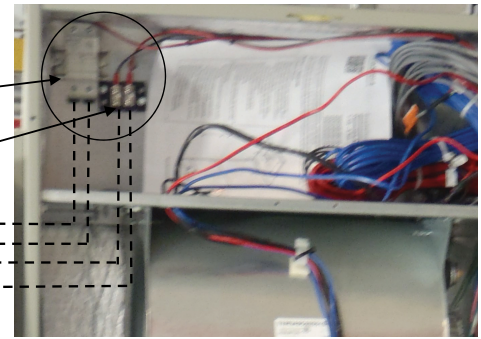

Wiring schematic from 4TVM0024 - 0048B1

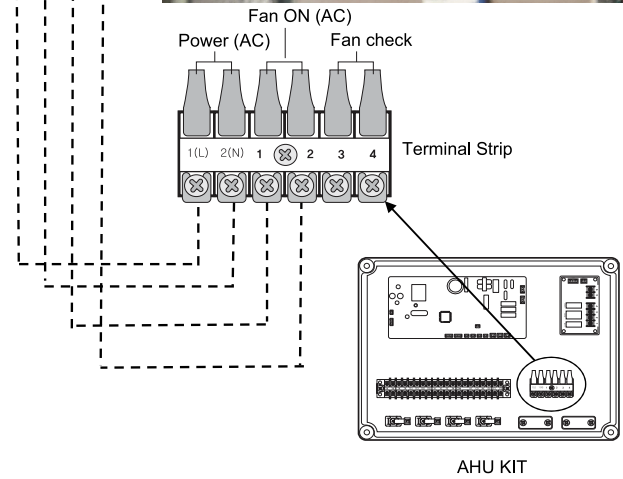

Figure 5. 4TVM with electric heat

4TVM with electric heat:

1. Install the BAYHTR15** series heater per the accompanying installation guide shipped with the heater.
2. Remove the pigtail section from the air handling unit's polarized plug and connect the polarized connector from the heater to the air handling unit.
3. Connect high voltage to electric heater breakers, pigtails or lugs based on electrical data from the unit nameplate. Some heaters will require two sources of high voltage or a single point power entry kit (BAYSPEKT***)

Low voltage wiring:

1. Connect the white wire from the electric heater (w1) to terminal 3 located on the external contact interface. (if heater is multi-staged, connect the Pink wire (W2) to terminal 3 as well)
2. Connect the fused 24 volt (red wire) from the air handling unit to terminal 4 located on the external contact interface.
3. If the heater is multi-stage, then both stages will energize at the same time.

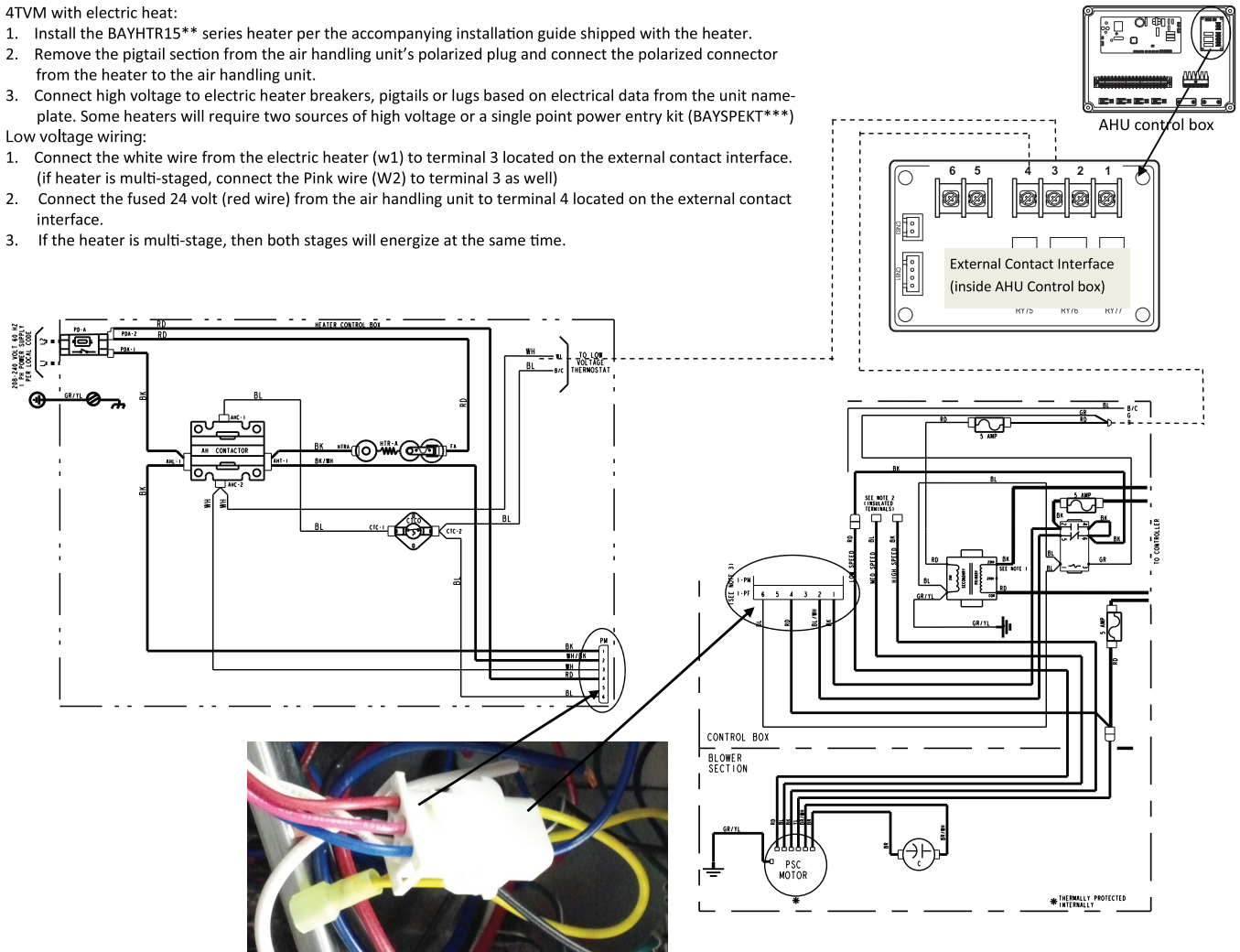

Air Handling Unit Sensor Connections

The 4TVM ships with all sensors connected internally, however, they must be terminated on the AHU Kit.

Sensor list:

- Discharge Air Sensor – Blue (“DISCHARGE” checked on label)
- Return Air Sensor – Black (Room In)
- Evap In Sensor – Red (EVA IN)
- Evap Out Sensor – Blue (“EVA OUT” checked on label)

Important: Do not remove the plug from the blue Discharge Air Sensor with “DISCHARGE” checked on the label.



Important: If the red and black sensor wires are shipped connected by plug, the plug must be removed and wires stripped.

Important: If the blue Evap Out Sensor ships with a connection plug, the plug must be removed and wires stripped.

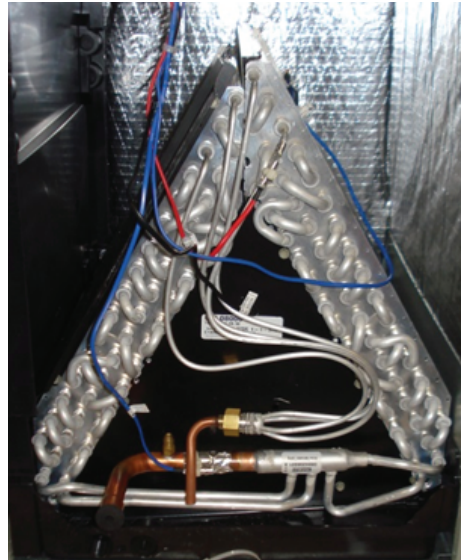

Location of sensors on coil

The Black Sensor labeled “Room In” connects to terminals “TR”.

The Red Sensor labeled “EVA IN” connects to terminals “TB”.

The Blue Sensor with “EVA OUT” checked on the label connects to terminals **TEO**.

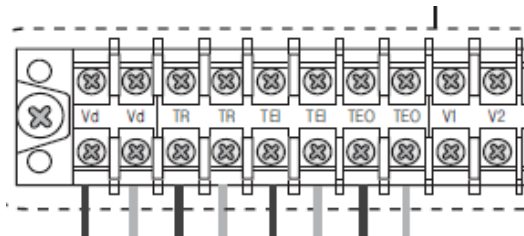

The second Blue Sensor with “DISCHARGE” checked on the label connects to the main board on the terminal labeled “EVA-DIS”. This sensor has a plug on the end of it to connect to the board.

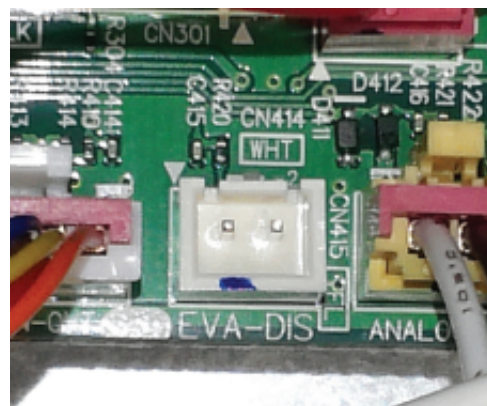

4TVM Convertibility

Figure 6. Multi-Position Air Handler
 * = No Internal Modifications Required.

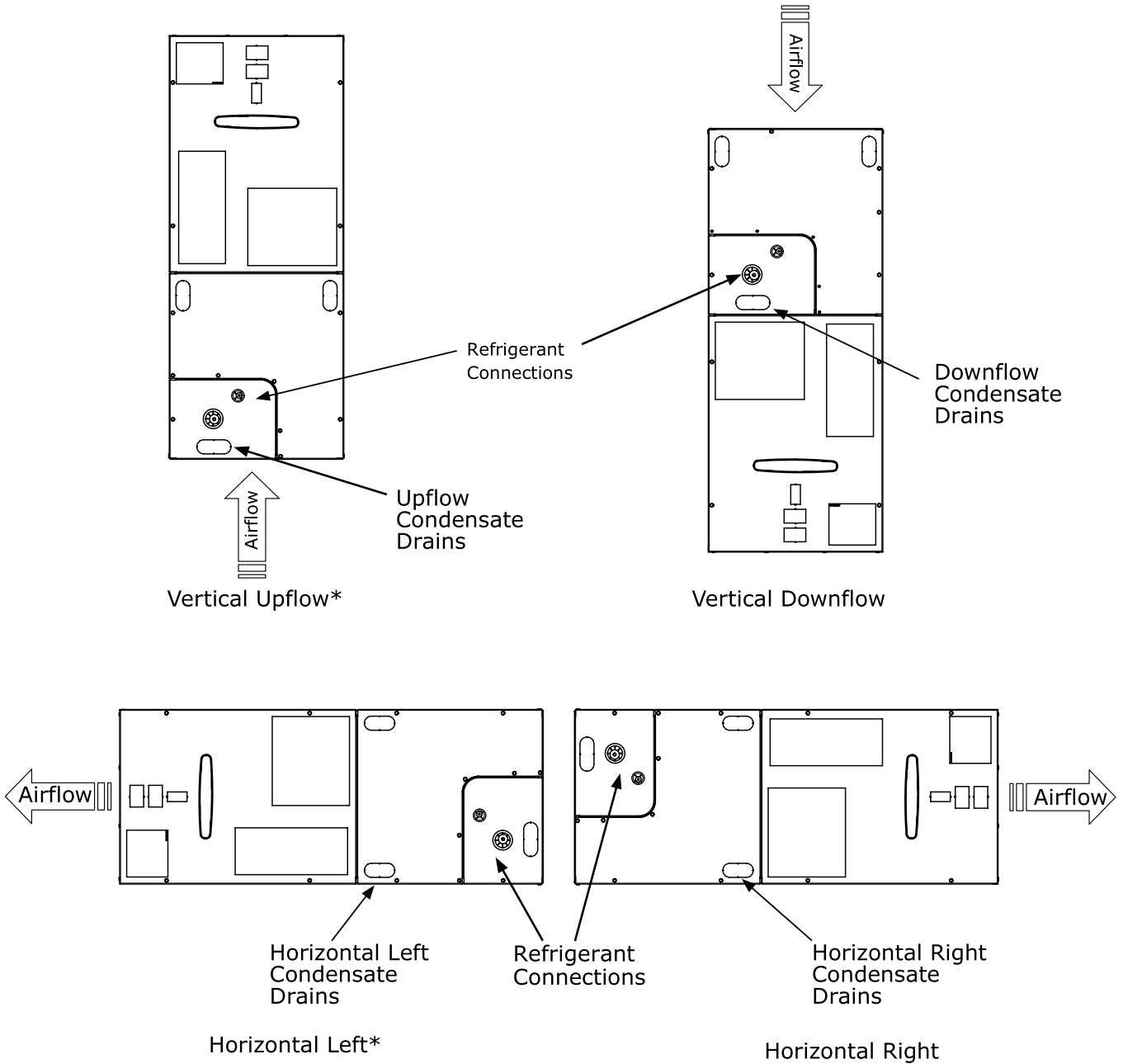



4TVM Air Handler Dimensional Data

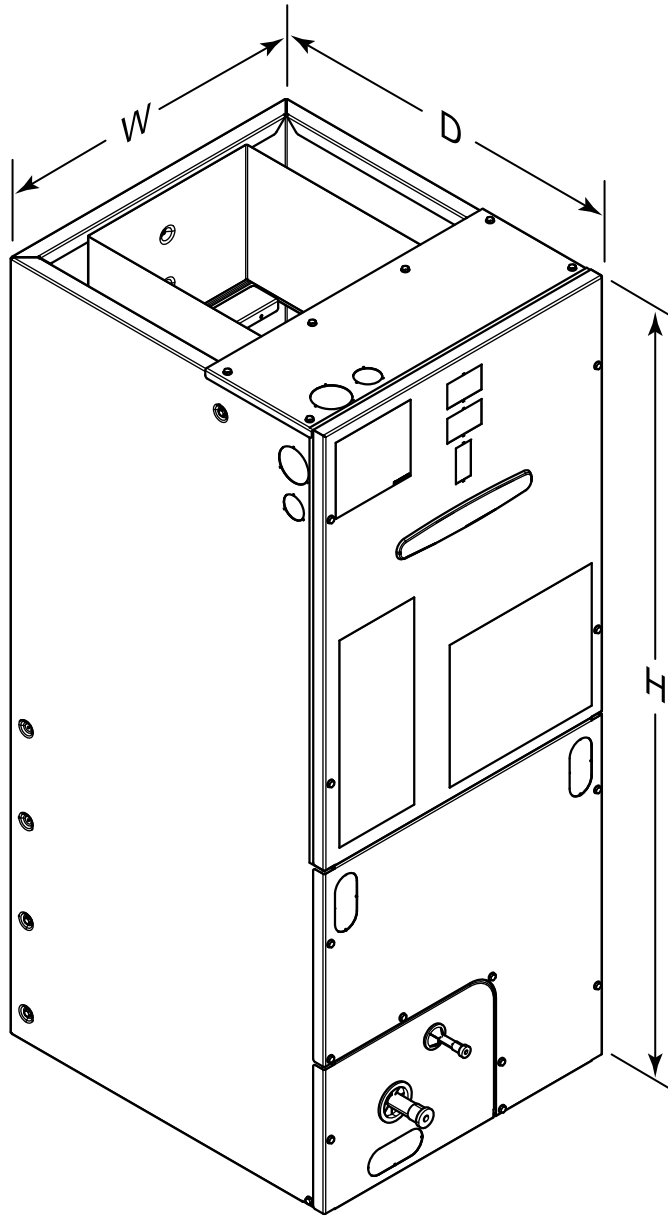

Model No.	H	W	D
4TVM0024B100NB	45.13	18.50	21.13
4TVM0030B100NB	45.13	18.50	21.13
4TVM0036B100NB	45.13	18.50	21.13
4TVM0042B100NB	51.37	23.50	21.13
4TVM0048B100NB	51.37	23.50	21.13
4TVM0060B100NB	51.37	23.50	21.13

Outline Drawing

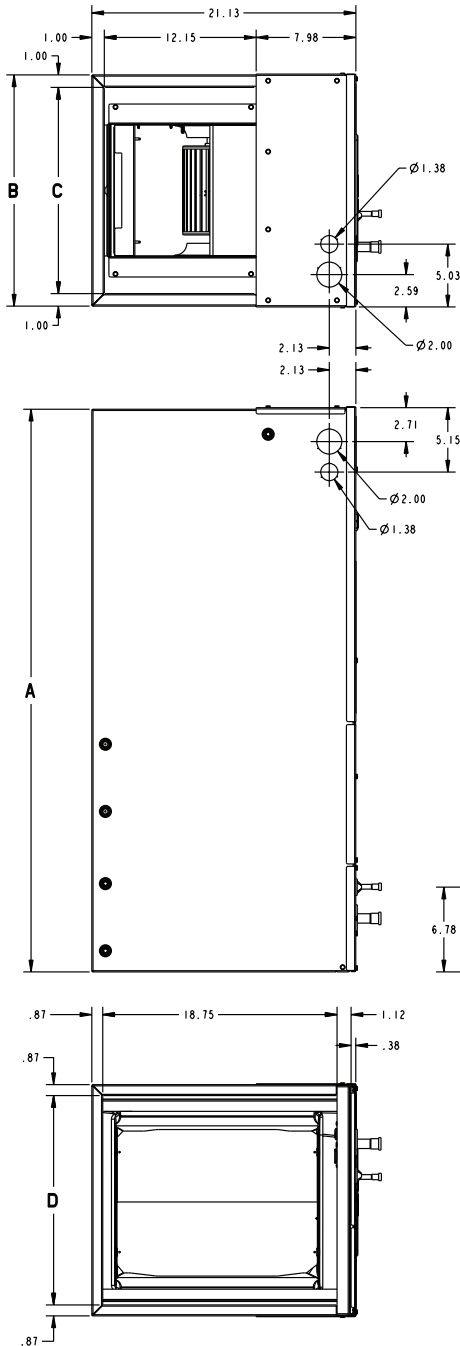

MINIMUM UNIT CLEARANCE TABLE		
	TO COMBUSTIBLE MATERIAL (REQUIRED)	SERVICE CLEARANCE (RECOMMENDED)
SIDES	0"	2"
FRONT	0"	21"
BACK	0"	0"
INLET DUCT	0"	1"
OUTLET DUCT	1"+	N/A

* 1" FOR THE FIRST 3 FT. OF OUTLET DUCT WHEN ELECTRIC HEATERS ARE INSTALLED; 0" AFTER THE FIRST 3 FT.

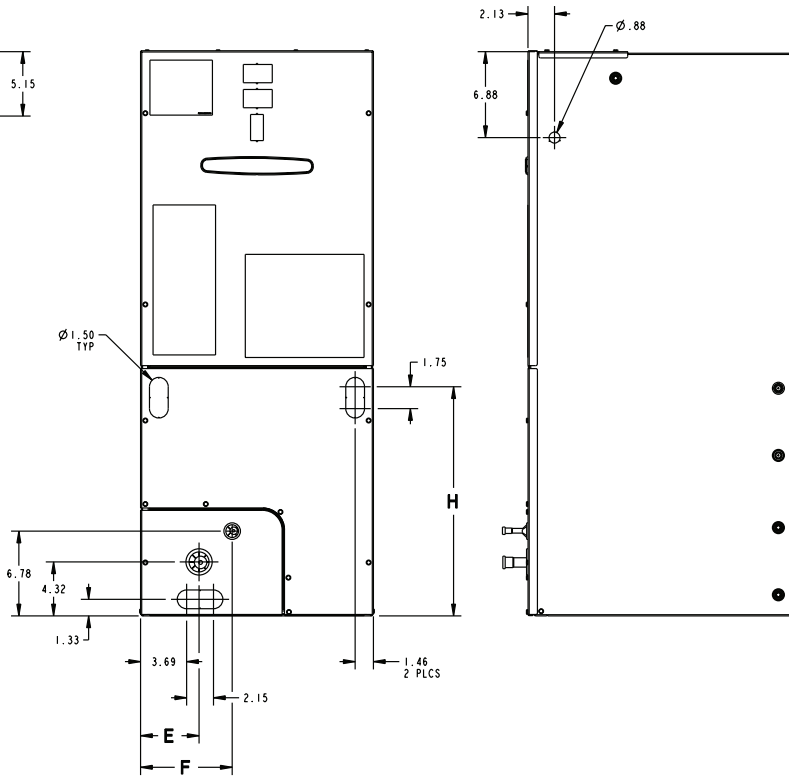

PRODUCT DIMENSIONS									
Air Handler Model	A	B	C	D	E	F	H	Flow Control	Gas Line Braze
4TVM0024, 30, 36	45.12	18.50	16.50	16.75	4.68	7.33	18.34	TXV	3/4
4TVM0042, 48, 60	51.37	23.50	21.50	21.75	7.01	9.66	24.59	TXV	7/8

All dimensions are in inches



Notes



Trane optimizes the performance of homes and buildings around the world. A business of Ingersoll Rand, the leader in creating and sustaining safe, comfortable and energy efficient environments, Trane offers a broad portfolio of advanced controls and HVAC systems, comprehensive building services, and parts. For more information, visit www.Trane.com.

Trane has a policy of continuous product and product data improvements and reserves the right to change design and specifications without notice.

©2015 Trane
22-1908-1A-EN 04 Mar 2015
Supersedes (New)

