

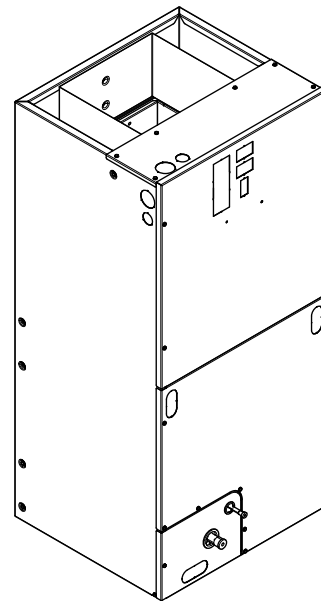

Product Data

Convertible Air Handlers 1-1/2 – 5 Ton

TEM6A0B24H21SC
TEM6A0B30H21SC
TEM6A0C36H31SC
TEM6A0C42H41SC
TEM6A0C48H41SC
TEM6B0C60H51SA



The TEM6 series air handler is designed for installation in a closet, utility room, alcove, basement, crawlspace or attic. These versatile units are applicable to air conditioning and heat pump applications. Several models are available to meet the specific requirements of the outdoor equipment. Field installed electric resistance heaters are available.



Table of Contents

Features and Benefits.....	3
Optional Equipment.....	3
Product Specifications.....	4
Heater Pressure Drop Table	6
Subcooling Adjustment	6
Subcooling Adjustment for TEM6A0C48H41 & TEM6B0C60H51.....	6
Performance and Electrical Data	7
Minimum Airflow CFM	14
Electrical Data	16
Field Wiring.....	17
TEM Convertibility.....	21
TEM6 Air Handler Dimensional Data.....	22
Outline Drawing	23



Features and Benefits

- Painted metal cabinet with captured foil face insulation
- 2% or less air leakage
- R-4.2 Insulating Value
- Multi-Position UP/Down Flow, Horizontal Left /Right
- ALL Aluminum Coil
- Electric Heaters with polarized plug connections (sold as accessory)
- R-410A Thermal Expansion Valve
- Variable Speed ECM Motor
- Low Voltage Pigtail Connections
- Draw Through Design
- Horizontal Drain Pan
- Single Color
- Fused 24V Power
- **3 year warranty**
- **10-year warranty registered**
- **Optional extended warranty available**

Optional Equipment

Accessory Number	Description	Fits Model
BAYHTR1504BRK	Electric Heater, 4KW, Breaker, 24V Control, 1 Ph	TEM6A0B24-TEM6A0D60
BAYHTR1504LUG	Electric Heater, 4KW, Lug, 24V Control, 1 Ph	TEM6A0B24-TEM6A0D60
BAYHTR1505BRK	Electric Heater, 5KW, Breaker, 24V Control, 1 Ph	TEM6A0B24-TEM6A0D60
BAYHTR1505LUG	Electric Heater, 5KW, Lug, 24V Control, 1 Ph	TEM6A0B24-TEM6A0D60
BAYHTR1508BRK	Electric Heater, 8KW, Breaker, 24V Control, 1 Ph	TEM6A0B24-TEM6A0D60
BAYHTR1508LUG	Electric Heater, 8KW, Lug, 24V Control, 1 Ph	TEM6A0B24-TEM6A0D60
BAYHTR1510BRK	Electric Heater, 10KW, Breaker, 24V Control, 1 Ph	TEM6A0B24-TEM6A0D60
BAYHTR1510LUG	Electric Heater, 10KW, Lug, 24V Control, 1 Ph	TEM6A0B24-TEM6A0D60
BAYHTR1516BRK	Electric Heater, 15KW, Breaker, 24V Control, 1 Ph	TEM6A0B24-TEM6A0D60
BAYHTR3510LUG	Electric Heater, 10KW, Lug, 24V Control, 3 Ph	TEM6A0B24-TEM6A0D60
BAYHTR3515LUG	Electric Heater, 15KW, Lug, 24V Control, 3Ph	TEM6A0B24-TEM6A0D60
BAYHTR1522BRK	Electric Heater, 20KW, Breaker, 24V Control, 1 Ph	TEM6A0B36-TEM6A0D60
BAYHTR1523BRK	Electric Heater, 20KW, Breaker, 24V Control, 1 Ph	TEM6A0B36-TEM6A0D60
BAYHTR1525BRK	Electric Heater, 25KW, Breaker, 24V Control, 1 Ph	TEM6A0B48-TEM6A0D60
BAYTEMSPFG1A/B	Supply Duct Flange Kit	TEM6A0B24-TEM6A0D60
BAYSPEKT201A	Single Point Power Entry Kit	TEM6A0B24-TEM6A0D60
TAYBASE185	Air Handler Downflow Sub-Bases	TEM6A0B24-TEM6A0B30
TAYBASE235 (TAYBASE 100)	Air Handler Downflow Sub-Bases	TEM6A0C36-TEM6A0C42
TAYBASE260	Air Handler Downflow Sub-Bases	TEM6A0D48-TEM6A0D60
BAY6TXV2442A	R-22 TXV Conversion Kit	TEM6A0B24-TEM6A0C42
BAY6TXV4860A	R-22 TXV Conversion Kit	TEM6A0D48-TEM6A0D60
BAYATXV6161C	R-22 TXV Conversion Kit	TEM6A0C48-TEM6A0C60
BAYSF1185AAA	Slim Fit Filter Box	18.5"
BAYSF1235AAA	Slim Fit Filter Box	23.5"
BAYSF1265AAA	Slim Fit Filter Box	26.5"



Product Specifications

MODEL	TEM6A0B24H21SC	TEM6A0B30H21SC	TEM6A0C36H31SC
RATED VOLTS/PH/HZ	208-230/1/60	208-230/1/60	208-230/1/60
RATINGS^(a)	See O.D. Specifications	See O.D. Specifications	See O.D. Specifications
INDOOR COIL — Type	Plate Fin	Plate Fin	Plate Fin
Rows — F.P.I.	4 - 14	4 - 14	4 - 14
Face Area (sq. ft.)	3.44	3.44	4.59
Tube Size (in.)	3/8	3/8	3/8
Refrigerant Control	TXV	TXV	TXV
Drain Conn. Size (in.) ^(b)	3/4 NPT	3/4 NPT	3/4 NPT
DUCT CONNECTIONS	See Outline Drawing	See Outline Drawing	See Outline Drawing
INDOOR FAN — Type	Centrifugal	Centrifugal	Centrifugal
Diameter-Width (In.)	11 X 8	11 X 8	11 X 8
No. Used	1	1	1
Drive - No. Speeds	Direct - 16	Direct - 16	Direct - 16
CFM vs. in. w.g.	See Fan Performance Table	See Fan Performance Table	See Fan Performance Table
No. Motors — H.P.	1 - 1/3	1 - 1/2	1 - 1/2
Motor Speed R.P.M.	Variable	Variable	Variable
Volts/Ph/Hz	208-230/1/60	208-230/1/60	208-230/1/60
F.L. Amps	2.5	4.3	4.3
FILTER			
Filter Furnished? ^(c)	No	No	No
REFRIGERANT	R-410A	R-410A	R-410A
Ref. Line Connections	Brazed	Brazed	Brazed
Coupling or Conn. Size — in. Gas	3/4	3/4	7/8
Coupling or Conn. Size — in. Liq.	3/8	3/8	3/8
DIMENSIONS	H x W x D	H x W x D	H x W x D
Crated (In.)	48-1/4 x 22-1/2 x 25-1/2	48-1/4 x 22-1/2 x 25-1/2	52-3/4 x 27-1/2 x 25-1/2
Uncrated	46-3/4 x 18-1/2 x 21-1/8	46-3/4 x 18-1/2 x 21-1/8	51-3/8 x 23-1/2 x 21-1/8
WEIGHT			
Shipping (Lbs.) / Net (Lbs.)	126/117	126/117	155/144

^(a) These Air Handlers are A.H.R.I certified with various Split System Air Conditioners and Heat Pumps (AHRI STANDARD 210/240). Refer to the Split System Outdoor Unit Product Data Guides for performance data.

^(b) 3/4" Male Plastic Pipe (Ref: ASTM 1785-76)

^(c) Remote filter required.

Product Specifications

MODEL	TEM6A0C42H41SC	TEM6A0C48H41SC	TEM6B0C60H51SA
RATED VOLTS/PH/HZ	208-230/1/60	208-230/1/60	208-230/1/60
RATINGS^(a)	See O.D. Specifications	See O.D. Specifications	See O.D. Specifications
INDOOR COIL — Type	Plate Fin	Plate Fin	Plate Fin
Rows — F.P.I.	4 - 14	3 - 16	3 - 16
Face Area (sq. ft.)	4.59	7.9	7.9
Tube Size (in.)	3/8	3/8	3/8
Refrigerant Control	TXV	TXV	TXV
Drain Conn. Size (in.) ^(b)	3/4 NPT	3/4 NPT	3/4 NPT
DUCT CONNECTIONS	See Outline Drawing	See Outline Drawing	See Outline Drawing
INDOOR FAN — Type	Centrifugal	Centrifugal	Centrifugal
Diameter-Width (In.)	11 X 8	11 X 11	11 X 11
No. Used	1	1	1
Drive - No. Speeds	Direct - 16	Direct - 16	Direct - 16
CFM vs. in. w.g.	See Fan Performance Table	See Fan Performance Table	See Fan Performance Table
No. Motors — H.P.	1 - 1/2	1 - 3/4	1 - 3/4
Motor Speed R.P.M.	Variable	Variable	Variable
Volts/Ph/Hz	208-230/1/60	208-230/1/60	208-230/1/60
F.L. Amps	4.3	6.8	6.8
FILTER			
Filter Furnished? ^(c)	No	No	No
REFRIGERANT	R-410A	R-410A	R-410A
Ref. Line Connections	Brazed	Brazed	Brazed
Coupling or Conn. Size — in. Gas	7/8	7/8	7/8
Coupling or Conn. Size — in. Liq.	3/8	3/8	3/8
DIMENSIONS	H x W x D	H x W x D	H x W x D
Crated (In.)	52-3/4 x 27-1/2 x 25-1/2	57-11/16 x 27-1/2 x 25-1/2	57-11/16 x 27-1/2 x 25-1/2
Uncrated	51-3/8 x 23-1/2 x 21-1/8	57-3/8 x 23-1/2 x 21-1/8	57-3/8 x 23-1/2 x 21-1/8
WEIGHT			
Shipping (Lbs.) / Net (Lbs.)	155/144	185/174	185/174

^(a) These Air Handlers are A.H.R.I certified with various Split System Air Conditioners and Heat Pumps (AHRI STANDARD 210/240). Refer to the Split System Outdoor Unit Product Data Guides for performance data.

^(b) 3/4" Male Plastic Pipe (Ref: ASTM 1785-76)

^(c) Remote filter required.



Heater Pressure Drop Table

Airflow CFM	Number of Racks				Heater Racks	
	1	2	3	4	Heater Model	No. of Racks
	Air Pressure Drop — Inches W.G.					
1800	0.02	0.04	0.06	0.14	BAYHTR1504	1
1700	0.02	0.04	0.06	0.14	BAYHTR1505	1
1600	0.02	0.04	0.06	0.13	BAYHTR1508	2
1500	0.02	0.04	0.06	0.12	BAYHTR1510	2
1400	0.02	0.04	0.06	0.12	BAYHTR1517	3
1300	0.02	0.04	0.05	0.11	BAYHTR3510	3
1200	0.01	0.04	0.05	0.10	BAYHTR3517	3
1100	0.01	0.03	0.05	0.09	BAYHTR1523	4
1000	0.01	0.03	0.04	0.09	BAYHTR1525	4
900	0.01	0.03	0.04	0.08		
800	0.01	0.03				
700	0.01	0.02				
600	0.01	0.02				

Subcooling Adjustment

System Matched with:	Indoor Unit Model No.	Outdoor Model No.	Subcooling
16 SEER HP — 2 ton	TEM6A0C36H31	4TWR6024H1000A 4TWX6024H1000A 4A6H6024H1000A	13 Degrees
15 SEER HP — 2 ton	TEM6A0B24H21 TEM6A0B30H21	4TWR5024G1000A 4A6H5024G1000A	14 Degrees
15 SEER HP — 3 ton	TEM6A0B30H21 TEM6A0C36H31 TEM6A0C42H41	4TWR5036G1000A 4A6H5036G1000A	14 Degrees

All other matches must be charged per the nameplate charging instructions

Subcooling Adjustment for TEM6A0C48H41 & TEM6B0C60H51

Sub-Cooling Charge Specification For AHRI Rated Performance		
OD Equipment	Up Flow / Horizontal	Down Flow
AC UNIT	OD Name Plate	OD Name Plate
HP UNIT ≤ 3.5 Tons	OD Name Plate	OD Name Plate + 4 Degrees
HP UNIT = 4 and 5 Tons	OD Name Plate	OD Name Plate



Performance and Electrical Data

Table 1. Air Flow Performance

TEM6A0B24H21SC COOLING AIRFLOW PERFORMANCE, WET COIL, NO FILTER, NO HEATER												
OUTDOOR UNIT SIZE (TONS)	SPEED SETTING	AIRFLOW SETTING	DIP SWITCH SETTING				AIRFLOW POWER	EXTERNAL STATIC PRESSURE				
			SW1	SW2	SW3	SW4		0.1	0.3	0.5	0.7	0.9
1.5	LOW	353 CFM/ton	ON	ON	OFF	ON	CFM Watts	533 52	497 78	461 104	425 130	390 157
	NORMAL	401 CFM/ton	ON	ON	OFF	OFF	CFM Watts	611 65	580 95	548 125	517 155	486 185
	HIGH	451 CFM/ton	ON	ON	ON	OFF	CFM Watts	684 81	668 115	644 148	611 182	570 215
2	LOW	343 CFM/ton	OFF	ON	OFF	ON	CFM Watts	687 82	672 115	648 149	614 182	571 215
	NORMAL	390 CFM/ton	OFF	ON	OFF	OFF	CFM Watts	789 104	798 145	780 183	735 216	663 246
	HIGH	439 CFM/ton	OFF	ON	ON	OFF	CFM Watts	884 135	887 177	882 230	845 274	751 290
2.5	LOW	300 CFM/ton	ON	OFF	OFF	ON	CFM Watts	752 92	749 123	729 167	691 211	636 241
	NORMAL ^(a)	340 CFM/ton	ON	OFF	OFF	OFF	CFM Watts	859 128	861 172	863 211	830 242	727 268
	HIGH	383 CFM/ton	ON	OFF	ON	OFF	CFM Watts	963 172	973 223	995 263	967 291	844 308

^(a) Factory Default Setting

Table 2. Air Flow Performance

TEM6A0B24H21SC HEATING AIRFLOW PERFORMANCE, NO FILTER, NO HEATER												
OUTDOOR UNIT SIZE (TONS)	SPEED SETTING	AIRFLOW SETTING	DIP SWITCH SETTING				AIRFLOW POWER	EXTERNAL STATIC PRESSURE				
			SW1	SW2	SW3	SW4		0.1	0.3	0.5	0.7	0.9
1.5	LOW	394 CFM/ton	ON	ON	OFF	ON	CFM Watts	599 58	571 88	539 117	502 146	462 175
	NORMAL	448 CFM/ton	ON	ON	OFF	OFF	CFM Watts	680 72	665 109	641 145	610 178	572 209
	HIGH	493 CFM/ton	ON	ON	ON	OFF	CFM Watts	748 89	746 118	682 163	545 208	326 240
2	LOW	393 CFM/ton	OFF	ON	OFF	ON	CFM Watts	785 97	790 128	773 175	735 223	674 253
	NORMAL	446 CFM/ton	OFF	ON	OFF	OFF	CFM Watts	904 131	902 179	912 219	894 253	809 281
	HIGH	491 CFM/ton	OFF	ON	ON	OFF	CFM Watts	980 167	972 216	990 268	974 308	863 324
2.5	LOW	350 CFM/ton	ON	OFF	OFF	ON	CFM Watts	866 125	870 162	866 215	833 263	750 286
	NORMAL ^(a)	398 CFM/ton	ON	OFF	OFF	OFF	CFM Watts	995 171	988 222	1005 271	986 309	872 325
	HIGH	437 CFM/ton	ON	OFF	ON	OFF	CFM Watts	1099 220	1086 274	1098 328	1065 362	918 353

^(a) Factory Default Setting



Performance and Electrical Data

Table 3. Air Flow Performance

TEM6A0B30H21SC COOLING AIRFLOW PERFORMANCE, WET COIL, NO FILTER, NO HEATER												
OUTDOOR UNIT SIZE (TONS)	SPEED SETTING	AIRFLOW SETTING	DIP SWITCH SETTING				AIRFLOW POWER	EXTERNAL STATIC PRESSURE				
			SW1	SW2	SW3	SW4		0.1	0.3	0.5	0.7	0.9
1.5	LOW	353 CFM/ton	ON	ON	OFF	ON	CFM Watts	533 52	497 78	461 104	425 130	390 157
	NORMAL	401 CFM/ton	ON	ON	OFF	OFF	CFM Watts	611 65	580 95	548 125	517 155	486 185
	HIGH	451 CFM/ton	ON	ON	ON	OFF	CFM Watts	684 81	668 115	644 148	611 182	570 215
2	LOW	343 CFM/ton	OFF	ON	OFF	ON	CFM Watts	687 82	672 115	648 149	614 182	571 215
	NORMAL	390 CFM/ton	OFF	ON	OFF	OFF	CFM Watts	789 104	798 145	780 183	735 216	663 246
	HIGH	439 CFM/ton	OFF	ON	ON	OFF	CFM Watts	884 135	887 177	882 230	845 274	751 290
2.5	LOW	300 CFM/ton	ON	OFF	OFF	ON	CFM Watts	752 92	749 123	729 167	691 211	636 241
	NORMAL	340 CFM/ton	ON	OFF	OFF	OFF	CFM Watts	859 128	861 172	863 211	830 242	727 268
	HIGH	383 CFM/ton	ON	OFF	ON	OFF	CFM Watts	963 172	973 223	995 263	967 291	844 308
3	LOW	310 CFM/ton	OFF	OFF	OFF	ON	CFM Watts	913 119	947 172	962 233	938 297	883 364
	NORMAL ^(a)	330 CFM/ton	OFF	OFF	OFF	OFF	CFM Watts	967 138	1004 194	1022 258	1000 326	947 397

^(a) Factory Default Setting

Table 4. Air Flow Performance

TEM6A0B30H21SC HEATING AIRFLOW PERFORMANCE, NO FILTER, NO HEATER												
OUTDOOR UNIT SIZE (TONS)	SPEED SETTING	AIRFLOW SETTING	DIP SWITCH SETTING				AIRFLOW POWER	EXTERNAL STATIC PRESSURE				
			SW1	SW2	SW3	SW4		0.1	0.3	0.5	0.7	0.9
1.5	LOW	394 CFM/ton	ON	ON	OFF	ON	CFM Watts	599 58	571 88	539 117	502 146	462 175
	NORMAL	448 CFM/ton	ON	ON	OFF	OFF	CFM Watts	680 72	665 109	641 145	610 178	572 209
	HIGH	493 CFM/ton	ON	ON	ON	OFF	CFM Watts	748 89	746 118	682 163	545 208	326 240
2	LOW	393 CFM/ton	OFF	ON	OFF	ON	CFM Watts	785 97	790 128	773 175	735 223	674 253
	NORMAL	446 CFM/ton	OFF	ON	OFF	OFF	CFM Watts	904 131	902 179	912 219	894 253	809 281
	HIGH	491 CFM/ton	OFF	ON	ON	OFF	CFM Watts	980 167	972 216	990 268	974 308	863 324
2.5	LOW	350 CFM/ton	ON	OFF	OFF	ON	CFM Watts	866 125	870 162	866 215	833 263	750 286
	NORMAL	398 CFM/ton	ON	OFF	OFF	OFF	CFM Watts	995 171	988 222	1005 271	986 309	872 325
	HIGH	437 CFM/ton	ON	OFF	ON	OFF	CFM Watts	1099 220	1086 274	1098 328	1065 362	918 353
3	LOW	325 CFM/ton	OFF	OFF	OFF	ON	CFM Watts	953 133	990 188	1007 251	985 318	931 389
	NORMAL ^(a)	346 CFM/ton	OFF	OFF	OFF	OFF	CFM Watts	1010 154	1049 212	1066 279	1047 350	1000 426

^(a) Factory Default Setting

Table 5. Air Flow Performance

TEM6A0C36H31SC, TEM6A0C42H41SC COOLING AIRFLOW PERFORMANCE, WET COIL, NO FILTER, NO HEATER												
OUTDOOR UNIT SIZE (TONS)	SPEED SETTING	AIRFLOW SETTING	DIP SWITCH SETTING				AIRFLOW POWER	EXTERNAL STATIC PRESSURE				
			SW1	SW2	SW3	SW4		0.1	0.3	0.5	0.7	0.9
2.5	LOW	300 CFM/ton	ON	ON	OFF	ON	CFM Watts	761 63	755 98	719 131	654 163	560 193
	NORMAL	341 CFM/ton	ON	ON	OFF	OFF	CFM Watts	862 82	861 120	834 158	781 196	700 235
	HIGH	384 CFM/ton	ON	ON	ON	OFF	CFM Watts	962 106	963 147	948 190	915 234	863 279
3	LOW	319 CFM/ton	OFF	ON	OFF	ON	CFM Watts	961 106	962 147	947 189	914 233	862 279
	NORMAL	363 CFM/ton	OFF	ON	OFF	OFF	CFM Watts	1092 146	1093 192	1082 240	1060 288	1026 337
	HIGH	408 CFM/ton	OFF	ON	ON	OFF	CFM Watts	1231 196	1231 249	1221 301	1203 353	1175 404
3.5	LOW	315 CFM/ton	ON	OFF	OFF	ON	CFM Watts	1104 150	1105 197	1094 245	1072 293	1039 343
	NORMAL	357 CFM/ton	ON	OFF	OFF	OFF	CFM Watts	1258 209	1258 263	1248 317	1229 369	1201 421
	HIGH	402 CFM/ton	ON	OFF	ON	OFF	CFM Watts	1418 286	1415 347	1401 406	1379 462	1348 516
4	LOW	308 CFM/ton	OFF	OFF	OFF	ON	CFM Watts	1238 199	1238 253	1229 306	1210 357	1182 408
	NORMAL ^(a)	350 CFM/ton	OFF	OFF	OFF	OFF	CFM Watts	1412 282	1410 344	1398 404	1378 462	1349 517
	HIGH	394 CFM/ton	OFF	OFF	ON	OFF	CFM Watts	1570 393	1528 436	1473 466	1406 483	1326 488

^(a) Factory Default Setting

Table 6. Air Flow Performance

TEM6A0C36H31SC, TEM6A0C42H41SC HEATING AIRFLOW PERFORMANCE, NO FILTER, NO HEATER												
OUTDOOR UNIT SIZE (TONS)	SPEED SETTING	AIRFLOW SETTING	DIP SWITCH SETTING				AIRFLOW POWER	EXTERNAL STATIC PRESSURE				
			SW1	SW2	SW3	SW4		0.1	0.3	0.5	0.7	0.9
2.5	LOW	341 CFM/ton	ON	ON	OFF	ON	CFM Watts	860 77	863 115	838 154	788 193	707 232
	NORMAL	379 CFM/ton	ON	ON	OFF	OFF	CFM Watts	949 98	953 138	937 180	906 224	852 269
	HIGH	417 CFM/ton	ON	ON	ON	OFF	CFM Watts	1042 122	1046 166	1036 212	1015 259	980 308
3	LOW	381 CFM/ton	OFF	ON	OFF	ON	CFM Watts	1147 154	1149 203	1141 253	1123 303	1094 353
	NORMAL	424 CFM/ton	OFF	ON	OFF	OFF	CFM Watts	1277 204	1279 259	1272 314	1255 368	1228 421
	HIGH	466 CFM/ton	OFF	ON	ON	OFF	CFM Watts	1409 260	1409 323	1401 383	1384 442	1357 500
3.5	LOW	348 CFM/ton	ON	OFF	OFF	ON	CFM Watts	1222 180	1224 232	1216 285	1200 336	1174 388
	NORMAL	386 CFM/ton	ON	OFF	OFF	OFF	CFM Watts	1361 240	1362 300	1354 358	1337 415	1310 471
	HIGH	425 CFM/ton	ON	OFF	ON	OFF	CFM Watts	1497 316	1478 372	1449 420	1408 461	1356 494
4	LOW	338 CFM/ton	OFF	OFF	OFF	ON	CFM Watts	1360 239	1361 299	1353 358	1336 415	1309 470
	NORMAL ^(a)	375 CFM/ton	OFF	OFF	OFF	OFF	CFM Watts	1511 325	1489 380	1456 426	1412 464	1355 493
	HIGH	413 CFM/ton	OFF	OFF	ON	OFF	CFM Watts	1659 420	1605 463	1535 488	1450 494	1349 483

^(a) Factory Default Setting



Performance and Electrical Data

Table 7. Air Flow Performance

TEM6A0C48H41SC, TEM6B0C60H51SA COOLING AIRFLOW PERFORMANCE, WET COIL, NO FILTER, NO HEATER												
OUTDOOR UNIT SIZE (TONS)	SPEED SETTING	AIRFLOW SETTING	DIP SWITCH SETTING				AIRFLOW POWER	EXTERNAL STATIC PRESSURE				
			SW1	SW2	SW3	SW4		0.1	0.3	0.5	0.7	0.9
3	LOW	324 CFM/ton	ON	ON	OFF	ON	CFM Watts	991 89	985 133	974 186	984 237	994 303
	NORMAL	368 CFM/ton	ON	ON	OFF	OFF	CFM Watts	1120 118	1119 167	1110 224	1116 279	1122 333
	HIGH	423 CFM/ton	ON	ON	ON	OFF	CFM Watts	1282 162	1286 219	1281 280	1280 343	1282 402
3.5	LOW	314 CFM/ton	OFF	ON	OFF	ON	CFM Watts	1116 117	1114 165	1105 222	1111 277	1117 331
	NORMAL	357 CFM/ton	OFF	ON	OFF	OFF	CFM Watts	1263 156	1266 212	1261 273	1261 334	1263 392
	HIGH	411 CFM/ton	OFF	ON	ON	OFF	CFM Watts	1449 218	1458 287	1456 352	1449 421	1447 496
4	LOW	298 CFM/ton	ON	OFF	OFF	ON	CFM Watts	1207 140	1208 193	1201 252	1203 311	1207 366
	NORMAL	339 CFM/ton	ON	OFF	OFF	OFF	CFM Watts	1368 190	1374 252	1370 315	1367 381	1367 448
	HIGH	389 CFM/ton	ON	OFF	ON	OFF	CFM Watts	1564 264	1577 343	1577 411	1567 484	1561 570
5	LOW	305 CFM/ton	OFF	OFF	OFF	ON	CFM Watts	1534 251	1545 328	1545 394	1536 467	1531 550
	NORMAL (a)	347 CFM/ton	OFF	OFF	OFF	OFF	CFM Watts	1740 344	1758 444	1762 518	1745 594	1734 684
	HIGH (b)	399 CFM/ton	OFF	OFF	ON	OFF	CFM Watts	1995 484	2022 629	2030 717	2005 783	1987 828

(a) Factory Default Setting

(b) Airflow must not exceed 1800 cfm in horizontal right, horizontal left, and downflow applications due to condensate blowoff. The 5 ton high tap shall not be used in these applications.

Table 8. Air Flow Performance

TEM6A0C48H41SC, TEM6B0C60H51SA HEATING AIRFLOW PERFORMANCE, NO FILTER, NO HEATER												
OUTDOOR UNIT SIZE (TONS)	SPEED SETTING	AIRFLOW SETTING	DIP SWITCH SETTING				AIRFLOW POWER	EXTERNAL STATIC PRESSURE				
			SW1	SW2	SW3	SW4		0.1	0.3	0.5	0.7	0.9
3	LOW	360 CFM/ton	ON	ON	OFF	ON	CFM Watts	1097 112	1094 160	1086 216	1092 271	1099 326
	NORMAL	400 CFM/ton	ON	ON	OFF	OFF	CFM Watts	1215 142	1216 196	1210 255	1211 314	1215 369
	HIGH	440 CFM/ton	ON	ON	ON	OFF	CFM Watts	1333 178	1338 238	1333 300	1331 365	1332 428
3.5	LOW	348 CFM/ton	OFF	ON	OFF	ON	CFM Watts	1232 147	1234 202	1228 261	1229 322	1233 377
	NORMAL	387 CFM/ton	OFF	ON	OFF	OFF	CFM Watts	1366 189	1373 252	1369 314	1366 381	1365 447
	HIGH	426 CFM/ton	OFF	ON	ON	OFF	CFM Watts	1500 238	1511 311	1510 377	1502 449	1498 529
4	LOW	338 CFM/ton	ON	OFF	OFF	ON	CFM Watts	1364 188	1370 251	1366 313	1363 379	1363 446
	NORMAL	375 CFM/ton	ON	OFF	OFF	OFF	CFM Watts	1509 241	1520 315	1519 382	1511 453	1506 535
	HIGH	413 CFM/ton	ON	OFF	ON	OFF	CFM Watts	1659 305	1674 395	1676 466	1662 541	1654 632
5	LOW	326 CFM/ton	OFF	OFF	OFF	ON	CFM Watts	1637 295	1652 383	1653 453	1641 528	1632 618
	NORMAL (a)	362 CFM/ton	OFF	OFF	OFF	OFF	CFM Watts	1814 381	1834 493	1839 570	1820 645	1807 730
	HIGH	398 CFM/ton	OFF	OFF	ON	OFF	CFM Watts	1990 481	2017 625	2025 713	2000 779	1982 826

(a) Factory Default Setting

Table 9. Electrical Data

TEM6A0B24H21SC HEATER DATA											
Heater Model No.	No. of Circuits/ Phases	240 Volt					208 Volt				
		Capacity		Heater Amps per Circuit	Minimum Circuit Ampacity	Maximum Overload Protection	Capacity		Heater Amps per Circuit	Minimum Circuit Ampacity	Maximum Overload Protection
		kW	BTUH				kW	BTUH			
No Heater				2.5 *	3	15			2.5 *	3	15
BAYHTR1504BRK BAYHTR1504LUG	1/1	3.84	13100	16.0	23	25	2.88	9800	13.8	20	20
BAYHTR1505BRK BAYHTR1505LUG	1/1	4.80	16400	20.0	28	30	3.60	12300	17.3	25	25
BAYHTR1508BRK BAYHTR1508LUG	1/1	7.68	26200	32.0	43	45	5.76	19700	27.7	38	40
BAYHTR1510BRK BAYHTR1510LUG	1/1	9.60	32800	40.0	53	60	7.20	24600	34.6	46	50
BAYHTR1517BRK Circuit 1 ^(a)	2/1	9.60	32800	40.0	53	60	7.20	24600	34.6	46	50
BAYHTR1517BRK Circuit 2		4.80	16400	20.0	25	25	3.60	12300	17.3	22	25
BAYHTR3510LUG	1/3	9.60	32800	23.1	32	35	7.20	24600	20.0	28	30
BAYHTR3517LUG	1/3	14.40	49100	34.6	46	50	10.80	36900	30.0	40	45

* = Motor Amps

^(a) MCA and MOP for circuit 1 contains the motor amps

Table 10. Electrical Data

TEM6A0B30H21SC HEATER DATA											
Heater Model No.	No. of Circuits/ Phases	240 Volt					208 Volt				
		Capacity		Heater Amps per Circuit	Minimum Circuit Ampacity	Maximum Overload Protection	Capacity		Heater Amps per Circuit	Minimum Circuit Ampacity	Maximum Overload Protection
		kW	BTUH				kW	BTUH			
No Heater				4.3 *	5	15			4.3 *	5	15
BAYHTR1504BRK BAYHTR1504LUG	1/1	3.84	13100	16.0	25	25	2.88	9800	13.8	23	25
BAYHTR1505BRK BAYHTR1505LUG	1/1	4.80	16400	20.0	30	30	3.60	12300	17.3	27	30
BAYHTR1508BRK BAYHTR1508LUG	1/1	7.68	26200	32.0	45	45	5.76	19700	27.7	40	40
BAYHTR1510BRK BAYHTR1510LUG	1/1	9.60	32800	40.0	55	60	7.20	24600	34.6	49	50
BAYHTR1517BRK Circuit 1 ^(a)	2/1	9.60	32800	40.0	55	60	7.20	24600	34.6	49	50
BAYHTR1517BRK Circuit 2		4.80	16400	20.0	25	25	3.60	12300	17.3	22	25
BAYHTR3510LUG	1/3	9.60	32800	23.1	34	35	7.20	24600	20.0	30	30
BAYHTR3517LUG	1/3	14.40	49100	34.6	48	50	10.80	36900	30.0	42	45

* = Motor Amps

^(a) MCA and MOP for circuit 1 contains the motor amps



Performance and Electrical Data

Table 11. Electrical Data

TEM6A0C36H31SC, TEM6A0C42H41SC HEATER DATA											
Heater Model No.	No. of Circuits/ Phases	240 Volt					208 Volt				
		Capacity		Heater Amps per Circuit	Minimum Circuit Ampacity	Maximum Overload Protection	Capacity		Heater Amps per Circuit	Minimum Circuit Ampacity	Maximum Overload Protection
		kW	BTUH				kW	BTUH			
No Heater				4.3 *	5	15			4.3 *	5	15
BAYHTR1504BRK BAYHTR1504LUG	1/1	3.84	13100	16.0	25	25	2.88	9800	13.8	23	25
BAYHTR1505BRK BAYHTR1505LUG	1/1	4.80	16400	20.0	30	30	3.60	12300	17.3	27	30
BAYHTR1508BRK BAYHTR1508LUG	1/1	7.68	26200	32.0	45	45	5.76	19700	27.7	40	40
BAYHTR1510BRK BAYHTR1510LUG	1/1	9.60	32800	40.0	55	60	7.20	24600	34.6	49	50
BAYHTR1517BRK Circuit 1 ^(a)	2/1	9.60	32800	40.0	55	60	7.20	24600	34.6	49	50
BAYHTR1517BRK Circuit 2		4.80	16400	20.0	25	25	3.60	12300	17.3	22	25
BAYHTR1523BRK Circuit 1 ^(a)	2/1	9.60	32800	40.0	55	60	7.20	24600	34.6	49	50
BAYHTR1523BRK Circuit 2		9.60	32800	40.0	50	50	7.20	24600	34.6	43	45
BAYHTR3510LUG	1/3	9.60	32800	23.1	34	35	7.20	24600	20.0	30	30
BAYHTR3517LUG	1/3	14.40	49100	34.6	48	50	10.80	36900	30.0	42	45

* = Motor Amps

^(a) MCA and MOP for circuit 1 contains the motor amps

Table 12. Electrical Data

TEM6A0C48H41SC, TEM6B0C60H51SA HEATER DATA											
Heater Model No.	No. of Circuits/ Phases	240 Volt					208 Volt				
		Capacity		Heater Amps per Circuit	Minimum Circuit Ampacity	Maximum Overload Protection	Capacity		Heater Amps per Circuit	Minimum Circuit Ampacity	Maximum Overload Protection
		kW	BTUH				kW	BTUH			
No Heater				6.8 *	9	15			6.8 *	9	15
BAYHTR1504BRK BAYHTR1504LUG	1/1	3.84	13100	16.0	29	30	2.88	9800	13.8	26	30
BAYHTR1505BRK BAYHTR1505LUG	1/1	4.80	16400	20.0	34	35	3.60	12300	17.3	30	30
BAYHTR1508BRK BAYHTR1508LUG	1/1	7.68	26200	32.0	49	50	5.76	19700	27.7	43	45
BAYHTR1510BRK BAYHTR1510LUG	1/1	9.60	32800	40.0	59	60	7.20	24600	34.6	52	60
BAYHTR1517BRK Circuit 1 ^(a)	2/1	9.60	32800	40.0	59	60	7.20	24600	34.6	52	60
BAYHTR1517BRK Circuit 2		4.80	16400	20.0	25	25	3.60	12300	17.3	22	25
BAYHTR1523BRK Circuit 1 ^(a)	2/1	9.60	32800	40.0	59	60	7.20	24600	34.6	52	60
BAYHTR1523BRK Circuit 2		9.60	32800	40.0	50	50	7.20	24600	34.6	43	45
BAYHTR1525BRK Circuit 1 ^(a)	4/1	6.00	20500	25.0	40	40	4.50	15400	21.6	36	40
BAYHTR1525BRK Circuit 2		6.00	20500	25.0	31	35	4.50	15400	21.6	27	30
BAYHTR1525BRK Circuit 3		6.00	20500	25.0	31	35	4.50	15400	21.6	27	30
BAYHTR1525BRK Circuit 4		6.00	20500	25.0	31	35	4.50	15400	21.6	27	30
BAYHTR3510LUG	1/3	9.60	32800	23.1	36	40	7.20	24600	20.0	33	35
BAYHTR3517LUG	1/3	14.40	49100	34.6	51	60	10.80	36900	30.0	45	45

* = Motor Amps

^(a) MCA and MOP for circuit 1 contains the motor amps



Minimum Airflow CFM

TEM6A0B24H21SC, TEM6A0B30H21SC		
Heater	Minimum Heater Airflow CFM	
	With Heat Pump	Without Heat Pump
BAYHTR1504BRK, BAYHTR1504LUG BAYHTR1505BRK, BAYHTR1505LUG	660	600
BAYHTR1508BRK, BAYHTR1508LUG	780	600
BAYHTR1510BRK, BAYHTR1510LUG	780	600
BAYHTR1517BRK	1050	850
BAYHTR3510LUG	780	600
BAYHTR3517LUG	900	850

TEM6A0C36H31SC, TEM6A0C42H41SC		
Heater	Minimum Heater Airflow CFM	
	With Heat Pump	Without Heat Pump
BAYHTR1504BRK, BAYHTR1504LUG BAYHTR1505BRK, BAYHTR1505LUG	875	675
BAYHTR1508BRK, BAYHTR1508LUG	950	820
BAYHTR1510BRK, BAYHTR1510LUG	1000	820
BAYHTR1517BRK	1000	820
BAYHTR3510LUG	875	820
BAYHTR3517LUG	1000	950
BAYHTR1523BRK	1300	1140

TEM6A0C48H41SC, TEM6B0C60H51SA		
Heater	Minimum Heater Airflow CFM	
	With Heat Pump	Without Heat Pump
BAYHTR1504BRK, BAYHTR1504LUG BAYHTR1505BRK, BAYHTR1505LUG	1200	975
BAYHTR1508BRK, BAYHTR1508LUG	1350	975
BAYHTR1510BRK, BAYHTR1510LUG	1350	975
BAYHTR1517BRK	1365	975
BAYHTR3510LUG	1300	975
BAYHTR3517LUG	1365	1120
BAYHTR1523BRK	1365	1300
BAYHTR1525BRK	1810	1505



Minimum Airflow CFM

TEM6A0B24H21SC, TEM6A0B30H21SC Airflow Performance with Auxiliary Heat				
Airflow Settings	Dip Switch Settings		Nominal Airflow	See following tables for heater application: - Pressure Drop for Electrical Heaters - Minimum Heating Airflow Matrix (on unit nameplates)
	Switch 7	Switch 8		
Low	ON	ON	601	
Med-Lo	OFF	ON	661	
Med-Hi	ON	OFF	781	
High	OFF	OFF	973	

TEM6A0C36H31SC, TEM6A0C42H41SC Airflow Performance with Auxiliary Heat				
Airflow Settings	Dip Switch Settings		Nominal Airflow	See following tables for heater application: - Pressure Drop for Electrical Heaters - Minimum Heating Airflow Matrix (on unit nameplates)
	Switch 7	Switch 8		
Low	ON	ON	696	
Med-Lo	OFF	ON	825	
Med-Hi	ON	OFF	1150	
High	OFF	OFF	1298	

TEM6A0C48H41SC, TEM6B0C60H51SA Airflow Performance with Auxiliary Heat				
Airflow Settings	Dip Switch Settings		Nominal Airflow	See following tables for heater application: - Pressure Drop for Electrical Heaters - Minimum Heating Airflow Matrix (on unit nameplates)
	Switch 7	Switch 8		
Low	ON	ON	1000	
Med-Lo	OFF	ON	1130	
Med-Hi	ON	OFF	1354	
High	OFF	OFF	1596	

Electrical Data

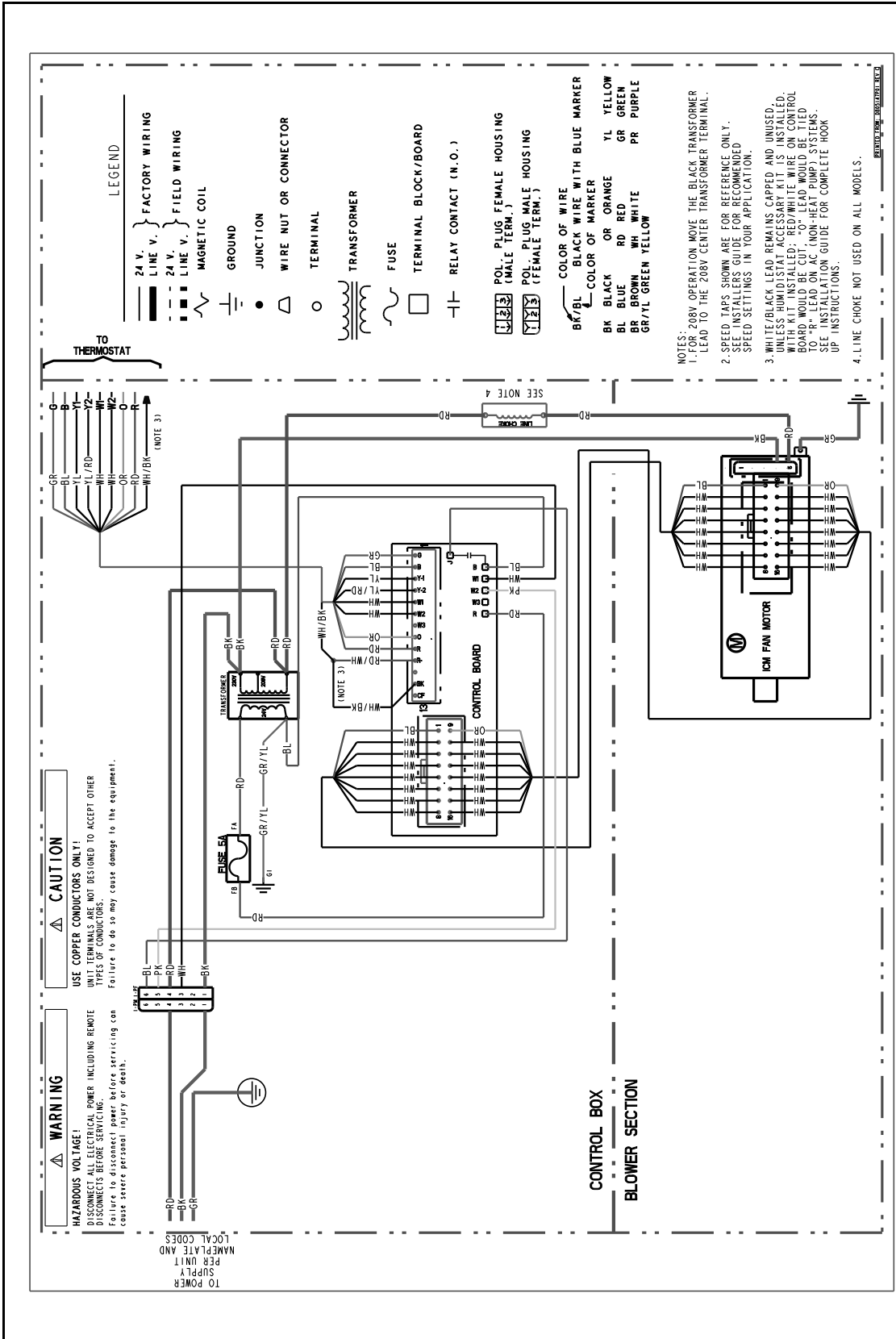



Field Wiring

Single Stage, Cooling Only

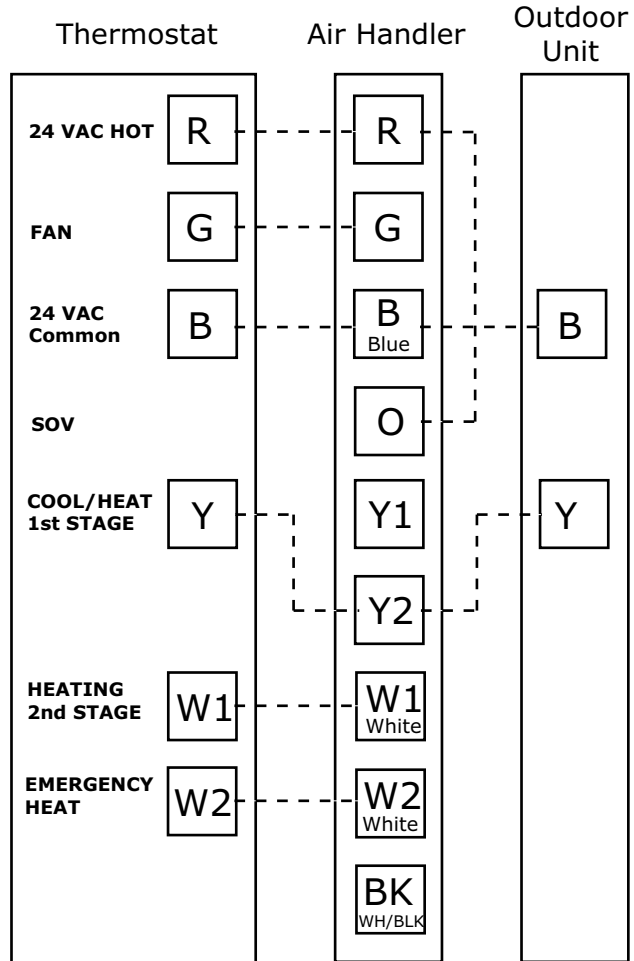

1. * Units with pigtailed require wirenuts for connections.
2. Cap all unused wires.
3. For BK enabled comfort control, do not connect Y1 or Y2 at the air handler
4. For BK enabled comfort control, cut the jumper wire between R and BK on the control board. See wiring schematic for details.
5. In AC systems for multiple stages of electric heat, jumper W1 and W2 together if comfort control has only one stage of heat.

Single Stage, HP

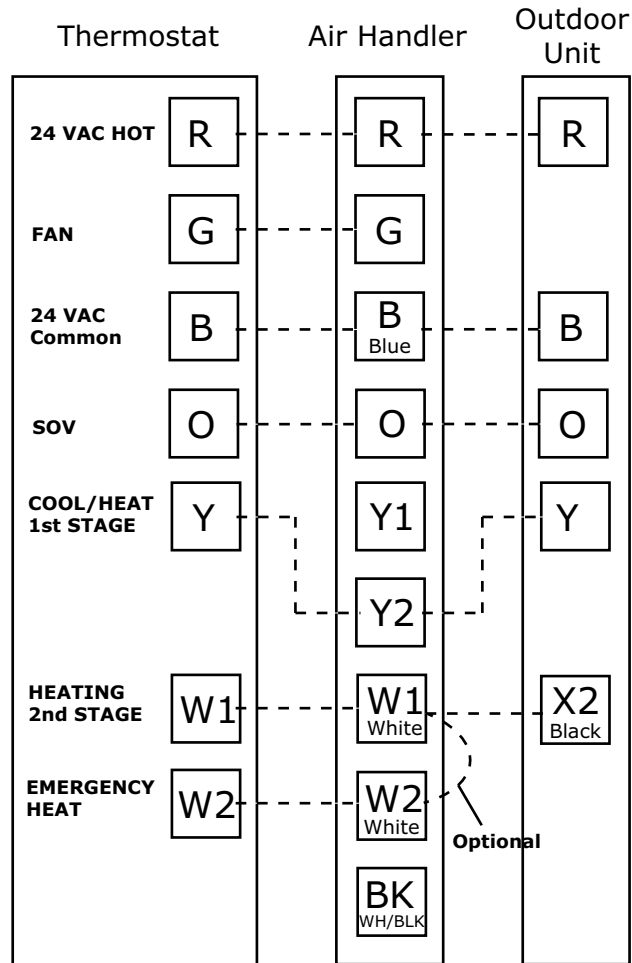

1. * Units with pigtailed require wirenuts for connections.
2. Cap all unused wires.
3. For BK enabled comfort control, do not connect Y1 or Y2 at the air handler
4. For BK enabled comfort control, cut the jumper wire between R and BK on the control board. See wiring schematic for details.
5. In systems for multiple stages of electric heat, jumper W1 and W2 together if comfort control has only one stage of heat.

2 Stage, 2 Step, Cooling Only

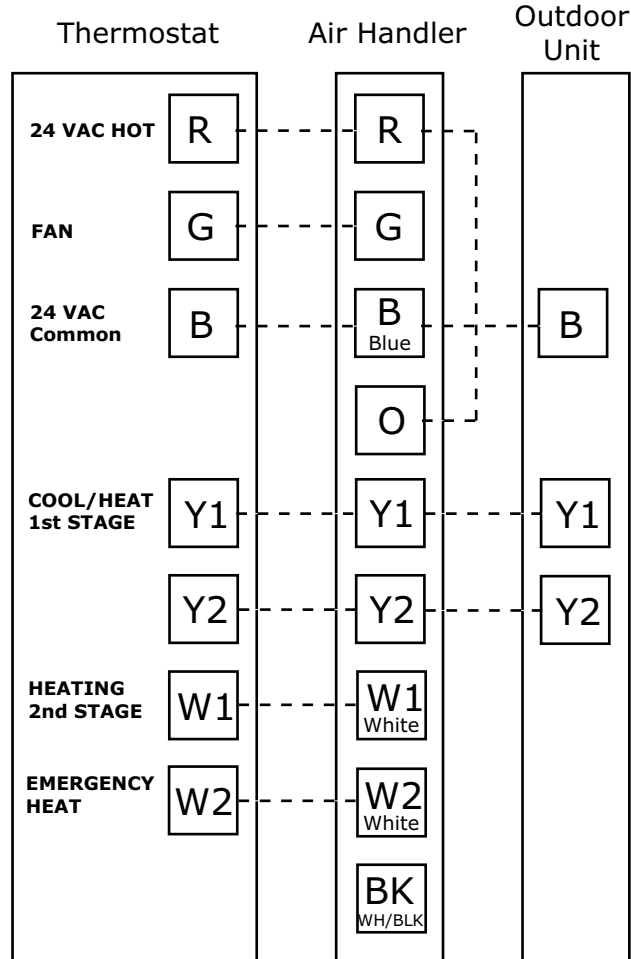

1. * Units with pigtailed require wirenuts for connections.
2. Cap all unused wires.
3. For BK enabled comfort control, do not connect Y1 or Y2 at the air handler
4. For BK enabled comfort control, cut the jumper wire between R and BK on the control board. See wiring schematic for details.
5. In AC systems for multiple stages of electric heat, jumper W1 and W2 together if comfort control has only one stage of heat.

2 Stage, 2 Step, HP

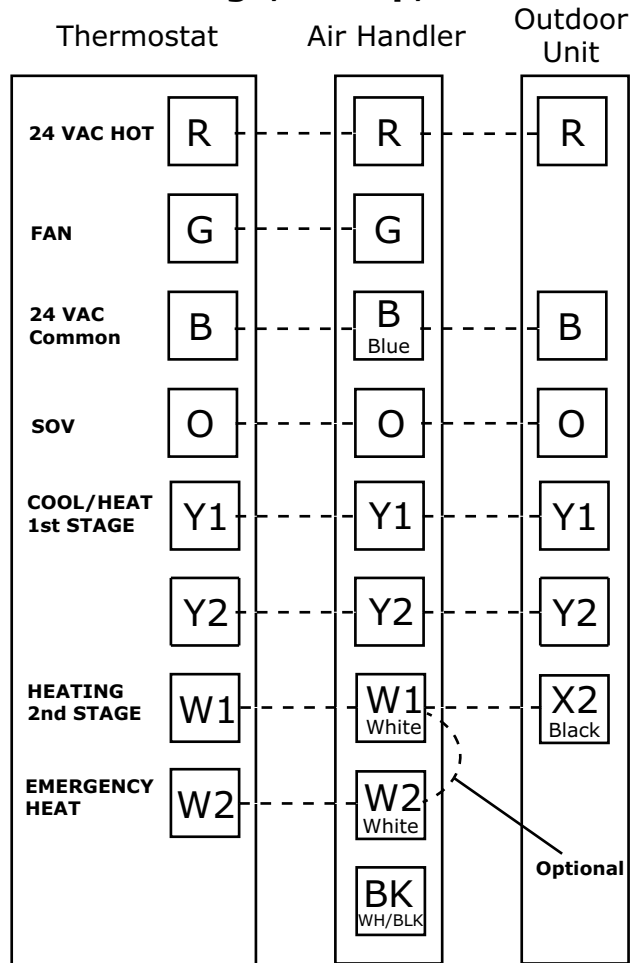

1. * Units with pigtailed require wirenuts for connections.
2. Cap all unused wires.
3. For BK enabled comfort control, do not connect Y1 or Y2 at the air handler
4. For BK enabled comfort control, cut the jumper wire between R and BK on the control board. See wiring schematic for details.
5. In systems for multiple stages of electric heat, jumper W1 and W2 together if comfort control has only one stage of heat.

TEM Convertibility

Figure 1. Multi-Position Air Handler
 * = No Internal Modifications Required.

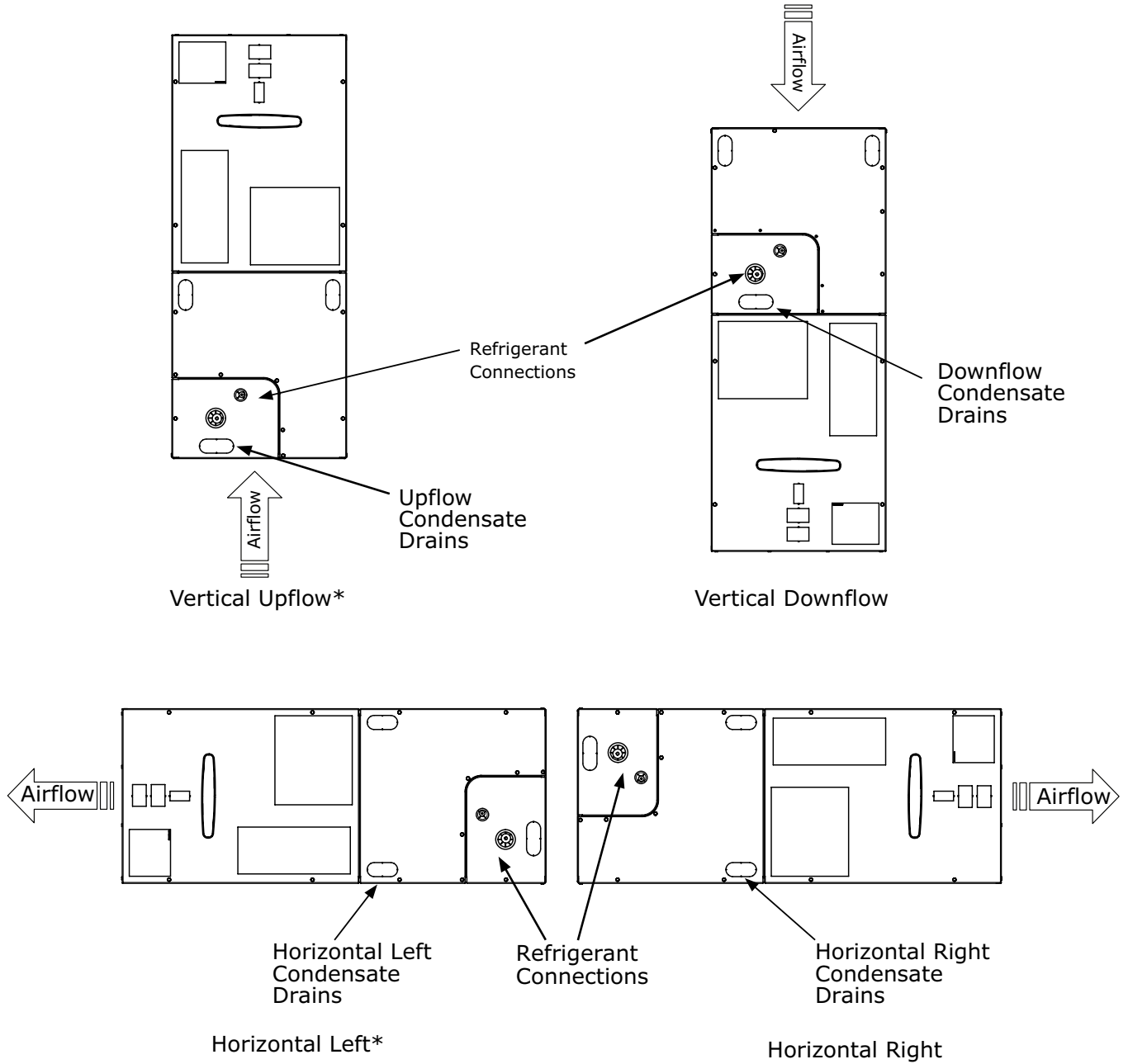



TEM6 Air Handler Dimensional Data

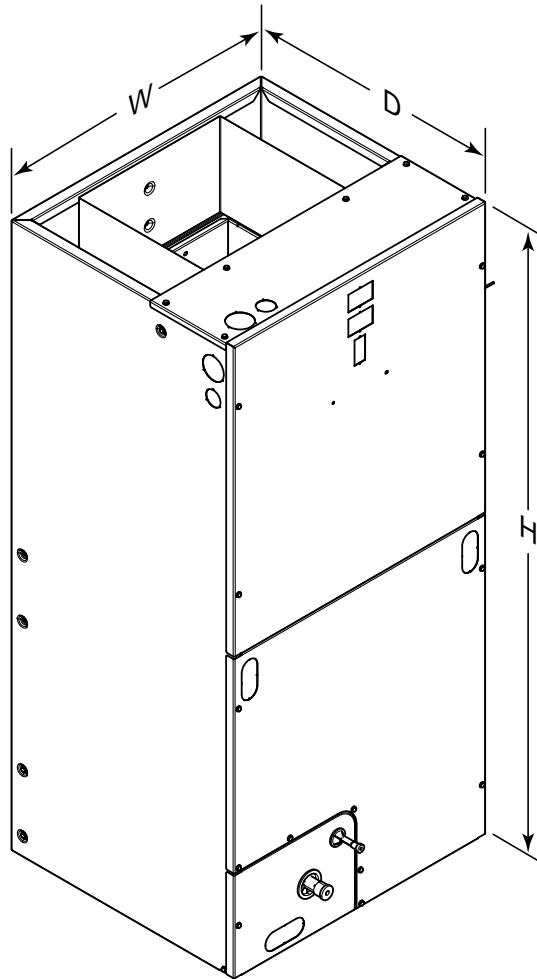

Model No.	H	W	D
TEM6A0B24H21SC	45.02	18.50	21.13
TEM6A0B30H21SC	45.02	18.50	21.13
TEM6A0C36H31SC	51.27	23.50	21.13
TEM6A0C42H41SC	51.27	23.50	21.13
TEM6A0C48H41SC	57.40	23.50	21.13
TEM6B0C60H51SA	57.40	23.50	21.13



Outline Drawing

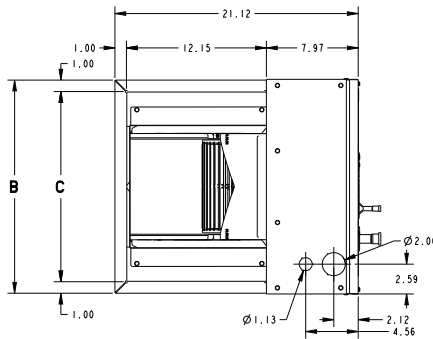

MINIMUM UNIT CLEARANCE TABLE	
	SERVICE CLEARANCE (RECOMMENDED)
SIDES	2"
FRONT	21"
BACK	0"
INLET DUCT	1"
OUTLET DUCT	N/A

NOTE: THIS UNIT IS APPROVED FOR INSTALLATION CLEARANCES TO COMBUSTIBLE MATERIAL AS STATED ON THE UNIT RATING NAMEPLATE

ALL DIMENSIONS ARE REFERENCE DIMENSIONS

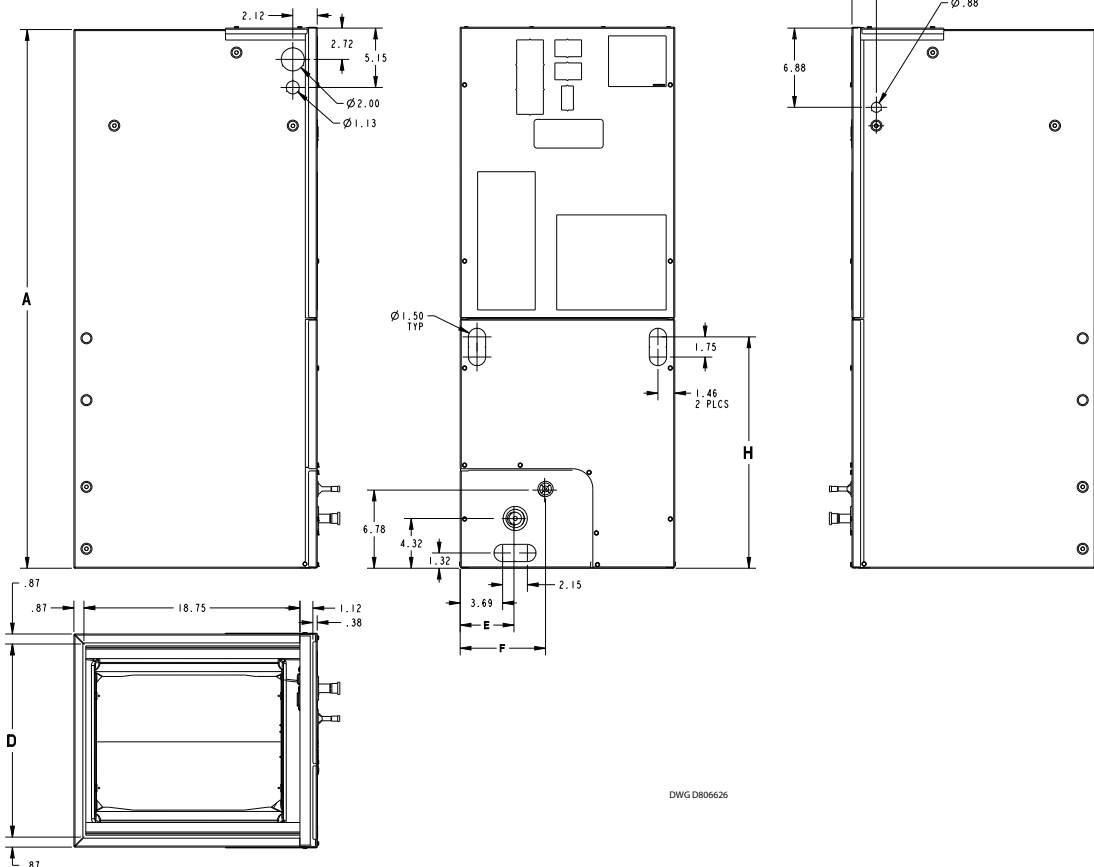

DWG D806626

PRODUCT DIMENSIONS									
Air Handler Model	A	B	C	D	E	F	H	Flow Control	Gas Line Braze
TEM6A0B24, 30	46.77	18.50	16.50	16.75	4.68	7.33	20.09	TXV	3/4
TEM6A0C36, 42	51.27	23.50	21.50	21.75	7.01	9.66	24.59	TXV	7/8
TEM6A0C48/ TEM6B0C60	57.40	23.50	21.50	21.75	4.68	9.66	27.19	TXV	7/8

All dimensions are in inches



Trane - by Trane Technologies (NYSE: TT), a global innovator - creates comfortable, energy efficient indoor environments for commercial and residential applications. For more information, please visit trane.com or tranetechnologies.com.



Trane has a policy of continuous data improvement and it reserves the right to change design and specifications without notice. We are committed to using environmentally conscious print practices.