

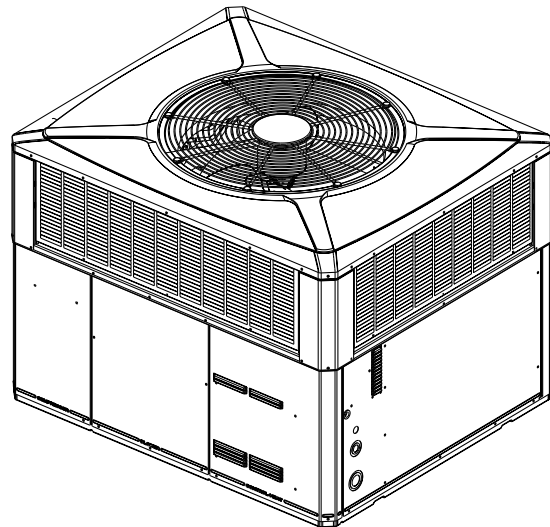

Product Data

Single Packaged Heat Pump 14 SEER Convertible, 2 – 5 Ton

4WCC4024A1000A
4WCC4030A1000A
4WCC4036A1000A
4WCC4042A1000A
4WCC4048A1000A
4WCC4060A1000A



Note: "Graphics in this document are for representation only. Actual model may differ in appearance."



SAFETY SECTION

Important — This document contains a wiring diagram, a parts list, and service information. This is customer property and is to remain with this unit. Please return to service information pack upon completion of work.

⚠ WARNING

HAZARDOUS VOLTAGE!
Failure to follow this Warning could result in property damage, severe personal injury, or death.
Disconnect all electric power, including remote disconnects before servicing. Follow proper lockout/tagout procedures to ensure the power cannot be inadvertently energized.

⚠ WARNING

SAFETY AND ELECTRICAL HAZARD!
Failure to follow this Warning could result in property damage, severe personal injury, or death.
These servicing instructions are for use by qualified personnel only. To reduce the risk of electrical shock, do not perform any servicing other than that contained in these operating instructions unless you are qualified to do so.

⚠ CAUTION

GROUNDING REQUIRED!
Failure to inspect or use proper service tools may result in equipment damage or personal injury.
Reconnect all grounding devices. All parts of this product that are capable of conducting electrical current are grounded. If grounding wires, screws, straps, clips, nuts, or washers used to complete a path to ground are removed for service, they must be returned to their original position and properly fastened.

⚠ WARNING

UNIT CONTAINS R-410A REFRIGERANT!
Failure to use proper service tools may result in equipment damage or personal injury. R-410A operating pressure exceeds the limit of R-22. Proper service equipment is required. Service using only R-410A Refrigerant and approved POE compressor oil.

⚠ WARNING

SAFETY HAZARD!
Operating the unit without the access panels properly installed may result in severe personal injury or death.
Do not operate the unit without the evaporator fan access panel or evaporator coil access panel in place.

⚠ WARNING

WARNING!
This product can expose you to chemicals including lead, which are known to the State of California to cause cancer and birth defects or other reproductive harm. For more information go to www.P65Warnings.ca.gov.

Important: Wear appropriate gloves, arm sleeve protectors and eye protection when servicing or maintaining this equipment.

Important: Air filters and media wheels or plates shall meet the test requirements in UL 900.



Table of Contents

Single Packaged Heat Pump System.....	4
Optional Equipment Listing.....	5
Product Specifications.....	7
Supplementary Electric Heaters	11
Indoor Fan Performance (230v)	12
Wiring Diagrams.....	16
Full Perimeter Roof Mounting Curb.....	22
Optional Equipment — Economizer.....	24
Optional Equipment — Outside Air Damper	25
Optional Equipment — Filter Rack	26
Outline Drawings.....	27
Mechanical Specifications	33



Single Packaged Heat Pump System

Introducing the new Trane Single Heat Pump System

Single Packaged Electric Heat Pumps are easy and versatile to install.

Because cooling and heating functions are all contained in a single cabinet, Trane packaged heat pump systems are easy to install and service. It can be flush mounted beside your home at ground level or placed on the roof for horizontal or downflow installation. When connected to an optional Trane thermostat control, and air distribution ducts, you have a highly efficient, total home comfort system.

Single Packaged Electric Heat Pump Systems are unmatched in quality and reliability.

All major components on these products, including the compressor, have been designed and manufactured for maximum service. Every compressor is designed and manufactured to exacting specifications. Each design is life tested in extreme environments to ensure reliable and long lasting operation in normal applications. Each compressor has internal motor protection for added reliability.

Single Packaged Electric Heat Pump Systems provide better performance.

Our single packaged cooling/heating units offer cooling/heating efficiencies that are unmatched in the industry and provide you with a product far superior in performance than the competition.



Optional Equipment Listing

* = T, W, or Y	
Hinged Filter Access Door (4*CC4024-036) (4*CY4024-4036)	BAYCCDOR1A []
Hinged Filter Access Door (4*CC4042-060) (4*CY4042-4060)	BAYCCDOR2A []
Roof Curb Full Perimeter (4*CC024-036A) (4*CY4024-4036)	BAYCURB050A []
Roof Curb Full Perimeter (4*CC042-060A) (4*CY4042-4060)	BAYCURB051A []
Roof Curb Utility Extension Kit (BAYCURB050A)	BAYUTIL101B []
Roof Curb Utility Extension Kit (BAYCURB051A)	BAYUTIL101B []
0-25% Manual Fresh Air Damper (4*CC4024-36A) (4*CY4024-4036) ^(a)	BAYOSAH001A []
0-25% Manual Fresh Air Damper (4*CC4042-60A) (4*CY4042-4060) ^(a)	BAYOSAH002A []
Motorized Fresh Air Damper (4*CC4024-036A) (4*CY4024-4036) ^(a)	BAYDMPR101A []
Motorized Fresh Air Damper (4*CC4042-060A) (4*CY4042-4060) ^(a)	BAYDMPR102A []
16" Round Duct Adapter (2 per box) (4*CC4024-036A) (4*CY4024-4036) ^(b)	BAYSQRD001A []
18" Round Duct Adapter (2 per box) (4*CC4024-060A) (4*CY4024-4036) ^(b)	BAYSQRD002A []
0-100% Mod Economizer w/Baro. Relief (4*CC4024-036A) (4*CY4024-4036) ^{(a)(c)(d)}	BAYECON101B []
0-100% Mod Economizer w/Baro. Relief (4*CC4042-060A) (4*CY4042-4060) ^{(a)(d)}	BAYECON102B []
0-100% Horizontal Economizer (4*CC4024-36A) (4*CY4024-4036) ^(a)	BAYECON200B []
0-100% Horizontal Economizer (4*CC4042-60A) (4*CY4042-4060) ^(a)	BAYECON201B []
Enthalpy Control for Economizer (ALL-BAYECON)	BAYEENTH001A []
Remote Potentiometer (ALL-BAYECON)	BAYSTAT023 []
1"–2" Filter Frame (4*CC4024-036A) (4*CY4024-4036) (18 x 25 filter not included)	BAYFLTR101C []
1"–2" Filter Frame (4*CC4042-060A) (4*CY4042-4060) (two 18 x 20 filters not included)	BAYFLTR201C []
Head Pressure Control (Low Ambient Cool) (208/240v) Kit	BAYLOAM105A []
Quick Start Kit (4WCC4-A1)(4TCC4-A1)	BAYQSTK300A []
Quick Start Kit (4YCC4-A1)	BAYQSTK301A []
Crankcase Heater Scroll (4*CC4024-036) (4*CY4024-4036) (230v)	BAYCCHT103A []
Crankcase Heater Scroll (4*CC4042-060) (4*CY4042-4060) (230v)	BAYCCHT102A []
Crankcase Heater Scroll (4*CC4024-036) (4*CY4024-4036) (230v)	BAYCCHT301A []
Crankcase Heater Scroll (4*CC4042-060) (4*CY4042-4060) (230v)	BAYCCHT302A []
Adapter Curb (4*CC4024-36A) (4*CY4024-4036A) to BAYCURB030,38	BAYADAP050A []
Adapter Curb (4*CC4024-36A) (4*CY4024-4036A) to BAYCURB033	BAYADAP051A []
Adapter Curb (4*CC4042-60A) (4*CY4042-4060A) to BAYCURB030,38	BAYADAP052A []
Adapter Curb (4*CC4042-60A) (4*CY4042-4060A) to BAYCURB033	BAYADAP053A []
Adapter Curb (4*CC4042-60A) (4*CY4042-4060A) to BAYCURB034	BAYADAP054A []
12" Duct Shroud Covers Horizontal (4*CC4024-060A) (4*CY4024-4060A)	BAYCOVR112A []
18" Duct Shroud Covers Horizontal (4*CC4024-060A) (4*CY4042-4060A)	BAYCOVR118A []
Extreme Condition Mounting Kit — All BAYCURB & BAYADAP	BAYEXMK001A []
Extreme Condition Mounting Kit — All BAYUTIL	BAYEXMK002B []
Extreme Condition Mounting Kit — All Slab Mounts	BAYEXMK003B []
Lifting Lug Kit	BAYLIFT002B []
LP Conversion Kit (All 115K Models)	BAYLPKT100A []
LP Conversion Kit (All 60K and 90K Models)	BAYLPKT101A []
LP Conversion Kit (All 70K Models)	BAYLPKT102A []
SUPPLEMENTARY HEATERS (1 PHASE) * = T or W Only (Does not apply to Gas/Electric dual fuel models)	
3.76/5.0 KW Heater (208/240V 1 PH) (4*CC4024-060A1)	BAYHTRV105F []
6.0/8.0 KW Heater (208/240V 1 PH) (4*CC4024-060A1)	BAYHTRV108F []
7.50/10.0 KW Heater (208/240V 1 PH) (4*CC4024-060A1)	BAYHTRV110F []
11.27/15.0 KW Heater (208/240V 1 PH) (4*CC4030-060A1)	BAYHTRV115F []
15.0/20.0 KW Heater (208/240V 1 PH) (4*CC4048-060A1)	BAYHTRV120F []
18.78/25.0 KW Heater (208/240V 1 PH) (4*CC40060A1)	BAYHTRV125F []



Optional Equipment Listing

SUPPLEMENTARY HEATERS (3 PHASE) * = T or W Only (Does not apply to Gas/Electric dual fuel models)	
3.76/5.0 KW Heater (208/240V 3 PH) (4WCY4036-060A3)	BAYHTRV305F []
3.76/5.0 KW Heater (208/240V 3 PH) (4WCY4036-060A3)	BAYHTRV308F []
7.50/10.0 KW Heater (208/240V 3 PH) (4WCY4024-048A3)	BAYHTRV310F []
11.27/15.0 KW Heater (208/240V 3 PH) (4WCY4036-060A3)	BAYHTRV315F []
15.0/20.0 KW Heater (208/240V 3 PH) (4WCY4048-060A3)	BAYHTRV320F []
18.78/25.0 KW Heater (208/240V 3 PH) (4WCY4048-060A1)	BAYHTRV325F []
Single Power Entry Kit (e)	BAYSPEK060F []
Single Power Entry Kit (e)	BAYSPEK061E []
Single Power Entry Kit (e)	BAYSPEK062F []
Single Power Entry Kit (e)	BAYSPEK063F []
Single Power Entry Kit (e)	BAYSPEK064E []
Single Power Entry Kit (e)	BAYSPEK065E []

- (a) Must use internal filter frame when economizer or fresh air kit is used.
- (b) It is the responsibility of the installing dealer to properly size the ductwork for each specific application.
- (c) Dry bulb control standard with economizer.
- (d) Downflow only.
- (e) Must be selected per unit and heater model



Product Specifications

MODEL	4WCC4024A1000A	4WCC4030A1000A	4WCC4036A1000A
RATED Volts/PH/Hz	208-230/1/60	208-230/1/60	208-230/1/60
Performance Cooling BTUH ^(a)	24600	30400	35800
Indoor Airflow (CFM)	758	985	1114
Power Input (KW)	1.9	2.41	2.8
EER/SEER (BTUH/Watt-Hr.) ^(b)	12.00 / 14.00	12.00 / 14.00	12.00 / 14.00
Sound Power Rating [dB(A)] ^(c)	66.4	70.0	69.4
PERFORMANCE HEATING			
(High Temp.) BTUH	22000	27200	32600
Power Input (KW)	1.8	2.1	2.7
(Low Temp.) BTUH	14300	16,700	21,800
Power Input (KW)	1.12	1.25	1.75
HSPF (BTUH/Watt-Hr)	8.0	8.0	8.0
POWER CONN. — V/Ph/Hz	208-230/1/60	208-230/1/60	208-230/1/60
Min. Brch. Cir. Ampacity ^(d)	19.4	22.6	24.4
Fuse Size — Max. (amps)	30	35	40
Fuse Size — Recmd. (amps)	30	35	40
COMPRESSOR			
	SCROLL	SCROLL	SCROLL
VOLTS/PH/HZ	208-230/1/60	208-230/1/60	208-230/1/60
R.L. Amps — L.R. Amps	12.8 / 58.3	14.1 / 68.2	15.4 / 77.0
OUTDOOR COIL — TYPE			
	SPINE FIN	SPINE FIN	SPINE FIN
Rows/F.P.I	2 / 24	2 / 24	2 / 24
Face Area (sq. ft.)	13.32	13.32	15.49
Tube Size (in.)	3/8	3/8	3/8
Refrigerant Control	EXPANSION VALVE	EXPANSION VALVE	EXPANSION VALVE
INDOOR COIL — TYPE			
	PLATE FIN	PLATE FIN	PLATE FIN
Rows/F.P.I	3 / 15	4/ 15	4 / 15
Face Area (sq. ft.)	3.5	3.5	3.5
Tube Size (in.)	3/8	3/8	3/8
Refrigeration Control	EXPANSION VALVE	EXPANSION VALVE	EXPANSION VALVE
Drain Conn. Size (in.)	3/4 FEMALE NPT	3/4 FEMALE NPT	3/4 FEMALE NPT
OUTDOOR FAN — TYPE			
	SWEPT	SWEPT	SWEPT
DIA. (IN.)	23.4	23.4	23.4
DRIVE/NO. SPEEDS	DIRECT / 3	DIRECT / 3	DIRECT / 3
CFM @ 0.0 in. w.g. ^(e)	2550	3270	3250
Motor — HP/R.P.M	1/12 / 850	1/6/ 842	1 / 5 / 855
Volts/Ph/Hz	208-230/1/60	208-230/1/60	208-230 / 1 / 60
F.L. Amps/L.R Amps	.54 / .82	.85 / 1.65	1.1 / 2.0
INDOOR FAN — TYPE			
	CONSTANT TORQUE ECM	CONSTANT TORQUE ECM	CONSTANT TORQUE ECM
Dia. x Width (in.)	10.62 X 10.68	10.62 X 10.68	10.62 X 10.68
Drive/No. Speeds	DIRECT / 3	DIRECT / 3	DIRECT / 3
CFM @ 0.0 in. w.g. ^(f)	SEE FAN PERF TABLE	SEE FAN PERF TABLE	SEE FAN PERF TABLE
Motor — HP/R.P.M.	1/3 / 1050	1/2 / 1050	1/2 / 1050
Volts/Ph/Hz	208-230/1/60	208-230/1/60	208-230/1/60



Product Specifications

F.L. Amps	2.8	4	4.1
FILTER / FURNISHED	NO	NO	NO
Type Recommended	THROWAWAY	THROWAWAY	THROWAWAY
Recmd. Face Area (sq. ft.) ^(g)	2.7	4.0	4.0
REFRIGERANT	R-410	R-410	R-410
Charge (lbs.)	5.74	7.2	7.2
CHARGING SPECIFICATIONS			
Subcooling	16°	14°	11°
DIMENSIONS	H X D X W	H X D X W	H X D X W
Crated (in.)	46 X 45 X 52	48 X 45 X 52	48 X 45 X 52
WEIGHT			
Shipping (lbs.) / Net (lbs.)	402 / 328	430 / 355	439 / 364

(a) Rated in accordance with AHRI Standard 210/240.

(b) Rated in accordance with D.O.E. test procedure.

(c) Sound Power values are not adjusted for AHRI 270-95 tonal corrections.

(d) Calculated in accordance with currently prevailing Nat'l Electrical Code.

(e) Standard Air — Dry Coil — Outdoor.

(f) Standard Air — Dry Coil — Indoor

(g) Filters must be installed in return air stream. Square footages listed are based on 300 f.p.m. face velocity. If permanent filters are used size per manufacturer's recommendation with a clean resistance of 0.05" W.C.

Product Specifications

MODEL	4WCC4042A1000A	4WCC4048A1000A	4WCC4060A1000A
RATED Volts/PH/Hz	208-230/1/60	208-230/1/60	208-230/1/60
Performance Cooling BTUH ^(a)	43000	48000	58000
Indoor Airflow (CFM)	1367	1423	1787
Power Input (KW)	3.5	3.9	4.6
EER/SEER (BTU/Watt-Hr.) ^(b)	12.00 / 14.00	12.00 / 14.00	12.00 / 14.00
Sound Power Rating [dB(A)] ^(c)	71.5	72.5	77.3
PERFORMANCE HEATING			
(High Temp.) BTUH	37,600	43500	54000
Power Input (KW)	3.45	3.7	4.6
(Low Temp.) BTUH	22800	25400	34600
Power Input (KW)	1.94	2.10	2.80
HSPF (BTUH/Watt-Hr)	8.0	8.0	8.0
POWER CONN. — V/Ph/Hz	208-230/1/60	208-230/1/60	208-230/1/60
Min. Brch. Cir. Ampacity ^(d)	28.3	31.9	39.0
Fuse Size — Max. (amps)	45	50	60
Fuse Size — Recmd. (amps)	45	50	60
COMPRESSOR	SCROLL	SCROLL	SCROLL
VOLTS/PH/Hz	208-230/1/60	208-230/1/60	208-230/1/60
R.L. Amps — L.R. Amps	16.7 / 123.9	19.6 / 130.0	24.4 / 144.2
OUTDOOR COIL — TYPE	SPINE FIN	SPINE FIN	SPINE FIN
Rows/F.P.I	2 / 24	2 / 24	2 / 24
Face Area (sq. ft.)	20.54	20.54	22.99
Tube Size (in.)	3/8	3/8	3/8
Refrigerant Control	EXPANSION VALVE	EXPANSION VALVE	EXPANSION VALVE
INDOOR COIL — TYPE	PLATE FIN	PLATE FIN	PLATE FIN
Rows/F.P.I	3 / 15	3 / 15	4 / 15
Face Area (sq. ft.)	5.0	5.0	5.0
Tube Size (in.)	3/8	3/8	3/8
Refrigeration Control	EXPANSION VALVE	EXPANSION VALVE	EXPANSION VALVE
Drain Conn. Size (in.)	3/4 FEMALE NPT	3/4 FEMALE NPT	3/4 FEMALE NPT
OUTDOOR FAN — TYPE	SWEPT	SWEPT	SWEPT
DIA. (IN.)	28.3	28.3	28.3
DRIVE/NO. SPEEDS	DIRECT / 3	DIRECT / 3	DIRECT / 3
CFM @ 0.0 in. w.g. ^(e)	4400	4400	5500
Motor — HP/R.P.M	1/4 / 798	1 / 4 / 825	1/3 / 825
Volts/Ph/Hz	208-230 / 1 / 60	208-230/1/60	208-230/1/60
F.L. Amps/L.R Amps	1.51 / 3.07	1.51 / 3.07	1.7 / 3.5
INDOOR FAN — TYPE	CONSTANT TORQUE ECM	CONSTANT TORQUE ECM	CONSTANT TORQUE ECM
Dia. x Width (in.)	10.62 X 10.62	10.62 X 10.62	11.87 X 10.68
Drive/No. Speeds	DIRECT / 3	DIRECT / 3	DIRECT / 3
CFM @ 0.0 in. w.g. ^(f)	SEE FAN PERF TABLE	SEE FAN PERF TABLE	SEE FAN PERF TABLE
Motor — HP/R.P.M.	3/4 / 1050	3/4 / 1050	1 / 1050
Volts/Ph/Hz	208-230/1/60	208-230/1/60	208-230/1/60
F.L. Amps	6	6	6.9
FILTER / FURNISHED	NO	NO	NO
Type Recommended	THROWAWAY	THROWAWAY	THROWAWAY



Product Specifications

Recmd. Face Area (sq. ft) ^(g)	5.3	5.3	5.3
REFRIGERANT	R-410	R-410	R-410
Charge (lbs.)	8.33	8.38	11.0
CHARGING SPECIFICATIONS			
Subcooling	9°	8°	6°
DIMENSIONS	H X D X W	H X D X W	H X D X W
Crated (in.)	48 X 45 X 52	50 X 47 X 62	52 X 47 X 62
WEIGHT			
Shipping (lbs.) / Net (lbs.)	548 / 444	529 / 425	594 / 490

- (a) Rated in accordance with AHRI Standard 210/240.
- (b) Rated in accordance with D.O.E. test procedure.
- (c) Sound Power values are not adjusted for AHRI 270–95 tonal corrections.
- (d) Calculated in accordance with currently prevailing Nat'l Electrical Code.
- (e) Standard Air — Dry Coil — Outdoor.
- (f) Standard Air — Dry Coil — Indoor
- (g) Filters must be installed in return air stream. Square footages listed are based on 300 f.p.m. face velocity. If permanent filters are used size per manufacturer's recommendation with a clean resistance of 0.05" W.C.



Supplementary Electric Heaters

UNIT MODEL	ELECTRIC HEATER MODEL	RATED VOLT-AGE	PHASE	AMPS	HEATER CAPACITY		NO. OF STAGES	KW/STAGE		MCA	MAX. FUSE OR HACR CKT BKR SIZE ^(a)	CANADA ONLY MAX. CKT BKR SIZE ^(b)
					KW	BTUH		1	2			
W/TC*3018-060#1 W/TCY*024-060#1 WCZ6024-060#1 *CC4018-060#1	BAYHTRV105	208/ 240	1	18/ 21	3.76/ 5.0	12800/ 17100	1	3.76/ 5.0	—	23/ 26	25/30	25/30
W/TC*3018-060#1 W/TCY*024-060#1 WCZ6024-060#1 *CC4018-060#1	BAYHTRV108	208/ 240	1	29/ 33	6.0/ 8.0	20500/ 27300	1	6.0/ 8.0	—	36/ 41	40/45	40/45
W/TC*3024-060#1 W/TCY*024-060#1 WCZ6024-060#1 *CC4024-060#1	BAYHTRV110	208/ 240	1	36/ 42	7.5/ 10.0	25600/ 34100	1	7.5/ 10.0	—	45/ 52	45/60	45/60
W/TC*3030-060#1 W/TCY*030-060#1 WCZ6036-060#1 *CC4030-060#1	BAYHTRV115	208/ 240	1	54/ 63	11.27/ 15.0	38500/ 51200	2	7.5/ 10.0	3.76/ 5.0	68/ 78	70/80	70/80
W/TC*3042-060#1 W/TCY*042-060#1 WCZ6048-060#1 *CC4042-060#1	BAYHTRV120#	208/ 240	1	72/ 83	15.0/ 20.0	51200/ 68300	2	7.5/ 10.0	7.5/ 10.0	90/ 104	90/110	90/110
WC*3042#1 W/TC3060#1 W/TCY*042-060#1 WCZ6048-060#1 *CC4060#1	BAYHTRV125#	208/ 240	1	90/ 104	18.78/ 25.0	51200/ 68300	2	11.26/ 15.0	7.5/ 10.0	113/ 130	125/150	125/150
W/TC*3036-060#3 W/TCY4036-060#3 WCZ6036-060#3 *CC4036-060#3	BAYHTRV305	208/ 240	3	10/ 12	3.76/ 5.0	64100/ 85300	1	3.76/ 5.0	—	13/ 15	15/15	15/15
W/TC*3036-060#3 W/TCY4036-060#3 WCZ6036-060#3 *CC4036-060#3	BAYHTRV308	208/ 240	3	17/ 19	6.0/ 8.0	20500/ 27300	1	6.0/ 8.0	—	21/ 24	25/25	25/25
W/TC*3036-060#3 W/TCY4036-060#3 WCZ6036-060#3 *CC4036-060#3	BAYHTRV310	208/ 240	3	21/ 24	7.5/ 10.0	25600/ 34100	1	7.5/ 10.0	—	26/ 30	30/30	30/30
W/TC*3036-060#3 W/TCY4036-060#3 WCZ6036-060#3 *CC4036-060#3	BAYHTRV315	208/ 240	3	31/ 36	11.27/ 15.0	38500/ 51200	2	7.5/ 10.0	3.76/ 5.0	39/ 45	40/45	40/45
W/TC*3048-060#3 W/TCY4048-060#3 WCZ6048-060#3 *CC4048-060#3	BAYHTRV320	208/ 240	3	42/ 48	15.0/ 20.0	51200/ 68300	2	7.5/ 10.0	7.5/ 10.0	52/ 60	60/60	60/60
W/TC*3060#3 W/TCY4048-060#3 WCZ6048-060#3 *CC4060#3	BAYHTRV325#	208/ 240	3	52/ 60	18.78/ 25.0	64100/ 85300	2	11.26/ 15.0	7.5/ 10.0	65/ 75	70/80	70/80
W/TC*3036-060#4 WCZ6036-060#4 *CC4036-60#4	BAYHTRV405	480	3	6	5.0	17100	1	5.0	—	8	15	15
W/TC*3036-060#4 WCZ6036-060#4 *CC4036-60#4	BAYHTRV408	480	3	10	8.0	27300	1	8.0	—	13	15	15
W/TC*3036-060#4 WCZ6036-060#4 *CC4036-60#4	BAYHTRV410	480	3	12	10.0	34100	1	10.0	—	15	15	15
W/TC*3036-060#4 WCZ6036-060#4 *CC4036-60#4	BAYHTRV415	480	3	18	15.0	51200	2	10.0	5.0	23	25	25
W/TC*3048-060#4 WCZ6048-060#4 *CC4048-60#4	BAYHTRV420	480	3	24	20.0	68300	2	10.0	10.0	30	30	30



Supplementary Electric Heaters

W/TC*3060#4 WCZ6048-060#4 *CC4048-60#4	BAYHTRV425	480	3	30	25.0	85300	2	15.0	10.0	38	40	40
--	------------	-----	---	----	------	-------	---	------	------	----	----	----

1. Any power supply and circuits must be wired and protected in accordance with local electrical codes.
2. The values listed in the above table are for the electric heater only.
3. Field wiring must be rated at least 75° C.
4. * indicates an alpha character
5. † indicates model letter
6. # Heater uses fuses

ALL VALUES ARE FOR THE ELECTRIC HEATER ONLY

- (a) The HACR circuit breaker is for U.S.A. installations only.
 (b) For Canada installation reference only.

Indoor Fan Performance (230v)

Table 1. Horizontal Airflow

4WCC4024A1		EXTERNAL STATIC PRESSURE (IN. WG)										
MOTOR SPEED		0.0	0.1	0.2	0.3	0.4	0.5	0.6	0.7	0.8	0.9	1.0
LOW	WATTS	63	70	77	83	90	95	-	-	-	-	-
	CFM	899	820	755	681	581	505	-	-	-	-	-
MEDIUM	WATTS	75	83	91	97	104	111	-	-	-	-	-
	CFM	959	886	818	756	673	589	-	-	-	-	-
HIGH	WATTS	-	-	119	127	134	142	149	155	-	-	-
	CFM	-	-	940	886	820	748	670	605	-	-	-

Table 2. Down Airflow

4WCC4024A1		EXTERNAL STATIC PRESSURE (IN. WG)										
MOTOR SPEED		0.0	0.1	0.2	0.3	0.4	0.5	0.6	0.7	0.8	0.9	1.0
COOLING — LOW	WATTS	63	71	77	83	90	95	-	-	-	-	-
	CFM	890	811	747	674	575	500	-	-	-	-	-
COOLING — MED	WATTS	76	84	91	98	105	112	-	-	-	-	-
	CFM	950	877	810	749	666	583	-	-	-	-	-
COOLING — HIGH	WATTS	-	-	119	127	135	143	150	156	-	-	-
	CFM	-	-	931	877	812	741	663	599	-	-	-

Table 3. Horizontal Airflow

4WCC4030A1		EXTERNAL STATIC PRESSURE (IN. WG)										
MOTOR SPEED		0.0	0.1	0.2	0.3	0.4	0.5	0.6	0.7	0.8	0.9	1.0
LOW	WATTS	119	128	136	145	155	-	-	-	-	-	-
	CFM	1065	1012	951	894	829	-	-	-	-	-	-
MEDIUM	WATTS	149	157	167	175	186	196	205	-	-	-	-
	CFM	1150	1102	1046	993	938	877	828	-	-	-	-
HIGH	WATTS	-	-	221	230	240	252	263	273	-	-	-
	CFM	-	-	1184	1136	1085	1032	978	934	-	-	-

Table 4. Down Airflow

4WCC4030A1		EXTERNAL STATIC PRESSURE (IN. WG)										
MOTOR SPEED		0.0	0.1	0.2	0.3	0.4	0.5	0.6	0.7	0.8	0.9	1.0
COOLING — LOW	WATTS	120	128	137	145	155	-	-	-	-	-	-
	CFM	1054	1002	942	885	821	-	-	-	-	-	-
COOLING — MED	WATTS	149	158	167	176	186	197	206	-	-	-	-
	CFM	1138	1091	1035	983	928	868	820	-	-	-	-
COOLING — HIGH	WATTS	-	-	222	231	242	253	264	274	-	-	-
	CFM	-	-	1173	1124	1074	1022	969	925	-	-	-

Table 5. Horizontal Airflow

4WCC4036A1		EXTERNAL STATIC PRESSURE (IN. WG)										
MOTOR SPEED		0.0	0.1	0.2	0.3	0.4	0.5	0.6	0.7	0.8	0.9	1.0
LOW	WATTS	145	152	159	167	175	-	-	-	-	-	-
	CFM	1145	1098	1047	982	926	-	-	-	-	-	-
MEDIUM	WATTS	195	202	210	218	227	236	-	-	-	-	-
	CFM	1268	1226	1177	1125	1072	1019	-	-	-	-	-
HIGH	WATTS	-	-	323	331	342	351	361	372	-	-	-
	CFM	-	-	1400	1359	1308	1261	1216	1172	-	-	-

Table 6. Down Airflow

4WCC4036A1		EXTERNAL STATIC PRESSURE (IN. WG)										
MOTOR SPEED		0.0	0.1	0.2	0.3	0.4	0.5	0.6	0.7	0.8	0.9	1.0
COOLING — LOW	WATTS	146	153	159	168	176	-	-	-	-	-	-
	CFM	1133	1087	1037	972	916	-	-	-	-	-	-
COOLING — MED	WATTS	196	203	211	220	228	237	-	-	-	-	-
	CFM	1255	1213	1166	1114	1062	1009	-	-	-	-	-
COOLING — HIGH	WATTS	-	-	324	333	343	353	363	373	-	-	-
	CFM	-	-	1386	1346	1295	1248	1204	1160	-	-	-

Table 7. Horizontal Airflow

4WCC4042A1		EXTERNAL STATIC PRESSURE (IN. WG)										
MOTOR SPEED		0.0	0.1	0.2	0.3	0.4	0.5	0.6	0.7	0.8	0.9	1.0
LOW	WATTS	257	263	272	282	292	302	311	322	-	-	-
	CFM	1411	1355	1295	1239	1189	1145	1104	1060	-	-	-
MEDIUM	WATTS	370	377	386	398	410	421	431	438	-	-	-
	CFM	1615	1550	1495	1445	1397	1351	1312	1285	-	-	-
HIGH	WATTS	-	510	522	531	540	552	565	575	-	-	-
	CFM	-	1732	1683	1628	1576	1533	1496	1458	-	-	-



Supplementary Electric Heaters

Table 8. Down Airflow

4WCC4042A1		EXTERNAL STATIC PRESSURE (IN. WG)										
MOTOR SPEED		0.0	0.1	0.2	0.3	0.4	0.5	0.6	0.7	0.8	0.9	1.0
COOLING — LOW	WATTS	262	268	277	288	298	308	318	328	-	-	-
	CFM	1397	1342	1282	1226	1177	1134	1093	1049	-	-	-
COOLING — MED	WATTS	378	384	394	406	418	430	439	447	-	-	-
	CFM	1599	1535	1480	1430	1383	1338	1299	1272	-	-	-
COOLING — HIGH	WATTS	-	520	533	541	551	563	576	586			
	CFM	-	1715	1666	1612	1560	1518	1481	1443	-	-	-

Table 9. Horizontal Airflow

4WCC4048A1		EXTERNAL STATIC PRESSURE (IN. WG)										
MOTOR SPEED		0.0	0.1	0.2	0.3	0.4	0.5	0.6	0.7	0.8	0.9	1.0
LOW	WATTS	359	371	383	404	406	418	429	440	452	-	-
	CFM	1649	1616	1581	1516	1509	1475	1441	1408	1374	-	-
MEDIUM	WATTS	515	525	536	559	562	575	588	600	612	-	-
	CFM	1871	1827	1789	1731	1724	1693	1661	1630	1600	-	-
HIGH	WATTS	553	566	577	590	601	613	631	643	647	-	-
	CFM	1945	1910	1876	1839	1806	1769	1728	1688	1652	-	-

Table 10. Down Airflow

4WCC4048A1		EXTERNAL STATIC PRESSURE (IN. WG)										
MOTOR SPEED		0.0	0.1	0.2	0.3	0.4	0.5	0.6	0.7	0.8	0.9	1.0
COOLING — LOW	WATTS	367	378	390	412	414	426	438	449	461	-	-
	CFM	1632	1600	1565	1501	1494	1460	1427	1394	1360	-	-
COOLING — MED	WATTS	526	536	547	570	573	586	600	612	625	-	-
	CFM	1853	1808	1771	1713	1707	1676	1645	1614	1584	-	-
COOLING — HIGH	WATTS	564	577	589	602	613	625	644	656	660	-	-
	CFM	1925	1890	1857	1821	1788	1751	1711	1671	1635	-	-

Table 11. Horizontal Airflow

4WCC4060A1		EXTERNAL STATIC PRESSURE (IN. WG)										
MOTOR SPEED		0.0	0.1	0.2	0.3	0.4	0.5	0.6	0.7	0.8	0.9	1.0
LOW	WATTS	515	523	533	544	554	569	582	595	608	621	-
	CFM	1857	1831	1800	1766	1737	1692	1655	1617	1578	1538	-
MEDIUM	WATTS	749	759	769	779	788	803	816	830	845	860	874
	CFM	2083	2058	2032	2003	1974	1943	1911	1877	1843	1807	1771
HIGH	WATTS		910	921	932	941	956	969	983	997	1010	1021
	CFM		2177	2152	2127	2105	2071	2041	2009	1975	1940	1903

Table 12. Down Airflow

4WCC4060A1		EXTERNAL STATIC PRESSURE (IN. WG)										
MOTOR SPEED		0.0	0.1	0.2	0.3	0.4	0.5	0.6	0.7	0.8	0.9	1.0
COOLING — LOW	WATTS	511	521	533	546	558	570	579	593	606	619	
	CFM	1875	1841	1805	1766	1730	1696	1668	1628	1568	1527	
COOLING — MED	WATTS	745	758	771	786	801	815	829	839	849	858	872
	CFM	2104	2063	2034	1999	1965	1931	1894	1869	1846	1795	1759
COOLING — HIGH	WATTS		908	919	930	942	960	971	988	997	1001	1018
	CFM		2184	2150	2104	2073	2027	1998	1961	1937	1905	1890

Wiring Diagrams

Figure 1. 4WCC4024 — 4042 Models

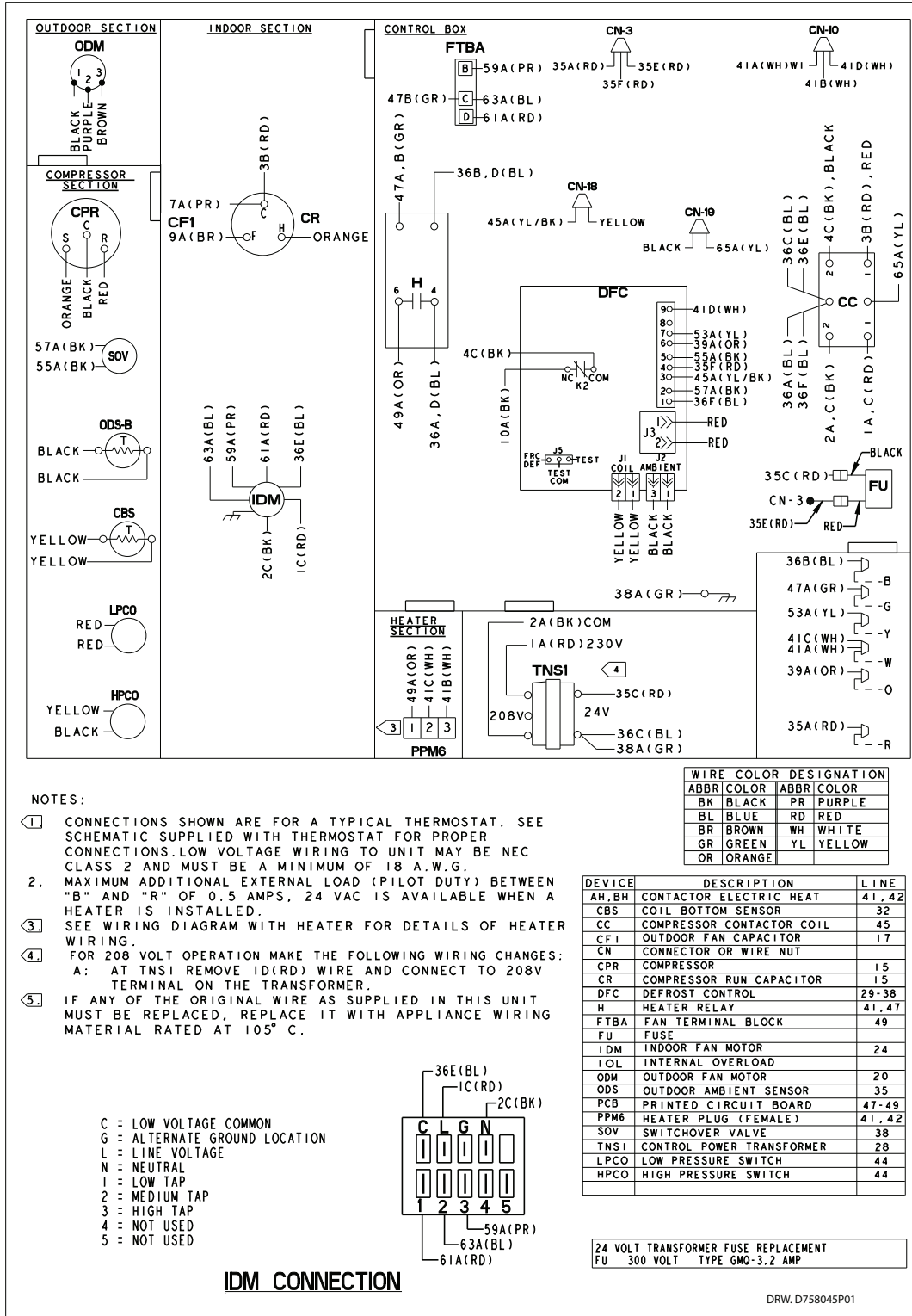

Figure 2. 4WCC4024 — 4042 Models Pg 2

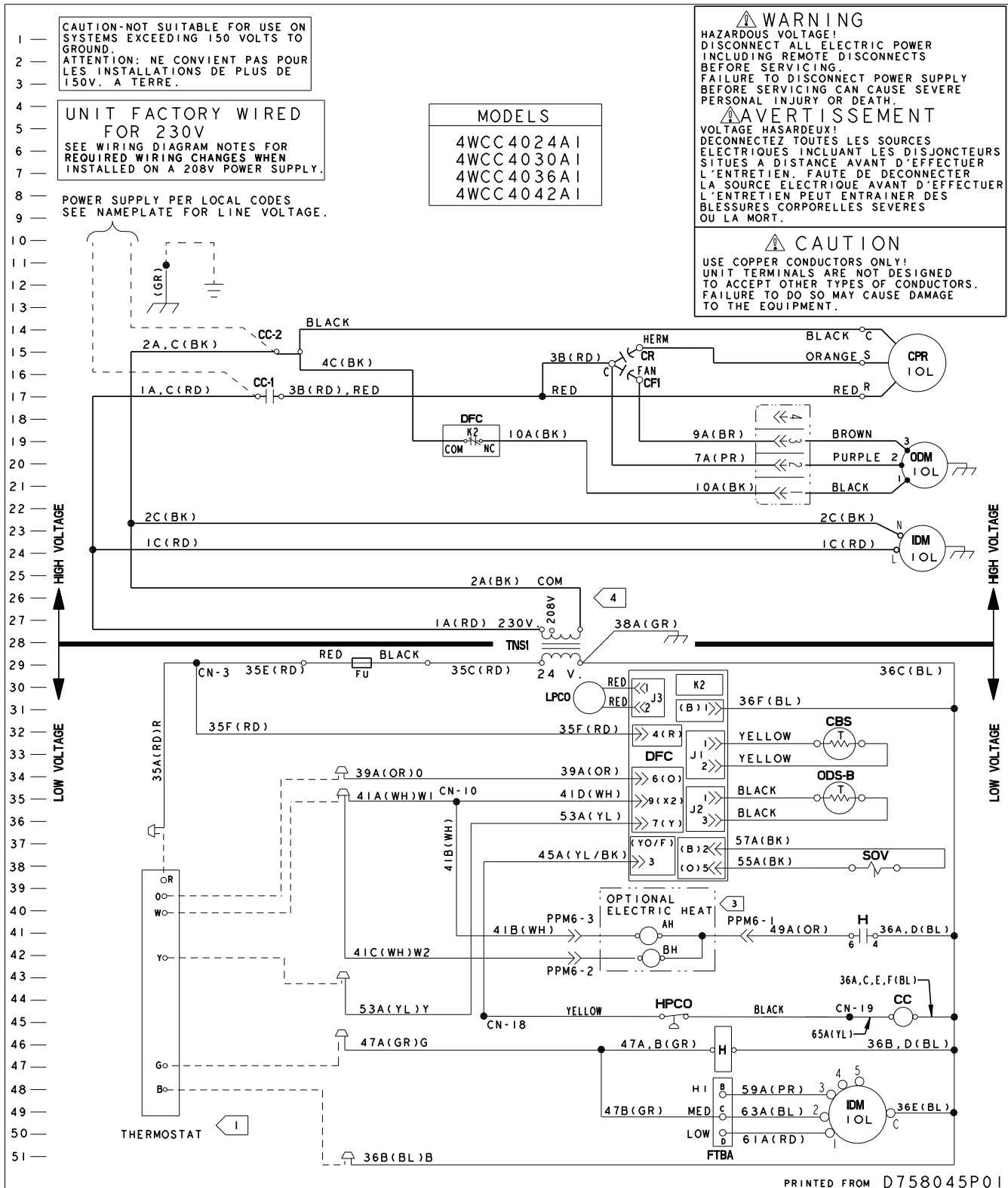
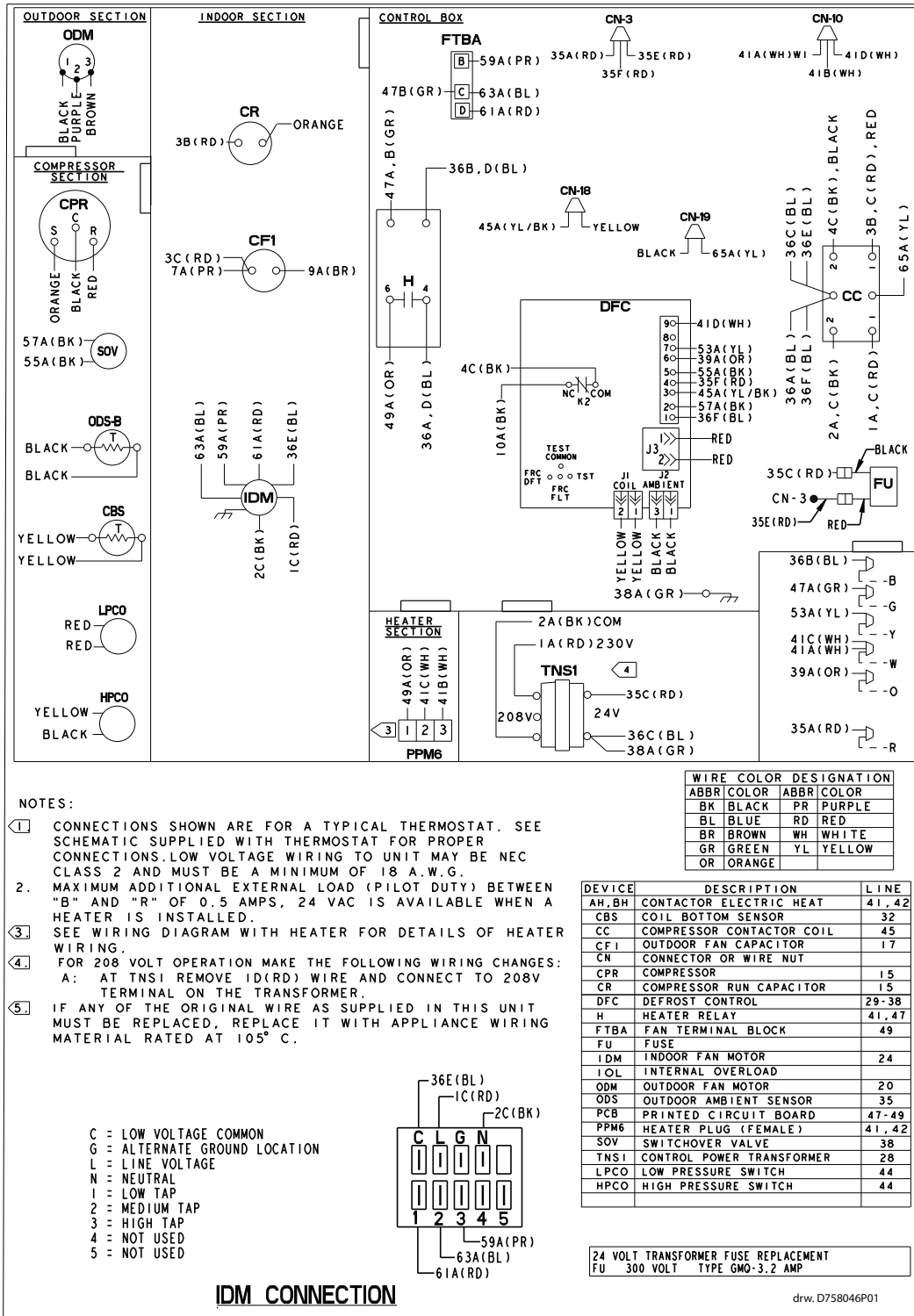

Figure 3. 4WCC4048 Models



drw. D758046P01

Figure 4. 4WCC4048 Models Pg 2

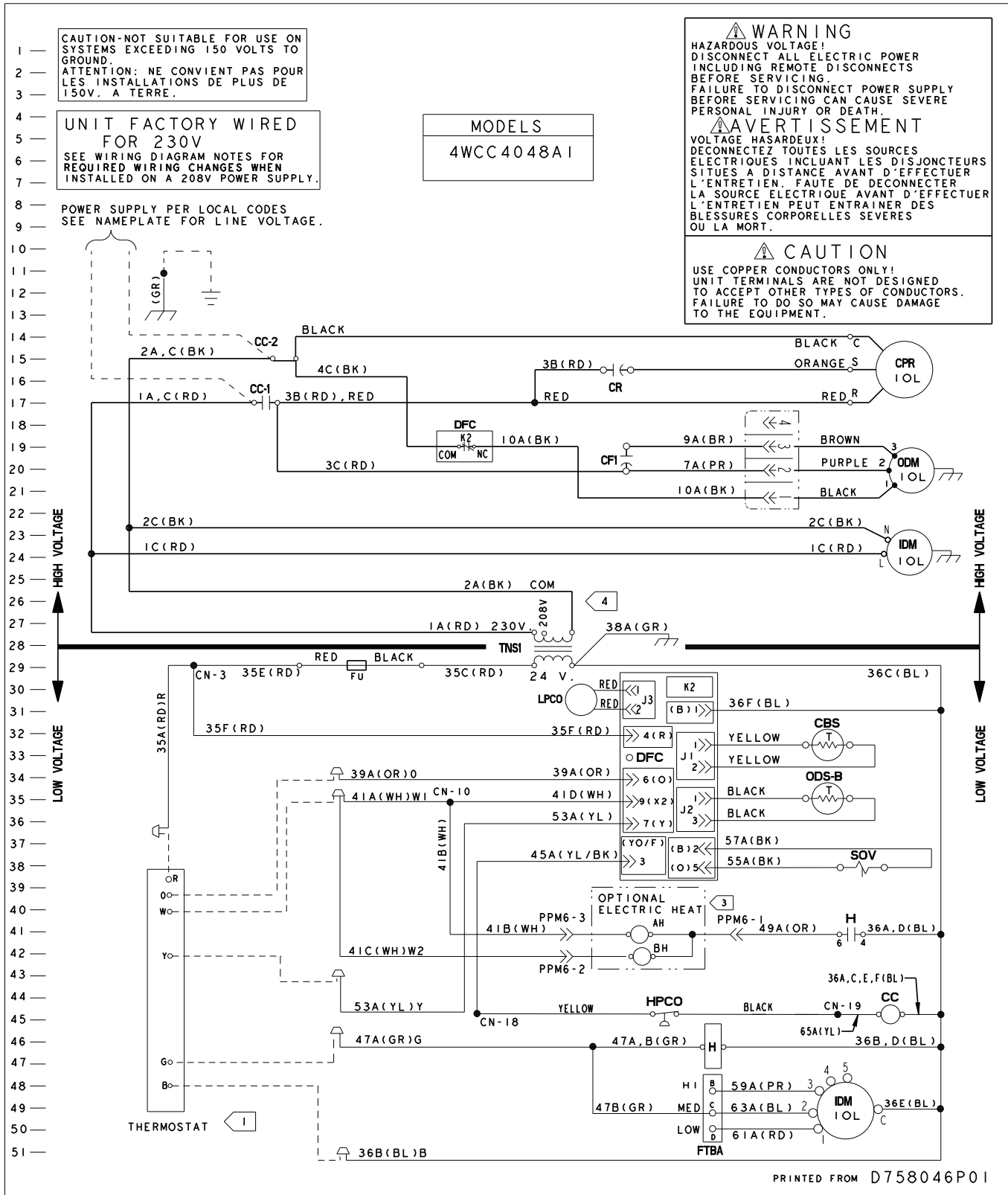
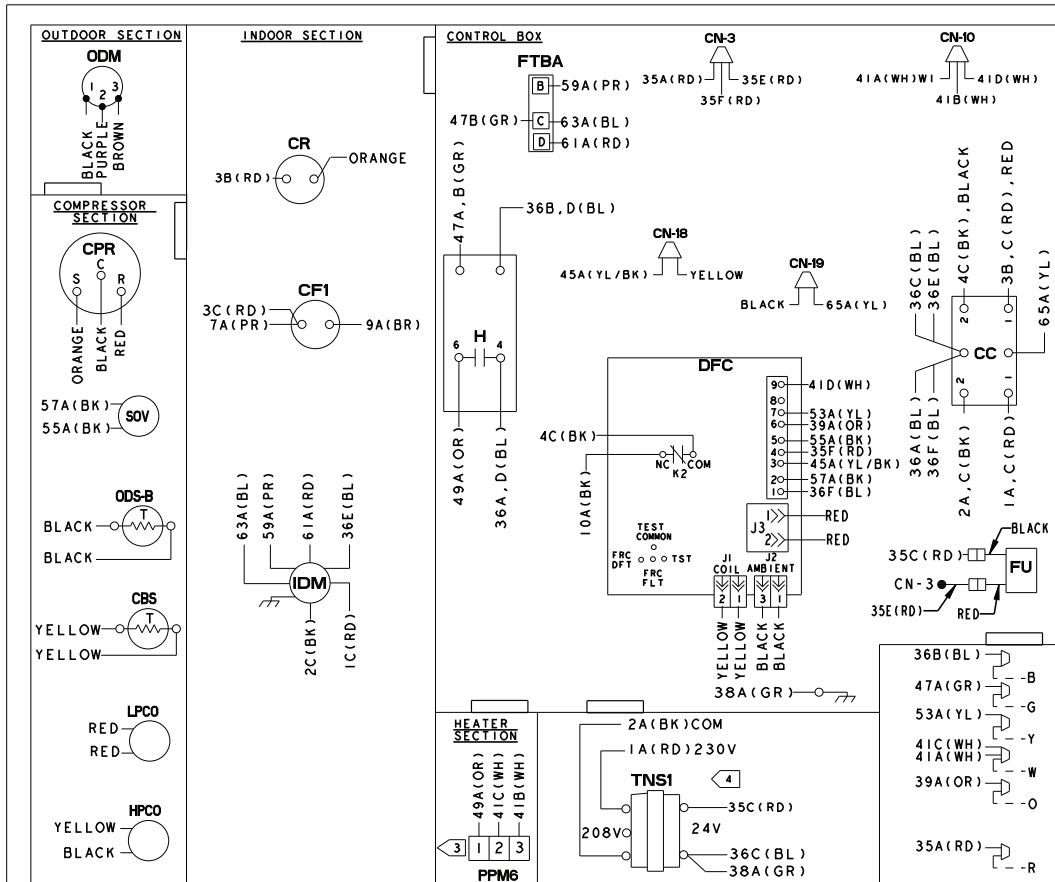

Figure 5. 4WCC4060 Model



NOTES:

- 1 CONNECTIONS SHOWN ARE FOR A TYPICAL THERMOSTAT. SEE SCHEMATIC SUPPLIED WITH THERMOSTAT FOR PROPER CONNECTIONS. LOW VOLTAGE WIRING TO UNIT MAY BE NEC CLASS 2 AND MUST BE A MINIMUM OF 18 A.W.G.
2. MAXIMUM ADDITIONAL EXTERNAL LOAD (PILOT DUTY) BETWEEN "B" AND "R" OF 0.5 AMPS, 24 VAC IS AVAILABLE WHEN A HEATER IS INSTALLED.
3. SEE WIRING DIAGRAM WITH HEATER FOR DETAILS OF HEATER WIRING.
4. FOR 208 VOLT OPERATION MAKE THE FOLLOWING WIRING CHANGES:
A: AT TNS1 REMOVE ID(RD) WIRE AND CONNECT TO 208V TERMINAL ON THE TRANSFORMER.
5. IF ANY OF THE ORIGINAL WIRE AS SUPPLIED IN THIS UNIT MUST BE REPLACED, REPLACE IT WITH APPLIANCE WIRING MATERIAL RATED AT 105° C.

ABBV	COLOR	ABBV	COLOR
BK	BLACK	PR	PURPLE
BL	BLUE	RD	RED
BR	BROWN	WH	WHITE
GR	GREEN	YL	YELLOW
OR	ORANGE		

DEVICE	DESCRIPTION	LINE
AH, BH	CONTACTOR ELECTRIC HEAT	41, 42
CBS	COIL BOTTOM SENSOR	32
CC	COMPRESSOR CONTACTOR COIL	45
CF1	OUTDOOR FAN CAPACITOR	17
CN	CONNECTOR OR WIRE NUT	
CPR	COMPRESSOR	15
CR	COMPRESSOR RUN CAPACITOR	15
DFC	DEFROST CONTROL	29-38
H	HEATER RELAY	41, 47
FTBA	FAN TERMINAL BLOCK	49
FU	FUSE	
IDM	INDOOR FAN MOTOR	24
IOL	INTERNAL OVERLOAD	
ODM	OUTDOOR FAN MOTOR	20
ODS	OUTDOOR AMBIENT SENSOR	35
PCB	PRINTED CIRCUIT BOARD	47-49
PPM6	HEATER PLUG (FEMALE)	41, 42
SOV	SWITCHOVER VALVE	38
TNS1	CONTROL POWER TRANSFORMER	28
LPCO	LOW PRESSURE SWITCH	44
HPCO	HIGH PRESSURE SWITCH	44

- C = LOW VOLTAGE COMMON
- G = ALTERNATE GROUND LOCATION
- L = LINE VOLTAGE
- N = NEUTRAL
- 1 = LOW TAP
- 2 = MEDIUM TAP
- 3 = HIGH TAP
- 4 = NOT USED
- 5 = NOT USED

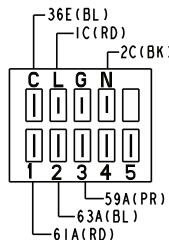

IDM CONNECTION

24 VOLT TRANSFORMER FUSE REPLACEMENT
FU 300 VOLT TYPE GMD-3.2 AMP

PRINTED FROM D758047P01

Figure 6. 4WCC4060 Model Pg 2

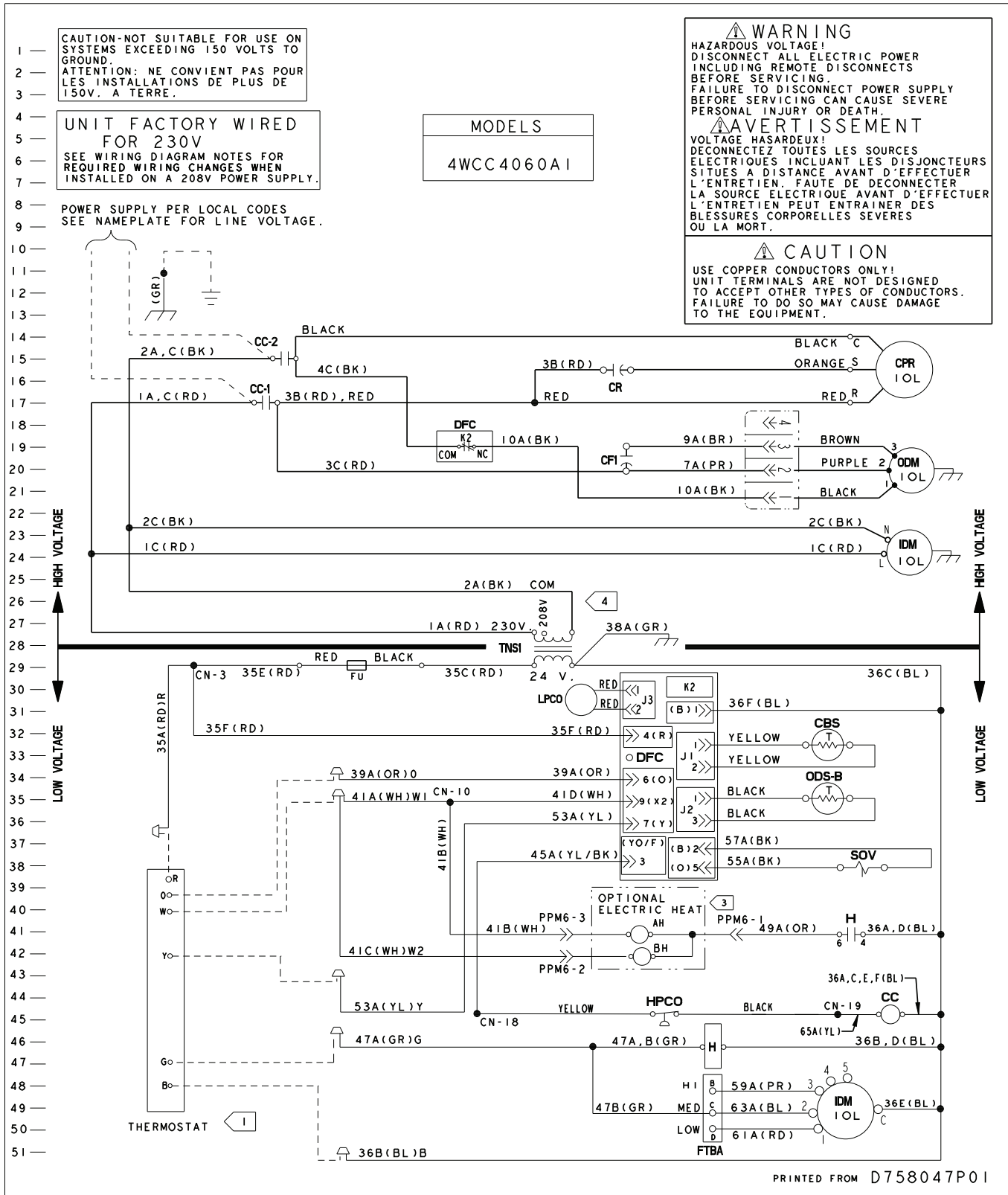

Full Perimeter Roof Mounting Curb

Figure 7. 2.0 – 3.0 Ton Models

BAYCURB050A Full Perimeter Roof Mounting Curb

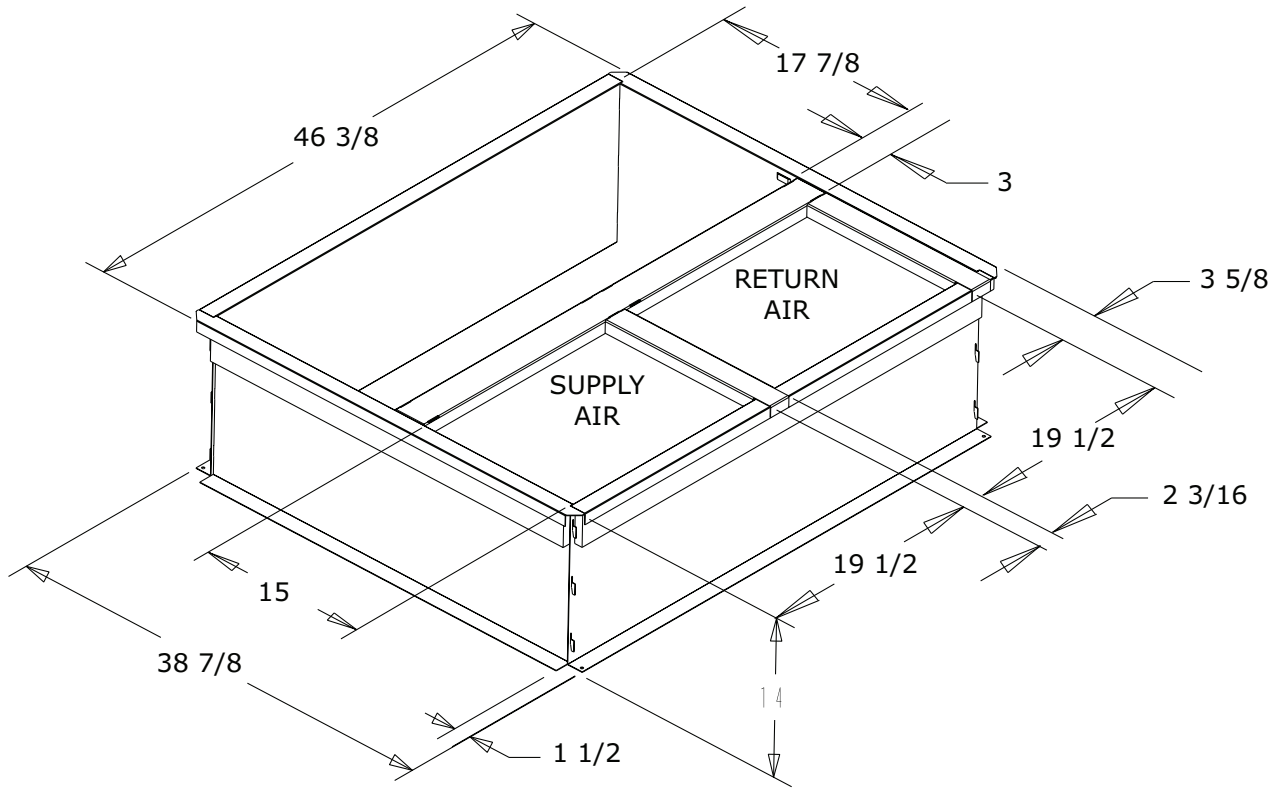

The drawings on this page are prepared by the manufacturer in order to provide detail regarding job layout only. These drawings are not intended to be used as a basis to construct, build or modify the items depicted in the drawings. The manufacturer is not responsible for the unauthorized use of these drawings and expressly disclaims any liability for damages resulting from such unauthorized use.

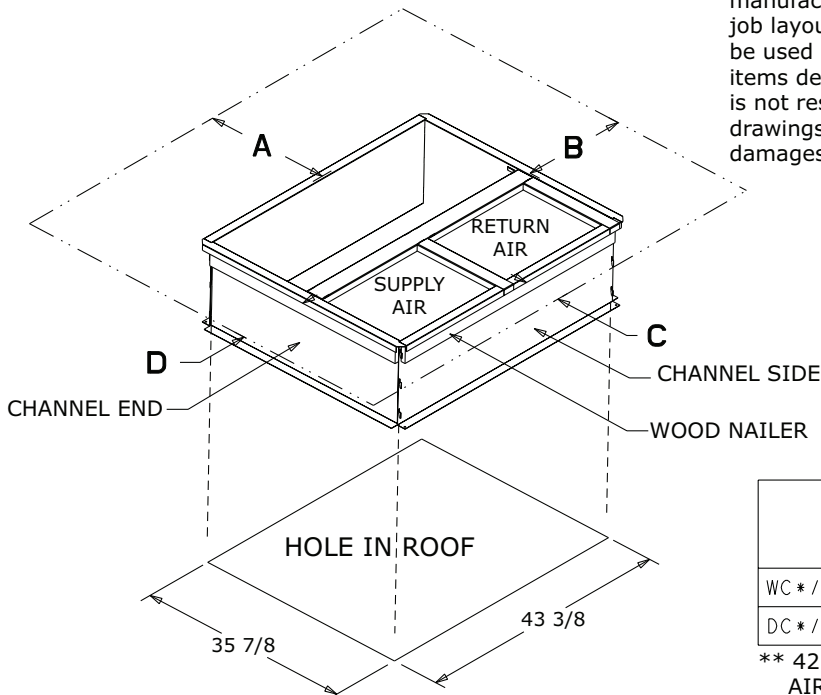

	SERVICE CLEARANCE DIMENSIONS			
	A	B	C	D
WC*/TC*	42.00	36.00	12.00**	24.00
DC*/YC*	42.00	36.00	12.00**	36.00

** 42.00 WITH ECONOMIZER WITH 25% FRESH AIR ACCESSORY

Figure 8. 3.5 – 5.0 Ton Models

BAYCURB051A Full Perimeter Roof Mounting Curb

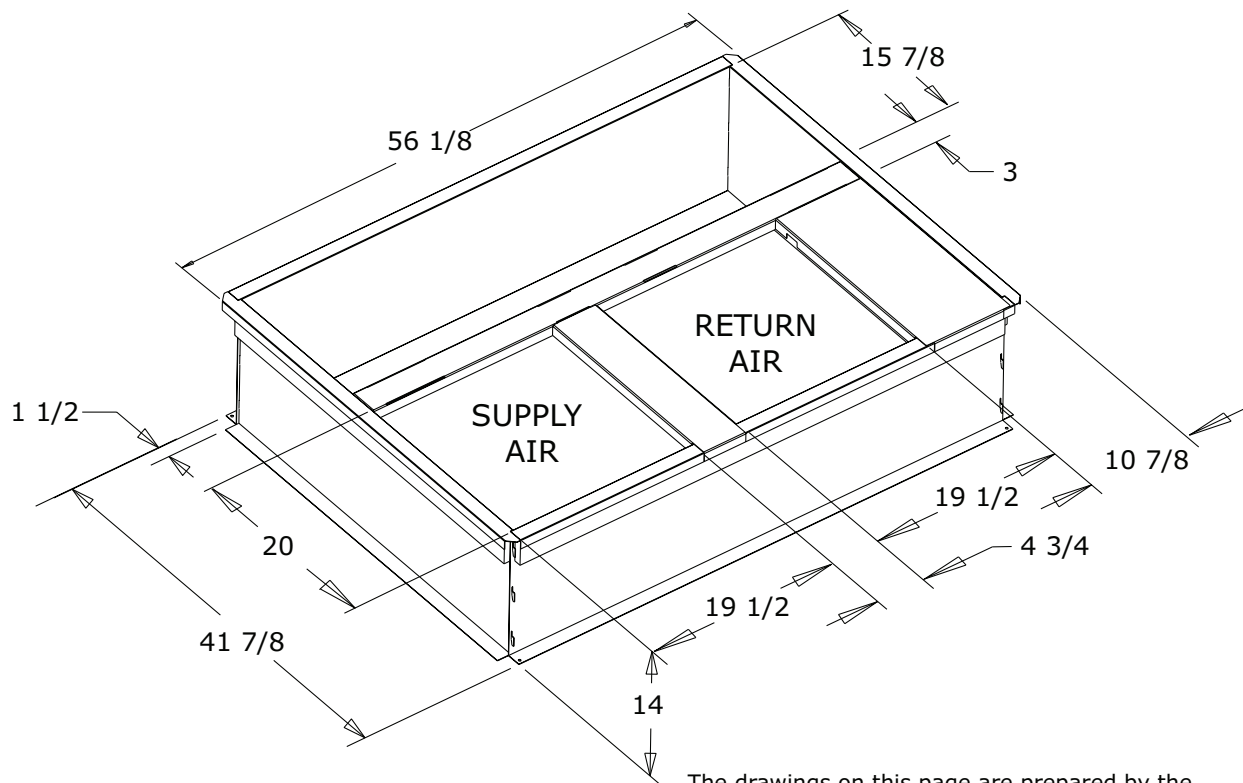

The drawings on this page are prepared by the manufacturer in order to provide detail regarding job layout only. These drawings are not intended to be used as a basis to construct, build or modify the items depicted in the drawings. The manufacturer is not responsible for the unauthorized use of these drawings and expressly disclaims any liability for damages resulting from such unauthorized use.

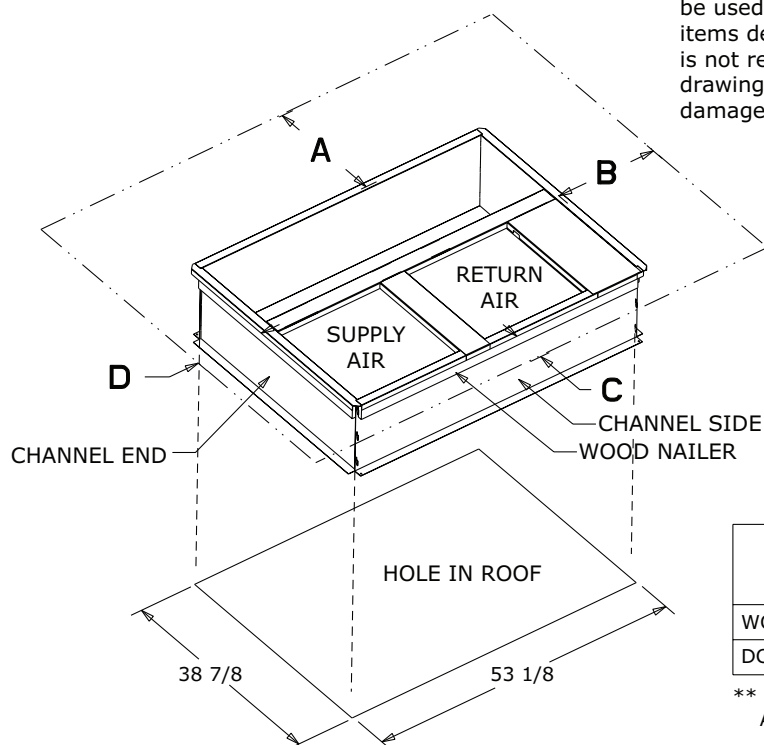

	SERVICE CLEARANCE DIMENSIONS			
	A	B	C	D
WC*/TC*	42.00	36.00	12.00**	24.00
DC*/YC*	42.00	36.00	12.00**	36.00

** 42.00 WITH ECONOMIZER WITH 25% FRESH AIR ACCESSORY

Optional Equipment – Economizer

Table 13. BAYECON101,102A Down Discharge Economizer and Rain Hood (Mounts Over Horizontal Return Air Opening)

	Economizer	Unit Application Models
	BAYECON101A	2.0 – 3.0 Ton Models
	BAYECON102A	3.5 – 5.0 Ton Models

Table 14. BAYCON200, 201A Horizontal Economizer and Rain Hood



Economizer	Models	A	B	C	D	E	F
BAYECON200A	2.0 – 3.0 Ton	22"	20"	16-7/8"	15-11/16"	11-11/16"	15"
BAYECON201A	3.5 – 5.0 Ton	26"	22-21/32"	19"	17-11/16"	14-11/16"	21-3/8"

Note: The drawings on this page are prepared by the manufacturer in order to provide detail regarding job layout only. These drawings are not intended to be used as a basis to construct, build or modify the items depicted in the drawings. The manufacturer is not responsible for the unauthorized use of these drawings and expressly disclaims any liability for damages resulting from such unauthorized use.

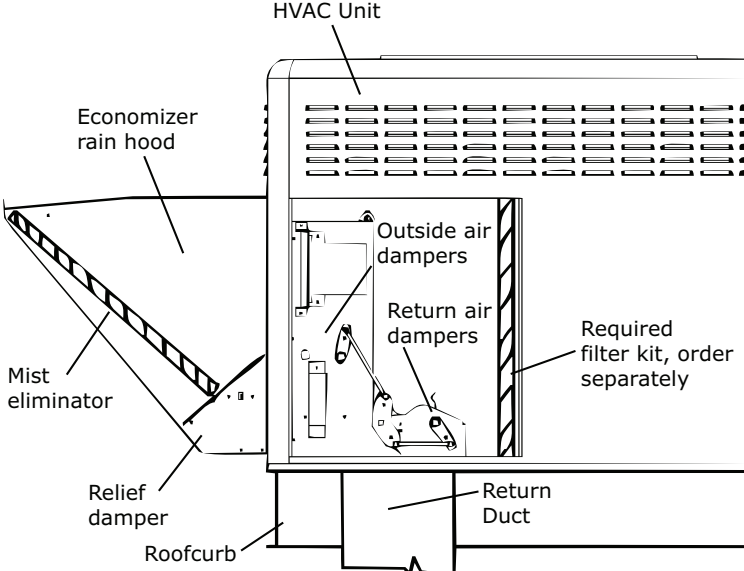
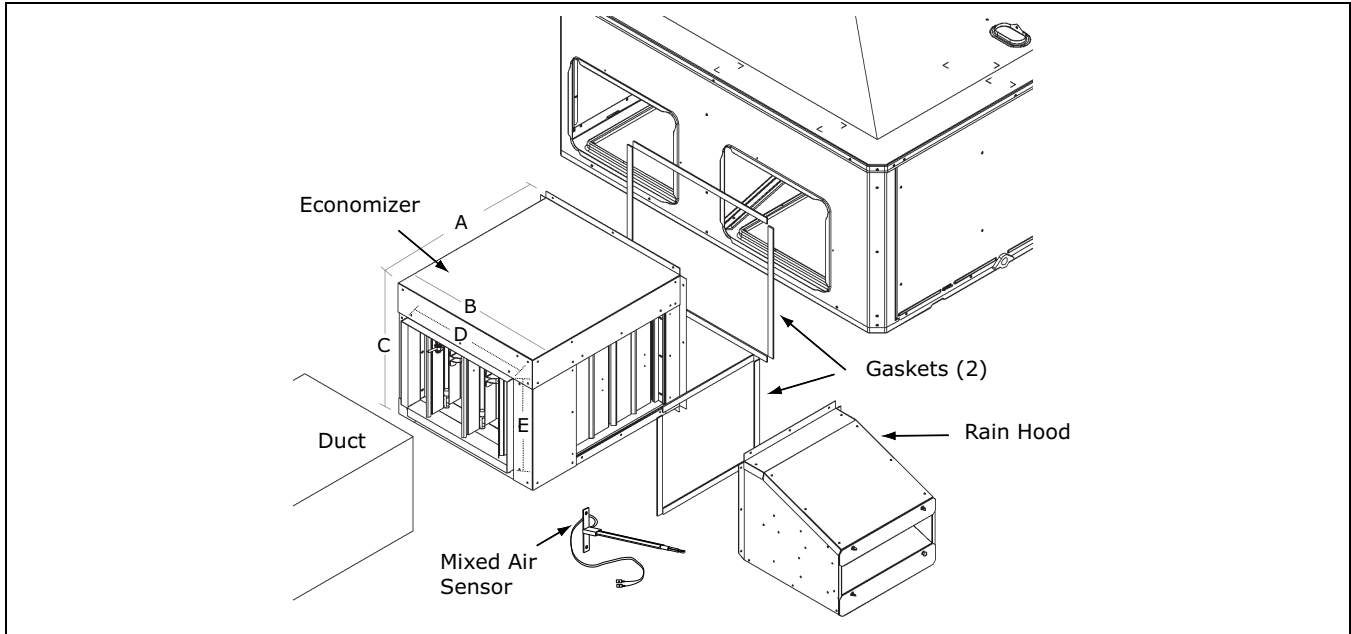

Optional Equipment – Outside Air Damper

Table 15. BAYOSAH001 and 002A

	Manual Fresh Air Model	Unit Application Models	A	B	C	D
	BAYOSAH001A	2.0 – 3.0 Ton	22-7/16"	20-11/16"	12-3/8"	9-3/16"
BAYOSAH002A	3.5 – 5.0 Ton	25-3/16"	20-11/16"	12-3/8"	9-3/16"	

Table 16. BAYDMPR101 and 102A, 25% Motorized Outside Air Damper (Mounts Over Horizontal Return Air Opening)

	Manual Fresh Air Model	Unit Application Models	A	B	C	D	E
	BAYDM-PR101A	2.0 – 3.0 Ton	15-13/16"	11-13/16"	10-1/4"	11-1/2"	12-1/4"
BAYDM-PR102A	3.5 – 5.0 Ton	18-3/16"	15-1/8"	10-1/4"	11-1/2"	12-1/4"	

Note: The drawings on this page are prepared by the manufacturer in order to provide detail regarding job layout only. These drawings are not intended to be used as a basis to construct, build or modify the items depicted in the drawings. The manufacturer is not responsible for the unauthorized use of these drawings and expressly disclaims any liability for damages resulting from such unauthorized use.

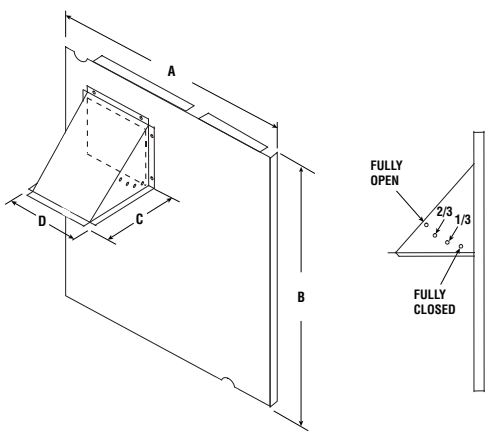
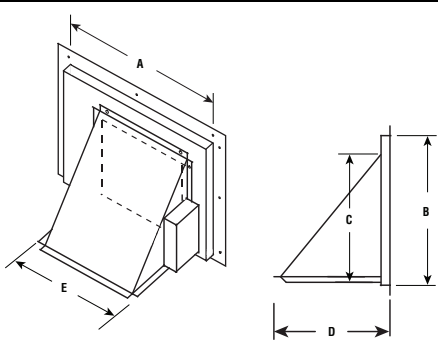

Optional Equipment — Filter Rack

**Figure 9. BAYFLTR101 Filter Rack (2.0 – 3.0 Ton Models)
BAYFLTR201 (3.5 – 5.0 Ton Models)
(Mounts in Filter/Coil Section)**

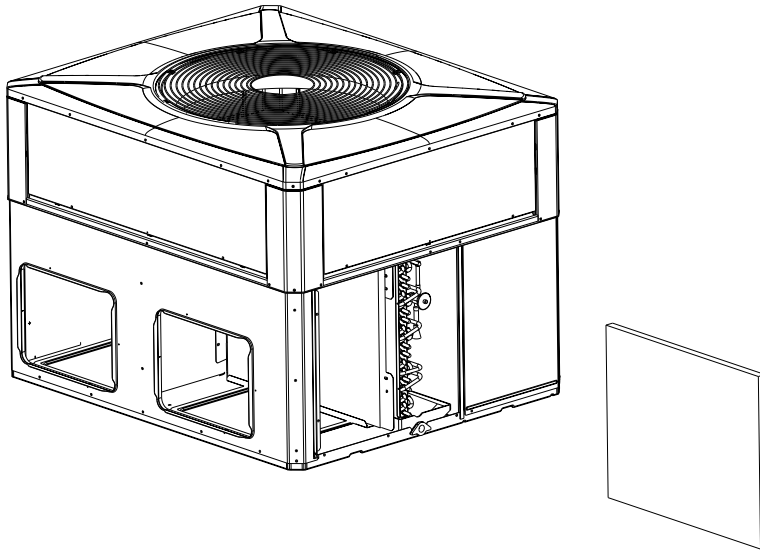

**Figure 10. BAYACCDOR1A Hinged Filter Access Door (2.0 – 3.0 Ton Models)
BAYACCDOR2A (3.5 – 5.0 Ton Models)
Replaces Filter/Coil Access Panel**

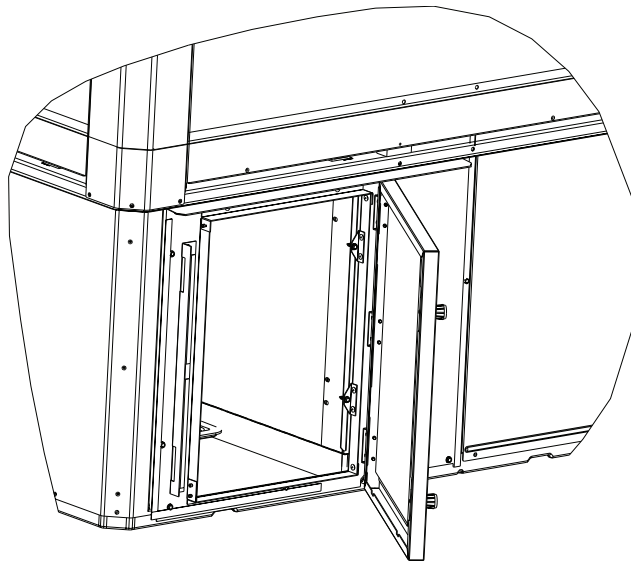

Note: The drawings on this page are prepared by the manufacturer in order to provide detail regarding job layout only. These drawings are not intended to be used as a basis to construct, build or modify the items depicted in the drawings. The manufacturer is not responsible for the unauthorized use of these drawings and expressly disclaims any liability for damages resulting from such unauthorized use.

Outline Drawings

Figure 11. 2 – 3 TON MODELS

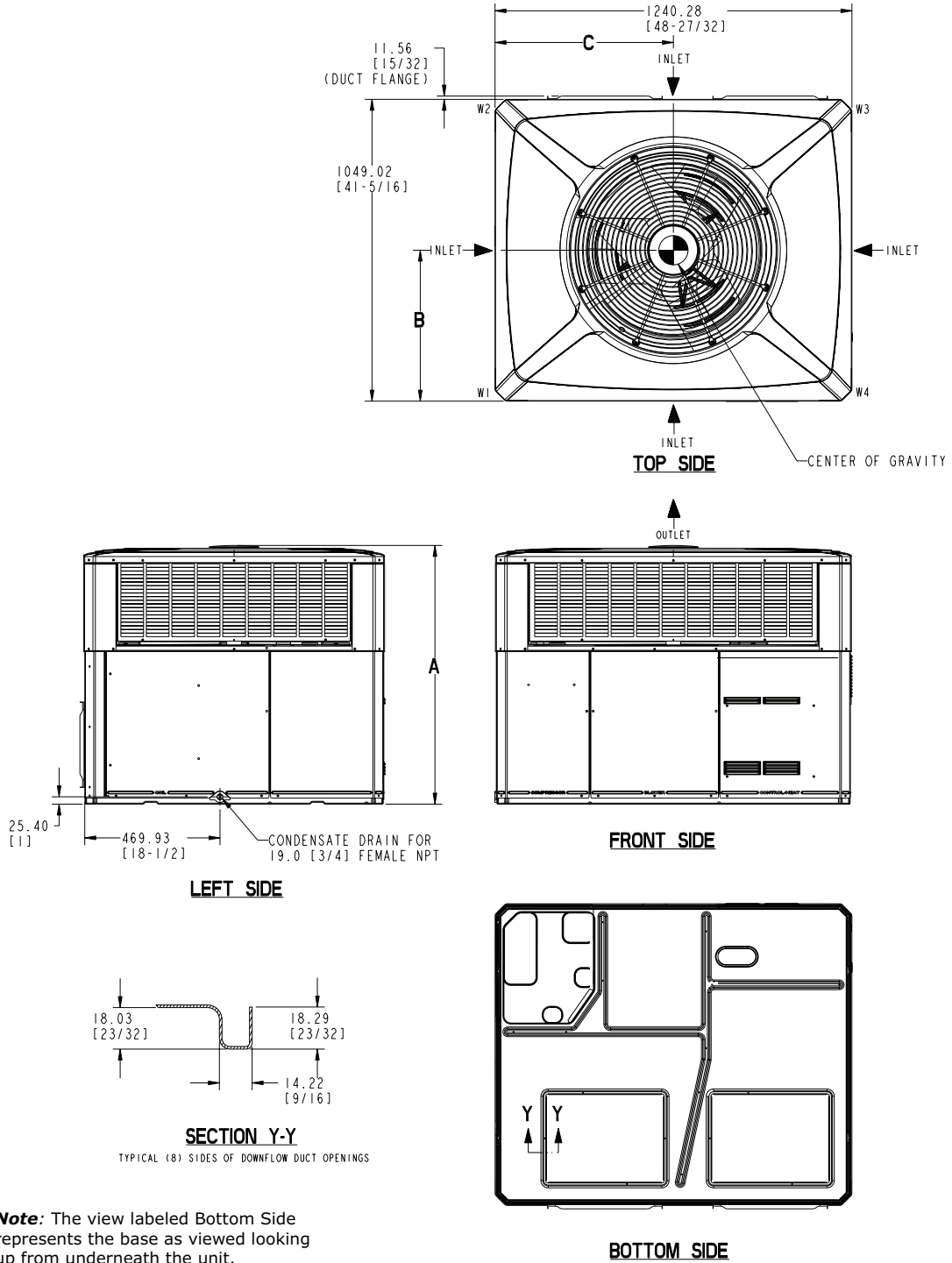

Note: The view labeled Bottom Side represents the base as viewed looking up from underneath the unit.

Figure 12. 2 – 3 TON MODELS

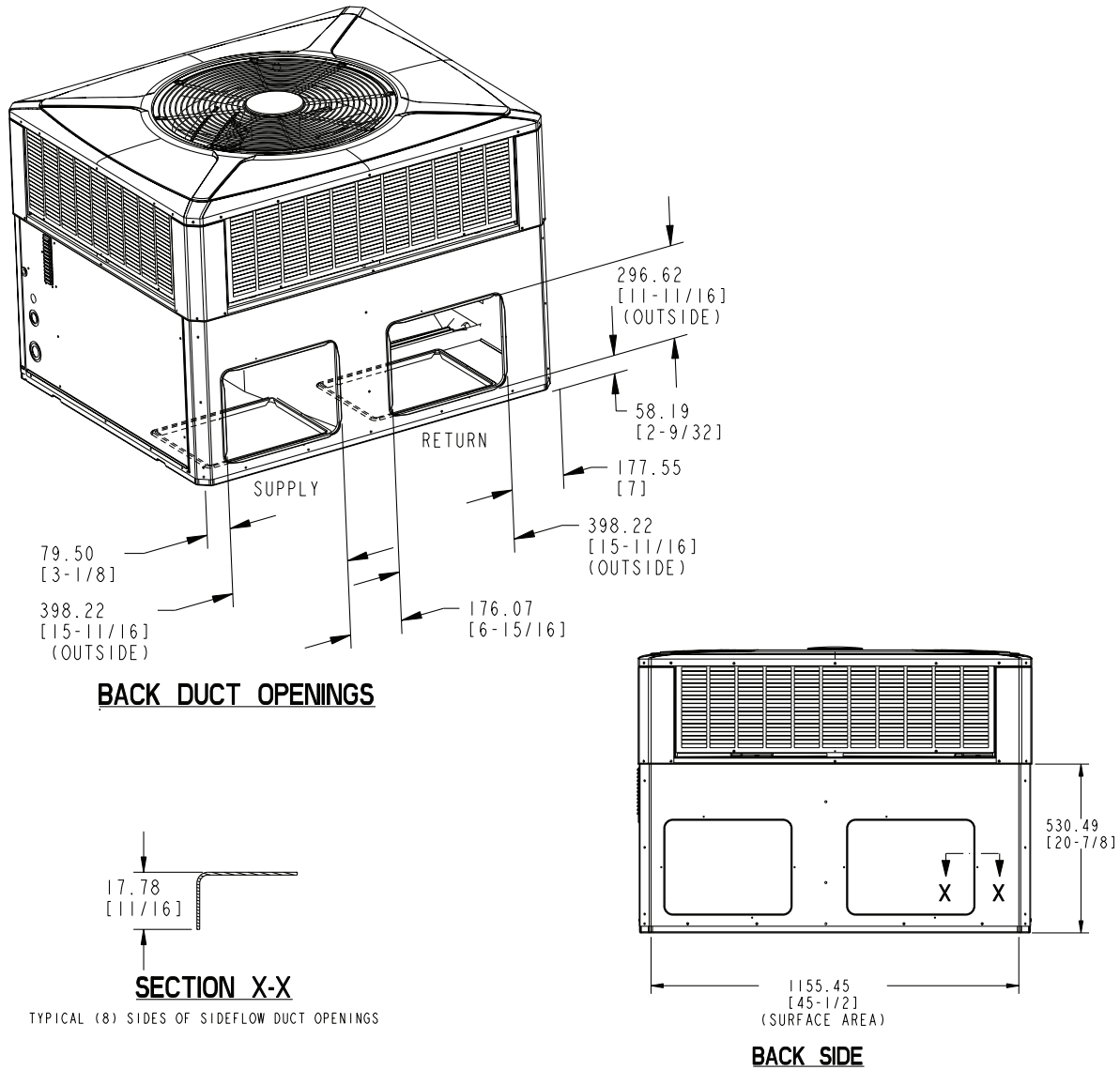

Model	Height MM/IN	APPROX. CORNER WEIGHT KG / LBS				SHIPPING WIGHT KG / LBS	TOTAL UNIT WEIGHT KG / LBS	CENTER OF GRAVITY MM/IN.		
	A	W1	W2	W3	W4			B	C	
4TCC4024	898.53 [35 - 3/8]	58.3 [129]	36.8 [81]	26.1 [58]	41.0 [90]	196.1 (432)	162.4 (358)	479.8 [18.9]	527.8 [20.8]	
4TCC4030		61.3 [135]	38.7 [85]	27.5 [61]	43.1 [95]	204.8 (451)	171.1 (377)	406.5 [16.0]	594.1 [23.4]	
4TCC4036	949.33 [37-3/8]	61.7 [136]	38.9 [86]	27.7 [61]	43.7 [96]	205.7 (453)	172.0 (379)	414.3 [16.3]	697.6 [27.5]	
4WCC4024	898.53 [35-3/8]	52.9 [117]	33.3 [73]	24.1 [53]	38.3 [84]	182.3 (402)	148.6 (328)	430 [16.9]	565.3 [22.3]	
4WCC4030		949.33 [37-3/8]	55.3 [122]	50.3 [110]	16.6 [37]	39.2 [86]	195.0 (430)	161.3 (355)	413.5 [16.3]	581 [22.9]
4WCC4036			59.6 [131]	37.3 [82]	26.6 [59]	41.7 [92]	199.0 (439)	165.3 (364)	430 [17.0]	535 [21.1]

Figure 13. 2 – 3 TON MODELS

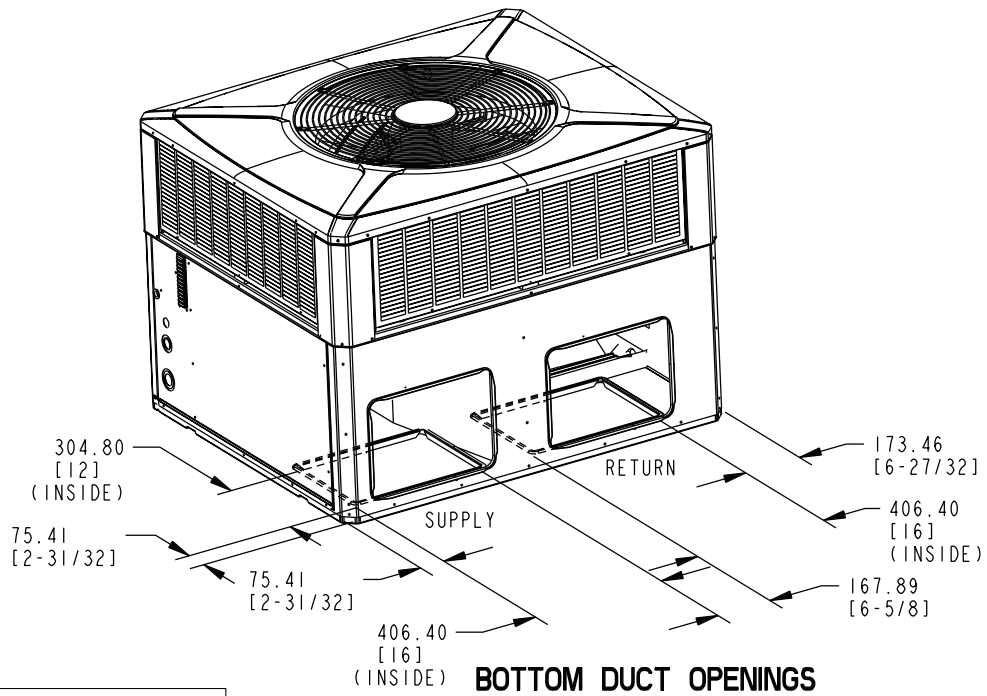

RECOMMENDED SERVICE CLEARANCE MM/IN.		
		WITH ECONOMIZER
BACK SIDE	304.8 [12]	762.0 [30]
LEFT SIDE	762.0 [30]	914.4 [36]
RIGHT SIDE	609.6 [24]	-
FRONT SIDE	1066.8 [42]	-

CLEARANCE TO COMBUSTIBLE MATERIAL MM/IN.	
BOTTOM	0
BACK SIDE	25.4 [1]
LEFT SIDE	152.4 [6]
RIGHT SIDE	152.4 [6]
FRONT SIDE	304.8 [12]
TOP	914.4 [36]

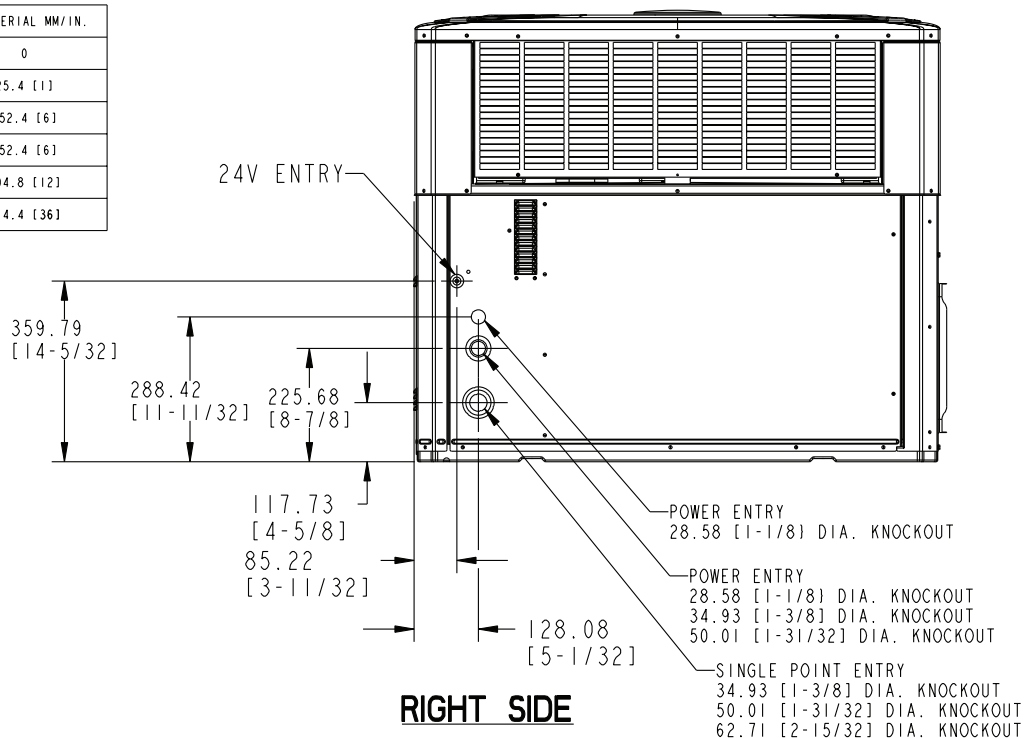
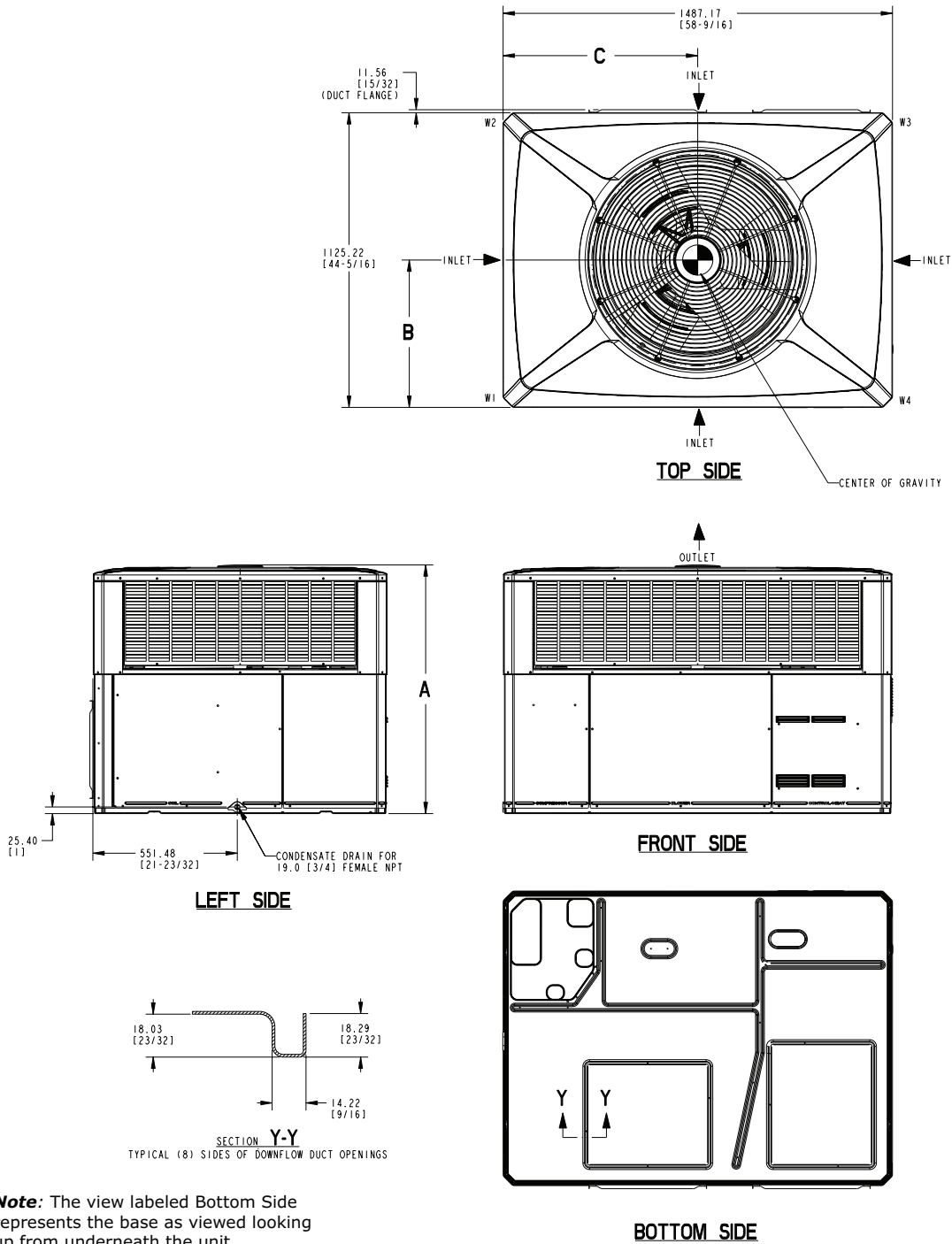
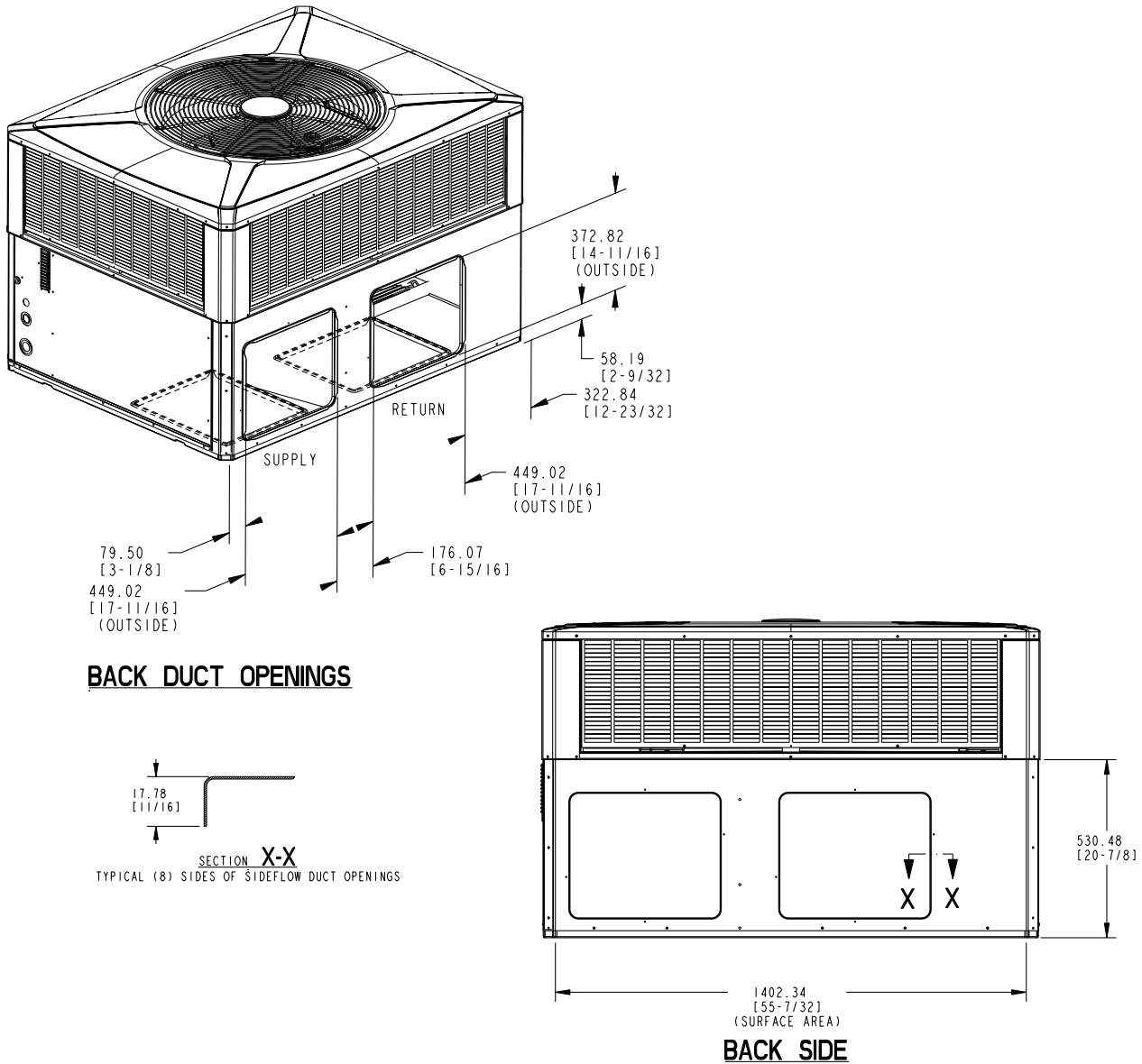

Figure 14. 3.5 – 5 TON MODELS



Note: The view labeled Bottom Side represents the base as viewed looking up from underneath the unit.

Figure 15. 3.5 – 5 TON MODELS



Model	Height MM/IN	APPROX. CORNER WEIGHT KG / LBS				SHIPPING WIGHT KG / LBS	TOTAL UNIT WEIGHT KG / LBS	CENTER OF GRAVITY MM/IN	
	A	W1	W2	W3	W4			B	C
4TCC4042	898.53 [35-3/8]	71.8 [158]	47.2 [104]	35.2 [78]	53.6 [118]	254.5 (561)	207.3 (457)	470.0 [18.5]	731.0 [28.8]
4TCC4048	1000.13 [39-3/8]	72.0 [159]	45.0 [99]	33.8 [75]	54.4 [120]	252.6 (557)	205.4 (453)	433.0 [17.0]	743.3 [29.3]
4TCC4060		78.0 [172]	46.3 [102]	34.9 [77]	59.0 [130]	265.8 (586)	218.6 (482)	414.0 [16.3]	635.0 [25.0]
4WCC4042		64.4 [142]	47.6 [105]	39.5 [87]	49.9 [110]	248.6 (547.9)	201.4 (444)	449.6 [17.7]	641.8 [25.3]
4WCC4048		68.9 [152]	40.8 [90]	30.8 [68]	52.2 [115]	240.0 (529)	192.8 (425)	414.0 [16.3]	635.0 [25.0]
4WCC4060	1050.93 [41-3/8]	79.4 [175]	47.2 [104]	35.8 [79]	59.9 [132]	269.5 (594)	222.3 (490)	414.0 [16.3]	635.0 [25.0]

Figure 16. 3.5 – 5 TON MODELS

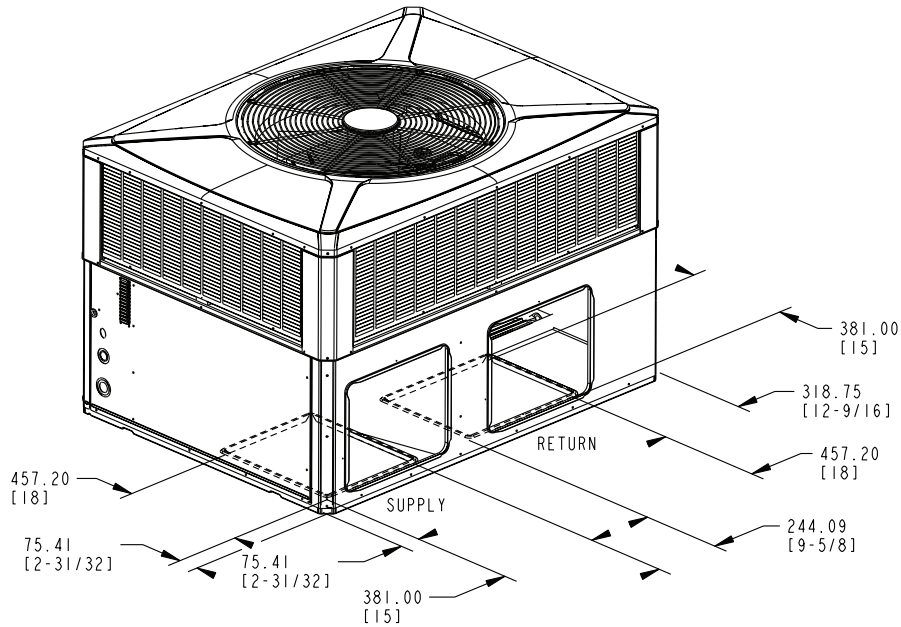

BOTTOM DUCT OPENINGS

RECOMMENDED SERVICE CLEARANCE MM/IN.		
		WITH ECONOMIZER
BACK SIDE	304.8 [12]	762.0 [30]
LEFT SIDE	914.4 [36]	1066.8 [42]
RIGHT SIDE	609.6 [24]	-
FRONT SIDE	762.0 [30]	-

CLEARANCE TO COMBUSTIBLE MATERIAL MM/IN.	
BOTTOM	0
BACK SIDE	25.4 [1]
LEFT SIDE	152.4 [6]
RIGHT SIDE	152.4 [6]
FRONT SIDE	304.8 [12]
TOP	914.4 [36]

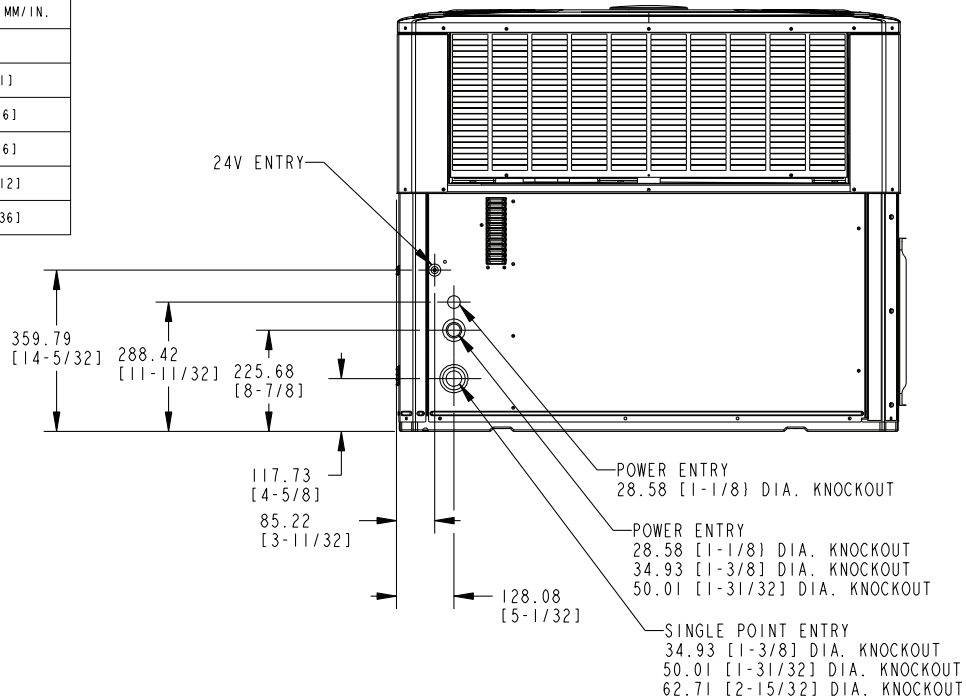

RIGHT SIDE



Mechanical Specifications

General

The units shall be horizontal airflow as shipped and convertible to downflow. All units shall be factory assembled, piped, internally wired and fully charged with refrigerant. Units shall be certified to UL Standard 1995. All units shall be factory run tested to check cooling operation, fan and blower rotation and control or TXV sequence. Units shall be designed to operate at ambient temperatures between 115°F and 55°F in cooling as manufactured. Cooling performance shall be rated in accordance with AHRI standards.

Unit Casing

All components shall be mounted in a weather-resistant steel cabinet with an enamel finish. Access panels shall be provided for unit controls and indoor coil and fans. Indoor air section compartment shall be completely insulated with fireproof, permanent, odorless fiber material. Knockouts shall be provided for utility and control connections. Drain connections shall be provided to accommodate indoor water runoff.

Compressor

The compressor shall be hermetically sealed, high efficiency scroll compressors. Internal overcurrent and over temperature protection, internal pressure relief shall be standard. Other features include centrifugal oil pump, low vibration and noise.

Refrigeration System

All units shall have refrigerant control. Service pressure tap ports and a refrigerant line filter shall be standard.

Evaporator Coil Internally enhanced 3/8" OD seamless copper tubing mechanically bonded to aluminum fins, factory pressure and leak tested at 480 – 650 psig. All units have TXV to control refrigerant flow.

Condenser Coil

The Spine Fin™ condenser coil shall be continuously wrapped, corrosion resistant all aluminum with minimum brazed joints. This coil is 3/8" OD seamless aluminum tubing glued to a continuous aluminum fin. Coils are lab tested to withstand 2,000 pounds of pressure per square inch. The outdoor coil provides low airflow resistance and efficient heat transfer. The coil is protected on all four sides by louvered panels.

Indoor Air Fan

Constant Torque, forward-curved, centrifugal wheel in a Composite Vortica® Blower housing. Motor shall have thermal overload protection and permanently lubricated motor bearings. Motor/blower assembly isolated from unit with rubber mounts.

Outdoor Fan

One direct-drive, statically and dynamically balanced propeller fan shall be used in a draw-through vertical discharge configuration. Permanently lubricated weather proof motor shall have built-in thermal overload protection.

System Controls

System controls include condenser fan, evaporator fan and compressor contactors.

Accessories Roof Curb

The roof curb shall be designed to mate with the unit and provide support and complete weathertight installation when properly installed. Adhesive back polyurethane sealing strips shall be provided to ensure an airtight seal between supply and return openings of the curb and unit. The roof curb design allows field fabricated ductwork to be connected directly to the curb. Curb ships knocked down for field assembly, and includes factory installed wood nailer strips.



Mechanical Specifications

Electric Heaters

Each heater assembly shall include power supply fusing if over 48 amps, automatic resetting limit switches and heat limiters for thermal protection. Heaters shall be provided with polarized plugs for quick connection to unit low voltage wiring. Electric heat modules shall be UL listed.

Single Source Power Entry

This accessory when used with electric heat accessory shall allow single source power connection to unit and heater combination. Single source power entry kits shall have specific matching heater(s). Kit shall include high voltage terminal blocks, fuse blocks and fuses, cut-to-length interconnecting wiring, and junction box (if required) to provide power sources with fuse protection as required for both the unit and accessory heater. Kit components shall install within the heater cabinet in the heater access section. Single source branch power circuit shall be protected and wired in accordance with local codes.

Fully Modulating Economizer

This accessory shall be field installed and be composed of the following items: 0–100 % fresh air damper, damper drive motor, fixed dry bulb enthalpy control, and low voltage pigtails for electrical connections. Solid state enthalpy or differential enthalpy control is optional. Economizer operations shall be controlled by the preset position of the enthalpy control. A barometric relief damper shall be standard with the economizer and provide a pressure operated damper that shall be gravity closing and prohibit entrance of outside air on equipment "off" cycle. Economizer requires BAYRLAY004A relay kit to interface the economizer to the heat pump.

Manual Outside Air Dampers

Rain hood and screen shall be field installed. Suitable for up to 25% outside air.

Start Kit

Extra compressor starting capacity for single phase equipment.

Control Options

Standard Indoor Thermostats

Two stage heating/cooling or one stage heating/cooling thermostats shall be available in either manual or automatic changeover.

Programmable Electronic Night Setting Thermostat

Programmable electronic thermostat shall provide heating setback and cooling setup with 7–day programming capability. 1H/1C or 2H/2C models available.



Trane - by Trane Technologies (NYSE: TT), a global innovator - creates comfortable, energy efficient indoor environments for commercial and residential applications. For more information, please visit trane.com or tranetechnologies.com.



The AHRI Certified mark indicates Trane U.S. Inc. participation in the AHRI Certification program. For verification of individual certified products, go to ahridirectory.org.

Trane has a policy of continuous data improvement and it reserves the right to change design and specifications without notice. We are committed to using environmentally conscious print practices.