

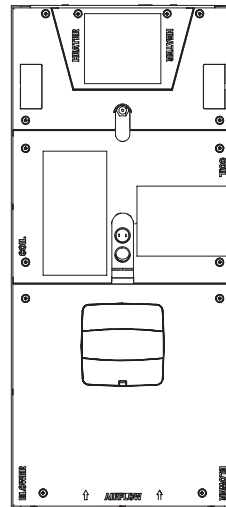

# Product Data

## Multi-position, Upflow, Horizontal Left, or Horizontal Right, Modular Air Handlers 50 HZ Convertible Air Handlers Model: Series 2 Air Handlers 3 - 5 ton

- GAF2A0A36S3ASC
- GAM2A0C48S4ASC
- GAM2A0C60S5ASC



GAF2A0A36S3ASC

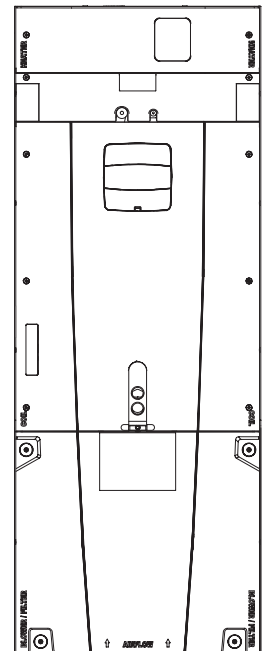

GAM2A0C48S4ASC  
GAM2A0C60S5ASC

*Note: "Graphics in this document are for representation only.  
Actual model may differ in appearance."*



# Features and Benefits

---

## GAF2

- Unique Cabinet Design
  - Double Wall Foamed and Formed Cabinet System
  - Water Proof Cabinet Design
  - R-4.2 Insulating Value (Avg. Insulating Value R-8)
  - Composite Foamed Cabinet Doors
  - Sweat Eliminating Cabinet Design
  - Loose Fiber Eliminating Cabinet Design
  - Smooth Cleanable Cabinet Design
  - 2% or Less air leakage
  - Precision Applied Durable Door Seals
- Multi-Position Upflow/ Horizontal Left / Horizontal Right
- Front Return Option
- Braze in Refrigerant Connection
- Primary/Secondary Condensate Connections
- Vortica Blower with Integrated Slide Deck for Easy Removal
- Polarized Plug connections on Blower
- Aluminum Coil with Integrated Slide Deck for Easy Removal
- Slide in Electric Heaters
- Polarized Plug connections for Electric Heater
- Labeled Panels and connections
- Guide for 1-1/4" to 1" And 3/4" to 1/2" Conduit connection on Top
- R-410A Thermal Expansion Valve (TXV)
- Convertible to R-22 using optional accessory TXV conversion kit.
- Low Voltage Color Coded Wires
- Enhanced Coil Fin Patented
- Blow Through Design
- PSC 3 Speed Motor
- Maximum Width of 17.5"
- Compact 20.8" depth with doors removed
- Integrated Horizontal Drain pans
- Single Color
- Fused 24V Power

## GAM2

- Unique Cabinet Design
    - Double Wall Foamed and Formed Cabinet System
    - Water Proof Cabinet Design
    - R-4.2 Insulating Value (Avg. Insulating Value R-8.2)
    - Composite Foamed Cabinet Doors
    - Sweat Eliminating Cabinet Design
    - Loose Fiber Eliminating Cabinet Design
    - Smooth Cleanable Cabinet Design
    - 2% or Less air leakage
    - Precision Applied Durable Door Seals
    - Tool-free Fasteners on Blower/Filter Door
    - Modular Cabinet
  - Multi-Position Upflow / Downflow / Horizontal Left / Horizontal Right
  - Braze in Refrigerant Connection
  - Primary/Secondary Condensate Connections
  - Premarked Conduit Connection Locations
  - Vortica Blower with Integrated Slide Deck for Easy Removal
  - Polarized Plug connections on Blower
  - Control Protection Pocket
  - Aluminum Coil with Integrated Slide Deck for Easy Removal
  - Slide in Electric Heaters
  - Polarized Plug connections for Electric Heater
  - Labeled Panels and connections
  - 1-1/4" to 1" And 3/4" to 1/2" Conduit connection on Left, Right and Top
  - Molded in 1" Standard Filter rail
  - R-410A Thermal Expansion Valve (TXV)
  - Convertible to R-22 using optional accessory TXV conversion kit.
  - Low Voltage Terminal Connection Point
  - Enhanced Coil Fin Patented
  - Blow Through Design
- PSC 3 Speed Motor on 3.5 & 4 ton models
  - Constant torque ECM Motor on 5 ton model
  - Maximum Width of 23.5"
  - Compact 20.8" depth with doors removed
  - Integrated Horizontal Drain pans
  - Single Color
  - Fused 24V Power
  - Safety Door Switch



# Contents

---

<b>Features and Benefits</b>	<b>2</b>
Optional Equipment	<b>4</b>
<b>Unique Cabinet Design Features and Benefits</b>	<b>5</b>
<b>General Data</b>	<b>7</b>
GAF2A0A36S3ASC	<b>7</b>
GAM2A0C48S4ASC	<b>7</b>
GAM2A0C60S5ASC	<b>7</b>
<b>Performance Data</b>	<b>8</b>
<b>Wiring Diagrams</b>	<b>12</b>
<b>Field Wiring</b>	<b>15</b>
<b>Convertibility</b>	<b>17</b>
<b>Dimensions</b>	<b>19</b>



# Optional Equipment

## OPTIONAL EQUIPMENT FOR GAM2 AND GAF2 50 HZ AIR HANDLERS

GAM2 Accessory Number	Description	Fits Cabinet Size
BAYSUPFLGCA	Supply Duct Flange C	C
BAYRETFLGCA	Return Duct Flange C	C
BAYFLR2220A	High Velocity Filter Kit, 22" X 20' X 1" (10 filters)	C
TASB235SB	Plenum Stand with Integrated Sound Baffle C	C
BAYSRKIT100A	Side Return Kit	C
TASSBK235	Sound Baffle Kit 23.5" Cabinet	C
BAYFRKIT235	Front Return Kit for 23.5" Cabinet	C
BAYICKIT01A	Internal Condensate Switch Kit	C
BAYSPEKT200A	Single Point Power Entry Kit	C
BAYATXV4248	R-22 TXV conversion kit	GAM2A0C48S4ASC
BAYATXV6060	R-22 TXV conversion kit	GAM2A0C60S5ASC
BAYHHKIT001A	Horizontal Hanger Kit	C
BAYUVCLK001A	UVC Lights	C
BAYLVKIT100A	Low Voltage Conduit Entry Kit	C
BAYINSKT235A	Sound Insulation Kit for 23.5" Cabinet	C
BAYCNDPIP01A	3/4" PVC Threaded Pipe Kit Foam Seal (10 per box)	A to C
GAF2 Accessory Number ①	Description	Fits Cabinet Size
BAYSFSCABAA	Supply Duct Flange A1	A1
BAYRETFLGAA	Return Duct Flange A	A1
TASB175SB	Plenum Stand A with Sound Baffle	A1
BAYFRKIT100	Front Return Kit	A1
BAYBRFBX100	Bottom Return Filter Box	A1
BAYWMKIT001	Wall Mount Kit	A1
BAYLVKIT100A	Low Voltage Conduit Entry Kit	A1
BAYATXV1836A	R-22 TXV Conversion Kit	A1

① GAF2A0A36 A1 Cabinet is one piece 17.5" wide

# GAF2 Unique Cabinet Design Features and Benefits

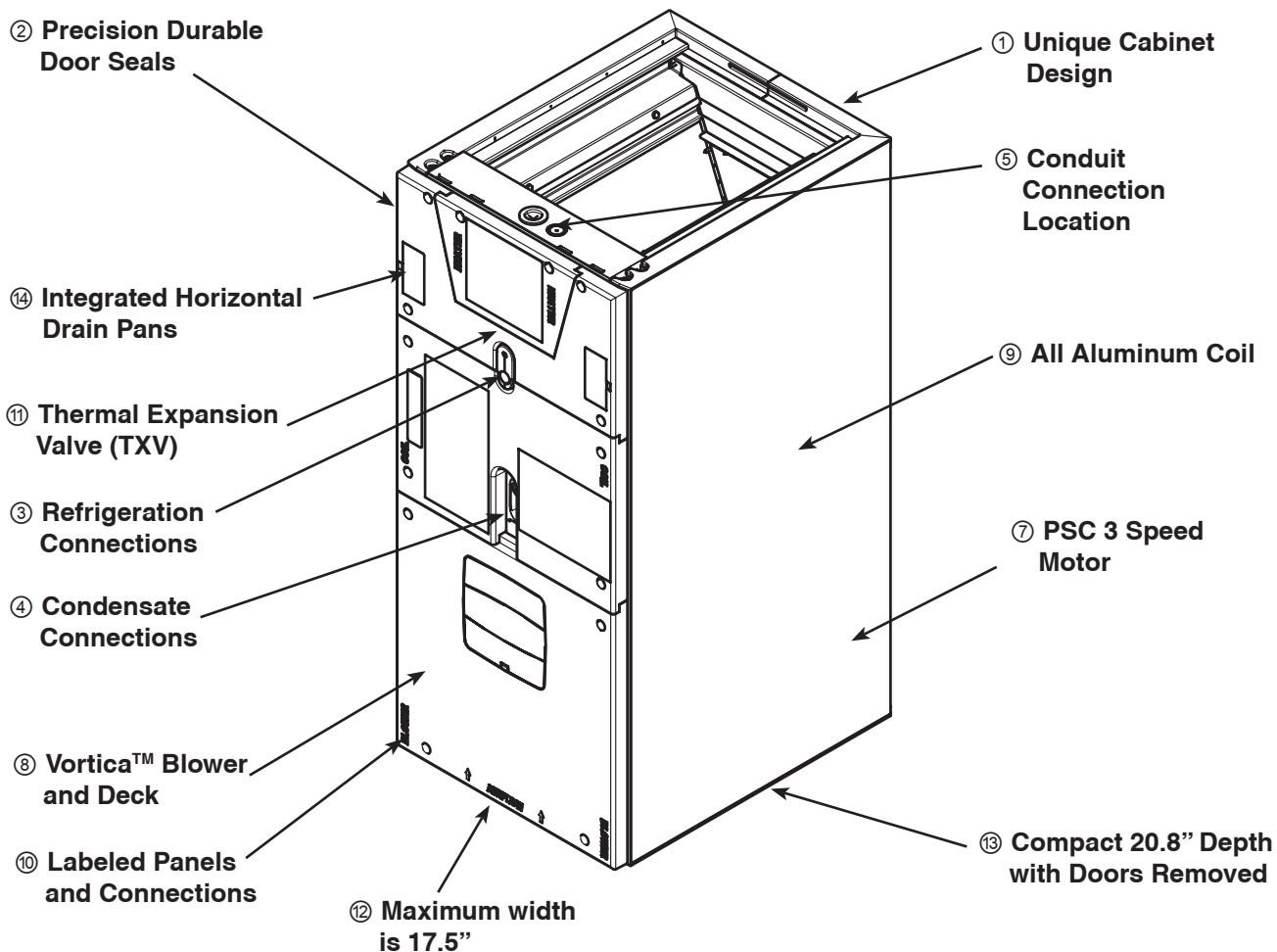

## ① Unique Cabinet Design

- Double wall foamed cabinet system
- Waterproof Cabinet Design
- R-4.2 Insulating Value (Avg. Insulating Value R-8)
- Composite Foamed Cabinet Doors
- Sweat Eliminating Cabinet Design
- Loose Fiber Eliminating Design
- Smooth Cleanable Cabinet Design
- 2% or Less air leakage

## ② Precision Durable Door Seals

## ③ Brazed Refrigeration Connections

## ④ Primary/Secondary Condensate Connections

## ⑤ Conduit Connection - Conduit Connection on Top

## ⑦ PSC 3 Speed Motor

## ⑧ Vortica™ Blower and Deck - Polarized Plug on Blower

## ⑨ All Aluminum Coil

- Integrated Slide Deck for Easy Removal
- Polarized Plug connections on Coil TXV
- Patented Enhanced Coil Fin

## ⑩ Labeled Panels and Connections

## ⑪ R-410A Thermal Expansion Valve (TXV)

## ⑫ Maximum width is 17.5"

## ⑬ Compact 20.8" Depth with Doors Removed

## ⑭ Integrated Horizontal Drain Pans

# GAM2 Unique Cabinet Design Features and Benefits

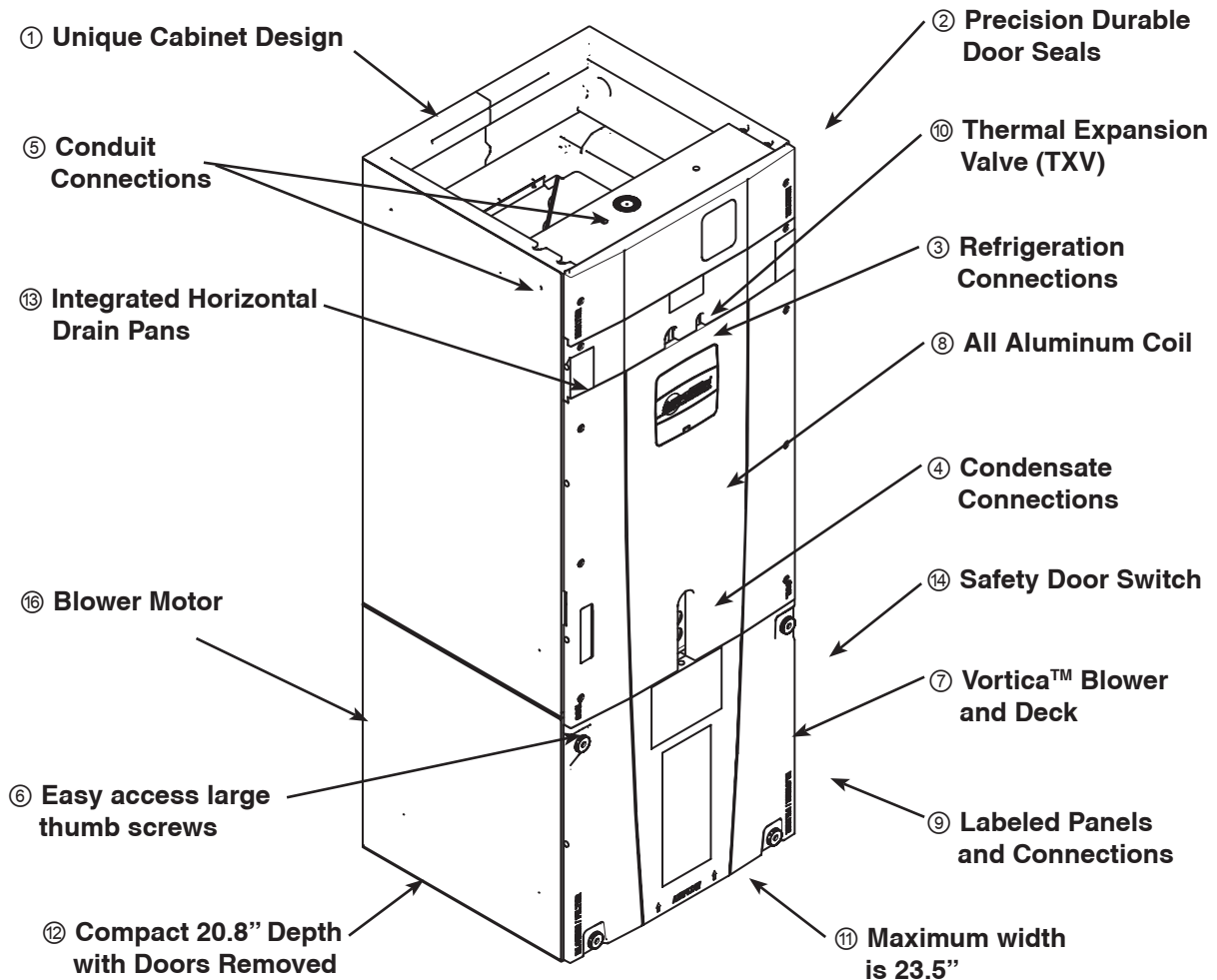

## ① Unique Cabinet Design

- Double wall foamed cabinet system
- Waterproof Cabinet Design
- R-4.2 Insulating Value (Avg Insulating Value R-8.2)
- Composite Foamed Cabinet Doors
- Sweat Eliminating Cabinet Design
- Loose Fiber Eliminating Design
- Smooth Cleanable Cabinet Design

## ② Precision Durable Door Seals

## ③ Refrigeration Connections

## ④ Condensate Connections

## ⑤ Premarked Conduit Connection Locations - Conduit Connections on Left, Right, and Top

## ⑥ Easy access large thumb screws

## ⑦ Vortica™ Blower and Deck - Polarized Plug on Blower

## ⑧ All Aluminum Coil

- Integrated Slide Deck for Easy Removal
- Polarized Plug connections on Coil EEV
- Patented Enhanced Coil Fin

## ⑨ Labeled Panels and Connections

## ⑩ R-410A Thermal Expansion Valve (TXV)

## ⑪ Maximum width is 23.5"

## ⑫ Compact 20.8" Depth with Doors Removed

## ⑬ Integrated Horizontal Drain Pans

## ⑭ Safety Door Switch - Fused 24V Power

## ⑮ Modular Cabinet

## ⑯ PSC 3 Speed Motor on 4 ton models or Constant torque ECM Motor on 5 ton model



# General Data

## PRODUCT SPECIFICATIONS

MODEL	GAF2A0A36S3ASC	GAM2A0C48S4ASC	GAM2A0C60S5ASC
<b>RATED VOLTS/PH/HZ.</b>	220-240/1/50	220-240/1/50	220-240/1/50
<b>RATINGS</b>	See O.D. Specifications	See O.D. Specifications	See O.D. Specifications
<b>INDOOR COIL — Type</b>	Plate Fin	Plate Fin	Plate Fin
Rows — F.P.I.	3 - 14	3 - 14	4 - 14
Face Area (sq. ft.)	3.21	5.50	5.50
Tube Size (in.)	3/8	3/8	3/8
Refrigerant Control	TXV	TXV	TXV
Drain Conn. Size (in.) <sup>①</sup>	3/4 NPT	3/4 NPT	3/4 NPT
<b>DUCT CONNECTIONS</b>	See Outline Drawing	See Outline Drawing	See Outline Drawing
<b>INDOOR FAN — Type</b>	Centrifugal	Centrifugal	Centrifugal
Diameter-Width (In.)	11 X 8	11 X 10	11 X 10
No. Used	1	1	1
Drive - No. Speeds	Direct - 3	Direct - 3	Direct - 5 <sup>②</sup>
CFM vs. in. w.g.	See Fan Performance Table	See Fan Performance Table	See Fan Performance Table
No. Motors — H.P.	1 - 1/2	1 - 1/2	1 - 1
Motor Speed RPM	1075	1075	1050
Volts/Ph/Hz	220-240/1/50	220-240/1/50	220-240/1/50
F.L. Amps - L.R. Amps	2.4 - 3.8	3.1 - 5.5	7.6 - n/a
<b>FILTER</b>			
Filter Furnished?	No	No	No
Type Recommended	Throwaway	Throwaway	Throwaway
No.-Size-Thickness	1 - 16 X 20 - 1 in.	1 - 20 X 22 - 1 in.	1 - 20 X 22 - 1 in.
<b>REFRIGERANT</b>	<b>R-410A</b> <sup>③</sup>	<b>R-410A</b> <sup>④</sup>	<b>R-410A</b> <sup>⑤</sup>
Ref. Line Connections	Brazed	Brazed	Brazed
Coupling or Conn. Size — in. Gas	3/4	7/8	7/8
Coupling or Conn. Size — in. Liq.	3/8	3/8	3/8
<b>DIMENSIONS</b>			
	H x W x D	H x W x D	H x W x D
Crated (In.)	40.5 x 20 x 24.5	58 x 25.5 x 24.5	62.8 x 25.5 x 24.5
Uncrated	39.5 x 17.5 x 21.8	56.9 x 23.5 x 21.8	61.7 x 23.5 x 21.8
<b>WEIGHT</b>			
Shipping (Lbs.)/Net (Lbs.)	122/112	155/143	171/159

① 3/4" Male Plastic Pipe (Ref.: ASTM 1785-76)

② Constant torque Motor

③ R-22 requires TXV change. Use R-22 TXV conversion kit BAYATXV1836A.

④ R-22 requires TXV change. Use R-22 TXV conversion kit BAYATXV4248A.

⑤ R-22 requires TXV change. Use R-22 TXV conversion kit BAYATXV6060A.



**TRANE®**

# Performance Data

**GAF2A0A36 AIRFLOW PERFORMANCE TABLE**

AIRFLOW PERFORMANCE			
GAF2A0A36S3ASC			
EXTERNAL STATIC (in w.g)	Speed Taps – 220 VOLTS (50Hz)		
	3	2 †	1
0	1040	1010	983
0.1	1024	998	975
0.2	978	955	927
0.3	925	900	880
0.4	869	845	819
0.5	808	780	757
0.6	734	715	692
0.7	651	625	593
0.8	545	520	498
0.9	439	415	395
1.0	247	241	224

NOTES:  
 1. Values are with wet coil and without filters.  
 2. Contact your particular filter manufacturer for pressure drop data  
 3. † Factory Setting

**Note:** Heating and cooling speeds are the same, factory set at Speed Tap #2.





# Performance Data

**GAM2A0C48 AIRFLOW PERFORMANCE TABLE**

AIRFLOW PERFORMANCE			
GAM2A0C48S4ASC			
EXTERNAL STATIC (in w.g)	AIRFLOW (CFM)		
	Speed Taps – 220 VOLTS (50Hz)		
	3	2 †	1
0	1897	1815	1728
0.1	1827	1757	1676
0.2	1756	1687	1615
0.3	1682	1617	1552
0.4	1568	1532	1475
0.5	1476	1441	1390
0.6	1379	1340	1291
0.7	1258	1220	1150
0.8	1090	1050	984
0.9	915	891	783
1	682		

NOTES:  
 1. Values are with wet coil and without filters.  
 2. Contact your particular filter manufacturer for pressure drop data.  
 3. † Factory Setting

**Note:** Heating and cooling speeds are the same, factory set at Speed Tap #2.



# Performance Data

**GAM2A0C60 AIRFLOW PERFORMANCE TABLE**

AIRFLOW PERFORMANCE					
GAM2A0C60S5ASC					
EXTERNAL STATIC (in w.g)	AIRFLOW (CFM)				
	Speed Taps – 220 VOLTS (50Hz)				
	5	4 †	3	2	1
0	2161	1925	1885	1673	1624
0.1	2140	1903	1842	1635	1578
0.2	2110	1871	1807	1593	1540
0.3	2073	1833	1771	1552	1502
0.4	2023	1805	1728	1513	1457
0.5	1963	1766	1691	1468	1417
0.6	1900	1725	1650	1433	1373
0.7	1829	1688	1612	1397	1332
0.8	1742	1633	1572	1354	1290
0.9	1648	1579	1530	1314	1245
1.0	1547	1528	1493	1274	1206

NOTES:  
 1. Values are with wet coil and without filters.  
 2. Contact your particular filter manufacturer for pressure drop data.  
 3. † Factory Setting

**Note:** Heating and cooling speeds are the same, factory set at Speed Tap #4 for the CTM motor.

# Performance Data

## DISTANCE FROM BELLY BAND TO SHAFT FACE OF MOTOR FOR MINIMUM VIBRATION

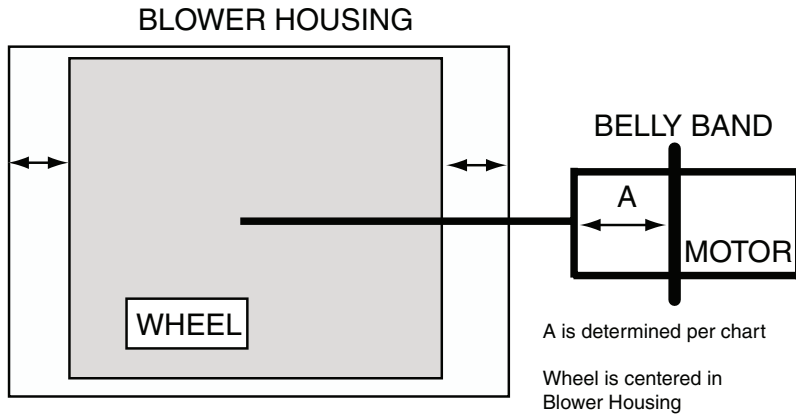

MODEL	DIM "A"
GAF2A0A36S3ASC	1-11/16
GAM2A0C48S4ASC	2-13/16
GAM2A0C60S5ASC	2-1/4

# WIRING DIAGRAM FOR GAF2A0A36S AIR HANDLERS

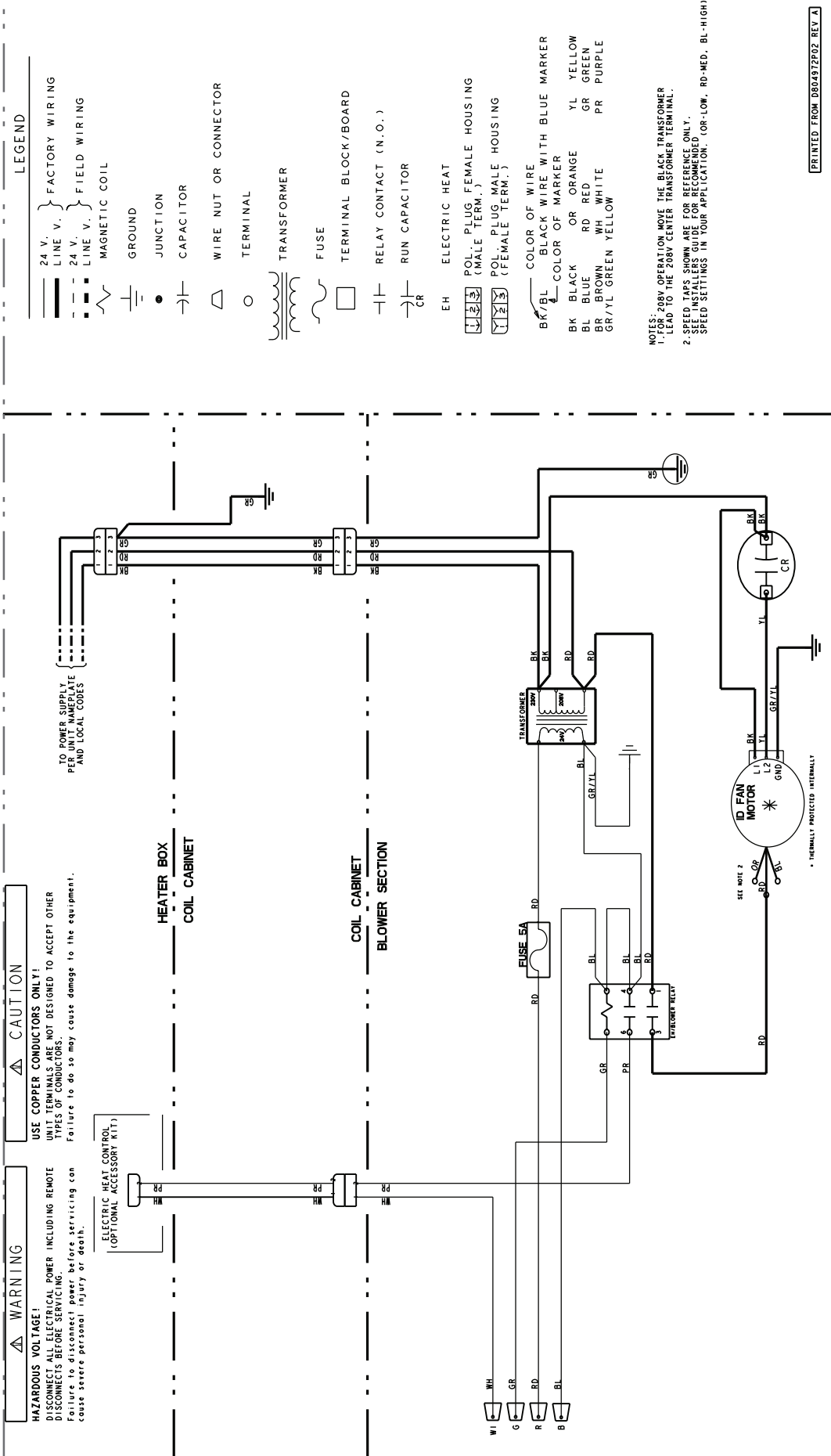

PRINTED FROM DB04972P02 REV A





# Field Wiring

## GAF2 AND GAM2 50 HZ AIR HANDLERS WITH SINGLE SPEED COOLING

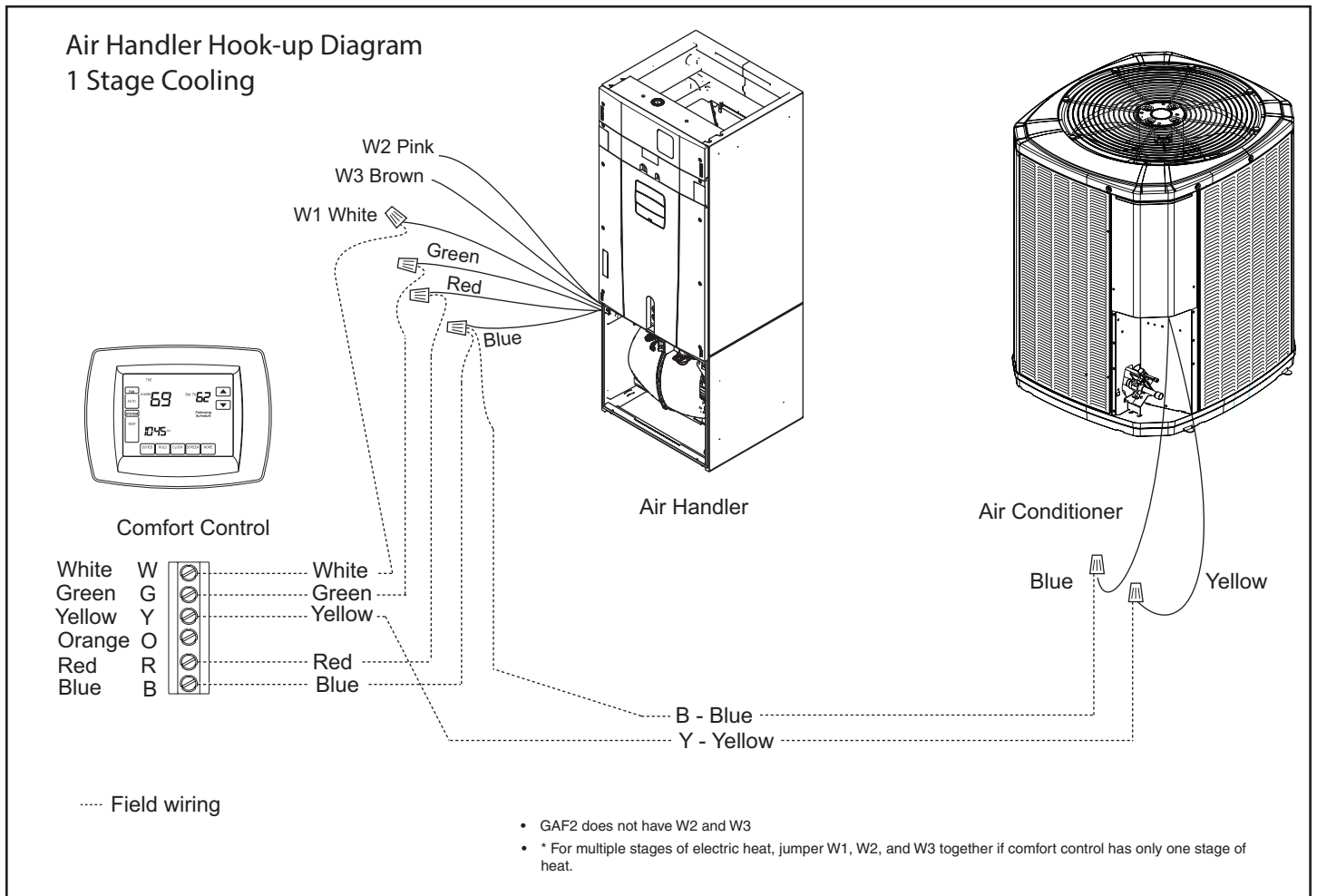



**TRANE®**

# Field Wiring

## GAF2 AND GAM2 50 HZ AIR HANDLERS WITH SINGLE SPEED HEAT PUMP

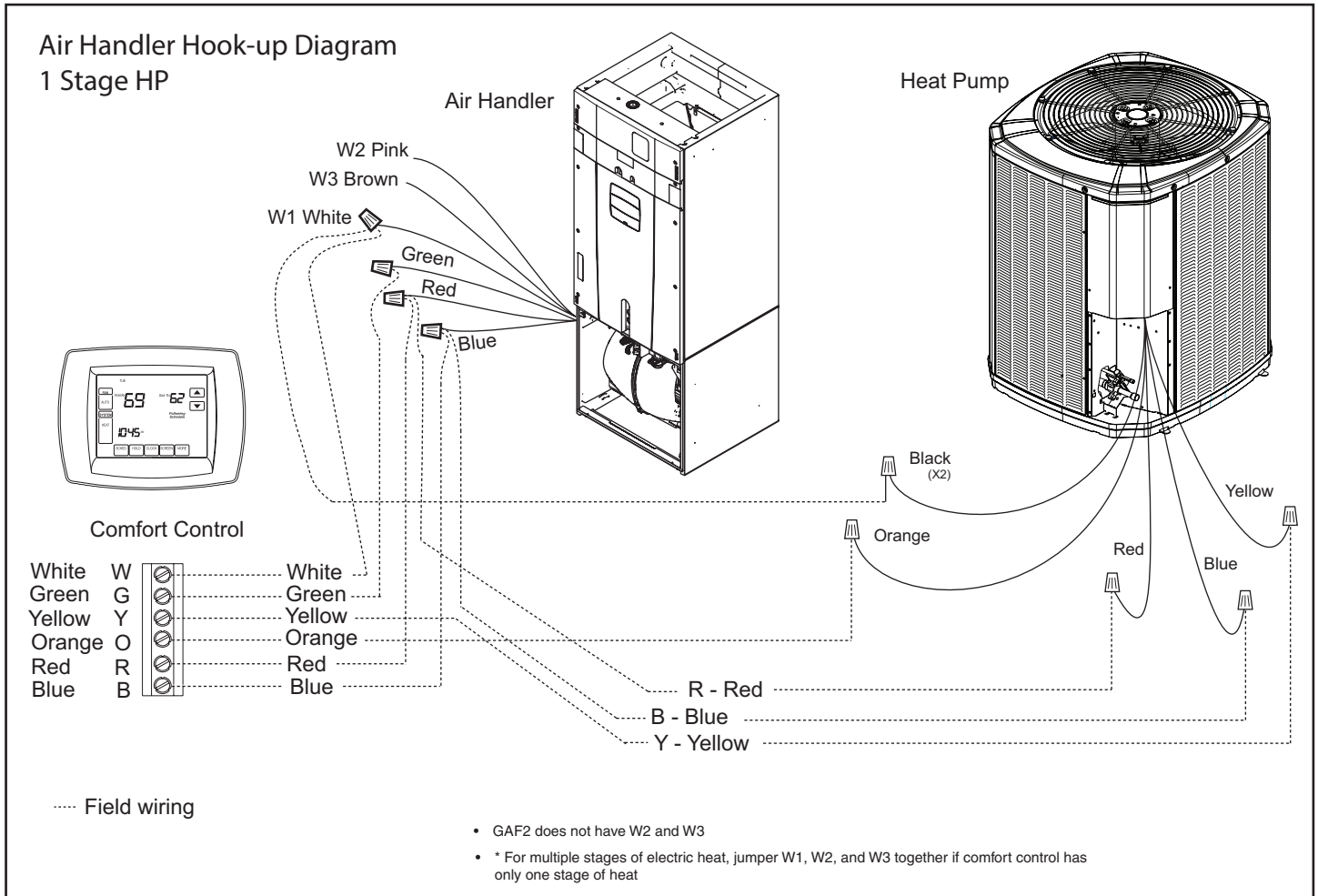



# GAM2 Convertibility

**\* Note: No internal modifications required for any position.  
Badge rotation will keep brand in correct position**

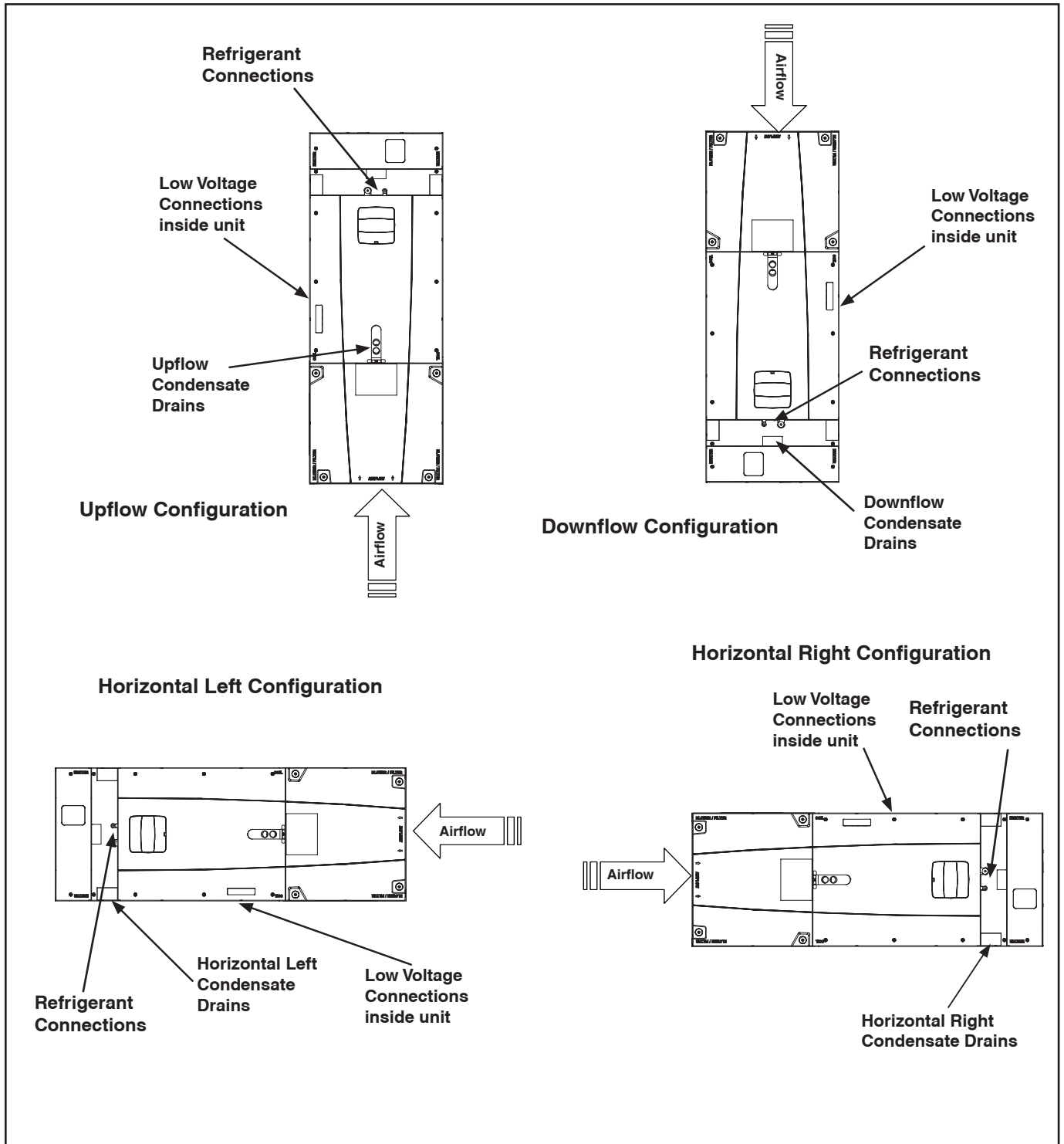



**TRANE®**

# GAF2 Convertibility

**\* Note: No internal modifications required for any position.  
Badge rotation will keep brand in correct position**

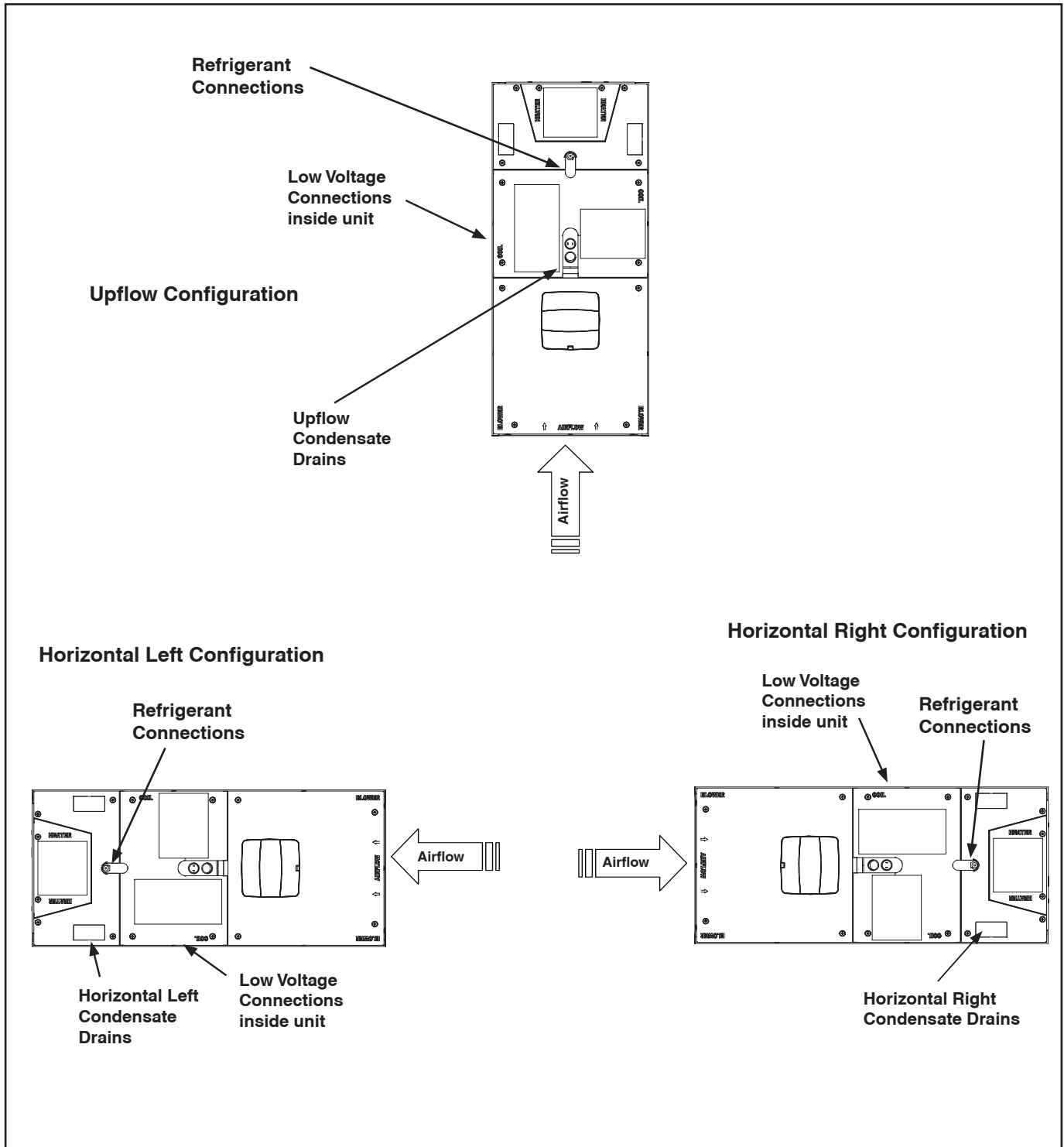

# GAM2 Dimensions

GAM2

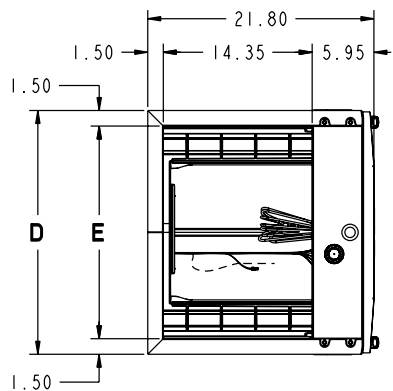

MINIMUM UNIT CLEARANCE TABLE		
	TO COMBUSTIBLE MATERIAL (REQUIRED)	SERVICE CLEARANCE (RECOMMENDED)
SIDES	0"	2"
FRONT	0"	21"
BACK	0"	0"
INLET DUCT	0"	
OUTLET DUCT	0"	

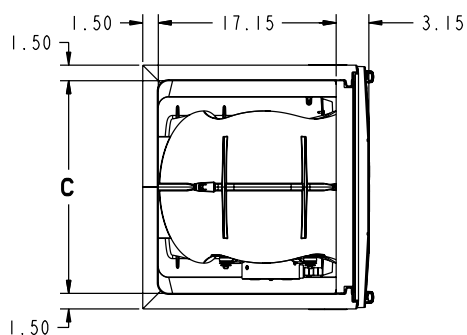
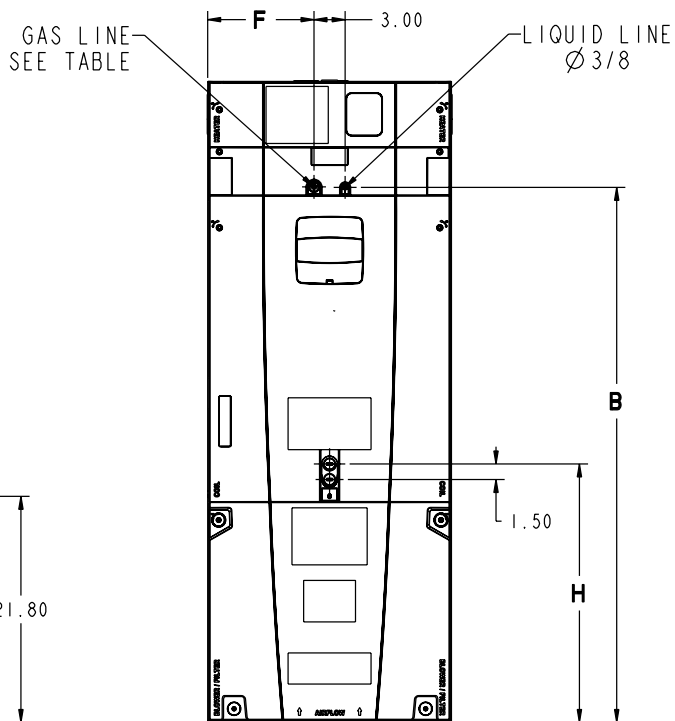
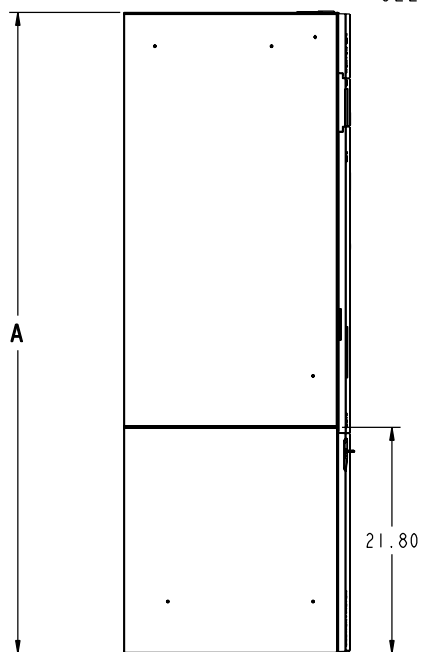

MODEL NO.	A	B	C	D	E	F	H	FLOW CONTROL	GAS LINE BRAZE
GAM2A0C48S4ASC	56.9	46.7	20.5	23.5	20.5	10.3	24.2	TXV	7/8
GAM2A0C60S5ASC	61.7	51.5	20.5	23.5	20.5	10.3	27.0	TXV	7/8



**TRANE®**

## GAM2 Dimensions

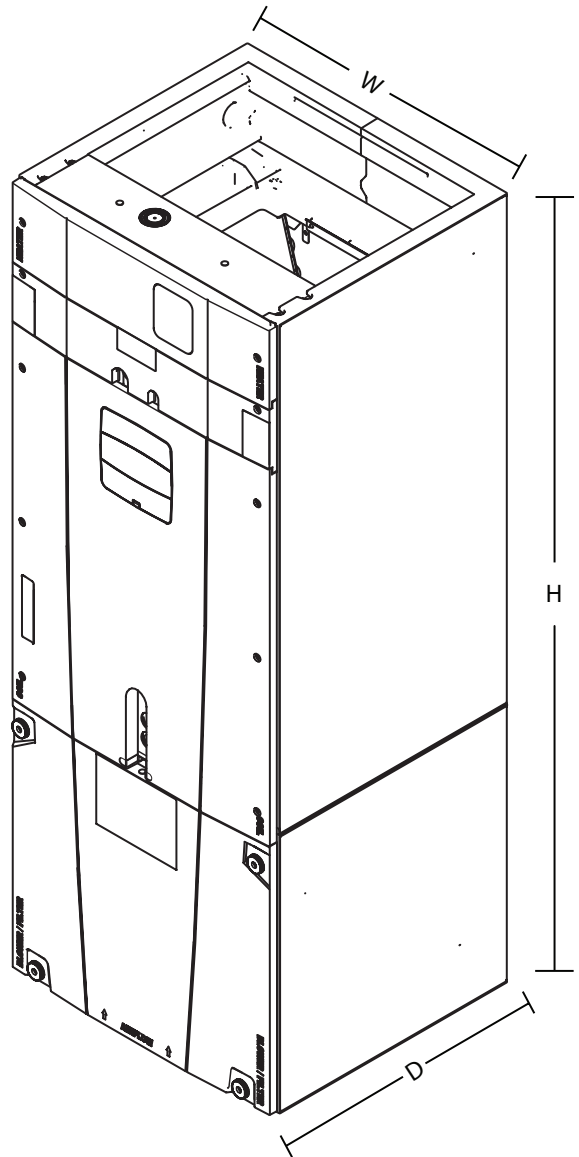

Model Number	H x D x W in.	**Blower Compartment in.	Unit Net Weight lbs.
GAM2A0C48S4ASC	56.9 x 23.5 x 21.8	22	143
GAM2A0C60S5ASC	61.7 x 23.5 x 21.8	22	159

\*\* Subtract from total height to get Coil and Heater compartment height.

GAM2 AIR HANDLERS ARE ALL  
TWO PIECE CABINETS.

# GAF2 Dimensions

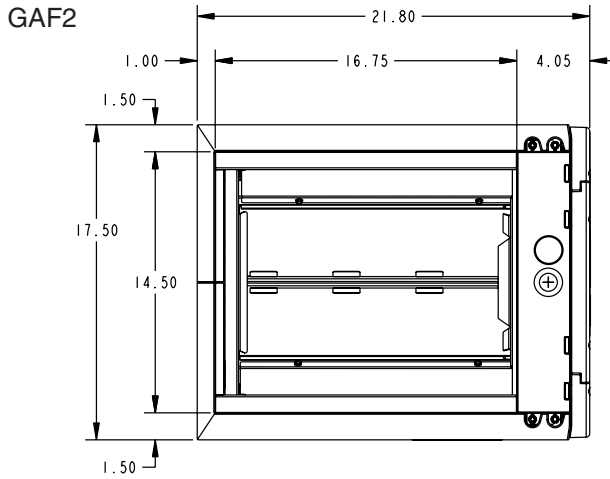

MINIMUM UNIT CLEARANCE TABLE		
	TO COMBUSTIBLE MATERIAL (REQUIRED)	SERVICE CLEARANCE (RECOMMENDED)
SIDES	0"	2"
FRONT	0"	21"
BACK	0"	0"
INLET DUCT	0"	N/A
OUTLET DUCT	0"	N/A

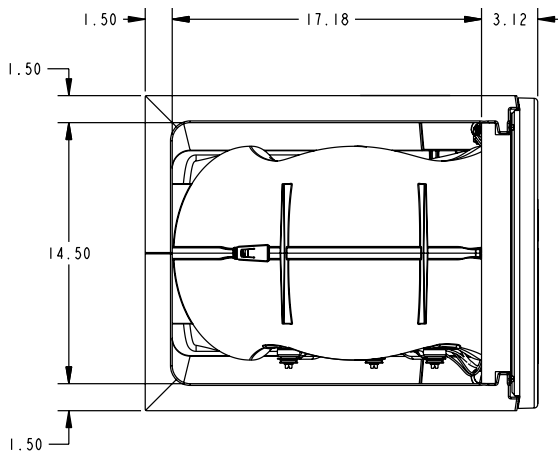
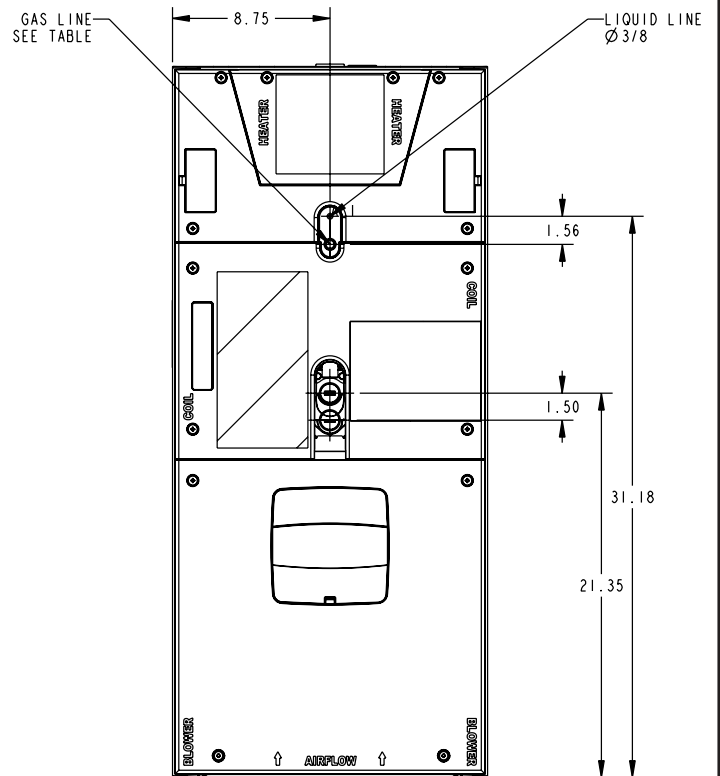
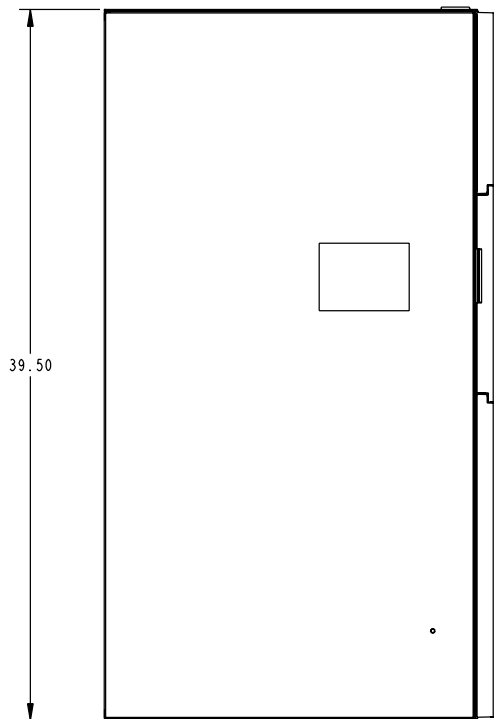

MODEL NO.	FLOW CONTROL	LIQUID LINE BRAZE	GAS LINE BRAZE
GAF 2A0A36S*	TXV	3/8	3/4



**TRANE®**

## **GAF2 Dimensions**

---

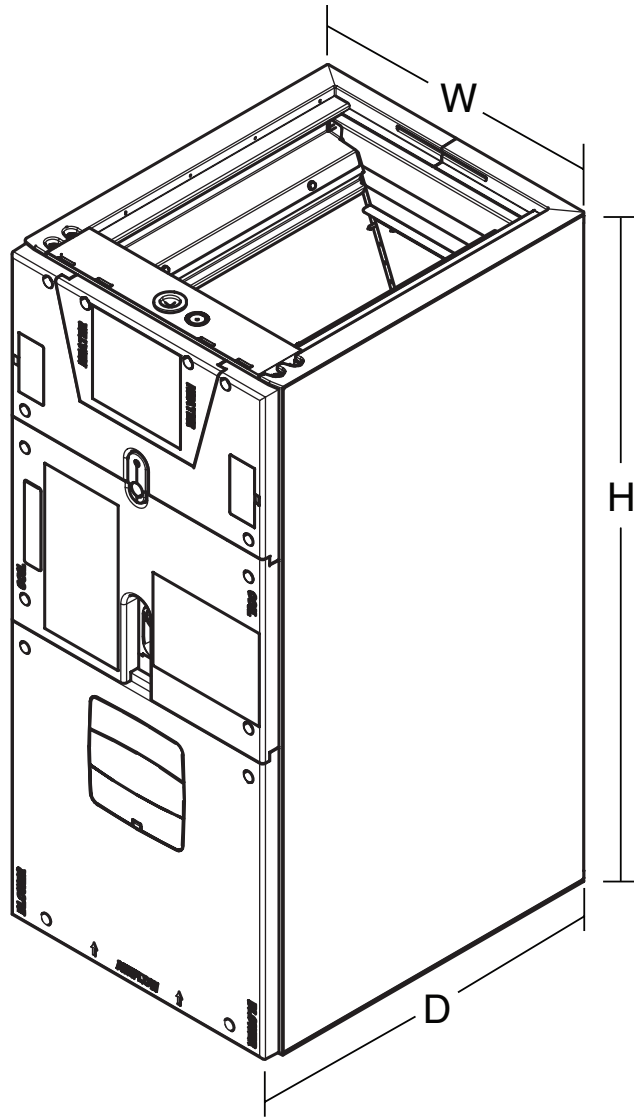

<b>Model Number</b>	<b>H x W x D in.</b>	<b>Unit Net Weight lbs.</b>
GAF2A0A36S3ASC	39 x 17.5 x 22	112

**GAF2 AIR HANDLERS ARE ALL ONE  
PIECE CABINETS.**





Trane - by Trane Technologies (NYSE: TT), a global climate innovator - creates comfortable, energy efficient indoor environments for commercial and residential applications. For more information, please visit [trane.com](http://trane.com) or [tranetechnologies.com](http://tranetechnologies.com).

---



The AHRI Certified mark indicates Trane U.S. Inc. participation in the AHRI Certification program. For verification of individual certified products, go to [ahridirectory.org](http://ahridirectory.org).

Trane has a policy of continuous data improvement and it reserves the right to change design and specifications without notice. We are committed to using environmentally conscious print practices.