

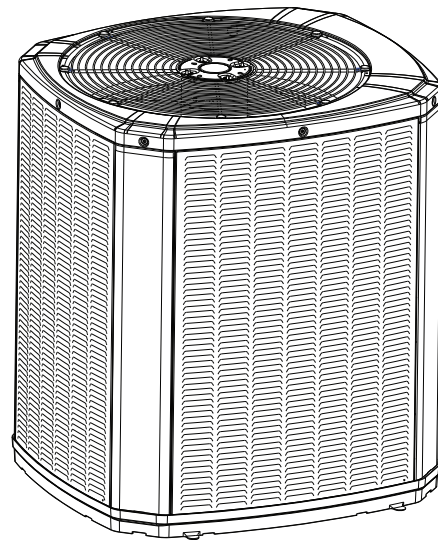

Installation, Operation, and Maintenance

Condensing Units

5TTA3036A3000A
5TTA3042A3000A
5TTA3048A3000A
5TTA3060A3000A
5TTA3036A4000A
5TTA3042A4000A
5TTA3048A4000A
5TTA3060A4000A



*Note: Graphics in this document are for representation only.
Actual model may differ in appearance.*

⚠ SAFETY WARNING

Only qualified personnel should install and service the equipment. The installation, starting up, and servicing of heating, ventilating, and air-conditioning equipment can be hazardous and requires specific knowledge and training. Improperly installed, adjusted or altered equipment by an unqualified person could result in death or serious injury. When working on the equipment, observe all precautions in the literature and on the tags, stickers, and labels that are attached to the equipment.



Introduction

Read this manual thoroughly before operating or servicing this unit.

This document is customer property and is to remain with this unit. Return to the service information pack upon completion of work.

Warnings, Cautions, and Notices

Safety advisories appear throughout this manual as required. Your personal safety and the proper operation of this machine depend upon the strict observance of these precautions.

The three types of advisories are defined as follows:



Indicates a potentially hazardous situation which, if not avoided, could result in death or serious injury.



Indicates a potentially hazardous situation which, if not avoided, could result in minor or moderate injury. It could also be used to alert against unsafe practices.



Indicates a situation that could result in equipment or property-damage only accidents.

Important Environmental Concerns

Scientific research has shown that certain man-made chemicals can affect the earth's naturally occurring stratospheric ozone layer when released to the atmosphere. In particular, several of the identified chemicals that may affect the ozone layer are refrigerants that contain Chlorine, Fluorine and Carbon (CFCs) and those containing Hydrogen, Chlorine, Fluorine and Carbon (HCFCs). Not all refrigerants containing these compounds have the same potential impact to the environment. Trane advocates the responsible handling of all refrigerants.

Important Responsible Refrigerant Practices

Trane believes that responsible refrigerant practices are important to the environment, our customers, and the air conditioning industry. All technicians who handle refrigerants must be certified according to local rules. For the USA, the Federal Clean Air Act (Section 608) sets forth the requirements for handling, reclaiming, recovering and recycling of certain refrigerants and the equipment that is used in these service procedures. In addition, some states or municipalities may have additional requirements that must also be adhered to for responsible management of refrigerants. Know the applicable laws and follow them.

⚠ WARNING

Proper Field Wiring and Grounding Required!

Failure to follow code could result in death or serious injury.

All field wiring **MUST** be performed by qualified personnel. Improperly installed and grounded field wiring poses **FIRE** and **ELECTROCUTION** hazards. To avoid these hazards, you **MUST** follow requirements for field wiring installation and grounding as described in NEC and your local/state/national electrical codes.

⚠ WARNING

Personal Protective Equipment (PPE) Required!

Failure to wear proper PPE for the job being undertaken could result in death or serious injury.

Technicians, in order to protect themselves from potential electrical, mechanical, and chemical hazards, **MUST** follow precautions in this manual and on the tags, stickers, and labels, as well as the instructions below:

- **Before installing/servicing this unit, technicians MUST put on all PPE required for the work being undertaken (Examples; cut resistant gloves/sleeves, butyl gloves, safety glasses, hard hat/bump cap, fall protection, electrical PPE and arc flash clothing). ALWAYS refer to appropriate Safety Data Sheets (SDS) and OSHA guidelines for proper PPE.**
- **When working with or around hazardous chemicals, ALWAYS refer to the appropriate SDS and OSHA/GHS (Global Harmonized System of Classification and Labelling of Chemicals) guidelines for information on allowable personal exposure levels, proper respiratory protection and handling instructions.**
- **If there is a risk of energized electrical contact, arc, or flash, technicians MUST put on all PPE in accordance with OSHA, NFPA 70E, or other country-specific requirements for arc flash protection, PRIOR to servicing the unit. NEVER PERFORM ANY SWITCHING, DISCONNECTING, OR VOLTAGE TESTING WITHOUT PROPER ELECTRICAL PPE AND ARC FLASH CLOTHING. ENSURE ELECTRICAL METERS AND EQUIPMENT ARE PROPERLY RATED FOR INTENDED VOLTAGE.**

⚠ WARNING**Follow EHS Policies!**

Failure to follow instructions below could result in death or serious injury.

- All Trane personnel must follow the company's Environmental, Health and Safety (EHS) policies when performing work such as hot work, electrical, fall protection, lockout/tagout, refrigerant handling, etc. Where local regulations are more stringent than these policies, those regulations supersede these policies.
- Non-Trane personnel should always follow local regulations.

⚠ WARNING**Cancer and Reproductive Harm!**

This product can expose you to chemicals, including lead, which are known to the State of California to cause cancer and birth defects or other reproductive harm. For more information go to www.P65Warnings.ca.gov.

⚠ WARNING**Safety Hazard!**

Failure to follow instructions below could result in death or serious injury or property damage.

This unit is not to be used by persons (including children) with reduced physical, sensory, or mental capabilities, or lack of experience and knowledge, unless they have been given supervision or instruction concerning the use of the appliance by a person responsible for their safety.

Do not allow children to play or climb on the unit or to clean or maintain the unit without supervision.

⚠ WARNING**Safety Hazard!**

Failure to follow instructions below could result in death or serious injury and/or property damage. Only qualified personnel should install and service the equipment. The installation, starting up, and servicing of heating, ventilating, and air-conditioning equipment can be hazardous and requires specific knowledge and training. Improperly installed, adjusted or altered equipment by an unqualified person could result in death or serious injury. When working on the equipment, observe all precautions in the literature and on the tags, stickers, and labels that are attached to the equipment.

⚠ WARNING**Risk of Fire — Flammable Refrigerant!**

Failure to follow instructions below could result in death or serious injury, and equipment damage.

- To be repaired only by trained service personnel.
- Do not puncture refrigerant tubing.
- Dispose of properly in accordance with federal or local regulations.

⚠ WARNING**Safety Hazard!**

Failure to follow instructions below could result in death or serious injury and/or property damage.

Only qualified personnel with adequate electrical and mechanical experience must repair the unit. The manufacturer or seller is not responsible for any interpretation or resulting liability.

⚠ WARNING**System Charge!**

Failure to follow instructions below could result in abrupt release of system charge and could result in serious injury or property damage.

When opening the suction and liquid line service valve, turn the valve stem counterclockwise only until the stem contacts the rolled edge. Do not apply torque.

⚠ WARNING**Ventilation Required!**

Failure to follow instructions below could result in death or serious injury or property damage.

Confirm the area is adequately ventilated before breaking into the system or conducting any hot work.

⚠ WARNING**Safety Hazard!**

Failure to follow instructions below could result in death or serious injury and equipment or property damage.

- Do not use any items other than those approved by the manufacturer for the defrosting or cleaning process.
- Do not pierce or burn.
- Be cautious that refrigerants may be odorless.



⚠ WARNING

Live Electrical Components!

Failure to follow all electrical safety precautions when exposed to live electrical components could result in death or serious injury.

When it is necessary to work with live electrical components, have a qualified licensed electrician or other individual who has been properly trained in handling live electrical components perform these tasks.

⚠ CAUTION

Brazed Joints!

Failure to follow instructions below could result in minor to moderate injury or equipment damage.

When using existing refrigerant lines, verify all joints are brazed and not soldered.

⚠ CAUTION

Hot Surface!

Failure to follow instructions below could result in minor to severe burns.

Do not touch top of compressor. It may be hot.

⚠ CAUTION

Unit Contains R-454B Refrigerant!

Failure to use proper service tools may result in equipment damage or personal injury.

Use only R-454B refrigerant and approved compressor oil.

Copyright

This document and the information in it are the property of Trane, and may not be used or reproduced in whole or in part without written permission. Trane reserves the right to revise this publication at any time, and to make changes to its content without obligation to notify any person of such revision or change.

Trademark

All trademarks referenced in this document are the trademarks of their respective owners.



Table of Contents

Pre-Installation	6	Low Voltage	16
General	6	Low Voltage Maximum Wire	
Operating Range.....	7	Length.....	16
Unit Location Considerations.....	7	Low Voltage Connection	
Unit Dimensions and Weight.....	7	Diagrams	16
Refrigerant Piping Limits	7	Mitigation Board Guidelines	17
Suggested Locations for Best		High Voltage	17
Reliability	8	High Voltage Power Supply.....	17
Coastal Considerations	8	High Voltage Disconnect Switch.....	18
Unit Preparation	8	High Voltage Ground	18
Prepare the Unit for Installation	8	System Start-Up.....	19
Setting the Unit.....	8	System Charge Adjustment	20
Pad Installation	8	Temperature Measurements	20
Refrigeration	9	Subcooling Charging in Cooling (Above	
Refrigerant Line Considerations.....	9	55°F Outdoor Temperature)	20
Refrigerant Line Routing	10	Weigh-in Method for Charging.....	24
Refrigerant Line Brazing	11	Checkout Procedures	25
Refrigerant Line Leak Check.....	13	Operational and Checkout Procedures	25
Evacuation and Servicing	14	Wiring Diagrams.....	26
Evacuate the Refrigerant Lines and Indoor		Pressure Curves.....	29
Coil.....	14	Refrigeration Circuits	31
Servicing	14	Refrigerant Detection System	32
Service Valves	14		
Open the Gas Service Valve First	14		
Open the Liquid Service Valve			
Second	15		
Electrical	16		



Pre-Installation

General

⚠ WARNING

Safety Hazard!

Failure to follow instructions below could result in death or serious injury and/or property damage. Only qualified personnel should install and service the equipment. The installation, starting up, and servicing of heating, ventilating, and air-conditioning equipment can be hazardous and requires specific knowledge and training. Improperly installed, adjusted or altered equipment by an unqualified person could result in death or serious injury. When working on the equipment, observe all precautions in the literature and on the tags, stickers, and labels that are attached to the equipment.

⚠ WARNING

Risk of Fire — Flammable Refrigerant!

Failure to follow instructions below could result in death or serious injury, and equipment damage.

- To be repaired only by trained service personnel.
- Do not puncture refrigerant tubing.
- Dispose of properly in accordance with federal or local regulations.

⚠ WARNING

Safety Hazard!

Failure to follow instructions below could result in death or serious injury and/or property damage. Only qualified personnel with adequate electrical and mechanical experience must repair the unit. The manufacturer or seller is not responsible for any interpretation or resulting liability.

⚠ CAUTION

Unit Contains R-454B Refrigerant!

Failure to use proper service tools may result in equipment damage or personal injury. Use only R-454B refrigerant and approved compressor oil.

⚠ WARNING

System Charge!

Failure to follow instructions below could result in abrupt release of system charge and could result in serious injury or property damage. When opening the suction and liquid line service valve, turn the valve stem counterclockwise only until the stem contacts the rolled edge. Do not apply torque.

⚠ WARNING

Ventilation Required!

Failure to follow instructions below could result in death or serious injury or property damage. Confirm the area is adequately ventilated before breaking into the system or conducting any hot work.

⚠ WARNING

Live Electrical Components!

Failure to follow all electrical safety precautions when exposed to live electrical components could result in death or serious injury.

When it is necessary to work with live electrical components, have a qualified licensed electrician or other individual who has been properly trained in handling live electrical components perform these tasks.

⚠ WARNING

Safety Hazard!

Failure to follow instructions below could result in death or serious injury or property damage. This unit is not to be used by persons (including children) with reduced physical, sensory, or mental capabilities, or lack of experience and knowledge, unless they have been given supervision or instruction concerning the use of the appliance by a person responsible for their safety. Do not allow children to play or climb on the unit or to clean or maintain the unit without supervision.

⚠ CAUTION

Brazed Joints!

Failure to follow instructions below could result in minor to moderate injury or equipment damage. When using existing refrigerant lines, verify all joints are brazed and not soldered.

⚠ CAUTION

Hot Surface!

Failure to follow instructions below could result in minor to severe burns. Do not touch top of compressor. It may be hot.

⚠ WARNING

Cancer and Reproductive Harm!

This product can expose you to chemicals, including lead, which are known to the State of California to cause cancer and birth defects or other reproductive harm. For more information go to www.P65Warnings.ca.gov.

⚠ WARNING

Ventilation Required!

Failure to follow instructions below could result in death or serious injury or property damage. Confirm the area is adequately ventilated before breaking into the system or conducting any hot work.

Note: The manufacturer recommends installing only approved matched indoor and outdoor systems. All of the manufacture's split systems are AHRI rated only with TXV/EEV indoor systems. Some of the benefits of installing approved matched indoor and outdoor split systems are maximum efficiency, optimum performance and the best overall system reliability.

Operating Range

Table 1. Operating range

Mode	Model	Operating Range
Cooling	3 – 5 Ton	55°F – 120°F

Unit Location Considerations

Unit Dimensions and Weight

Table 2. Unit dimensions and weight

Models	H x D x W (in.)	Weight ^(a) (lb)
5TTA3036A3	29 x 30 x 33	161
5TTA3042A3	37 x 30 x 33	184
5TTA3048A3	37 x 34 x 37	211
5TTA3060A3	37 x 34 x 37	211
5TTA3036A4	29 x 30 x 33	161
5TTA3042A4	37 x 30 x 33	184
5TTA3048A4	37 x 34 x 37	211
5TTA3060A4	37 x 34 x 37	211

^(a) Weight values are estimated uncrated.

When mounting the outdoor unit on a roof, be sure the roof will support the unit's weight.

Properly selected isolation is recommended to alleviate sound or vibration transmission to the building structure.

Figure 1. Unit dimensions

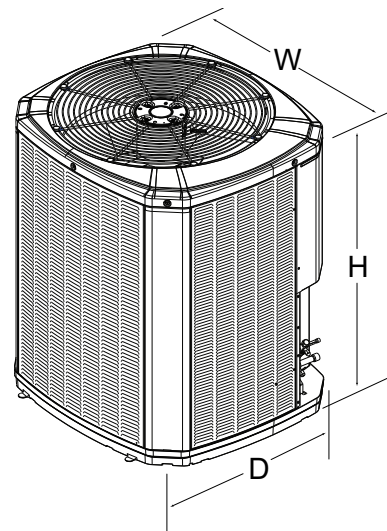

Refrigerant Piping Limits

- The maximum TOTAL length of refrigerant lines from outdoor to indoor unit should NOT exceed 150 feet (including lift).
- The maximum vertical change should not exceed 50 feet.
- Service valve connection diameters are shown in .

Note: For other line lengths, see the Refrigerant Piping — Application Guide, (SS-APG006-EN) or Refrigerant Piping Software Program.*

Figure 2. Refrigerant total line length limit

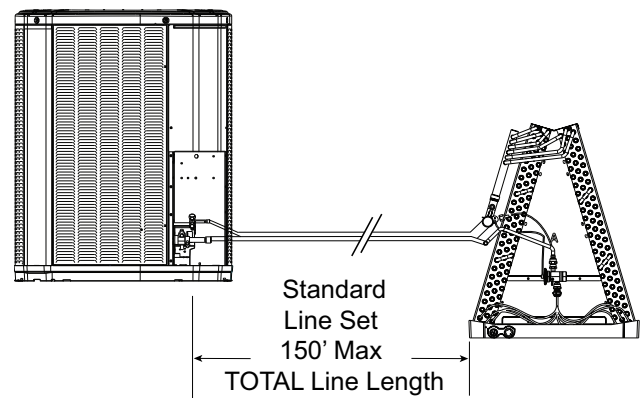

Figure 3. Refrigerant piping vertical change limit

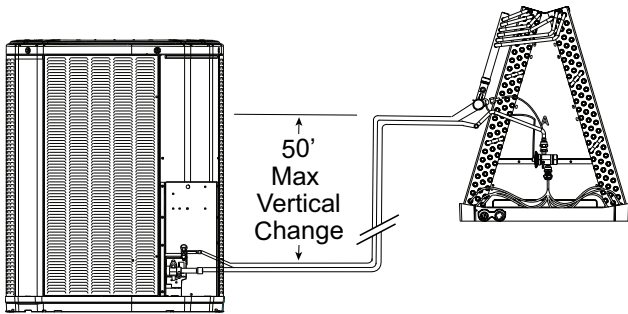
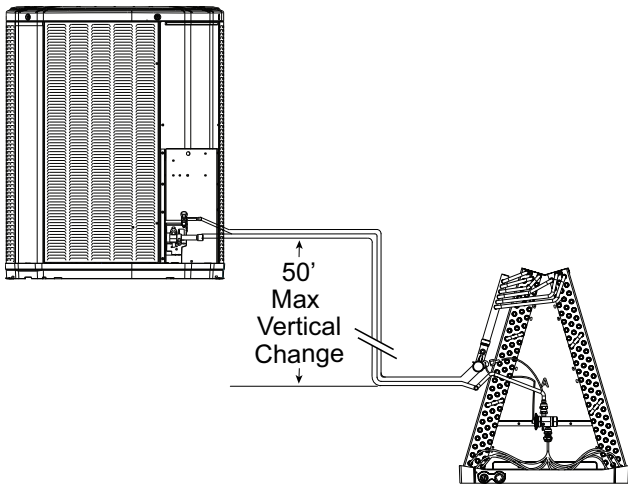

Figure 4. Refrigerant piping vertical change limit



Suggested Locations for Best Reliability

- Ensure the top discharge area is unrestricted for at least five (5) feet above the unit.
- Three (3) feet clearance must be provided in front of the control box (access panels) and any other side requiring service.
- Do not locate close to bedrooms as operational sounds may be objectionable.
- Position the outdoor unit a minimum of 12-inch from any wall or surrounding shrubbery to ensure adequate airflow.
- Outdoor unit location must be far enough away from any structure to prevent excess roof runoff water from pouring directly on the unit.
- Please reference Indoor Unit Installer's Guide for correct specifications on indoor unit install.

Figure 5. Suggested locations for best reliability

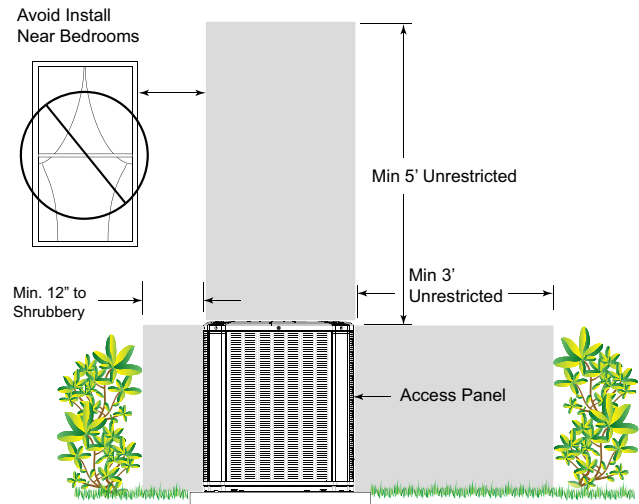

Coastal Considerations

If installed within one mile of salt water, including seacoasts and inland waterways, models without factory supplied Seacoast Salt Shields require the addition of BAYSEAC001 (Seacoast Kit) at installation time.

Unit Preparation

Prepare the Unit for Installation

1. Check for damage and report promptly to the carrier any damage found to the unit.
2. To remove the unit from the pallet, remove tabs by cutting with a sharp tool.

Setting the Unit

Pad Installation

When installing the unit on a support pad, such as a concrete slab, consider the following:

- The pad should be at least 1-inch larger than the unit on all sides.
- The pad must be separate from any structure.
- The pad must be level.
- The pad should be high enough above grade to allow for drainage.
- The pad location must comply with National, State, and Local codes.

Refrigeration

Refrigerant Line Considerations

Table 3. Refrigerant line and service valve connection sizes

Model	Rated Line Sizes (in.)		Alternate Line Sizes (in.)	Service Valve Connection Sizes (in.)	
	Vapor Line	Liquid Line	Liquid Line	Vapor Line Connection	Liquid Line Connection
5TTA3036A3	3/4	5/16	3/8	3/4	5/16
5TTA3042A3	7/8	5/16	3/8	7/8	5/16
5TTA3048A3	7/8	5/16	3/8	7/8	5/16
5TTA3060A3	7/8	5/16	3/8	7/8	5/16
5TTA3036A4	3/4	5/16	3/8	3/4	5/16
5TTA3042A4	7/8	5/16	3/8	7/8	5/16
5TTA3048A4	7/8	5/16	3/8	7/8	5/16
5TTA3060A4	7/8	5/16	3/8	7/8	5/16

Factory Charge

The outdoor condensing units are factory charged with the system charge required for the outdoor condensing unit, fifteen (15) ft. of tested connecting line, and the nominal rated indoor evaporative coil match. Always verify proper system charge via subcooling (TXV/EEV) or superheat (fixed orifice) per the unit nameplate.

Required Refrigerant Line Length

Determine required line length and lift.

Total Line Length = _____ Ft.

Total Vertical Change (lift) = _____ Ft.

Figure 6. Required refrigerant line length

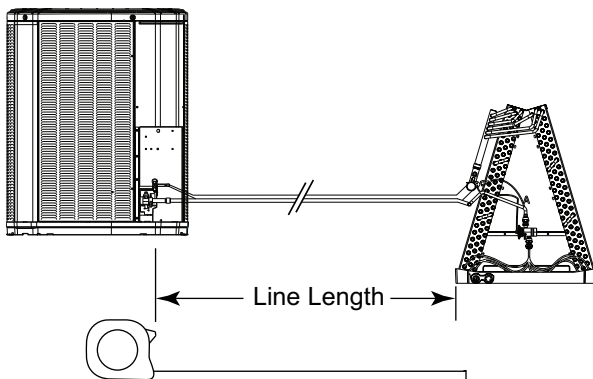

Refrigerant Line Insulation

Important: The vapor line must always be insulated. Do not allow the Liquid Line and Vapor Line to come in direct (metal to metal) contact.

Figure 7. Refrigerant line insulation

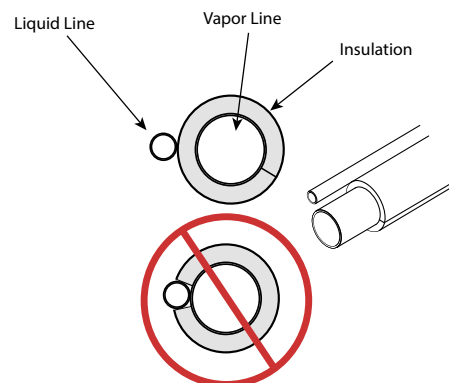

Reuse Existing Refrigerant Lines

⚠ CAUTION

Brazed Joints!

Failure to follow instructions below could result in minor to moderate injury or equipment damage. When using existing refrigerant lines, verify all joints are brazed and not soldered.

For retrofit applications, where the existing refrigerant lines will be used, the following precautions should be taken:

- Verify that the indoor evaporator coil and refrigerant lines are the correct size.
- Verify that the refrigerant lines are free of leaks, acid, and oil.

Figure 8. Reuse existing refrigerant lines

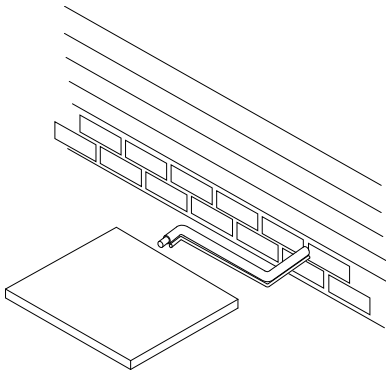

Comply with national, state, and local codes when isolating line sets from joists, rafters, walls, or other structural elements.

For example:

- When the refrigerant lines need to be fastened to floor joists or other framing in a structure, use isolation type hangers.
- Isolation hangers should also be used when refrigerant lines are run in stud spaces or enclosed ceilings.
- Where the refrigerant lines run through a wall or sill, they should be insulated and isolated.
- Isolate the lines from all ductwork.
- Minimize the number of 90° turns.

Refrigerant Line Routing

Precautions

Important: Take precautions to prevent noise within the building structure due to vibration transmission from the refrigerant lines.

Secure the vapor line from joists using isolators every 8 feet. Secure the liquid line directly to the vapor line using tape, wire, or other appropriate method every 8 feet.

Figure 9. Isolation from joist/rafter

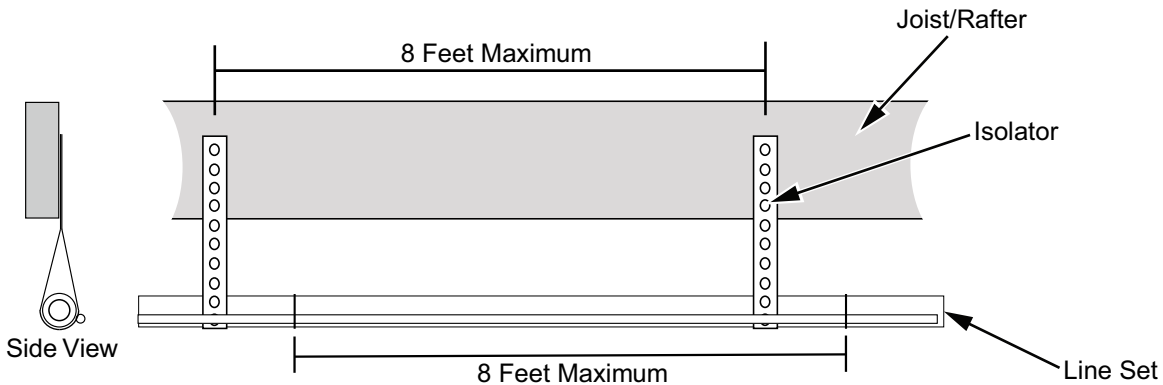

Secure the vapor line using isolators every 8 feet. Secure the liquid line directly to the vapor line using tape, wire, or other appropriate method every 8 feet.

Figure 10. Isolation in wall spaces

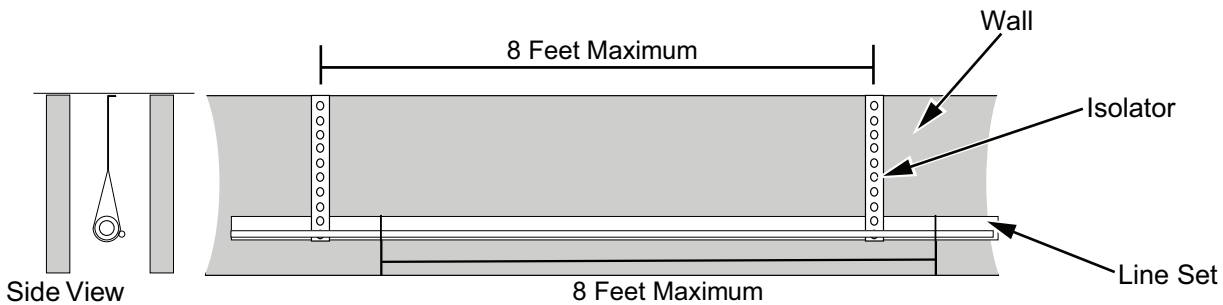

Figure 11. Isolation through wall

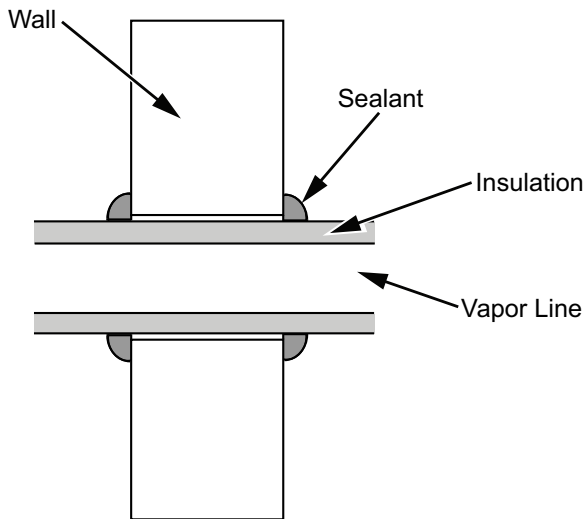
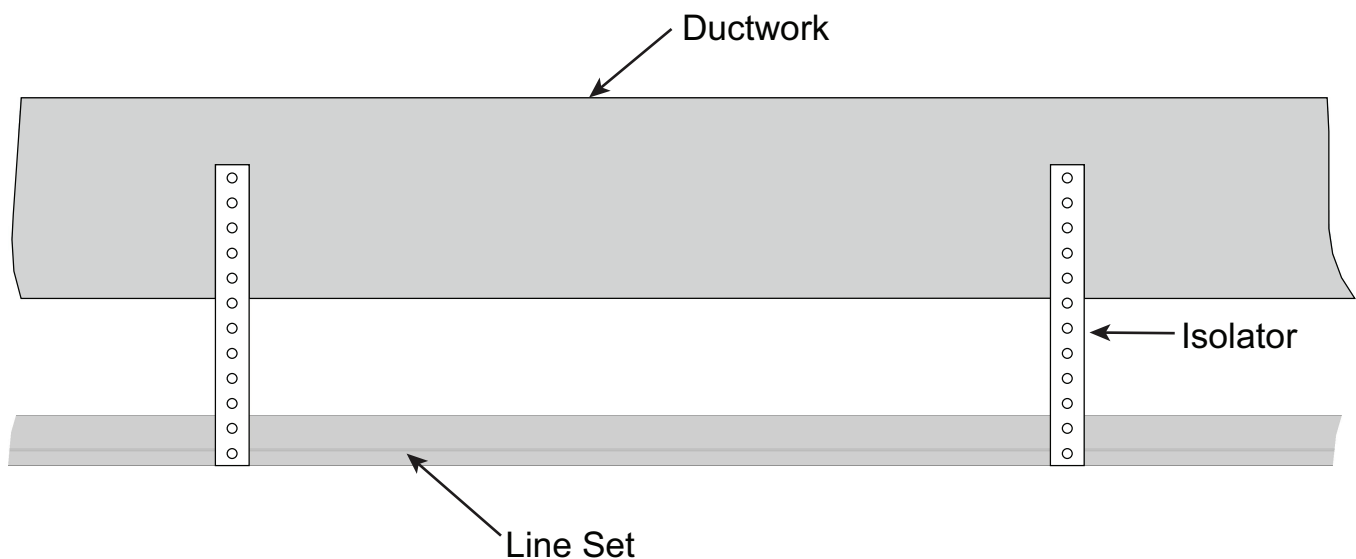

Figure 12. Incorrect lineset installation



Do not hang line sets from ductwork.

Refrigerant Line Brazing

Braze the Refrigerant Lines

1. Remove caps or plugs. Use a deburring tool to deburr the pipe ends. Clean both internal and external surfaces of the tubing using an emery cloth.
2. Remove the pressure tap cap and valve cores from both service valves.
3. Purge the refrigerant lines and indoor coil with dry nitrogen.

Note: A2L equipment shall have red marked service ports and pipes through which refrigerant is serviced.

4. Wrap a wet rag around the valve body to avoid heat damage and continue the dry nitrogen purge.

- a. Braze the refrigerant lines to the service valves.
- b. For units shipped with a field-installed external drier, check liquid line filter driers directional flow arrow to confirm correct direction of refrigeration flow (away from outdoor unit and toward evaporator coil) as illustrated. Braze the filter drier to the Liquid Line.
- c. Continue the dry nitrogen purge. Do not remove the wet rag until all brazing is completed.

Important: Remove the wet rag before stopping the dry nitrogen purge.

Pre-Installation

Notes:

- Install drier in Liquid Line.
- Precautions should be taken to avoid heat damage to basepan during brazing. It is recommended to keep the flame directly off of the basepan.

5. Replace the pressure tap valve cores and plastic tabs after the service valves have cooled.

Figure 13. Removal of caps or plugs from pipe ends

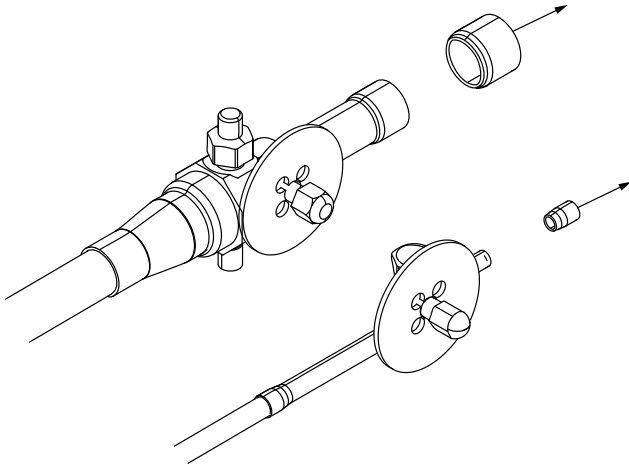

Figure 14. Removal of pressure cap and valve cores from service valves

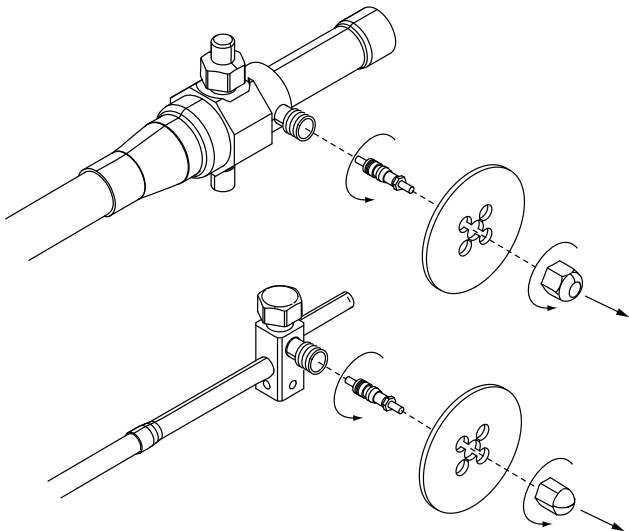

Figure 15. Purging of refrigerant lines

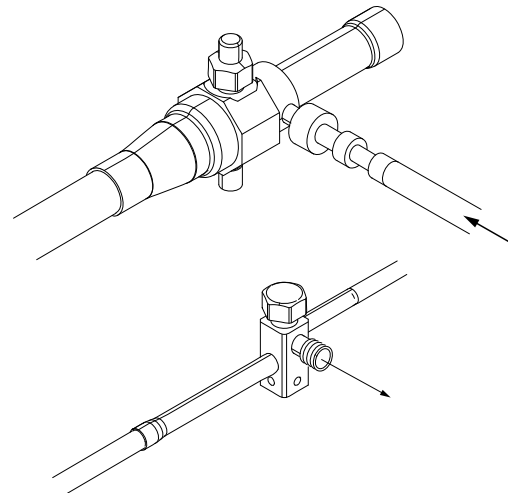

Figure 16. Wrapping of wet rag

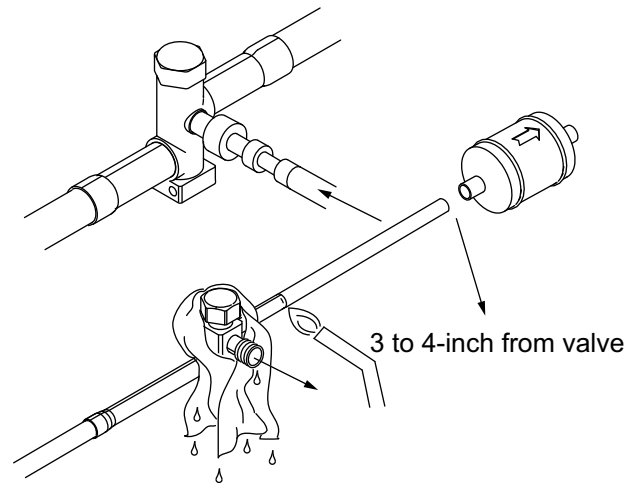
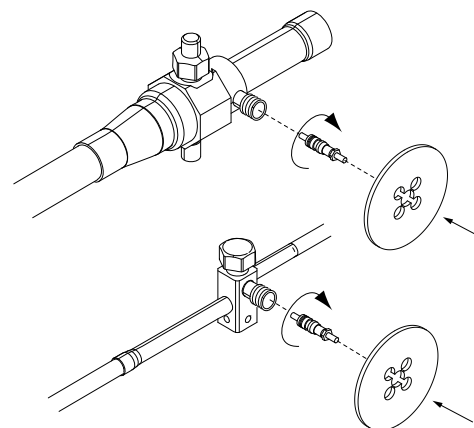

Figure 17. Re-installation of pressure valve cores and plastic tabs



Refrigerant Line Leak Check

Check for Leaks

After completion of field piping for split systems, the field pipework shall be pressure tested with nitrogen and then vacuum tested prior to refrigerant charging.

Important:

1. *Under no circumstances shall potential sources of ignition be used in the searching for or detection of refrigerant leaks.*
2. *The following leak detection methods are deemed acceptable for all refrigerant systems:*
 - *Electronic leak detectors calibrated for R-454B (with a sensitivity of 5 grams/year).*
 - *Bubble method.*
3. *The outdoor unit should not be tested higher than 450 psig for servicing or component replacement. The indoor unit and linesets should be tested to the max pressure specified on the outdoor or indoor unit nameplate. The service valves should be closed when pressure testing the evaporator coil and linesets to separate the outdoor unit from the indoor unit.*

1. Final Pressure Check:

Isolate the outdoor unit from the evaporator coil and linesets using the service valves. Pressurize the evaporator coil and linesets to the max pressure specified on the outdoor or indoor unit nameplate for a minimum of 60 minutes. Do not add additional refrigerant or test gas after reaching the evaporator coil specified pressure. The system should show no loss of pressure once pressurized. Once the pressure test is complete follow the steps for evacuation.

2. Preliminary Pressure Check (*Optional):

Pressurize the refrigerant lines and evaporator coil to 150 psig using dry nitrogen. Check for leaks by using a soapy solution or bubbles at each brazed location. Remove pressure and repair any leaks before continuing.

Figure 18. Refrigerant line leak check

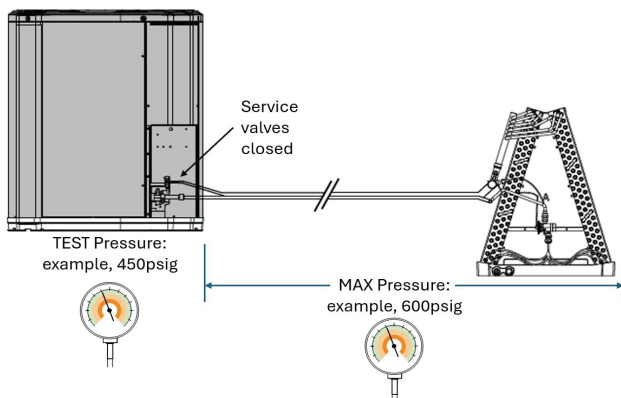

Evacuation and Servicing

Evacuate the Refrigerant Lines and Indoor Coil

Important: Do not open the service valves until the refrigerant lines and indoor coil leak check and evacuation are complete.

1. Evacuate until the micron gauge reads no higher than 350 microns, then close the valve to the vacuum pump.

Figure 19. Observe micron gauge reading

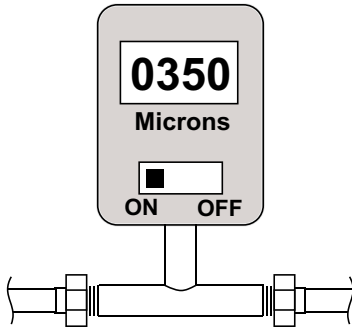

2. Observe the micron gauge. Evacuation is complete if the micron gauge does not rise above 500 microns in one minute.

Figure 20. Stop watch



3. Once evacuation is complete, clear the vacuum pump and micron gauge, then close the valve on the manifold gauge set.

Servicing

- If repairs must be made after system is charged, properly and safely remove or isolate refrigerant and purge the section of the system needing repair with nitrogen gas or oxygen-free nitrogen prior to opening the circuit.
- The Refrigerant charge shall be recovered into the correctly marked recovery cylinders.

- Ensure that the outlet for the vacuum pump is not close to any potential ignition sources and the ventilation is available.
- Prior to recharging the system, it shall be pressure-tested with the appropriate purging gas. The system shall be leak-tested on completion of charging but prior to commissioning. A follow up leak test shall be carried out prior to leaving the site.
- Ensure that only appropriate refrigerant recovery cylinders are employed. Ensure that the correct number of cylinders for holding the total system charge is available. Only use cylinders designated for the recovered refrigerant and labelled for the refrigerant. Cylinders shall be complete with pressure-relief valve and associated shut-off valves in good working order.
- A set of calibrated weighing scales shall be available and in good working order. Hoses shall be complete with leak-free disconnect couplings and in good condition. Ensure any associated electrical components are sealed.
- The recovered refrigerant shall be returned to the refrigerant supplier in the correct recovery cylinder. Do not mix refrigerants.
- If compressors or compressor oils are to be removed, ensure that they have been evacuated to an acceptable level to make certain that A2L refrigerant does not remain within the lubricant.

Service Valves

Open the Gas Service Valve First

Important: Leak check and evacuation must be completed before opening the service valves.

Note: Do not vent refrigerant gases into the atmosphere.

1. Remove valve stem cap.
2. Using an adjustable wrench, turn valve stem 1/4 turn counterclockwise to the fully open position.
3. Replace the valve stem cap to prevent leaks. Tighten finger tight plus an additional 1/6 turn.

Note: Service valves may be ball or angle style.

Figure 21. Gas service valve

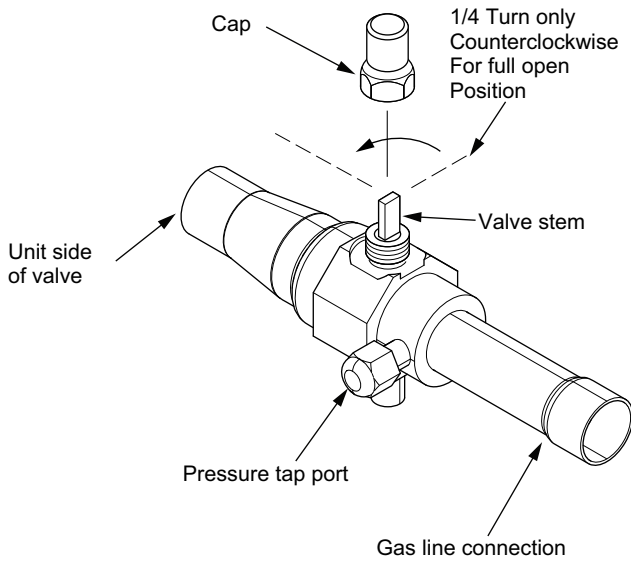

Important: Leak check and evacuation must be completed before opening the service valves.

1. Remove service valve cap.
2. Fully insert 3/16-inch hex wrench into the stem and back out counterclockwise until valve stem just touches the rolled edge (approximately five (5) turns).
3. Replace the valve cap to prevent leaks. Tighten finger tight plus an additional 1/6 turn.

Figure 22. Liquid service valve

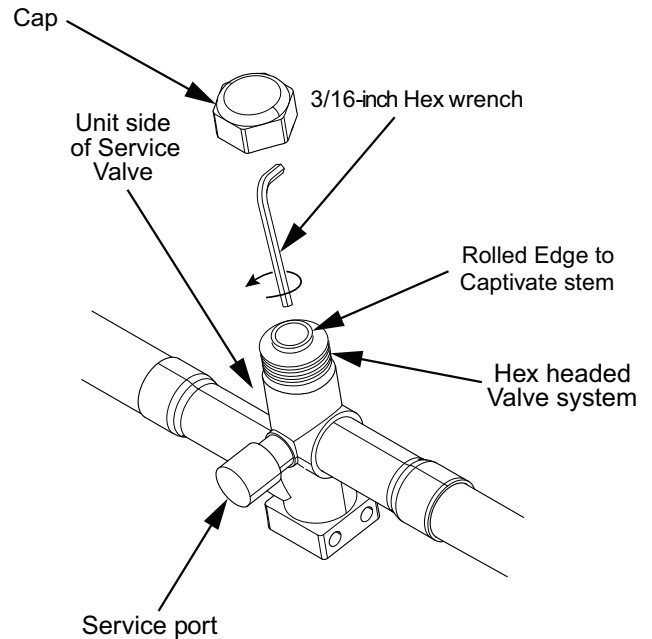

Open the Liquid Service Valve Second

⚠ WARNING

System Charge!

Failure to follow instructions below could result in abrupt release of system charge and could result in serious injury or property damage.

When opening the suction and liquid line service valve, turn the valve stem counterclockwise only until the stem contacts the rolled edge. Do not apply torque.



Electrical

Low Voltage

Low Voltage Maximum Wire Length

The following table defines the maximum total length of low voltage wiring from the outdoor unit, to the indoor unit, and to the thermostat.

Table 4. Low voltage maximum wire length

24 Volts	
Wire Size	Max. Wire Length (ft.)
18 AWG	150
16 AWG	225
14 AWG	300

Low Voltage Connection Diagrams

Figure 23. Single-stage AC with 5TEM4/6/C or 5TAM5/X

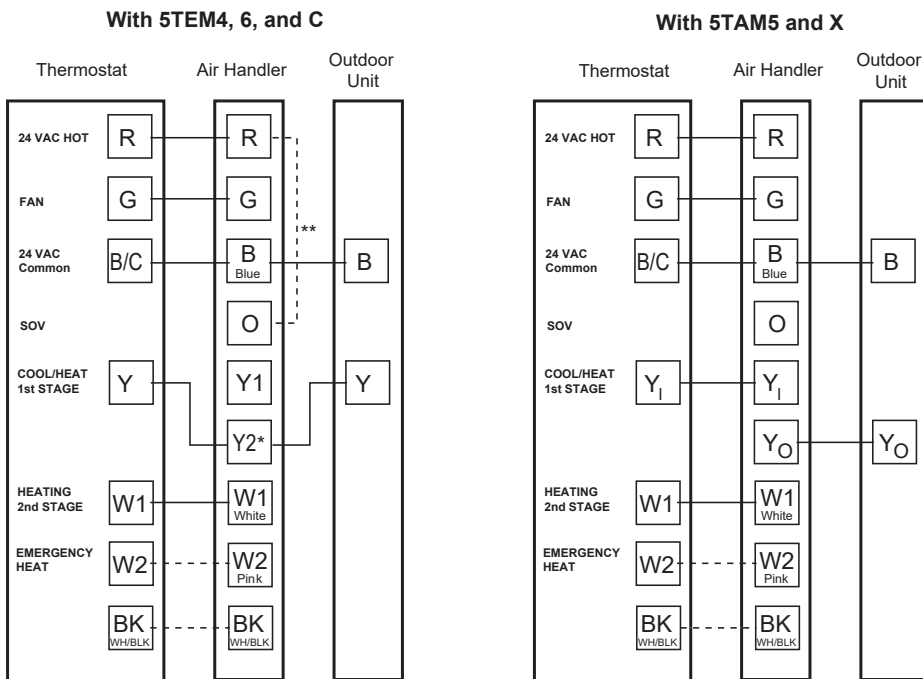

- Units with pigtailed require wirenuts for connections. Cap all unused wires.
- In AC systems for multiple stages of electric heat, jumper W1 and W2 together if comfort control has only one stage of heat.
- TEM3/4 - Bypass air handler and connect Y from comfort control directly to OD unit
- **TEM6 only - When using a BK enabled comfort control, cut BK jumper and bypass Y1 and Y2 at the air handler. Connect BK from comfort control to BK of the air handler
- TAM4 only - Wire as shown, no BK is available
- TAM7 only - When using a BK enabled comfort control, cut BK jumper on the AFC and connect BK from comfort control to BK of the air handler.

Figure 24. Single-stage AC with furnace or variable speed furnace

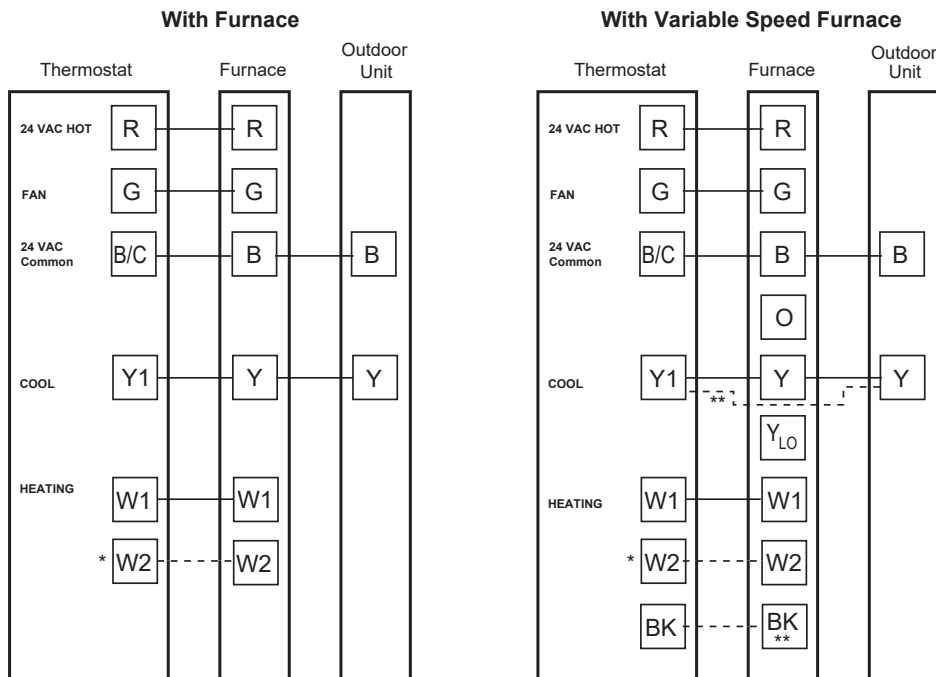

- Units with pigtails require wirenuts for connections. Cap all unused wires.
- In AC systems for multiple stages of heat, jumper W1 and W2 together if comfort control has only one stage of heat.

*If equipped with second-stage heat.

**When using a BK enabled comfort control, cut BK jumper and bypass Y and YLo at the furnace. Connect BK from comfort control to BK of the furnace.

Mitigation Board Guidelines

- The approved ID/OD combination will provide sufficient safe ventilation in case of a leak.
- Refer to Indoor Unit Installer's Guide for correct specifications on indoor unit install.
- All systems require mitigation boards so an altitude adjustment factor may be required.
- Mitigation Control Board needs to be included in an A2L System.

The high voltage power supply must agree with the equipment nameplate.

Check that cabling will not be subject to wear, corrosion, excessive pressure, vibration, sharp edges or any other adverse environmental effects.

Power wiring must comply with national, state, and local codes.

Follow instructions on unit wiring diagram located on the inside of the control box cover.

High Voltage

High Voltage Power Supply

⚠ WARNING

Live Electrical Components!

Failure to follow all electrical safety precautions when exposed to live electrical components could result in death or serious injury.

When it is necessary to work with live electrical components, have a qualified licensed electrician or other individual who has been properly trained in handling live electrical components perform these tasks.



Electrical

Figure 25. Nameplate location

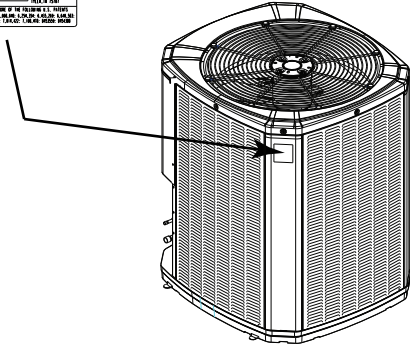
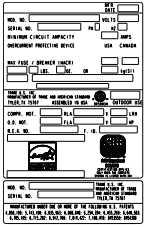

High Voltage Disconnect Switch

Install a separate disconnect switch at the outdoor unit.

For high voltage connections, flexible electrical conduct is recommended whenever vibration transmission may create a noise problem within the structure.

Figure 26. High voltage disconnect switch

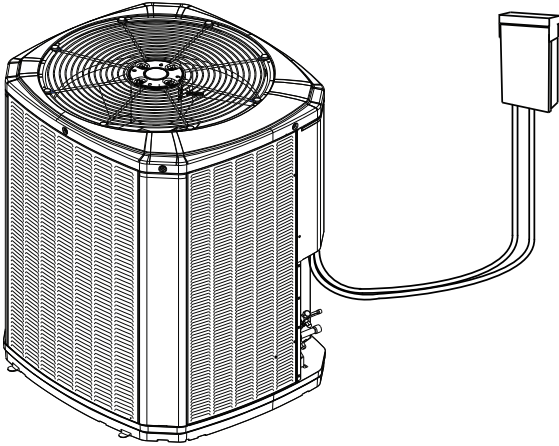

High Voltage Ground

Ground the outdoor unit per National, State, and Local code requirements.

⚠ WARNING

Safety Hazard!

Failure to follow instructions below could result in death or serious injury, and property damage. Confirm the cabling is protected from wear and tear, corrosion, excessive pressure, vibration, sharp edges, and any other adverse environmental effects.



System Start-Up

1. Confirm that chapters Refrigerant Line Brazing through Electrical – High Voltage have been completed.
2. Turn on the disconnect(s) to apply power to the indoor and outdoor units.
3. Wait one hour before starting the unit if the compressor crankcase heater accessory is used and the outdoor ambient is below 70° F.
4. Set system thermostat to ON.



System Charge Adjustment

Temperature Measurements

Note: Systems can be rated with TXV, EEV or Piston.
Ensure charging method is correct.

Important:

1. Installer must mark/write the total refrigerant charge on the OD unit label after adjusting for indoor coil and lineset. Technicians must have their refrigerant cylinder on a scale during the charging procedure and measure how much additional refrigerant is put in the system (additional over the factory charge). The additional charge must be recorded on the label provided on the outdoor unit as well as the resulting total system charge.
2. Standard service trucks and vans may not carry more than six 25# cylinders (< 220 lb of A2L refrigerant total).
3. A2L approved equipment required for leak detection, charge and recovery.
4. Ensure that contamination of different refrigerants does not occur when using charging equipment.
5. A set of calibrated weighing scales shall be available and in good working order. Hoses shall be complete with leak-free disconnect couplings and in good condition. Ensure any associated electrical components are sealed.

Check the outdoor temperatures.

Subcooling (in cooling mode) is the only recommended* method of charging above 55° F ambient outdoor temperature.

Note: For Superheat (In Cooling Mode), see the [Table 7, p. 23](#).

Weigh-In Method can be used for initial installation, or system replacement when power is not available or when the desired temperatures for the standard charging method are outside normal bounds. See “[Weigh-in Method for Charging](#),” p. 24.

For best results the indoor temperature should be kept between 70° F to 80° F.

Note: It is important to return in the spring or summer to accurately charge the system in the cooling mode when outdoor ambient temperature is above 55° F.

Subcooling Charging in Cooling (Above 55°F Outdoor Temperature)

1. Use the refrigerant line total length and lift measurements from “[Required Refrigerant Line Length](#),” p. 9.

Total Line Length = _____ Ft.

Vertical Change (Lift) = _____ Ft.

Figure 27. Refrigerant line total length and lift

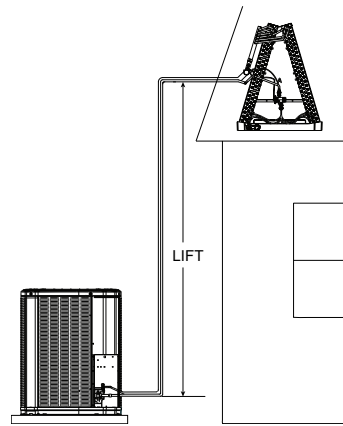

2. Determine the final subcooling target using total line length and lift measured in [Step 1](#). and the charts below.

Figure 28. Subcool charging corrections – models 036 and 042

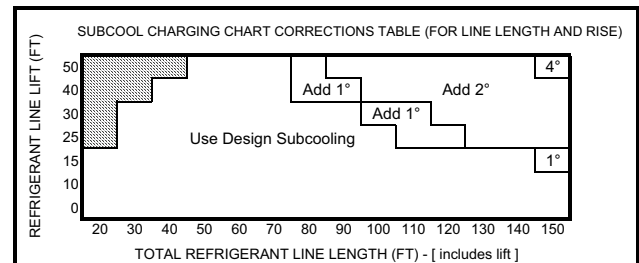
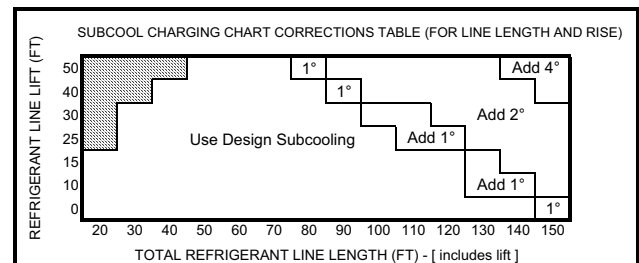

Figure 29. Subcool charging corrections – models 048 and 060



Design Subcooling Value = _____ °F

(from nameplate or Service Facts)

Subcooling Correction = _____ °F

Final Subcooling Value = _____ °F

3. Stabilize the system by operating for a minimum of 20 minutes whenever charge is removed or added before accurate measurements can be made.
4. Measure the liquid line temperature and pressure at the outdoor unit's service valve.

Measured Liquid Line Temperature = _____ °F

Liquid Gage Pressure = _____ PSI

Final Subcooling Target = _____ °F

5. Use the final subcooling target, refrigerant temperature and pressure from [Step 4.](#), to determine the proper liquid gage pressure using [Table 5, p. 21.](#)

Example: Assume a 12°F Final Subcooling Target and liquid temperature of 90°F.

- a. Locate 12°F Final Subcooling in [Table 5, p. 21.](#)
- b. Locate the Liquid Temperature (90°F) in the left column.
- c. The Liquid Gage Pressure should be approximately 327 PSI. (This is the shown as the intersection of the Final Subcooling column and the Liquid Temperature row).

Figure 30. Charging the unit

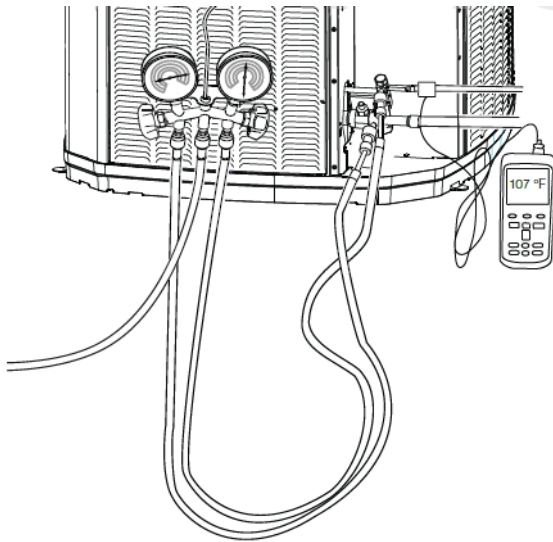

Table 5. R-454B refrigerant charging chart

Liquid Temp(°F)	Design Subcooling (°F)						
	8	9	10	11	12	13	14
	Liquid Gauge Pressure (PSI)						
55	170	172	175	178	181	184	187
60	184	187	190	194	197	200	203
65	200	203	206	210	213	217	220

Table 5. R-454B refrigerant charging chart (continued)

Liquid Temp(°F)	Design Subcooling (°F)						
	8	9	10	11	12	13	14
	Liquid Gauge Pressure (PSI)						
70	217	220	223	227	230	234	238
75	234	238	241	245	249	252	256
80	252	256	260	264	268	272	276
85	272	276	280	284	288	292	297
90	292	297	301	305	309	314	318
95	314	318	323	327	332	336	341
100	336	341	346	351	355	360	365
105	360	365	370	375	380	385	390
110	385	390	396	401	406	412	417
115	412	417	422	428	433	439	445
120	439	445	450	456	462	468	474
125	468	474	480	486	492	498	504

6. Adjust refrigerant level to attain proper gage pressure.

Add refrigerant if the Liquid Gauge Pressure is lower than the chart value.

- a. Connect gauges to refrigerant bottle and unit as illustrated.
- b. Purge all hoses.
- c. Open bottle.
- d. Stop adding refrigerant when liquid line temperature and Liquid Gauge Pressure matches the charging chart Final Subcooling Target.

Recover refrigerant if the Liquid Gauge Pressure is higher than the chart value.

7. Stabilize the system.
 - a. Wait 20 minutes for the system condition to stabilize between adjustments.

Note: When the Liquid Line Temperature and Gauge Pressure approximately match the chart, the system is properly charged.

- b. Remove gauges.
- c. Replace service port caps to prevent leaks. Tighten finger tight plus an additional 1/6 turn.

8. Verify typical performance.

Refer to the Pressure Curves chapter to verify typical performance.



System Charge Adjustment

Figure 31. Charging the unit

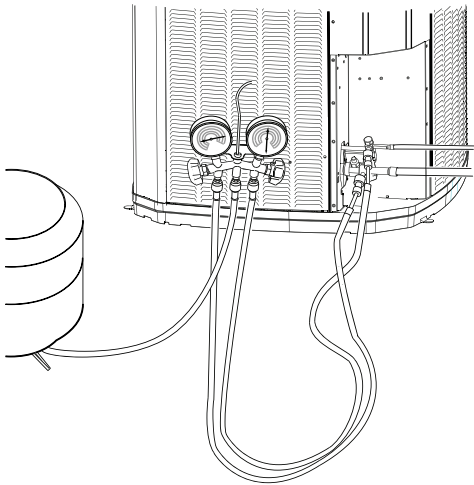
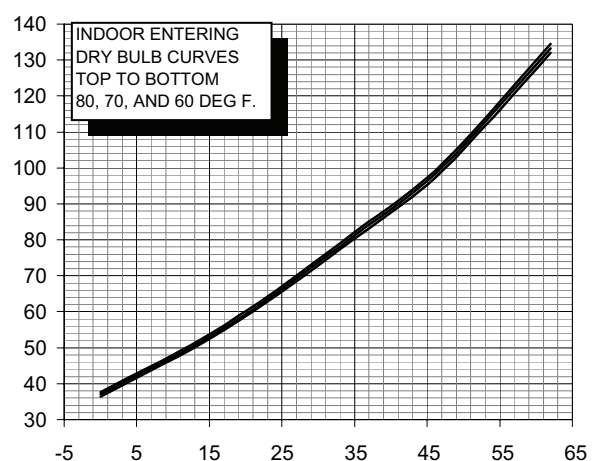
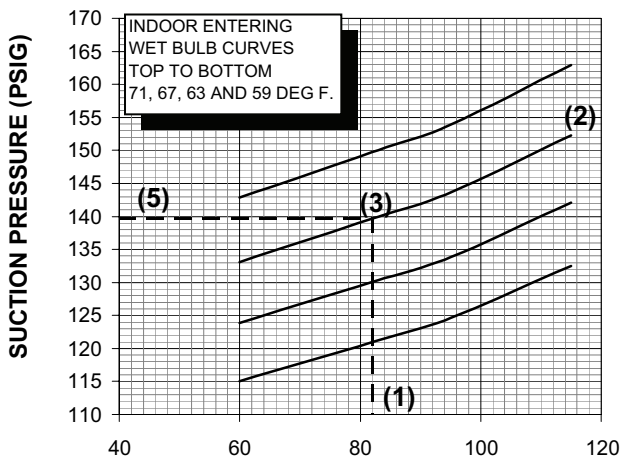
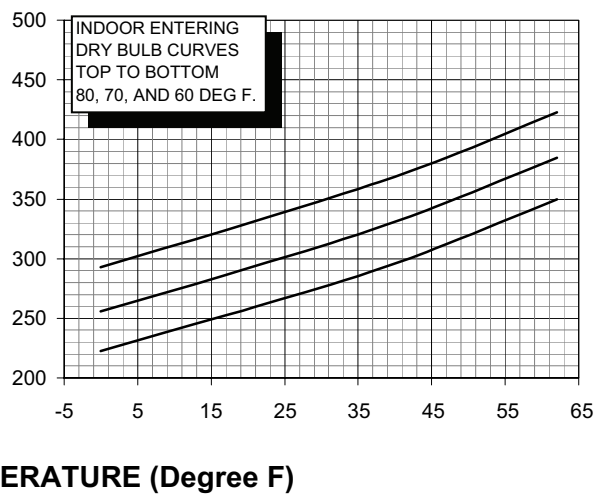
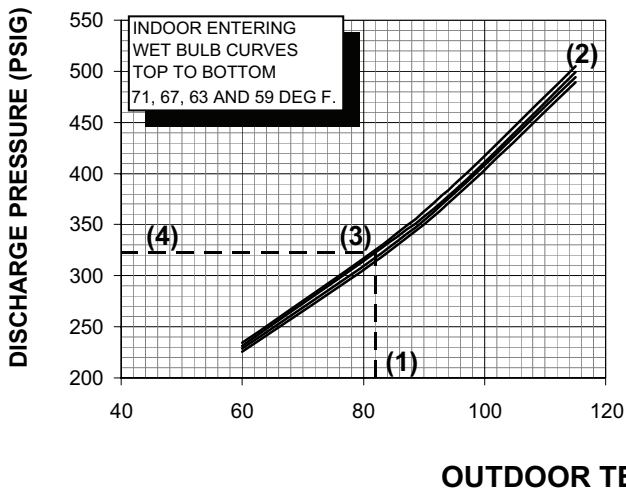

Figure 32. Pressure curve sample

Cooling @ 1450 SCFM

Heating @ 1350 SCFM



System Charge Adjustment

9. Record System Information for reference.
- Record system pressures and temperatures after charging is complete.
- Outdoor model number = _____
- Measured Outdoor Ambient = _____ °F
- Measured Indoor Ambient = _____ °F
- Measured Liquid Line Temperature = _____ °F
- Measured Suction Line Temperature = _____ °F
- Liquid Gauge Pressure = _____ PSI
- Suction Gauge Pressure = _____ PSI
10. If repairs must be made after system is charged, properly and safely remove and isolate refrigerant and purge the section of the system needing repair with oxygen free nitrogen prior to opening the circuit.
- The refrigerant charge should be recovered into the correctly marked recovery cylinders. Ensure that the

correct number of cylinders for holding the total system charge is available. Only use cylinders designated for the recovered refrigerant and labelled for that refrigerant. Cylinders shall be complete with pressure-relief valve and associated shut-off valves in good working order.

Ensure that the outlet for the vacuum pump is not close to any potential ignition sources and that ventilation is available.

The recovered refrigerant shall be returned to the refrigerant supplier in the correct recovery cylinder. Do not mix refrigerants.

If compressors or compressor oils are to be removed, ensure that they have been evacuated to an acceptable level to make certain that Flammable Refrigerant does not remain within the lubricant.

Table 6. Nitrogen purge times

Flow Rate	Lineset Length			
	<50 feet	<100 feet	<150 feet	<200 feet
CuFT/Hr				
15	2 Minutes	4 Minutes	6 Minutes	8 Minutes
30	1 Minute	2 Minutes	3 Minutes	4 Minutes
60	1 Minute	1 Minute	2 Minute	2 Minute

Table 7. Fixed orifice superheat charging table

	Indoor Wet Bulb Temp (F)																													
	50	51	52	53	54	55	56	57	58	59	60	61	62	63	64	65	66	67	68	69	70	71	72	73	74	75	76	77	78	
Outdoor Dry Bulb Temp. (F)	55	7	9	10	11	12	14	15	17	18	20	21	23	24	26	27	29	30	—	—	—	—	—	—	—	—	—	—	—	
	60	5	7	8	9	10	12	13	15	16	18	19	21	22	24	25	27	28	30	31	—	—	—	—	—	—	—	—	—	
	65	—	—	4	6	8	10	11	13	14	16	17	18	19	21	22	24	25	27	28	27	31	—	—	—	—	—	—	—	
	70	—	—	—	—	5	7	8	10	11	13	14	16	17	18	19	21	22	24	25	27	28	30	31	—	—	—	—	—	
	75	—	—	—	—	—	—	5	6	7	9	10	12	14	16	18	19	21	22	24	26	28	29	31	32	—	—	—	—	
	80	—	—	—	—	—	—	—	—	4	6	7	9	10	11	12	14	16	18	19	21	23	25	26	28	29	31	33	—	
	85	—	—	—	—	—	—	—	—	—	—	4	6	7	9	10	13	14	16	18	20	21	23	24	26	28	29	30	31	32
	90	—	—	—	—	—	—	—	—	—	—	—	—	4	6	8	10	11	13	14	16	18	20	22	24	25	27	28	30	31
	95	—	—	—	—	—	—	—	—	—	—	—	—	—	—	4	6	8	10	13	14	16	18	20	22	23	25	26	28	29
	100	—	—	—	—	—	—	—	—	—	—	—	—	—	—	—	—	6	8	10	12	13	16	18	20	21	23	25	27	29
	105	—	—	—	—	—	—	—	—	—	—	—	—	—	—	—	—	4	6	7	9	11	13	15	18	20	22	24	26	28
	110	—	—	—	—	—	—	—	—	—	—	—	—	—	—	—	—	—	—	4	7	9	11	13	16	18	21	23	26	28
115	—	—	—	—	—	—	—	—	—	—	—	—	—	—	—	—	—	—	—	—	—	6	9	12	14	16	19	21	24	26

Using a digital psychrometer, measure the return air wet-bulb temperature at the unit just before the coil. Also measure the outdoor dry-bulb temperature. Use these temperatures to locate the target superheat on the charging table. Do not attempt to charge the system if these conditions fall outside of this charging table.

Add refrigerant to decrease total superheat. remove refrigerant to increase total superheat. Always allow 10 to 15 minutes of operation after any refrigerant or air flow change prior to determining the final superheat.



System Charge Adjustment

Weigh-in Method for Charging

Weigh-In Method can be used for the initial installation, or anytime a system charge is being replaced. Weigh-In Method can also be used when power is not available to the equipment site or operating conditions (indoor/outdoor temperatures) are not in range to verify with the subcooling charging method.

Calculating charge using the weigh-in method:

1. Measure in feet the distance between the outdoor unit and the indoor unit and record on Line 1. Include the entire length of the line from the service valve to the IDU (minus 10 ft).

Line length (ft) = _____

2. Enter the charge multiplier (0.47 oz./ft for 3/8-inch and 0.30 oz./ft for 5/16-inch).

3. Multiply the total length of refrigerant tubing (Line 1) times the value on Step 2. Record the result on Line 3 of the Worksheet.

Step 1 x Step 2 = _____

4. This is the amount of refrigerant to weigh-in prior to opening the service valves.

Refrigerant = _____



Checkout Procedures

Operational and Checkout Procedures

Final phases of this installation are the unit Operational and Checkout Procedures. To obtain proper performance, all units must be operated and charge adjustments made.

Important: *Perform a final unit inspection to be sure that factory tubing has not shifted during shipment. Adjust tubing if necessary so tubes do not rub against each other when the unit runs. Also be sure that wiring connections are tight and properly secured.*

After installation has been completed, it is recommended that the entire system be checked against the following list:

- Leak check refrigerant lines.
- Properly insulate suction lines and fittings.
- Properly secure and isolate all refrigerant lines.
- Seal passages through masonry. If mortar is used, prevent mortar from coming into direct contact with copper tubing.
- Verify that all electrical connections are tight.
- Observe outdoor fan during on cycle for clearance and smooth operation.
- Be sure that indoor coil drain line drains freely. Pour water into drain pan.
- Be sure that supply registers and return grilles are open and unobstructed.
- Be sure that a return air filter is installed.
- Be sure that the correct airflow setting is used. (Indoor blower motor).
- Operate complete system in each mode to ensure safe operation.
- Check the MCB or RDS is operational.



Wiring Diagrams

Figure 33. Wiring diagram - models 036A3, 042A3, 048A3, and 060A3

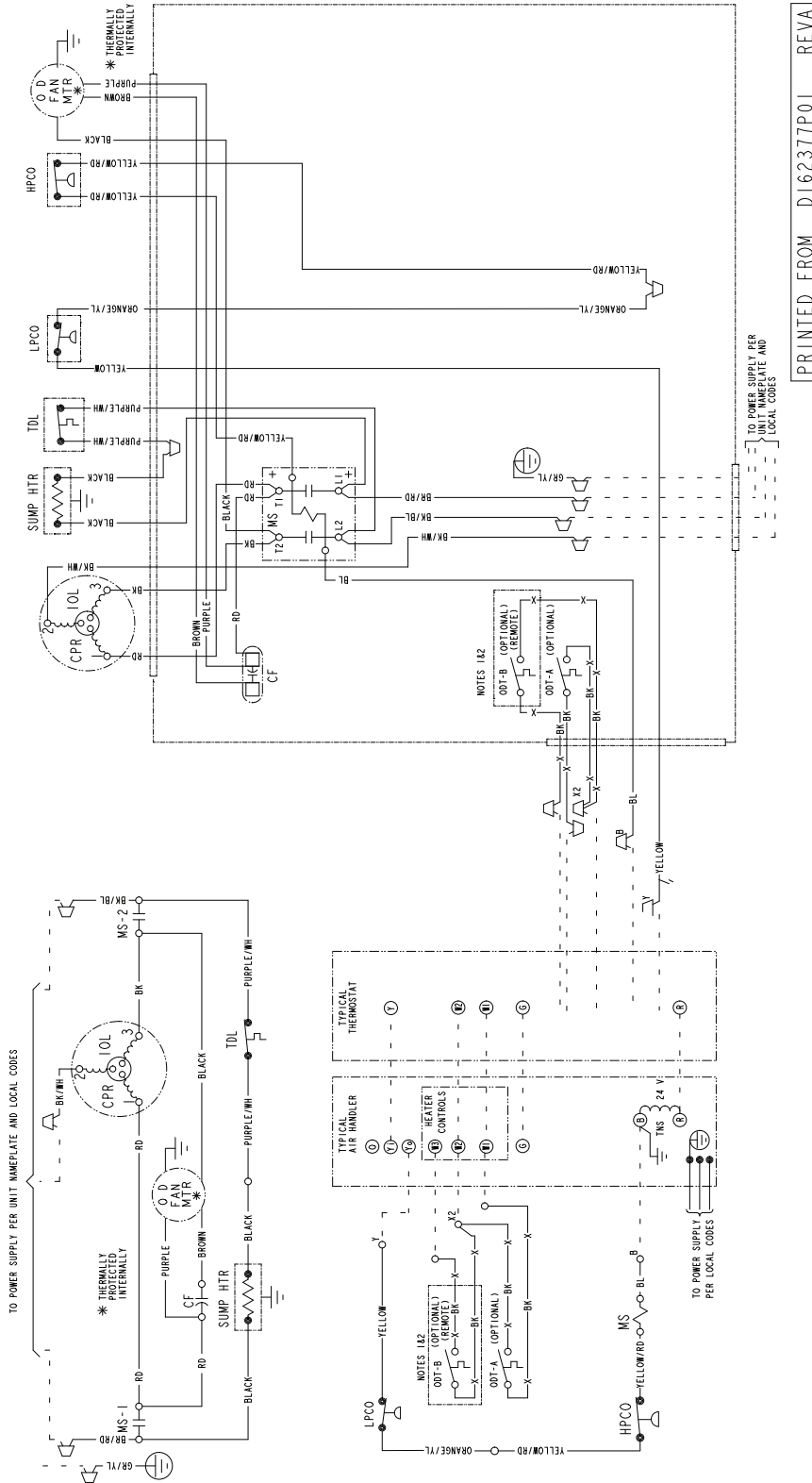

PRINTED FROM D162377P01 REVA

Figure 34. Wiring diagram - models 036A4, 042A4, 048A4, and 060A4

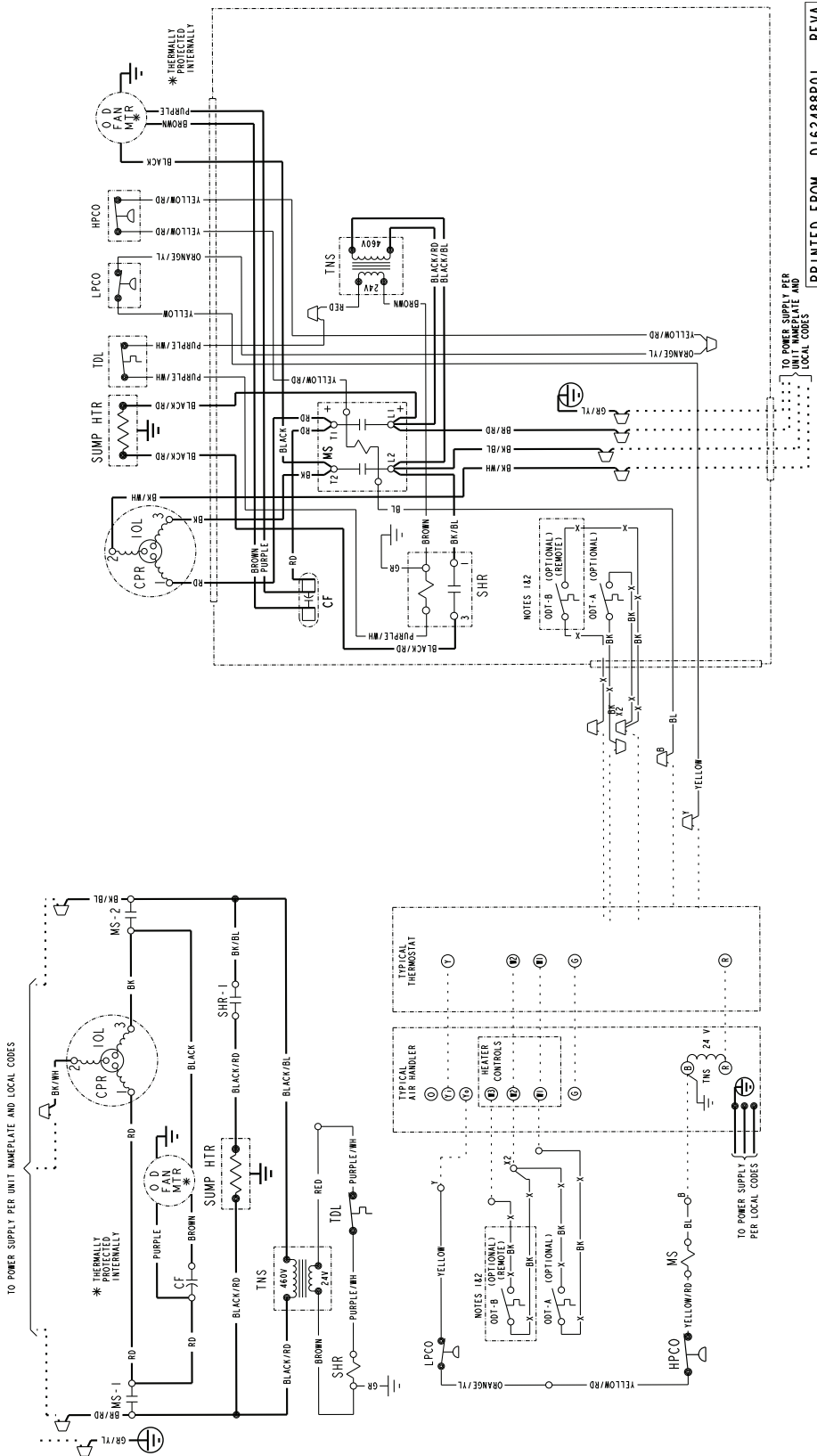

PRINTED FROM D162488P01 REVA

Wiring Diagrams

Figure 35. Wiring diagrams - notes and legend

NOTES:

1. IF ODT-B IS NOT USED, ADD JUMPER BETWEEN W2 & W3 AT AIR HANDLER.
IF USED, ODT-B MUST BE MOUNTED REMOTE OF CONTROL BOX IN AN APPROVED WEATHER PROOF ENCLOSURE.
2. IF ODT-A IS NOT USED, ADD JUMPER BETWEEN W1 & W2 AT AIR HANDLER.
3. LOW VOLTAGE (24 V.) FIELD WIRING MUST BE 18 AWG MIN.



NOTE:

MATERIAL: WHITE POLYPROPYLENE SUITABLE FOR USE IN OUTDOOR ENVIRONMENT.
 ADHESIVE: PRESSURE SENSITIVE ADHESIVE WITH RELEASE PAPER SUITABLE FOR OUTDOOR APPLICATION ON PAINTED OR GALVANIZED SHEET METAL SURFACES.
 SIZE : 8 1/2" X 11"

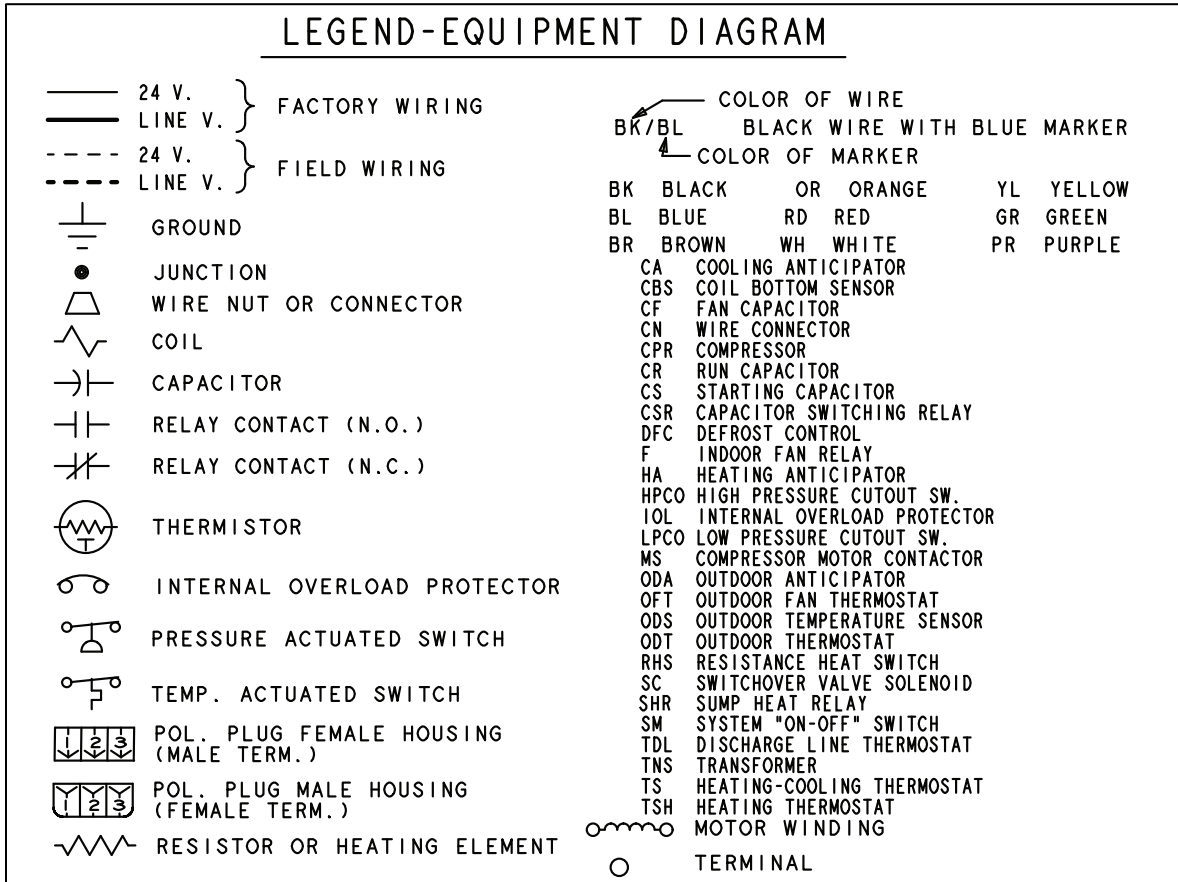

COOLING PERFORMANCE CAN BE CHECKED WHEN THE OUTDOOR TEMP IS ABOVE 65 DEG F.

1. TO CHECK COOLING PERFORMANCE, SELECT AND VERIFY THE PROPER INDOOR CFM.
2. ALLOW SYSTEM TO RUN UNTIL PRESSURES ARE STABILIZED.
3. MEASURE INDOOR WET BULB TEMPERATURE, OUTDOOR TEMPERATURE, SUCTION AND LIQUID PRESSURES.
4. ON THE TABLE, LOCATE OUTDOOR TEMPERATURE AND INDOOR WET BULB TEMPERATURE.
5. FIND THE INTERSECTION WITH THE COLUMN THAT CONTAINS THE OUTDOOR SIZE.
6. TARGET PRESSURES ARE LOCATED AT THE INTERSECTION BETWEEN OUTDOOR SIZE AND OPERATING TEMPERATURES.

ACTUAL:
 LIQUID PRESSURE SHOULD BE +/- 10 PSI OF TABLE
 SUCTION PRESSURE SHOULD BE +/- 3 PSI OF TABLE

**FOR CANADIAN INSTALLATIONS
 POUR INSTALLATIONS CANADIENNES**

CAUTION: NOT SUITABLE FOR USE ON SYSTEMS EXCEEDING 150V - TO - GROUND
ATTENTION: NE CONVIENT PAS AUX INSTALLATIONS DE PLLS DE 150 V A LA TERRE

NOTE

THREE PHASE MOTOR (S) FACTORY SUPPLIED IN THIS EQUIPMENT PROTECTED UNDER PRIMARY SINGLE-PHASE CONDITIONS.



Pressure Curves

Cooling performance can be checked when the outdoor temperature is above 65°F.

To check cooling performance, select the proper indoor CFM, all pressures to stabilize. Measure indoor wet bulb temperature, outdoor temperature, liquid and suction pressures.

On the plots:

1. Locate outdoor temperature
2. Locate indoor wet bulb
3. Find the intersection of the OD temperature and ID W.B
4. Read the discharge or suction pressure in the left column.

Example:

1. Outdoor temperature 82°F
2. In door wet bulb 67°F
3. At intersection
4. Discharge pressure at 600 CFM is 304 psig
5. Suction pressure at 600 CFM is 145 psig

Actual:

Discharge pressure should be +/- 10 psi of chart.
Suction pressure should be +/- 3 psi of chart.

Figure 36. Pressure curves – models 5TTA3036A, 5TTA3042A, and 5TTA3048A

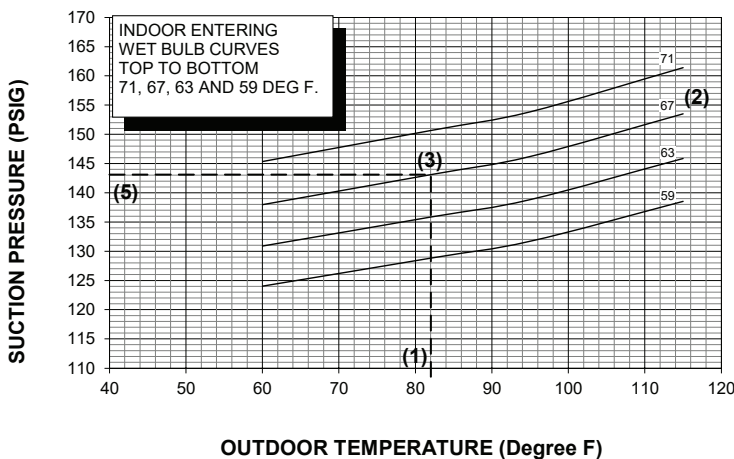
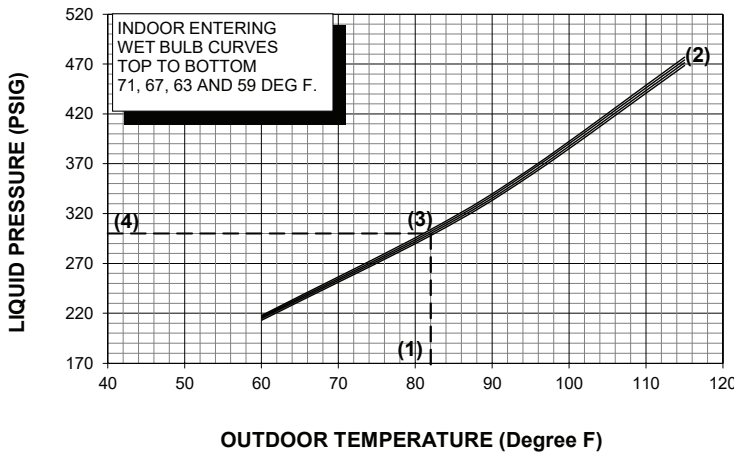

OD Model	Cooling @SCFM
5TTA3036A	950
5TTA3042A	1150
5TTA3048A	1350



Pressure Curves

Figure 37. Pressure curves - model 5TTA3060A

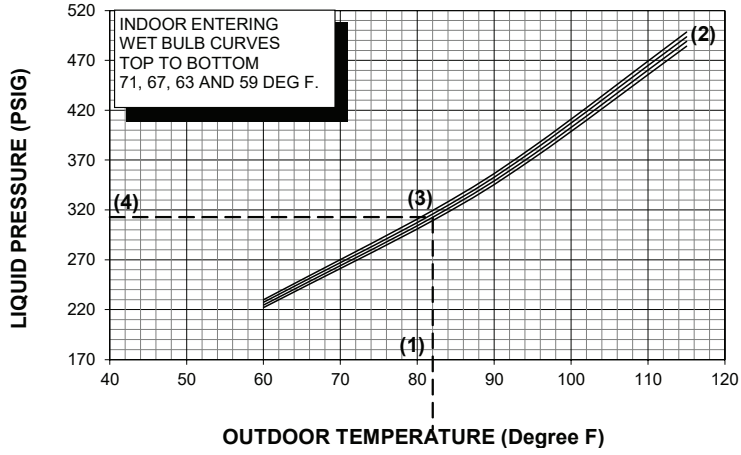

OD Model	Cooling @SCFM
5TTA3060A	1450

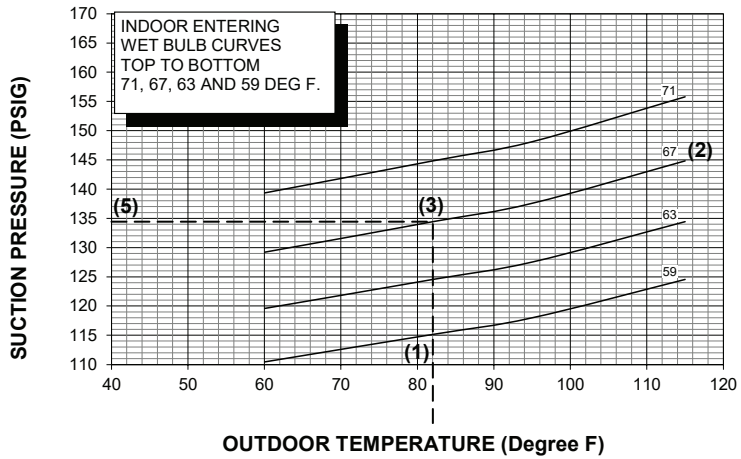

Refrigeration Circuits

Figure 38. Refrigeration cycle for model 036

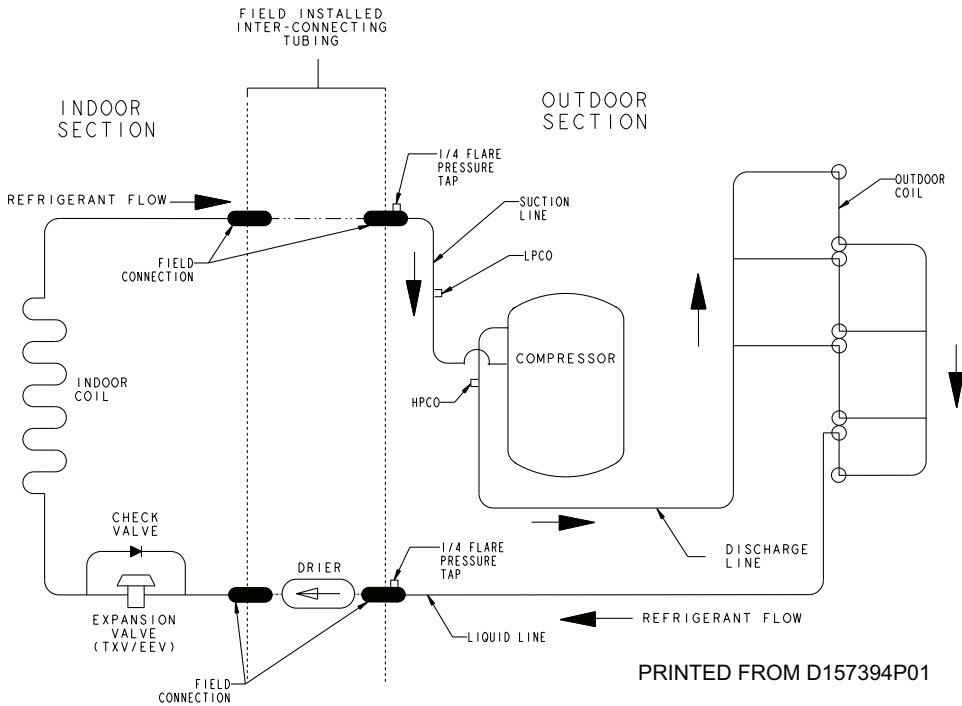

Figure 39. Refrigeration cycle for model 042

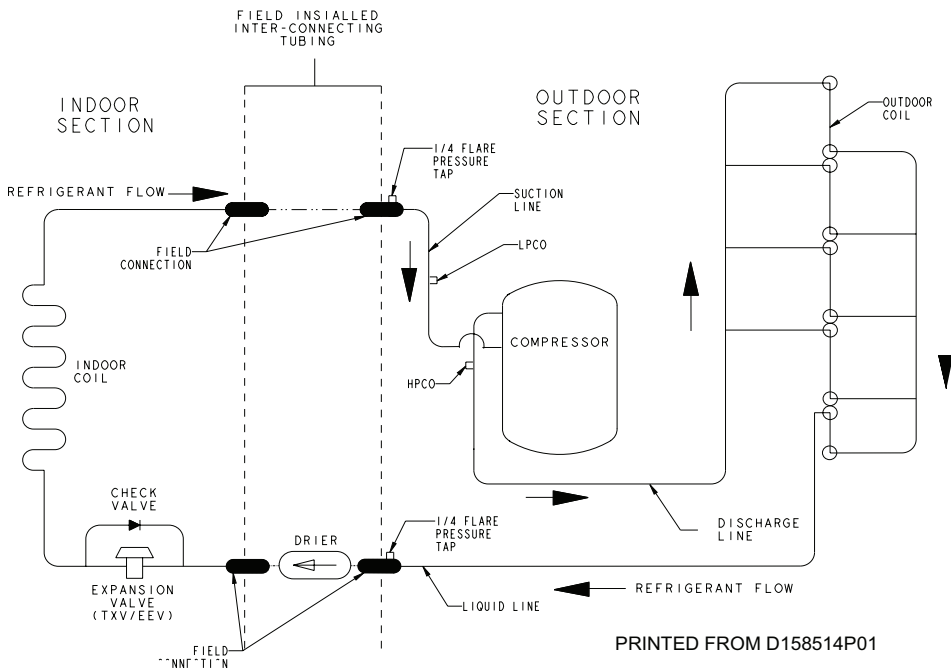
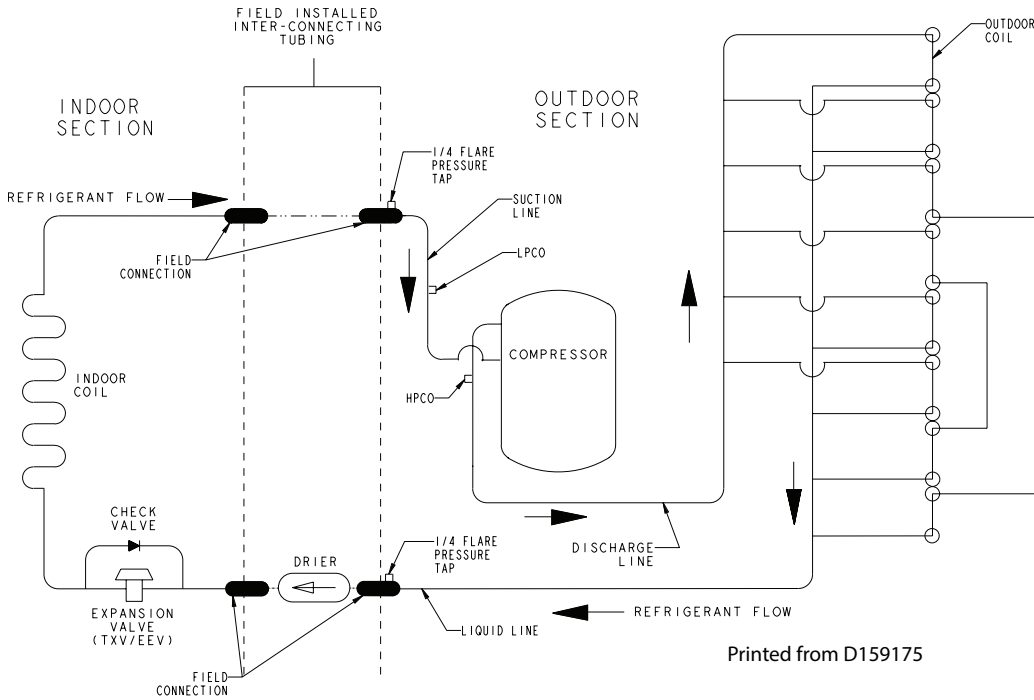

Figure 40. Refrigeration cycle for models 048 and 060



Printed from D159175

Refrigerant Detection System

The approved ID/OD combination will provide sufficient safe ventilation.

Airflow provided is sufficient to cover minimum room area including adjustments for altitude. All systems require a refrigerant detection system so no altitude adjustment factors are required.

Installer must ensure refrigerant detection system is connected and placed in appropriate orientation per application.

The control system power shall not be interrupted to ensure the refrigerant detection system is always functioning.

Please reference Indoor Unit installers guide for correct specification on refrigerant detection system.



Trane - by Trane Technologies (NYSE: TT), a global innovator - creates comfortable, energy efficient indoor environments for commercial and residential applications. For more information, please visit trane.com or tranetechnologies.com.



The AHRI Certified mark indicates Trane U.S. Inc. participation in the AHRI Certification program. For verification of individual certified products, go to ahridirectory.org.

Trane has a policy of continuous data improvement and it reserves the right to change design and specifications without notice. We are committed to using environmentally conscious print practices.