

Preliminary



Installer's Guide

Link Variable Speed Cold Climate Heat Pumps

5TCV0X36A
5TCV0X48A
5TCV0X60A
5TCV0X61A (Vapor Injection Model)

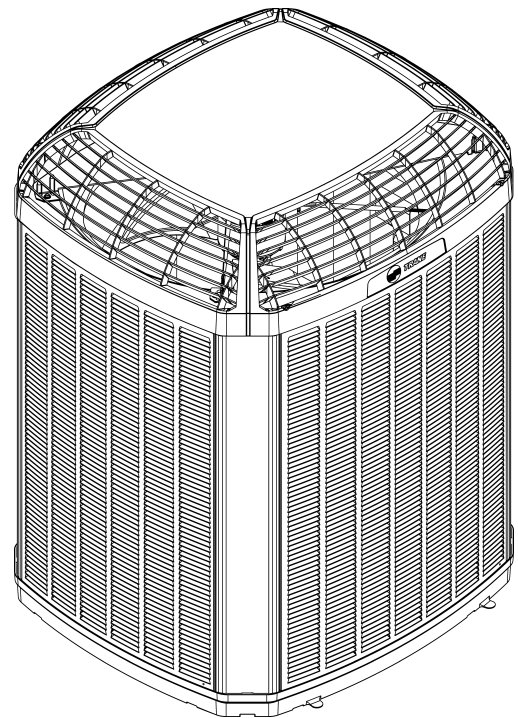

*Note: Graphics in this document are for representation only.
Actual model may differ in appearance.*

⚠ SAFETY WARNING

Only qualified personnel should install and service the equipment. The installation, starting up, and servicing of heating, ventilating, and air-conditioning equipment can be hazardous and requires specific knowledge and training. Improperly installed, adjusted or altered equipment by an unqualified person could result in death or serious injury. When working on the equipment, observe all precautions in the literature and on the tags, stickers, and labels that are attached to the equipment.



Introduction

Read this manual thoroughly before operating or servicing this unit.

This document is customer property and is to remain with this unit. Return to the service information pack upon completion of work.

Warnings, Cautions, and Notices

Safety advisories appear throughout this manual as required. Your personal safety and the proper operation of this machine depend upon the strict observance of these precautions.

The three types of advisories are defined as follows:



Indicates a potentially hazardous situation which, if not avoided, could result in death or serious injury.



Indicates a potentially hazardous situation which, if not avoided, could result in minor or moderate injury. It could also be used to alert against unsafe practices.



Indicates a situation that could result in equipment or property-damage only accidents.

Important Environmental Concerns

Scientific research has shown that certain man-made chemicals can affect the earth's naturally occurring stratospheric ozone layer when released to the atmosphere. In particular, several of the identified chemicals that may affect the ozone layer are refrigerants that contain Chlorine, Fluorine and Carbon (CFCs) and those containing Hydrogen, Chlorine, Fluorine and Carbon (HCFCs). Not all refrigerants containing these compounds have the same potential impact to the environment. Trane advocates the responsible handling of all refrigerants.

Important Responsible Refrigerant Practices

Trane believes that responsible refrigerant practices are important to the environment, our customers, and the air conditioning industry. All technicians who handle refrigerants must be certified according to local rules. For the USA, the Federal Clean Air Act (Section 608) sets forth the requirements for handling, reclaiming, recovering and recycling of certain refrigerants and the equipment that is used in these service procedures. In addition, some states or municipalities may have additional requirements that must also be adhered to for responsible management of refrigerants. Know the applicable laws and follow them.

⚠ WARNING

Proper Field Wiring and Grounding Required!

Failure to follow code could result in death or serious injury.

All field wiring **MUST** be performed by qualified personnel. Improperly installed and grounded field wiring poses **FIRE** and **ELECTROCUTION** hazards. To avoid these hazards, you **MUST** follow requirements for field wiring installation and grounding as described in **NEC** and your local/state/national electrical codes.

⚠ WARNING

Personal Protective Equipment (PPE) Required!

Failure to wear proper PPE for the job being undertaken could result in death or serious injury.

Technicians, in order to protect themselves from potential electrical, mechanical, and chemical hazards, **MUST** follow precautions in this manual and on the tags, stickers, and labels, as well as the instructions below:

- **Before installing/servicing this unit, technicians MUST put on all PPE required for the work being undertaken (Examples; cut resistant gloves/sleeves, butyl gloves, safety glasses, hard hat/bump cap, fall protection, electrical PPE and arc flash clothing). ALWAYS refer to appropriate Safety Data Sheets (SDS) and OSHA guidelines for proper PPE.**
- **When working with or around hazardous chemicals, ALWAYS refer to the appropriate SDS and OSHA/GHS (Global Harmonized System of Classification and Labelling of Chemicals) guidelines for information on allowable personal exposure levels, proper respiratory protection and handling instructions.**
- **If there is a risk of energized electrical contact, arc, or flash, technicians MUST put on all PPE in accordance with OSHA, NFPA 70E, or other country-specific requirements for arc flash protection, PRIOR to servicing the unit. NEVER PERFORM ANY SWITCHING, DISCONNECTING, OR VOLTAGE TESTING WITHOUT PROPER ELECTRICAL PPE AND ARC FLASH CLOTHING. ENSURE ELECTRICAL METERS AND EQUIPMENT ARE PROPERLY RATED FOR INTENDED VOLTAGE.**

⚠ WARNING

Follow EHS Policies!

Failure to follow instructions below could result in death or serious injury.

- All Trane personnel must follow the company's Environmental, Health and Safety (EHS) policies when performing work such as hot work, electrical, fall protection, lockout/tagout, refrigerant handling, etc. Where local regulations are more stringent than these policies, those regulations supersede these policies.
- Non-Trane personnel should always follow local regulations.

⚠ WARNING

Cancer and Reproductive Harm!

This product can expose you to chemicals, including lead, which are known to the State of California to cause cancer and birth defects or other reproductive harm. For more information go to www.P65Warnings.ca.gov.

⚠ WARNING

Safety Hazard!

Failure to follow instructions below could result in death or serious injury or property damage.

This unit is not to be used by persons (including children) with reduced physical, sensory, or mental capabilities, or lack of experience and knowledge, unless they have been given supervision or instruction concerning the use of the appliance by a person responsible for their safety.

Do not allow children to play or climb on the unit or to clean or maintain the unit without supervision.

⚠ WARNING

Hazardous Voltage!

Failure to disconnect power before servicing could result in death or serious injury.

Disconnect all electric power, including remote disconnects before servicing. Follow proper lockout/tagout procedures to ensure the power can not be inadvertently energized. Verify that no power is present with a voltmeter.

⚠ WARNING

R-454B Refrigerant!

Failure to use proper equipment or components as described below could result in death, serious injury, or equipment damage.

- Use ONLY R-454B rated service equipment with these units.
- All R-454B systems with variable speed compressors use variable speed compressor oil, which absorbs moisture from the air. To limit this hygroscopic action, keep the system sealed. If exposed to air for over 4 hours, replace the compressor oil.
- Never break a vacuum with air and always replace driers when opening the system to replace components.

⚠ WARNING

Hot Surface!

Failure to follow instructions below could result in minor to severe burns.

Do not touch top of compressor. It may be hot.

⚠ WARNING

Refrigerant under High Pressure!

Failure to follow instructions below could result in an explosion which could result in death or serious injury or equipment damage.

System contains oil and refrigerant under high pressure. Recover refrigerant to relieve pressure before opening the system. See unit nameplate for refrigerant type. Do not use non-approved refrigerants, refrigerant substitutes, or refrigerant additives.

⚠ WARNING

Grounding Required!

Failure to follow instructions below could result in death or serious injury, or property damage.

- Reconnect all grounding devices.
- All parts of this product that are capable of conducting electrical current are grounded.
- If grounding wires, screws, straps, clips, nuts, or washers used to complete a path to ground are removed for service, they must be returned to their original position and properly fastened.



Preliminary

Introduction

⚠ WARNING

System Charge!

Failure to follow instructions below could result in abrupt release of system charge and could result in serious injury or property damage.

When opening the suction and liquid line service valve, turn the valve stem counterclockwise only until the stem contacts the rolled edge. Do not apply torque.

⚠ WARNING

Electrical Shock Hazard!

Failure to follow instructions below could result in death or serious injury or property damage.

Confirm proper grounding before connecting electrical supply.

⚠ WARNING

Risk of Fire — Flammable Refrigerant!

Failure to follow instructions below could result in death or serious injury, and equipment damage.

- To be repaired only by trained service personnel.
- Do not puncture refrigerant tubing.
- Dispose of properly in accordance with federal or local regulations.

⚠ WARNING

Ventilation Required!

Failure to follow instructions below could result in death or serious injury or property damage.

Confirm the area is adequately ventilated before breaking into the system or conducting any hot work.

⚠ WARNING

Risk of Fire!

Failure to follow instructions below could cause a fire which could result in death, serious injury, and/or property damage.

Use three specified access points on outdoor unit to evacuate refrigerant when servicing compressor.

NOTICE

Equipment Damage!

Failure to follow instructions below could result in equipment damage.

Use only R-454B rated indoor models, service equipment, and components with these units.

⚠ CAUTION

Caution!

Failure to follow instructions below could result in minor to moderate injury or equipment damage.

- For brazing, confirm all joints are brazed, not soldered.
- For mechanical connections, confirm a negative leak test.
- Inspect lines and use proper service tools.

Copyright

This document and the information in it are the property of Trane, and may not be used or reproduced in whole or in part without written permission. Trane reserves the right to revise this publication at any time, and to make changes to its content without obligation to notify any person of such revision or change.

Trademark

All trademarks referenced in this document are the trademarks of their respective owners.



Table of Contents

General Information	6	Electrical – Low Voltage.....	22
Approved Controllers.....	6	Link Low Voltage Wire Connectors	23
Unit Location Considerations	7	Refrigerant Detection System	
Piping Guidelines.....	7	Guidelines.....	23
Refrigerant Line and Service Valve		Electrical – High Voltage	24
Connection Sizes.....	7	Power Supply	24
R-454B Refrigerant Charging Chart	9	Disconnect Switch	24
Refrigerant Properties.....	10	High Voltage Ground.....	24
Location Suggestions	11	Integrated Variable Speed Control Board	
Locations for the Most Reliability	11	LED Indicators	25
Cold Climate Considerations – Heat		Start-up	26
Pump Only	11	System Charge Adjustment	27
Coastal Considerations.....	12	Temperature Measurements	27
Unit Preparation	13	Subcooling Charging Corrections	27
Setting the Unit on a Support Pad	13	Charging the Unit.....	28
Refrigerant Line Considerations	14	Subcooling Charging Below 55°F Outdoor	
Factory Charge.....	14	Temperature	29
Required Refrigerant Line Length	14	Initial Install: Weigh-in Method.....	29
Refrigerant Line Insulation	14	Service: Check Charge Mode –	
Reuse Existing Refrigerant Lines	14	Heating	30
Refrigerant Line Routing Precautions.....	14	Defrost Control – Heat Pump Only.....	32
Isolation from a Joist/Rafter	15	Demand Defrost.....	32
Isolation in Wall Spaces	15	Fault Identification	32
Isolation Through a Wall	16	Defrost Enabled	32
Refrigerant Line Brazing	17	Defrost Initiation.....	32
Braze the Refrigerant Lines	17	Forced Defrost	32
Check for Refrigerant Line Leaks	19	Checkout Procedures	34
Evacuation and Servicing	20	Symbols	35
Evacuate the Refrigerant Lines and Indoor		Notices.....	36
Coil.....	20	FCC Notice	36
Servicing	20	IC Notice	36
Service Valves	20		
Open the Gas Service Valve First	20		
Open the Liquid Service Valve			
Second	21		

General Information



The Diagnostics Mobile App is available by scanning a QR code above, the one located inside this unit or by searching for the Trane or American Standard Diagnostics App in your App Store®. This system must include a A/T HUI2360A200U thermostat and a TSYS2C60A2VVU system controller to operate and is Link communicating only.

Notes:

- This unit is Link communicating only.
- This unit requires software version 8.0 or later on the SC360 and UX360.
- R-454B refrigerant is a blend and should be added to the system in liquid form only.

Approved Controllers

UX360 Smart Thermostat with SC360 System Controller

Note: See AHRI directory for approved indoor and outdoor model combinations. Only Trane coils and air handlers are approved for use with variable speed outdoor unit.

Table 1. Operating range

Mode	Model	Operating Range
Cooling	3 to 5 Ton	55°F to 115°F
Heating	3 to 5 Ton	0°F to 66°F

Important: Use caution when cleaning outdoor coil to ensure no water enters the electrical control compartment. When cleaning coil from inside the compressor compartment, take special care not to spray water towards the top rows of the coil near the control panel. Water may enter the control compartment and drive damaging the electronics. Disconnect all electric power, including remote disconnects before servicing.

Figure 1. Warning label

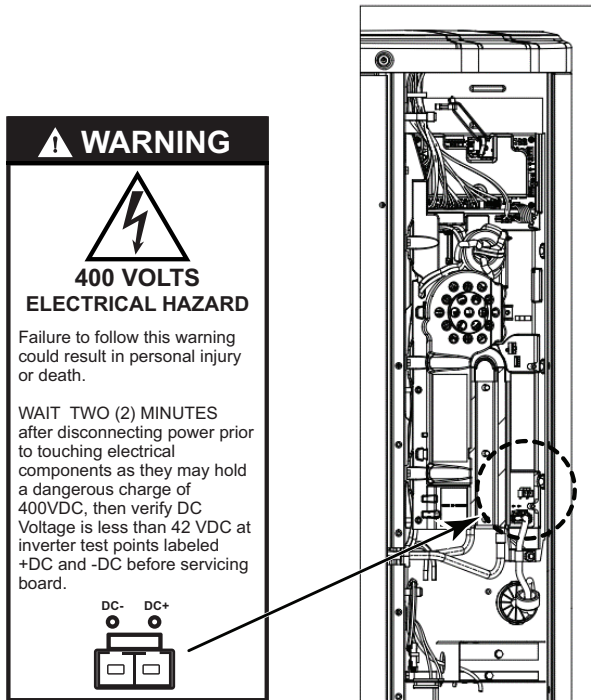

Unit Location Considerations

Piping Guidelines

Piping material, pipe routing, and installation includes protection from physical damage in operation and service, and be in compliance with national, state and local codes. All field joints must be accessible for inspection prior to being covered or enclosed. Installation of pipe work will be kept to a minimum. Provisions shall be made for expansion and contraction of long runs of piping.

- When mounting the outdoor unit on a roof, verify that the roof will support the unit weight.
- Properly selected isolation is recommended to alleviate sound or vibration transmission to the building structure.

Figure 2. Unit dimensions

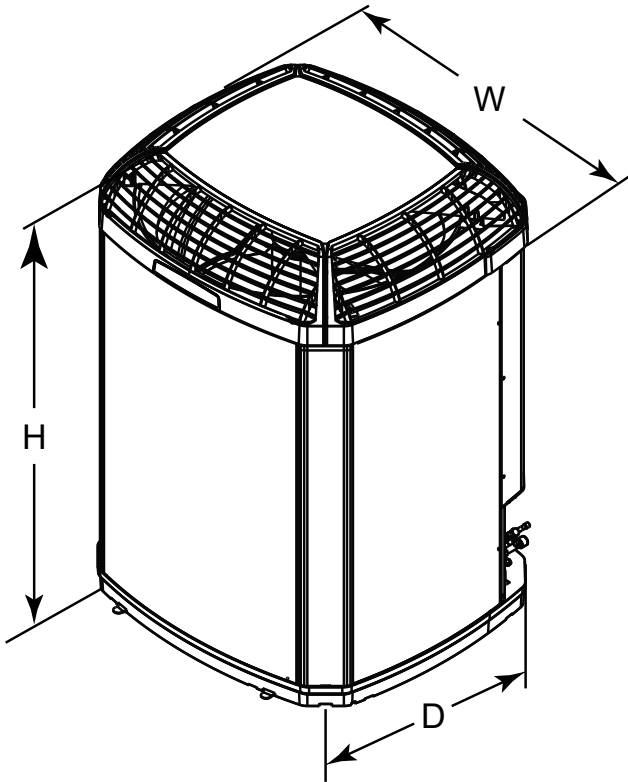

Table 2. Unit dimensions and weights

Models	H x D x W (inches)	Weight ^(a) (lb)
5TCV0X36A	52 x 34 x 37	272
5TCV0X48A	52 x 34 x 37	272
5TCV0X60A	52 x 34 x 37	272
5TCV0X61A	52 x 34 x 37	275

^(a) Weight values are estimated (uncrated).

Refrigerant Line and Service Valve Connection Sizes

The charts below are estimations. For more accurate and up-to-date lineset recommendations, use the Piping Program.

Important: For 3, 4, and 5-ton systems with 3/8-inch lineset diameters, use design subcooling for all length and lift combinations.

Note: The system will auto-configure airflow in Link mode.

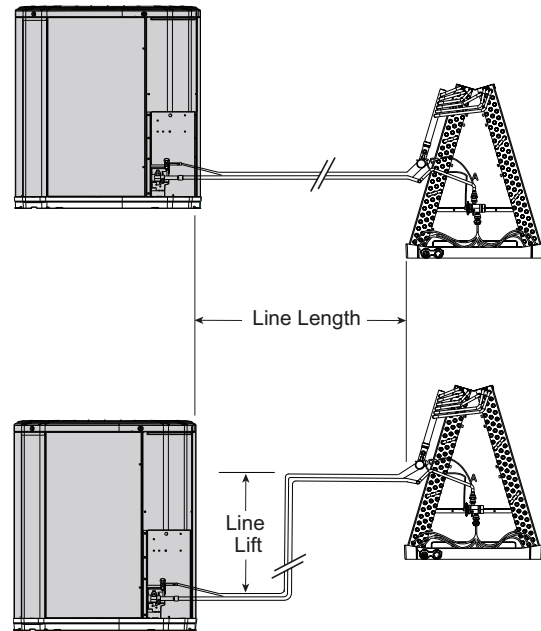

See (a), (b), and (c) footnotes for specific model details

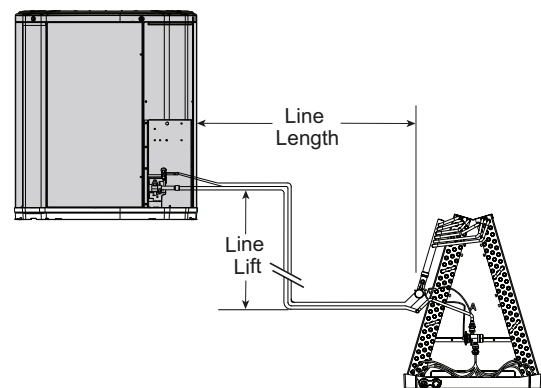



Preliminary

Unit Location Considerations

Table 3. Refrigerant line and service valve connection sizes

Model	Rated Line Sizes		Service Valve Connection Sizes	
	Vapor Line (inches)	Liquid Line (inches)	Vapor Line Connection (inches)	Liquid Line Connection (inches)
5TCV0X36A	5/8 ^(a) (b)	5/16	3/4	5/16
5TCV0X48A	3/4	5/16	3/4	5/16
5TCV0X60A	3/4	5/16	3/4	5/16
5TCV0X61A	3/4	5/16	3/4	5/16

^(a) For maximum refrigerant line length between the outdoor and indoor units, refer to the table above.

^(b) Select correct line set size in set up app. Default is set to alternate line sizes.

Table 4. Lineset sizes and length – X36 models

Vapor Line	Liquid Line	Length	Vertical Change
1/2	5/16	25	0
5/8			
3/4			
1/2	3/8	120	50
5/8		200	
3/4			
Legend:			
Smallest Allowed			
Ratings/Primary			
Legacy			

Table 5. Lineset sizes and length – X48 models

Vapor Line	Liquid Line	Length	Vertical Change
5/8	5/16	25	0
3/4			0
7/8			0
5/8	3/8	150	50
3/4			50
7/8			10
Legend:			
Smallest Allowed			
Ratings/Primary			
Legacy			

Table 6. Lineset sizes and length – X60 and X61 models

Vapor Line	Liquid Line	Length	Vertical Change
5/8	5/16	25	0
3/4			0
7/8			0
5/8	3/8	110	50
3/4		150	50
7/8			10

Table 6. Lineset sizes and length – X60 and X61 models (continued)

Vapor Line	Liquid Line	Length	Vertical Change
Legend:			
Smallest Allowed			
Ratings/Primary			
Legacy			

Table 7. Alternate refrigerant line and service valve connection sizes

Model	Rated Line Sizes		Service Valve Connection Sizes	
	Vapor Line (inches)	Liquid Line (inches)	Vapor Line Connection (inches)	Liquid Line Connection (inches)
5TCV0X36A	1/2, 3/4 ^(a) (b)	3/8	3/4	5/16
5TCV0X48A	5/8, 7/8	3/8	3/4	5/16
5TCV0X60A	5/8, 7/8	3/8	3/4	5/16
5TCV0X61A	5/8, 7/8	3/8	3/4	5/16

^(a) For max length of refrigerant lines from outdoor to indoor unit see [3Refrigerant line and service valve connection sizes](#), p. 8.

^(b) Select correct line set size in set up app. Default is set to alternate line sizes.

R-454B Refrigerant Charging Chart

Table 8. Refrigerant chart

Liquid Temp (°F)	Design Subcooling (°F)						
	8	9	10	11	12	13	14
	Liquid Gauge Pressure (psig)						
55	170	172	175	178	181	184	187
60	184	187	190	194	197	200	203
65	200	203	206	210	213	217	220
70	217	220	223	227	230	234	238
75	234	238	241	245	249	252	256
80	252	256	260	264	268	272	276
85	272	276	280	284	288	292	297
90	292	297	301	305	309	314	318
95	314	318	323	327	332	336	341
100	336	341	346	351	355	360	365
105	360	365	370	375	380	385	390
110	385	390	396	401	406	412	417
115	412	417	422	428	433	439	445
120	439	445	450	456	462	468	474
125	468	474	480	486	492	498	504

Note: When charging to Subcooling values, use the Bubble Temp chart. If referencing Superheat, use the Dew Point chart.



Unit Location Considerations

Refrigerant Properties

Table 9. Refrigerant properties

Pgauge (psig)	Superheat Dew Table (°F)	Subcooling Bubble Table (°F)
30	-12	-14
35	-7	-9
40	-2	-4
45	2	0
50	6	4
55	10	7
60	13	11
65	17	14
70	20	18
75	23	21
80	26	24
85	29	26
90	31	29
95	34	32
100	37	34
105	39	37
110	41	39
115	44	41
120	46	44
125	48	46
130	50	48
135	52	50
140	54	52
145	56	54
150	58	56
155	60	58
160	62	60
165	64	61
170	66	63
175	67	65
180	69	67
185	71	68
190	72	70
195	74	71
200	75	73
205	77	75
210	78	76
215	80	78
220	81	79
225	83	80
230	84	82
235	86	83
240	87	85

Table 9. Refrigerant properties (continued)

Pgauge (psig)	Superheat Dew Table (°F)	Subcooling Bubble Table (°F)
245	88	86
250	90	87
255	91	89
260	92	90
265	94	91
270	95	93
275	96	94
280	97	95
285	99	96
290	100	97
295	101	99
300	102	100
305	103	101
310	104	102
315	106	103
320	107	104
325	108	105
330	109	107
335	110	108
340	111	109
345	112	110
350	113	111
355	114	112
360	115	113
365	116	114
370	117	115
375	118	116
380	119	117
385	120	118
390	121	119
395	122	120
400	123	121
405	124	122
410	125	123
415	126	124
420	127	125
425	128	125
430	128	126
435	129	127
440	130	128
445	131	129
450	132	130
455	133	131
460	134	132

Table 9. Refrigerant properties (continued)

Pgauge (psig)	Superheat Dew Table (°F)	Subcooling Bubble Table (°F)
465	134	132
470	135	133
475	136	134
480	137	135
485	138	136
490	139	137
495	139	137
500	140	138
505	141	139
510	142	140
515	143	141
520	143	141
525	144	142
530	145	143
535	146	144
540	146	145
545	147	145
550	148	146

Location Suggestions

Generic ODU Location Suggestions:

Locations for the Most Reliability

- Confirm that the top discharge area is unrestricted at least 5 feet above the unit.
- Provide at least 3 feet of clearance in front of the control box (access panels) and any other side requiring service.
- Do not locate close to bedrooms as operational sounds may be objectionable.
- Avoid locations near windows and similar areas where condensation and freezing defrost vapor can annoy a customer.
- Position the outdoor unit a minimum of 12 inches from any wall or surrounding shrubbery to ensure adequate airflow.
- The unit location must be far enough away from any structure to prevent excess roof runoff water or icicles from falling directly on the unit.

Figure 3. Ideal location shown

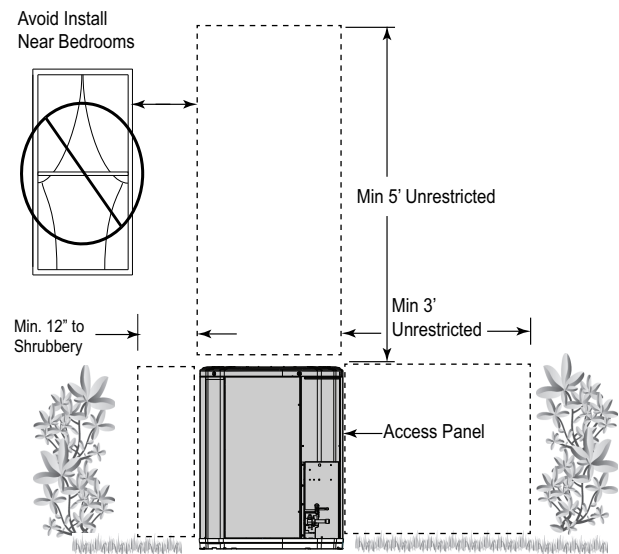
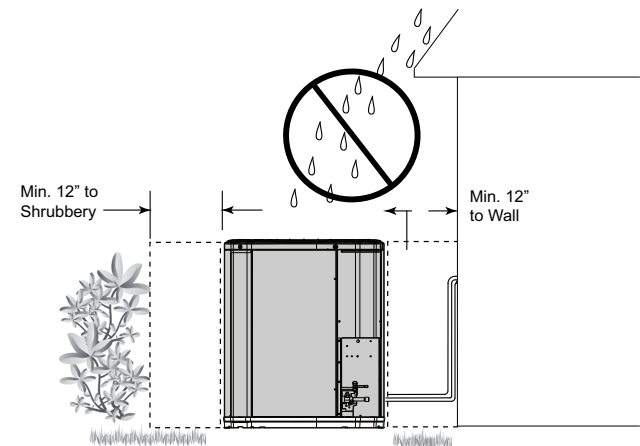

Figure 4. Do not install near water runoff



Cold Climate Considerations – Heat Pump Only

Note: It is recommended that these precautions be taken for units being installed in areas where snow accumulation and prolonged below-freezing temperatures occur.

- Units should be elevated 3 to 12 inches above the pad or rooftop, depending on the local climate. This additional height will allow drainage of snow and ice melted during defrost cycle prior to its refreezing. Verify that the drain holes in the unit base pan are not obstructed, preventing drainage of defrost water.
- If possible, avoid locations that are likely to accumulate snow drifts. If not possible, a snow drift barrier should be installed around the unit to prevent a build-up of snow on the sides of the unit.



Preliminary

Unit Location Considerations

Figure 5. Cold climate considerations

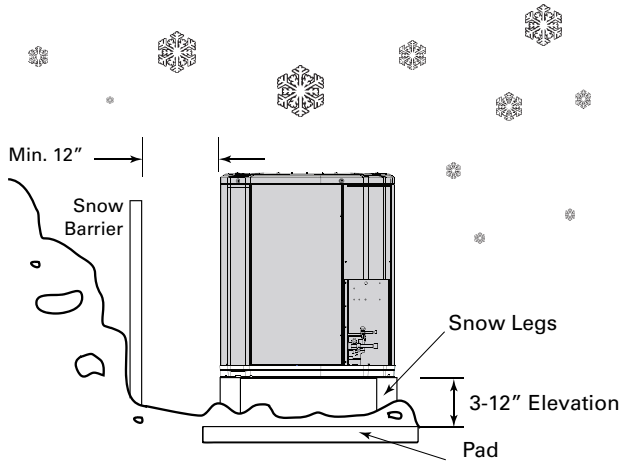

Coastal Considerations

If installed within one mile of salt water, including seacoasts and inland waterways, models without factory supplied Seacoast Salt Shields require the addition of BAYSEAC001 (Seacoast Kit) at installation time.

Unit Preparation

1. Check for the unit for damage. If you find damage, contact the carrier immediately.

Figure 6. Damaged unit

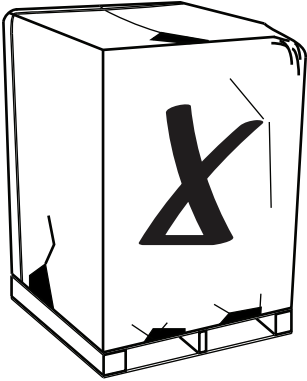

2. Use a sharp tool to remove the tabs securing the unit to the pallet.

Figure 7. Remove the tabs

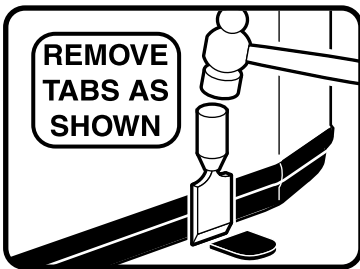

Setting the Unit on a Support Pad

When installing the unit on a support pad, such as a concrete slab, consider the following:

- The pad should be at least 1-inch larger than the unit on all sides.
- The pad must be separate from any structure.
- The pad must be level.
- The pad should be high enough above grade to allow for drainage.
- The pad location must comply with national, state, and local codes.

Figure 8. Install the unit on a support pad

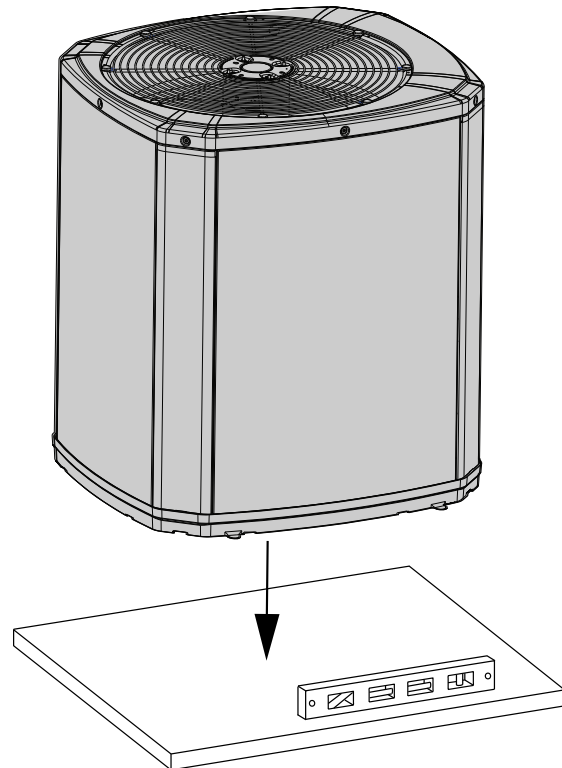

Refrigerant Line Considerations

Factory Charge

The units are factory-charged for 25 feet of 3/8-inch lineset. Always verify proper system charge using subcooling (TXV/EEV).

Required Refrigerant Line Length

Determine the required line length and lift. You will need this to determine the subcooling charging corrections later in the installation process.

Total Line Length = _____ Feet

Total Vertical Change (lift) = _____ Feet

Figure 9. Example of measuring refrigerant line

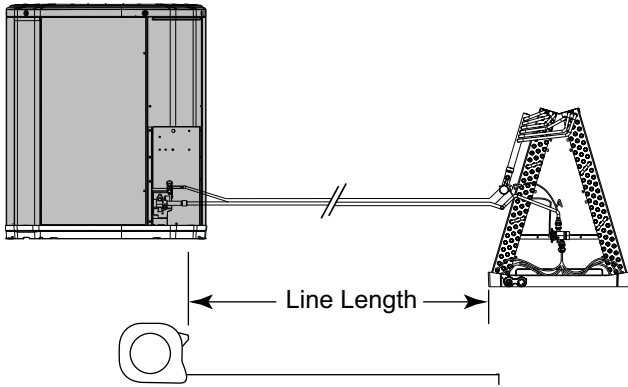

Refrigerant Line Insulation

Important: The vapor line must always be insulated. Do not allow the liquid line and vapor line to come in direct (metal to metal) contact.

Note: The vapor line must always be insulated. Insulating the liquid line through attic spaces may benefit system performance by minimizing heat gain in the liquid line.

Figure 10. Refrigerant line insulation

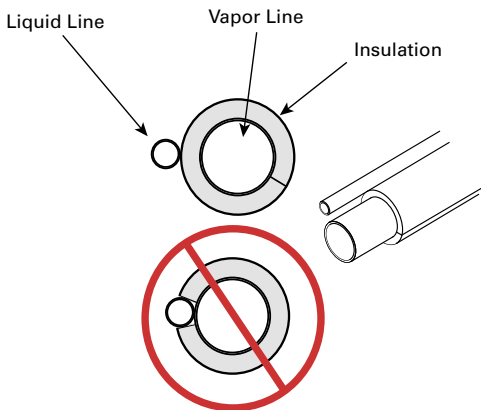

Reuse Existing Refrigerant Lines

⚠ CAUTION

Brazed Joints!

Failure to follow instructions below could result in minor to moderate injury or equipment damage. When using existing refrigerant lines, verify all joints are brazed and not soldered.

For retrofit applications, where the existing indoor evaporator coil and/or refrigerant lines will be used, the following precautions should be taken.

- Confirm that the indoor evaporator coil and refrigerant lines are the correct size.
- Verify that the refrigerant lines are free of leaks, acid, and oil.

Important: For more information, see publication SS-APG020*-EN.

Figure 11. Refrigerant line example

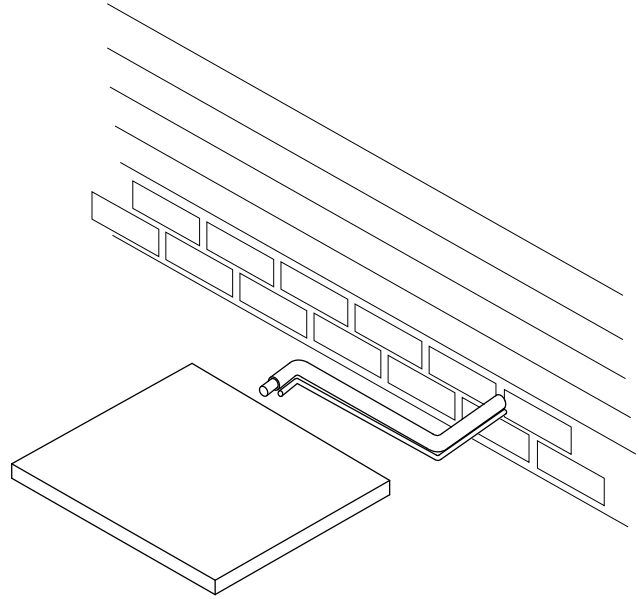

Refrigerant Line Routing Precautions

Important:

- Comply with National, State, and Local Codes when isolating line sets from joists, rafters, walls, or other structural elements.
- For buried linesets, see publication SS-APG020*-EN.
- Take precautions to prevent noise within the building structure due to vibration transmission from the refrigerant lines.

Review the below examples:

- When the refrigerant lines must be fastened to floor joists or other framing in a structure, use isolation type hangers.
- Isolation hangers should also be used when refrigerant lines are run in stud spaces or enclosed ceilings.
- Where the refrigerant lines run through a wall, sill or enclosed ceiling- they should be insulated, isolated and serviceable if any braze connections are present.

- Isolate the lines from all duct work.
- Minimize the number of 90° turns.

Isolation from a Joist/Rafter

Secure the vapor line from joists using isolators every 8 feet. Secure liquid line directly to insulated vapor line using tape, wire, or other appropriate method every 8 feet.

Figure 12. Isolation from a joist/rafter

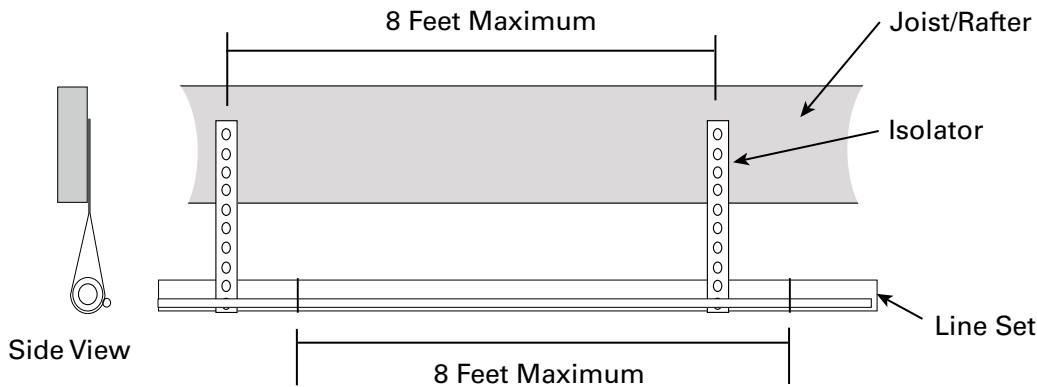

Isolation in Wall Spaces

Secure the vapor line from the joists using isolators every 8 feet. Secure the liquid line directly to the insulated vapor

line using tape, wire, or other appropriate method every 8 feet.

Figure 13. Isolation in wall spaces

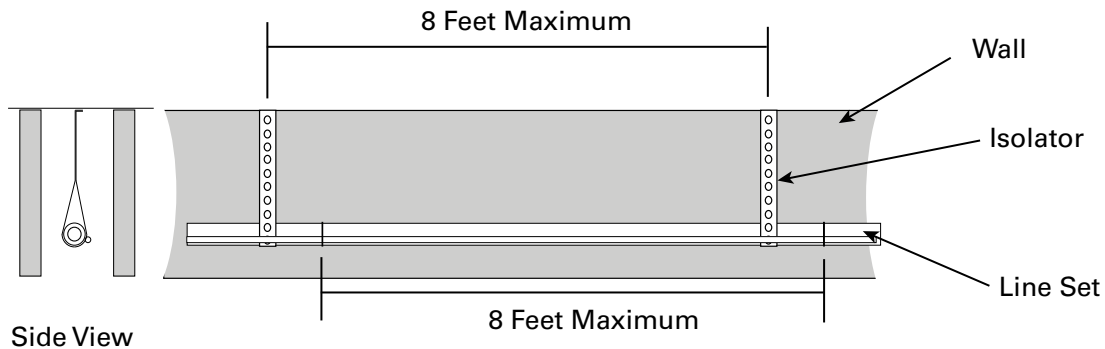

Isolation Through a Wall

Figure 14. Isolation through a wall

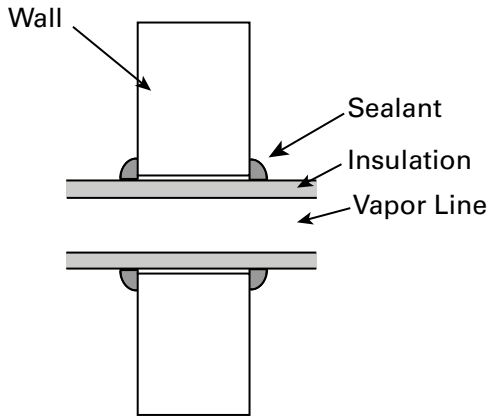
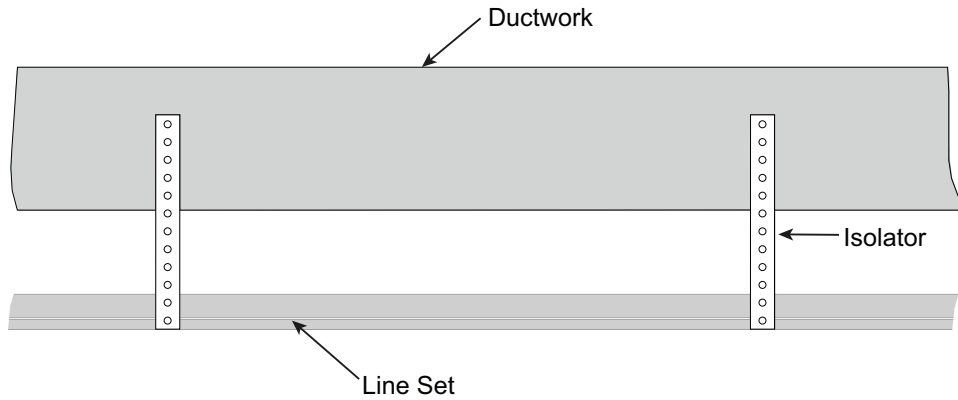

Figure 15. Incorrect lineset installation



Important: Do not hang linesets from ductwork.

Refrigerant Line Brazing

Braze the Refrigerant Lines

1. Remove caps or plugs. Use a deburring tool to deburr the pipe ends. Clean both internal and external surfaces of the tubing using an emery cloth.
2. Remove the pressure tap cap and valve cores from both service valves.
3. Purge the refrigerant lines and indoor coil with dry nitrogen.

Note: A2L equipment shall have red marked service ports and pipes through which refrigerant is serviced.

4. Wrap a wet rag around the valve body to avoid heat damage and continue the dry nitrogen purge.
 - a. Braze the refrigerant lines to the service valves.
 - b. For units shipped with a field-installed external drier, check liquid line filter driers directional flow arrow to confirm correct direction of refrigeration flow (away from outdoor unit and toward evaporator coil) as illustrated. Braze the filter drier to the Liquid Line.
 - c. Continue the dry nitrogen purge. Do not remove the wet rag until all brazing is completed.

Important: Remove the wet rag before stopping the dry nitrogen purge.

Notes:

- Install drier in Liquid Line.
- Precautions should be taken to avoid heat damage to basepan during brazing. It is recommended to keep the flame directly off of the basepan.

5. Replace the pressure tap valve cores and plastic tabs after the service valves have cooled.

Figure 16. Removal of caps or plugs from pipe ends

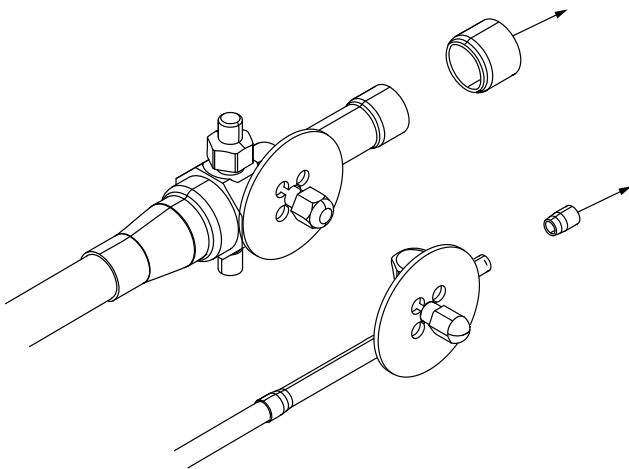

Figure 17. Removal of pressure cap and valve cores from service valves

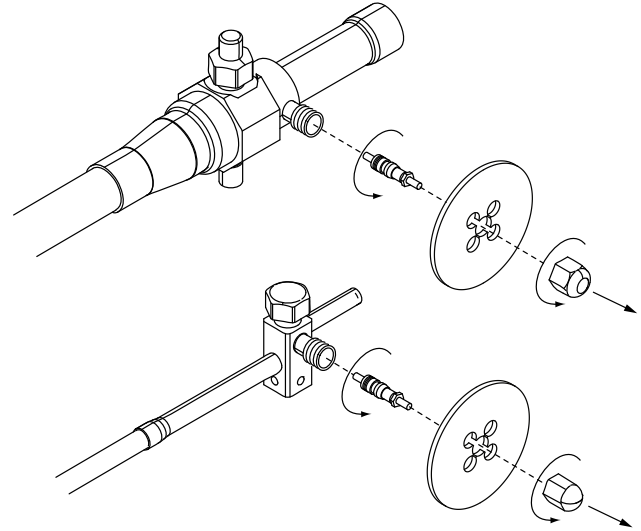

Figure 18. Purging of refrigerant lines

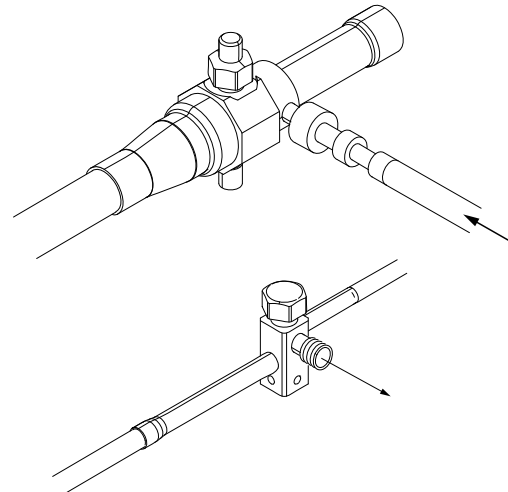



Figure 19. Wrapping of wet rag

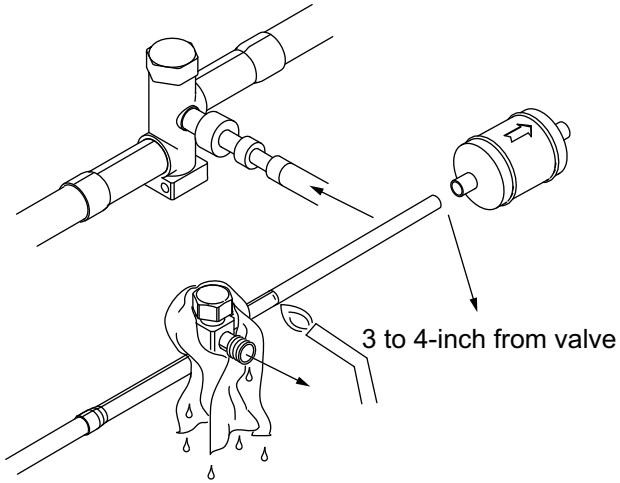
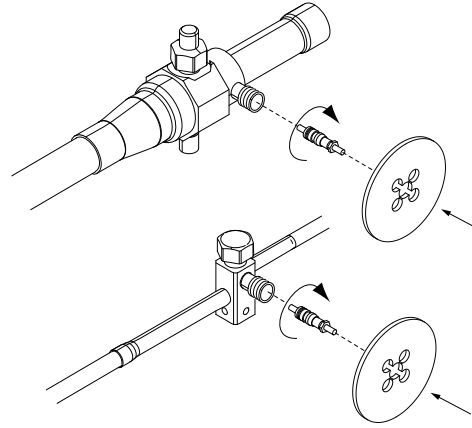

Figure 20. Re-installation of pressure valve cores and plastic tabs



Check for Refrigerant Line Leaks

Important: The outdoor unit should not be tested higher than 450 psig for servicing or component replacement. The indoor unit and linesets should be tested to the max pressure specified on the outdoor or indoor unit nameplate. The service valves should be closed when pressure testing the indoor unit and linesets to separate the outdoor unit from the indoor unit.

1. Isolate the outdoor unit from the indoor unit and linesets using the service valves. Pressurize the indoor unit and linesets to the max pressure specified on the

outdoor or indoor unit nameplate for a minimum of 60 minutes.

Do not add additional refrigerant or test gas after reaching the indoor unit specified pressure. The system should show no loss of pressure once pressurized. Once the pressure test is complete follow the steps for evacuation.

Optional Preliminary Pressure Check – Pressurize the indoor unit and linesets to 150 psig using dry nitrogen.

Figure 21. Example of test and maximum pressure

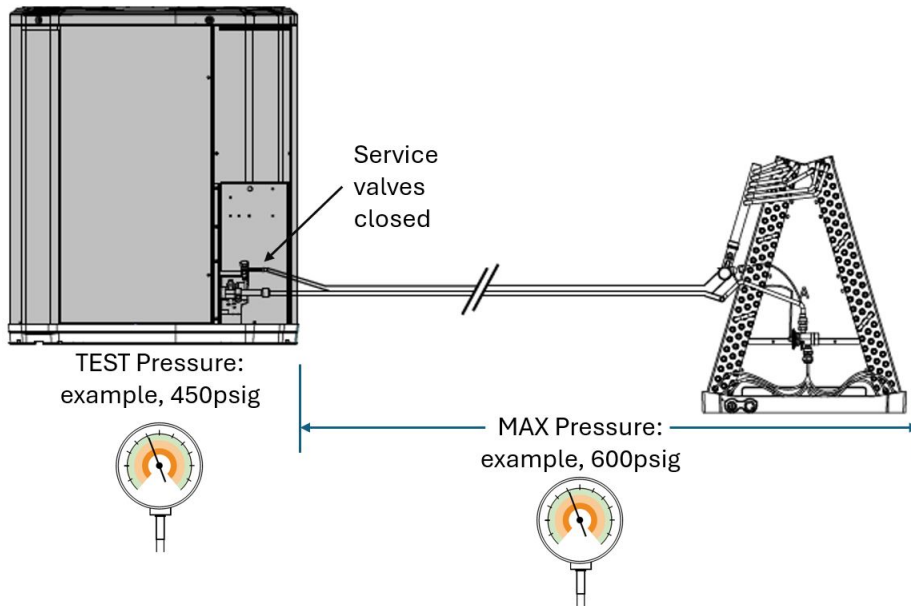

2. Check for leaks by using a soapy solution at each brazed location.

Note: Remove nitrogen pressure and repair any leaks before continuing.

Figure 22. Check for leaks

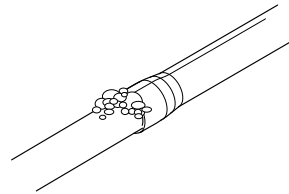

Table 10. Nitrogen purge times

Flow Rate CuFt/Hr	Lineset Length			
	< 50 feet	< 100 feet	< 150 feet	< 200 feet
15	2 minutes	4 minutes	6 minutes	8 minutes
30	1 minute	2 minutes	3 minutes	4 minutes
60	1 minute	1 minute	2 minutes	2 minutes

Evacuation and Servicing

Evacuate the Refrigerant Lines and Indoor Coil

Important: Do not open the service valves until the refrigerant lines and indoor coil leak check and evacuation are complete.

1. Evacuate until the micron gauge reads no higher than 350 microns, then close off the valve to the vacuum pump.

Figure 23. Observe micron gauge reading

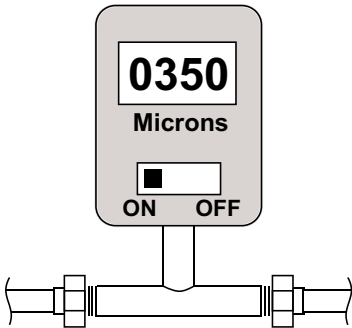

2. Observe the micron gauge. Evacuation is complete, if the micron gauge does not rise above 500 microns in 1 minute and 1500 microns in 10 minutes.

Figure 24. Stopwatch



3. Once evacuation is complete, blank off the vacuum pump and micron gauge, and close the valve on the manifold gauge set.

Servicing

- If repairs must be made after system is charged, properly and safely remove or isolate refrigerant and purge the section of the system needing repair with nitrogen gas or oxygen-free nitrogen prior to opening the circuit.
- The Refrigerant charge shall be recovered into the correctly marked recovery cylinders.

- Ensure that the outlet for the vacuum pump is not close to any potential ignition sources and the ventilation is available.
- Prior to recharging the system, it shall be pressure-tested with the appropriate purging gas. The system shall be leak-tested on completion of charging but prior to commissioning. A follow up leak test shall be carried out prior to leaving the site.
- Ensure that only appropriate refrigerant recovery cylinders are employed. Ensure that the correct number of cylinders for holding the total system charge is available. Only use cylinders designated for the recovered refrigerant and labelled for the refrigerant. Cylinders shall be complete with pressure-relief valve and associated shut-off valves in good working order.
- A set of calibrated weighing scales shall be available and in good working order. Hoses shall be complete with leak-free disconnect couplings and in good condition. Ensure any associated electrical components are sealed.
- The recovered refrigerant shall be returned to the refrigerant supplier in the correct recovery cylinder. Do not mix refrigerants.
- If compressors or compressor oils are to be removed, ensure that they have been evacuated to an acceptable level to make certain that A2L refrigerant does not remain within the lubricant.

Service Valves

Open the Gas Service Valve First

Important: Leak check and evacuation must be completed before opening the service valves.

Note: Do not vent refrigerant gases into the atmosphere.

Service valves can be either Ball or Angle style.

1. Remove valve stem cap.
2. Using an adjustable wrench, turn valve stem 1/4 turn counterclockwise to the fully open position.
3. Replace the valve stem cap to prevent leaks. Tighten finger-tight plus an additional 1/6 turn.

Note: Valves may be ball or angle style.

Figure 25. Gas service valve

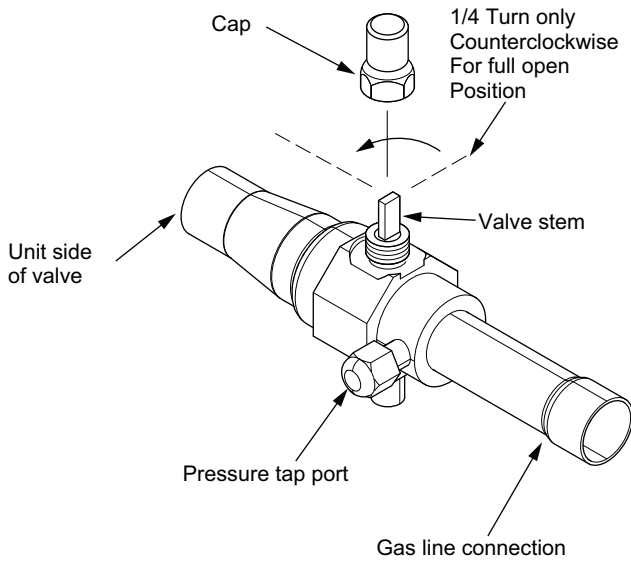

Important: Leak check and evacuation must be completed before opening the service valves.

1. Remove service valve cap.
2. Fully insert a 3/16-inch hex wrench into the stem and back out counterclockwise until valve stem just touches the rolled edge (approximately five turns).
3. Replace the valve cap to prevent leaks. Tighten finger-tight plus an additional 1/6 turn.

Figure 26. Liquid service valve

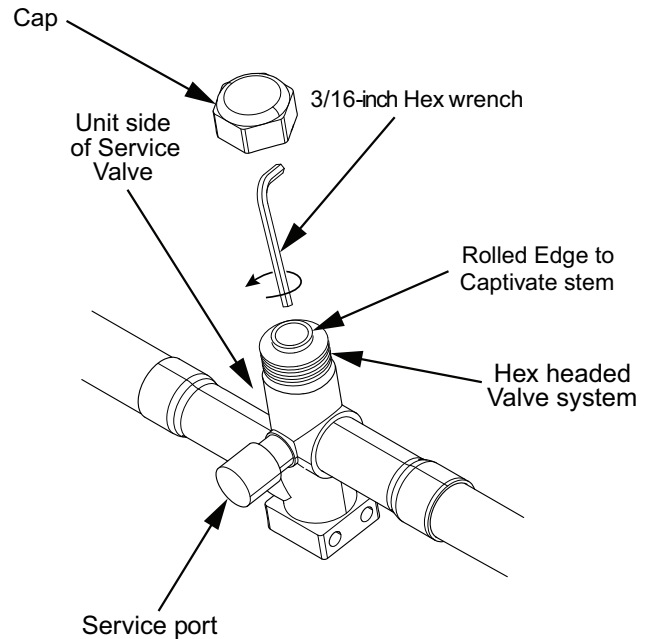

Open the Liquid Service Valve Second

⚠ WARNING

System Charge!

Failure to follow instructions below could result in abrupt release of system charge and could result in serious injury or property damage.

When opening the suction and liquid line service valve, turn the valve stem counterclockwise only until the stem contacts the rolled edge. Do not apply torque.

Electrical – Low Voltage

This table defines the size and combined total maximum length of low voltage wiring from the outdoor unit, to the indoor unit, and to the thermostat.

Notes:

- The use of color coded low voltage wire is recommended to simplify connections between the outdoor unit, the control, and the indoor unit.
- The maximum total cable length for the entire comfort control communicating system is 500 ft. 18 AWG.

Table 11. Control wiring

Wire size	Maximum wire length
18 AWG	500 Feet combined

Control wiring:

- DH and DL wires are required.
- Red and common are not required, although common enhances communication.
- Red and common are required for load shed and SmartCharge™.
- Refer to the Cased Coil MCB Wiring instructions.

Figure 27. Low-voltage hook-up diagrams in Link mode

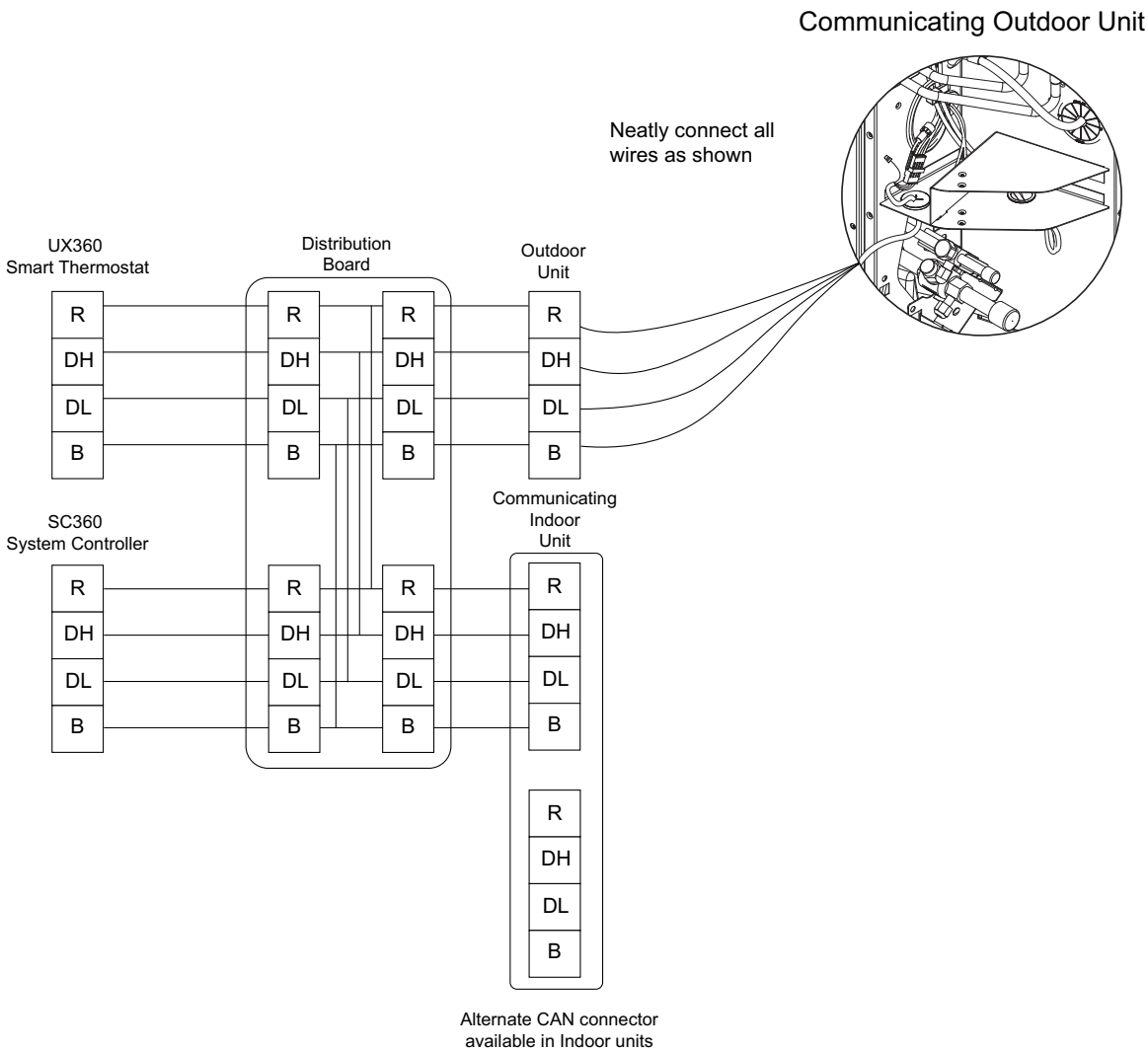

Link Low Voltage Wire Connectors

Link mode uses simple connectors for low voltage connections. These connections are color coded which makes the installation easier and quicker.

Table 12. Link wire colors

R	Red
DH	White
DL	Green
B	Blue

Do the following to make the connections from the actual thermostat wire to the connector.

Note: *These connectors are necessary for the Outdoor unit, Indoor unit and Distribution board.*

1. Strip the Red, White, Green and Blue thermostat wires back 1/4–inch.
2. Insert the wires into the connector in the correctly colored locations.

Figure 28. For use with 18 gauge solid core thermostat wire

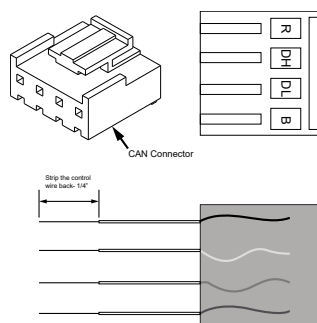

When you feel it release, allow each wire to slide in further.

3. Pull back on the wires individually and slightly and check if the wires are seated properly. If each wire does not pull out for all four wires, the connection is complete.
4. Connectors are **one-time use**. If an 18-gauge thermostat wire breaks inside the connector, the connector will need replaced.
5. Wire colors are for illustration purposes only. If using a different color, ensure it lands at the correct terminal throughout all of the communicating control wiring.

Connect the CAN connector into the male coupling on the low voltage harness at the Outdoor unit.

This indoor unit has two dedicated CAN Connector headers on the Indoor Unit Control Board. In Link communicating mode, both of them are in the communicating loop. It does not matter which one goes to the thermostat, System Controller, distribution board, outdoor unit or any other Link accessory.

Refrigerant Detection System Guidelines

- The approved ID/OD combination will provide sufficient safe ventilation in case of a leak.

- Refer Indoor Unit Installer's Guide for correct specifications on indoor unit install.
- All systems require Refrigerant Detection Systems.
- RDS (Refrigerant Detection System) included in an A2L System.

Electrical – High Voltage

Power Supply

⚠ WARNING

Live Electrical Components!

Failure to follow all electrical safety precautions when exposed to live electrical components could result in death or serious injury.

When it is necessary to work with live electrical components, have a qualified licensed electrician or other individual who has been properly trained in handling live electrical components perform these tasks.

The high voltage power supply must agree with the equipment nameplate.

Power wiring must comply with national, state, and local codes.

Follow instructions on unit wiring diagram located on the inside of the control box cover and in the Installation, Operation, and Maintenance (IOM) document included with the unit.

Figure 29. Nameplate location

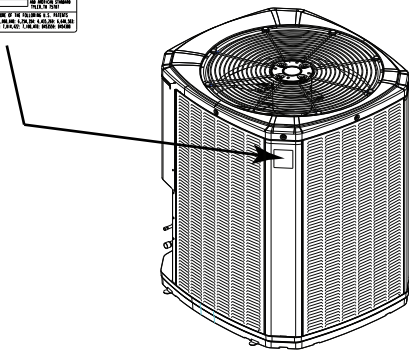
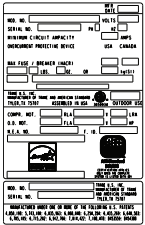

Disconnect Switch

⚠ WARNING

Electrical Shock Hazard!

Failure to follow instructions below could result in death or serious injury or property damage.

Confirm proper grounding before connecting electrical supply.

⚠ WARNING

Hazardous Voltage!

Failure to disconnect power before servicing could result in death or serious injury.

Disconnect all electric power, including remote disconnects before servicing. Follow proper lockout/tagout procedures to ensure the power can not be inadvertently energized. Verify that no power is present with a voltmeter.

Install a separate disconnect switch at the outdoor unit.

For high voltage connections, flexible electrical conduct is recommended whenever vibration transmission may create a noise problem within the structure.

Figure 30. High voltage disconnect switch

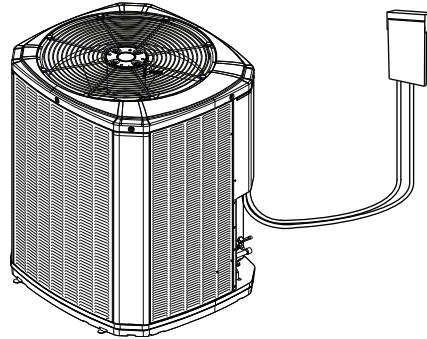

High Voltage Ground

Ground the outdoor unit per national, state, and local code requirements.

Figure 31. Ground symbol

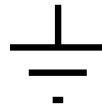

⚠ WARNING

Safety Hazard!

Failure to follow instructions below could result in death or serious injury, and property damage.

Confirm the cabling is protected from wear and tear, corrosion, excessive pressure, vibration, sharp edges, and any other adverse environmental effects.

Integrated Variable Speed Control Board LED Indicators

Figure 32. Control board indicators

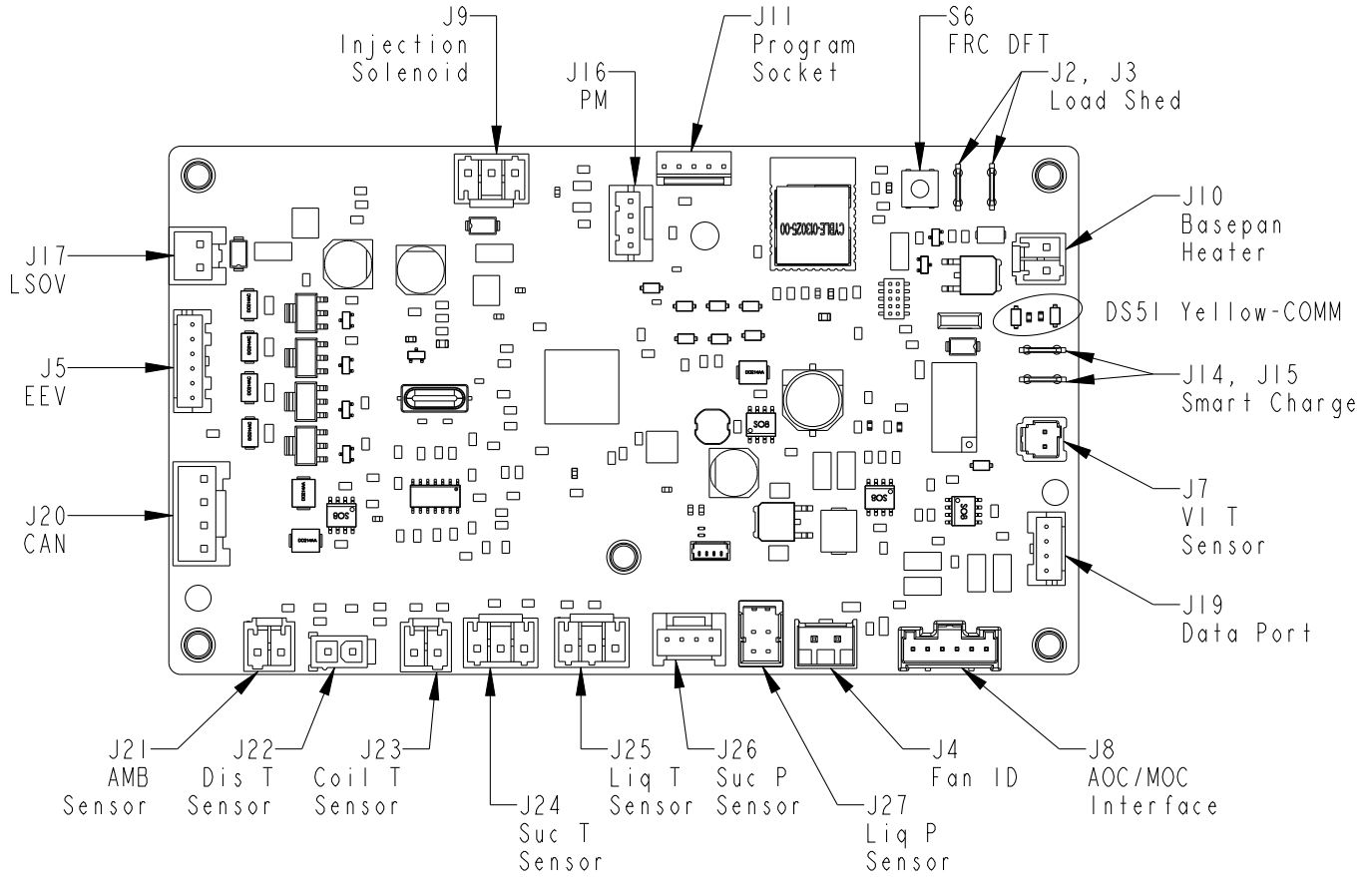

Table 13. LEDs in link mode

LED	Rate	Description	Indication
Comm (amber)	Slow	1 time per device	Device count
	Fast	5 time per second	Loss of communication

Start-up

1. Complete “Refrigerant Line Brazing,” p. 17 through “Electrical – High Voltage,” p. 24.
2. Turn on the disconnect(s) to apply power to the indoor and outdoor units.

Figure 33. Disconnect switch

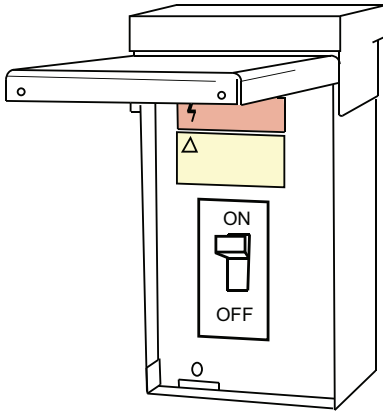

3. Wait three hours before starting the unit if the outdoor ambient temperature is below 85°F.

Figure 34. Wait at three hours before starting the unit



4. Run the system using the “Charging Mode-Cooling” test mode found in the UX360 Smart Thermostat controls. Link systems can also use the Technician Mobile App to enter Test Modes. This is the only approved method for setting the system charge level by subcooling.
Follow the on-screen prompts.



System Charge Adjustment

Temperature Measurements

Subcooling using **Charging Mode-Cooling** is the only recommended method of charging between 55°F and 115°F ambient outdoor temperature.

Use SmartCharge™ Tool (BAYCAKT002) as an optional system charging method. Confirm charge afterward by verifying subcooling.

Figure 35. Outdoor temperatures

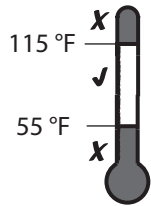

For best results, keep the indoor temperature between 70°F to 80°F.

Figure 36. Indoor temperatures

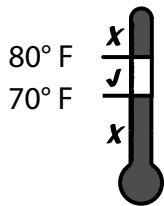

Subcooling Charging Corrections

Determine the final subcooling value using total Line Length and Lift measured in “Required Refrigerant Line Length” and the “Subcooling Charging Corrections Charts”.

Subcooling Charging Correction Worksheet

Total Line Length (ft) _____

Total Vertical Charge (lift) _____

(Values from — Required Refrigerant Line Length)

Design Subcooling Value _____

(from nameplate or Service Facts)

Final Subcooling Value _____

Note: The only mode approved for setting or validating system charge is using Charging Mode-Cooling. Charging Mode-Cooling is a variable speed test mode found in the UX360 comfort control Technician Menu’s. Test modes can also be accessed using the Technician Mobile App. Outdoor Temperature must be between 55°F and 115°F with Indoor Temperature kept between 70°F and 80°F. If starting up in colder conditions, will need to return when the conditions are correct to validate refrigerant charge.

Charging the Unit

1. Attain proper gauge pressure.

Using the standard R-454B subcool charging chart, adjust refrigerant level to attain proper gauge pressure.

Note: Use bubble point, per the included chart, for calculating subcooling.

Add refrigerant if the liquid gauge pressure is lower than the chart value.

- Connect gauges to refrigerant bottle and unit as illustrated.
- Purge all hoses.
- Place refrigerant bottle on a scale and then open bottle.
- Stop adding refrigerant when liquid line refrigerant and liquid gauge pressure match the charging chart.

Notes:

- Recover refrigerant if the liquid gauge pressure is higher than the chart value.
- Verify that contamination of different refrigerants does not occur when using charging equipment. Cylinders shall be kept in an appropriate position according to the instructions. Verify that the refrigeration system is earthed prior to charging the system with refrigerant.

Figure 37. Charging the unit

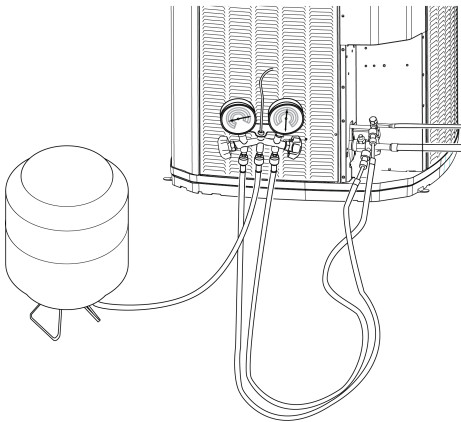

2. Stabilize the system.

- Wait 20 minutes for the system condition to stabilize between adjustments.

Note: When the liquid line temperature and gauge pressure approximately match the chart, the system is properly charged.

- Remove gauges.
- Replace service port caps to prevent leaks. Tighten finger tight plus an additional 1/6 turn.

Figure 38. Stopwatch



- Record system information for reference. Record system pressures and temperatures after charging is complete.

Outdoor model number = _____

Measured Outdoor Ambient = _____ ° F

Measured Indoor Ambient = _____ ° F

Measured Liquid Line Temp = _____ ° F

Measured Suction Line Temp = _____ ° F

Liquid Gauge Pressure = _____ PSI

Suction Gauge Pressure = _____ PSI

- Complete the 'Total System Charge' charge rating label below and label located on the outside of the unit with a permanent marker.

a. Charge added at Factory = _____ lb/oz

b. Charge added at install = _____ lb/oz

c. Total System Charge (a + b) = _____ lb/oz

Subcooling Charging Below 55°F Outdoor Temperature

Initial Install: Weigh-in Method

The subcooling charging method in cooling is not recommended below 55°F outdoor temperature.

The recommended method of charging at outdoor temperatures below 55°F is weighing in the charge. Return when weather conditions permit charge verification through subcooling.

1. Connect low pressure gauge to dedicated metered charge port (see Figure 39, p. 29).

Figure 39. Charge port

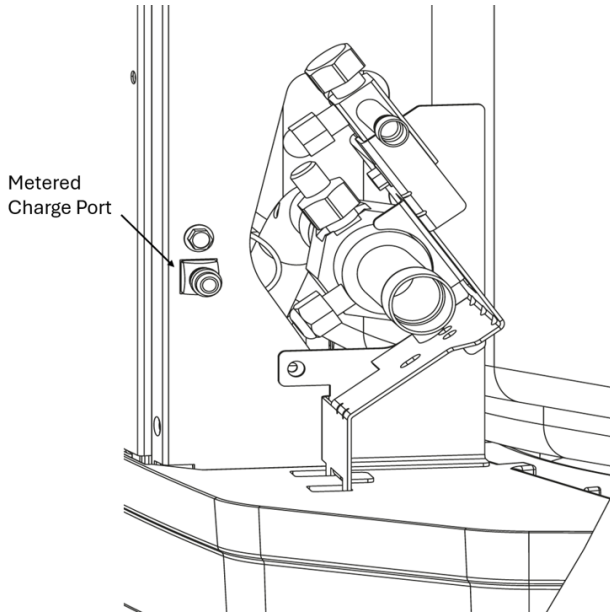

2. Determine additional charge.

Note: The nameplate charge value represents the amount of refrigerant shipped in the outdoor unit and is compatible with 25 feet of AHRI rated refrigerant lines and the smallest AHRI rated coil.

Using the method below, find the charge associated with the additional length of tubing above 25 ft. and record it below.

Weigh-In Method can be used for the initial installation, or anytime a system charge is being replaced. Weigh-In Method can also be used when power is not available to the equipment site or operating conditions (indoor/outdoor temperatures) are not in range to verify with the subcooling charging method.

Calculating charge using the weigh-in method:

- a. Measure in feet the distance between the outdoor unit and the indoor unit and record on Line 1. Include the entire length of the line from the service valve to the IDU (minus 25 ft).
Line length (ft) = _____

- b. Enter the charge multiplier.
Charge multiplier = for 3/8-inch, use 0.47 oz. per foot.
- c. Multiply the total length of refrigerant tubing (Line 1) times the value on .
Record the result on Line 3 of the Worksheet.
Step a x Step b = _____
- d. This is the amount of refrigerant to weigh-in prior to opening the service valves.
Refrigerant = _____

3. If available, refer to “Service: Check Charge Mode – Heating,” p. 30 to verify the charge amount. If not available, stabilize the system by operating for a minimum of 20 minutes in Charge Mode-Heating.
At startup, or whenever charge is removed or added, the system must be operated for a minimum of 20 minutes to stabilize before accurate measurements can be made.

Figure 40. Stopwatch



4. Check the liquid line temperature and liquid gauge pressure to obtain a minimum of 25° subcooling in heating mode.
Measured liquid line temperature = _____ °F
Liquid gauge pressure = _____ PSIG
 5. Add charge if a minimum of 25° subcooling is not obtained with the nameplate charge plus additional charge previously added.
 6. Complete the ‘Total System Charge’ chart rating label below and label located on the outside of the unit with a permanent marker.
- Note:** Complete the ‘Total System Charge’ chart when final charging is complete.
- a. Charge added at factory = _____ lb/oz
 - b. Charge added at install = _____ lb/oz
 - c. Total system charge (a + b) = _____ lb/oz
7. Return to site for adjustment.



Preliminary

Subcooling Charging Below 55°F Outdoor Temperature

Important: Return in the spring or summer to accurately charge the system in the cooling mode with outdoor ambient above 55°F.

Service: Check Charge Mode – Heating

Check charge heating mode targets having enough refrigerant in the system to activate charge management to enable proper heating operation.

Notes:

- Applicable to models with active charge management enabled
- Available from -20°F to 55°F
- All sensors must be functioning properly
- Ensures charge level is appropriate for heating operation
 - Cooling may need to be checked and adjusted when ambient is above 55°F
- Utilizes a metered charging port connected to the common suction (see [Figure 39, p. 29](#))
 - Regulates refrigerant flow into the system to prevent damage
 - Port located on control panel near the gas service valve
- Forced Defrost will stop the test; user must restart test after defrost completes

Figure 41. Flowchart

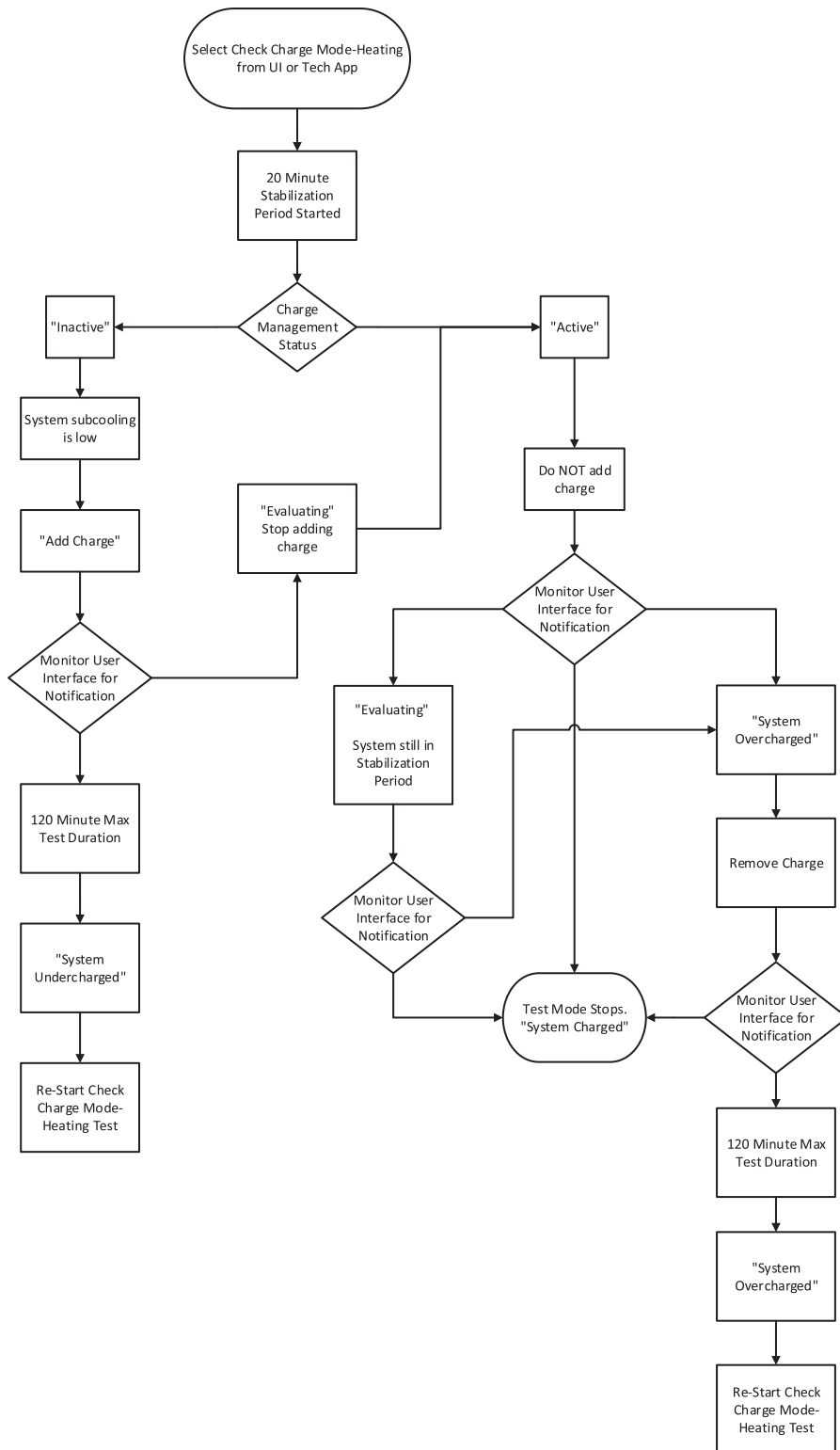



Defrost Control – Heat Pump Only

Note: A forced Defrost test can be entered through the UX360 thermostats or the Link Technician Mobile App.

Demand Defrost

The demand defrost control measures heat pump outdoor ambient temperature with a sensor located outside the outdoor coil. A second sensor located on the outdoor coil is used to measure the coil temperature. The difference between the ambient and the colder coil temperature is the difference or delta-T measurement. This delta-T measurement is representative of the operating state and relative capacity of the heat pump system. By measuring the change in delta-T, we can determine the need for defrost. The coil sensor also serves to sense outdoor coil temperature for termination of the defrost cycle.

Fault Identification

A fault condition is indicated by the UX360 User Interface or Technician Mobile App.

Defrost Enabled

Demand Defrost algorithm uses the following inputs to the AOC:

- Outdoor ambient temperature sensor (ODS)
 - Algorithm-enabled when below 52°F
- Coil temperature sensor (CBS)
 - Algorithm-enabled when below 32°F

Defrost initiates when the difference between OAT and CBS reaches the initiation threshold.

Defrost Initiation

The calculated temperature difference between the outdoor temperature sensor and the coil temperature sensor is called Delta T. Defrost can occur once the current Delta T exceeds the Delta T initiate value. This adaptive logic assures a complete defrost for a range of outdoor temperatures.

Note: A forced Defrost test can be entered through the UX360 thermostats, the outdoor unit AOC or the Link Diagnostic Mobile App.

Figure 42. Defrost termination profiles

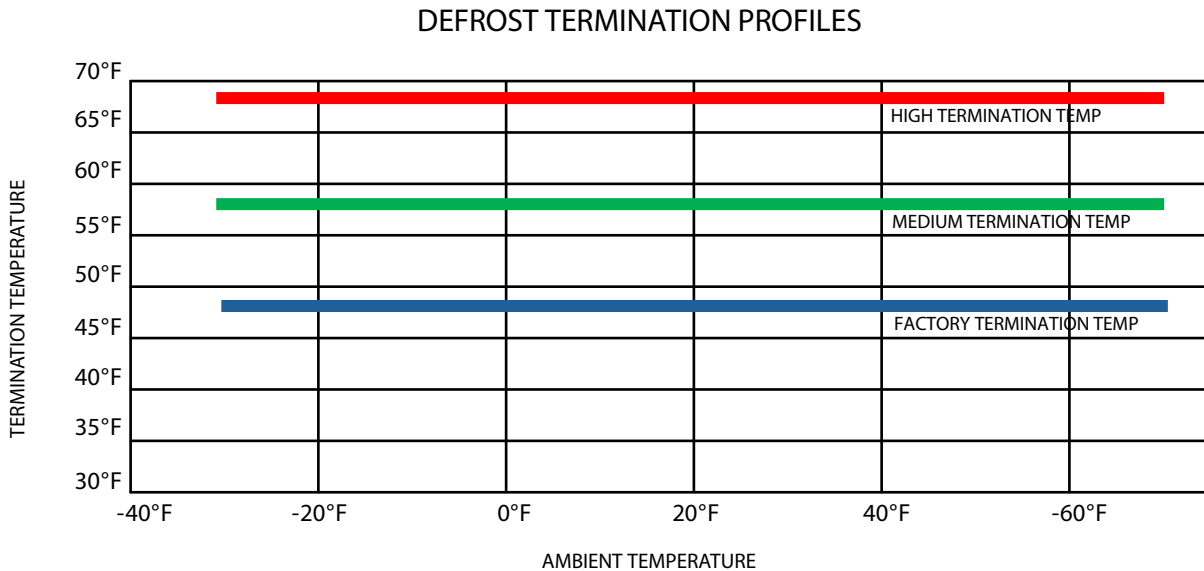

Forced Defrost

1. The system must be running with demand from the thermostat.
 2. FRC DFT TEST can be initiated in heat mode only. DFC TEST can be entered from the UX360 User Interface or Technician Mobile App.
 3. Press ENTER to begin forced defrost.
 4. Execute Forced Defrost following Forced Defrost (Defrost terminates on Coil Temperature or maximum time override of 15 minutes).
 5. When test begins, TEST IN PROGRESS displays and Coil Temperature value.
- Note:** UX360 Home screen will display DEFROST.
6. When test is complete, TEST COMPLETE displays for 10 seconds.

7. If there is a defrost fault condition, test terminates and sends alert to the alert menu.
8. For more information, refer to the Alert Code Tables in Service Facts and Technical Service Manual (34-4301-01 or newer) documents.

Notes:

- *Screens will update as the test proceeds.*
- *Installation, servicing and troubleshooting is done via Technician Access area of the thermostat and/or the Link Technician Mobile App.*
- *Defrost termination temperature can be configured in the "Environment" section of the configuration menu.*

⚠ WARNING

Safety Hazard!

Failure to follow instructions below could result in death or serious injury and equipment or property damage.

- **Do not use any items other than those approved by the manufacturer for defrosting or cleaning process.**
- **Store the appliance in a room without continuously operating ignition sources (for example: open flames, an operating gas appliance, or an operating electric heater).**
- **Do not pierce or burn.**
- **Be cautious that refrigerants may be odorless.**









Checkout Procedures

The final phase of the installation is the system Checkout Procedures. The following list represents the most common items covered in a Checkout Procedure. Confirm all requirements in this document have been met.

- All wiring connections are tight and properly secured.
- Voltage and running current are within limits.
- All refrigerant lines (internal and external to equipment) are isolated, secure, and not in direct contact with each other or structure.
- All braze connections have been checked for leaks. A vacuum of 350 microns provides confirmation that the refrigeration system is leak free and dry. Additional refrigerant weight is recorded on a label by the unit nameplate.
- Final unit inspection to confirm factory tubing has not shifted during shipment. Adjust tubing if necessary so tubes do not rub against each other or any component when unit runs.
- Ductwork is sealed and insulated.
- All drain lines are clear with joints properly sealed. Pour water into drain pan to confirm proper drainage. Provide enough water to ensure drain trap is primed.
- Supply registers and return grilles are open, unobstructed, and air filter is installed.
- Indoor blower and outdoor fan are operating smoothly and without obstruction.
- Indoor airflow configured for desired comfort or efficiency in UX360 Control Configuration Section in Technician Access Area. For most efficient operation (including any CVP testing), select "More Efficient" in Compressor Heating and Cooling.
- Verify blower and fan set screws are tight.
- Cover panels are in place and properly tightened.
- System functions safely and properly in all modes.
- Owner has been instructed on use of system and given manual.
- Verify that the Refrigerant Leak Detection system is operational.
- Verify that the refrigerant quantity is marked on the unit.

Symbols

Figure 43. Hazard symbols

	<p>[symbol ISO 7010-W021 (2011-05)]</p>	<p>warning; flammable materials</p>
	<p>[symbol ISO 7000-1659 (2004-01)]</p>	<p>service indicator; read technical manual</p>
	<p>A2L symbol</p>	<p>warning; low burning velocity material</p>
	<p>[symbol ISO 7000-1701 (2004-01)]</p>	<p>pressure</p>
	<p>[symbol IEC 60417-6040 (2010-08)]</p>	<p>ultraviolet radiation, instructional safeguard</p>
	<p>[symbol ISO 7000-1641 (2004-01)]</p>	<p>operator's manual; operating instructions</p>

	<p>Refrigerant class per ISO 817</p>
---	--------------------------------------



Notices

FCC Notice

Contains FCC ID: WAP3025

This device complies with part 15 of the FCC Rules. Operation is subject to the following two conditions: (1) This device may not cause harmful interference, and (2) this device must accept any interference received, including interference that may cause undesired operation. The antenna(s) used for this transmitter must be installed to provide a separation distance of at least 20 cm from all persons and must not be collocated or operating in conjunction with any other antenna or transmitter. This equipment has been tested and found to comply with the limits for Class B Digital Device, pursuant to Part 15 of the FCC Rules. These limits are designed to provide reasonable protection against harmful interference in a residential installation. This equipment generates and can radiate radio frequency energy and, if not installed and used in accordance with the instructions, may cause harmful interference to radio communications. However, there is no guarantee that interference will not occur in a particular installation. If this equipment does cause harmful interference to radio or television reception, which can be determined by turning the equipment off and on, the user is encouraged to try to correct the interference by one or more of the following measures.

- Reorient or relocate the receiving antenna

- Increase the separation between the equipment and receiver
- Connect the equipment into an outlet on a circuit different from that to which the receiver is connected
- Consult the dealer or an experienced radio/TV technician for help

Any changes or modifications not expressly approved by the party responsible for compliance could void the user's authority to operate the equipment.

IC Notice

Contains IC ID: 7922A-3025

This device complies with Industry Canada license exempt RSS standard(s). Operation is subject to the following two conditions: (1) this device may not cause interference, and (2) this device must accept any interference, including interference that may cause undesired operation of the device.

Le présent appareil est conforme aux CNR d'Industrie Canada applicables aux appareils radio exempts de licence. L'exploitation est autorisée aux deux conditions suivantes: (1) l'appareil ne doit pas produire de brouillage, et (2) l'utilisateur de l'appareil doit accepter tout brouillage radioélectrique subi, même si le brouillage est susceptible d'en compromettre le fonctionnement.

Preliminary

Preliminary



Trane - by Trane Technologies (NYSE: TT), a global innovator - creates comfortable, energy efficient indoor environments for commercial and residential applications. For more information, please visit trane.com or tranetechnologies.com.



The AHRI Certified mark indicates Trane U.S. Inc. participation in the AHRI Certification program. For verification of individual certified products, go to ahridirectory.org.

Trane has a policy of continuous data improvement and it reserves the right to change design and specifications without notice. We are committed to using environmentally conscious print practices.