



# Installer's Guide

## Multi-Speed Heat Pumps and Air Conditioners Featuring ComfortSeek™

5TWR7024A  
5TWR7036A  
5TWR7048A  
5TWR7060A

5TTR7024A  
5TTR7036A  
5TTR7048A  
5TTR7060A

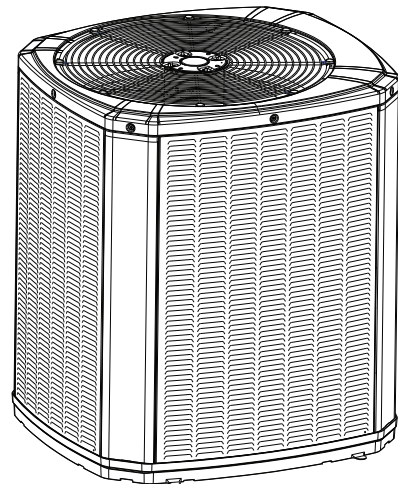

*Note: Graphics in this document are for representation only.  
Actual model may differ in appearance.*

### **⚠ SAFETY WARNING**

Only qualified personnel should install and service the equipment. The installation, starting up, and servicing of heating, ventilating, and air-conditioning equipment can be hazardous and requires specific knowledge and training. Improperly installed, adjusted or altered equipment by an unqualified person could result in death or serious injury. When working on the equipment, observe all precautions in the literature and on the tags, stickers, and labels that are attached to the equipment.



# Introduction

Read this manual thoroughly before operating or servicing this unit.

This document is customer property and is to remain with this unit. Return to the service information pack upon completion of work.

**Note:** See AHRI directory for approved indoor and outdoor model combinations. Only Trane coils and air handlers are approved for use with multi-speed outdoor unit.

**Table 1. Operating Range**

Mode	Model	Operating Range
Cooling	2 – 5 Ton	55 °F – 120°F
Heating	2 – 5 Ton	0° F – 66°F

## Warnings, Cautions, and Notices

Safety advisories appear throughout this manual as required. Your personal safety and the proper operation of this machine depend upon the strict observance of these precautions.

The three types of advisories are defined as follows:

- WARNING** Indicates a potentially hazardous situation which, if not avoided, could result in death or serious injury.
- CAUTION** Indicates a potentially hazardous situation which, if not avoided, could result in minor or moderate injury. It could also be used to alert against unsafe practices.
- NOTICE** Indicates a situation that could result in equipment or property-damage only accidents.

## Important Environmental Concerns

Scientific research has shown that certain man-made chemicals can affect the earth's naturally occurring stratospheric ozone layer when released to the atmosphere. In particular, several of the identified chemicals that may affect the ozone layer are refrigerants that contain Chlorine, Fluorine and Carbon (CFCs) and those containing Hydrogen, Chlorine, Fluorine and Carbon (HCFCs). Not all refrigerants containing these compounds have the same potential impact to the environment. Trane advocates the responsible handling of all refrigerants.

## Important Responsible Refrigerant Practices

Trane believes that responsible refrigerant practices are important to the environment, our customers, and the air conditioning industry. All technicians who handle refrigerants must be certified according to local rules. For the USA, the Federal Clean Air Act (Section 608) sets forth the requirements for handling, reclaiming, recovering and recycling of certain refrigerants and the equipment that is used in these service procedures. In addition, some states

or municipalities may have additional requirements that must also be adhered to for responsible management of refrigerants. Know the applicable laws and follow them.

**WARNING**

**Proper Field Wiring and Grounding Required!**

Failure to follow code could result in death or serious injury.

All field wiring **MUST** be performed by qualified personnel. Improperly installed and grounded field wiring poses **FIRE** and **ELECTROCUTION** hazards. To avoid these hazards, you **MUST** follow requirements for field wiring installation and grounding as described in NEC and your local/state/national electrical codes.

**WARNING**

**Personal Protective Equipment (PPE) Required!**

Failure to wear proper PPE for the job being undertaken could result in death or serious injury.

Technicians, in order to protect themselves from potential electrical, mechanical, and chemical hazards, **MUST** follow precautions in this manual and on the tags, stickers, and labels, as well as the instructions below:

- Before installing/servicing this unit, technicians **MUST** put on all PPE required for the work being undertaken (Examples; cut resistant gloves/sleeves, butyl gloves, safety glasses, hard hat/bump cap, fall protection, electrical PPE and arc flash clothing). **ALWAYS** refer to appropriate Safety Data Sheets (SDS) and OSHA guidelines for proper PPE.
- When working with or around hazardous chemicals, **ALWAYS** refer to the appropriate SDS and OSHA/GHS (Global Harmonized System of Classification and Labelling of Chemicals) guidelines for information on allowable personal exposure levels, proper respiratory protection and handling instructions.
- If there is a risk of energized electrical contact, arc, or flash, technicians **MUST** put on all PPE in accordance with OSHA, NFPA 70E, or other country-specific requirements for arc flash protection, **PRIOR** to servicing the unit. **NEVER PERFORM ANY SWITCHING, DISCONNECTING, OR VOLTAGE TESTING WITHOUT PROPER ELECTRICAL PPE AND ARC FLASH CLOTHING. ENSURE ELECTRICAL METERS AND EQUIPMENT ARE PROPERLY RATED FOR INTENDED VOLTAGE.**

**⚠ WARNING****Follow EHS Policies!**

Failure to follow instructions below could result in death or serious injury.

- All Trane personnel must follow the company's Environmental, Health and Safety (EHS) policies when performing work such as hot work, electrical, fall protection, lockout/tagout, refrigerant handling, etc. Where local regulations are more stringent than these policies, those regulations supersede these policies.
- Non-Trane personnel should always follow local regulations.

**⚠ WARNING****Cancer and Reproductive Harm!**

This product can expose you to chemicals, including lead, which are known to the State of California to cause cancer and birth defects or other reproductive harm. For more information go to [www.P65Warnings.ca.gov](http://www.P65Warnings.ca.gov).

**⚠ WARNING****Safety Hazard!**

Failure to follow instructions below could result in death or serious injury or property damage.

This unit is not to be used by persons (including children) with reduced physical, sensory, or mental capabilities, or lack of experience and knowledge, unless they have been given supervision or instruction concerning the use of the appliance by a person responsible for their safety.

Do not allow children to play or climb on the unit or to clean or maintain the unit without supervision.

**⚠ WARNING****Hazardous Voltage!**

Failure to disconnect power before servicing could result in death or serious injury.

Disconnect all electric power, including remote disconnects before servicing. Follow proper lockout/tagout procedures to ensure the power can not be inadvertently energized. Verify that no power is present with a voltmeter.

**⚠ WARNING****R-454B Refrigerant!**

Failure to use proper equipment or components as described below could result in death, serious injury, or equipment damage.

- Use ONLY R-454B rated service equipment with these units.
- All R-454B systems with variable speed compressors use variable speed compressor oil, which absorbs moisture from the air. To limit this hygroscopic action, keep the system sealed. If exposed to air for over 4 hours, replace the compressor oil.
- Never break a vacuum with air and always replace driers when opening the system to replace components.

**⚠ WARNING****Hot Surface!**

Failure to follow instructions below could result in minor to severe burns.

Do not touch top of compressor. It may be hot.

**⚠ WARNING****Refrigerant under High Pressure!**

Failure to follow instructions below could result in an explosion which could result in death or serious injury or equipment damage.

System contains oil and refrigerant under high pressure. Recover refrigerant to relieve pressure before opening the system. See unit nameplate for refrigerant type. Do not use non-approved refrigerants, refrigerant substitutes, or refrigerant additives.

**⚠ WARNING****Grounding Required!**

Failure to follow instructions below could result in death or serious injury, or property damage.

- Reconnect all grounding devices.
- All parts of this product that are capable of conducting electrical current are grounded.
- If grounding wires, screws, straps, clips, nuts, or washers used to complete a path to ground are removed for service, they must be returned to their original position and properly fastened.

**⚠ WARNING****System Charge!**

Failure to follow instructions below could result in abrupt release of system charge and could result in serious injury or property damage.

When opening the suction and liquid line service valve, turn the valve stem counterclockwise only until the stem contacts the rolled edge. Do not apply torque.

**⚠ WARNING****Electrical Shock Hazard!**

Failure to follow instructions below could result in death or serious injury or property damage. Confirm proper grounding before connecting electrical supply.

**⚠ WARNING****Risk of Fire — Flammable Refrigerant!**

Failure to follow instructions below could result in death or serious injury, and equipment damage.

- To be repaired only by trained service personnel.
- Do not puncture refrigerant tubing.
- Dispose of properly in accordance with federal or local regulations.

**⚠ WARNING****Ventilation Required!**

Failure to follow instructions below could result in death or serious injury or property damage. Confirm the area is adequately ventilated before breaking into the system or conducting any hot work.

**⚠ CAUTION****Caution!**

Failure to follow instructions below could result in minor to moderate injury or equipment damage.

- For brazing, confirm all joints are brazed, not soldered.
- For mechanical connections, confirm a negative leak test.
- Inspect lines and use proper service tools.

**NOTICE****Equipment Damage!**

Failure to follow instructions below could result in equipment damage.

Use only R-454B rated indoor models, service equipment, and components with these units.

**⚠ WARNING****Electrical Hazard!**

Failure to follow instructions below could result in death or personal injury.

**WAIT TWO (2) MINUTES** after disconnecting power prior to touching electrical components as they may hold a dangerous charge of 400 VDC. Then verify DC Voltage is less than 42 VDC at inverter test points labeled +DC and -DC before servicing board.

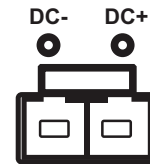
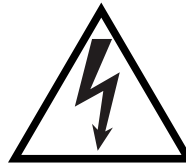
**Copyright**

This document and the information in it are the property of Trane, and may not be used or reproduced in whole or in part without written permission. Trane reserves the right to revise this publication at any time, and to make changes to its content without obligation to notify any person of such revision or change.

**Trademark**

All trademarks referenced in this document are the trademarks of their respective owners.

**Revision History**

Updated the Integrated Variable Speed Control Board LED Indicators (A1000BA Models) chapter.



# Table of Contents

Unit Location Considerations . . . . .	6	High Voltage Disconnect Switch . . . . .	23
Piping Guidelines . . . . .	6	High Voltage Ground . . . . .	23
R-454B Refrigerant Charging Chart . . . . .	9	Integrated Variable Speed Control Board	
Refrigerant Properties . . . . .	9	LED Indicators . . . . .	24
Suggested Locations for Best		Start-Up . . . . .	29
Reliability . . . . .	11	System Charge Adjustment . . . . .	30
Cold Climate Considerations (Heat		Temperature Measurements . . . . .	30
Pump Only) . . . . .	11	Subcooling Charging Corrections . . . . .	30
Coastal Considerations . . . . .	11	Charging the Unit . . . . .	31
Unit Preparation . . . . .	12	Proper Gauge Pressure . . . . .	31
Setting Up the Unit . . . . .	12	Stabilize the System . . . . .	31
Refrigerant Line Considerations . . . . .	13	System Information . . . . .	31
Factory Charge . . . . .	13	Total System Charge . . . . .	31
Required Refrigerant Line Length . . . . .	13	Charging Below 55° F Outdoor	
Refrigerant Line Insulation . . . . .	13	Temperature in Heating Mode . . . . .	32
Reuse Existing Refrigerant Lines . . . . .	13	Determine Additional Charge . . . . .	32
Refrigerant Line Routing Precautions . . . . .	14	Stabilize the System . . . . .	32
Refrigerant Line Brazing . . . . .	15	Complete the Total System Charge	
Refrigerant Line Leak Check . . . . .	17	Chart . . . . .	32
Refrigerant Line and Indoor Coil		Return to Site for Adjustment . . . . .	32
Evacuation . . . . .	18	Defrost Control (Heat Pump only) . . . . .	33
Servicing . . . . .	18	Demand Defrost . . . . .	33
Service Valves . . . . .	20	Fault Identification . . . . .	33
Open the Gas/Vapor Service Valve		Defrost Enabled . . . . .	33
First . . . . .	20	Defrost Initiation . . . . .	33
Open the Liquid Service Valve Second . . . . .	20	Forced Defrost . . . . .	33
Electrical – Low Voltage		Checkout Procedures . . . . .	34
Communicating . . . . .	21	Symbols . . . . .	35
Refrigerant Detection System		Notices . . . . .	36
Guidelines . . . . .	22		
Electrical – High Voltage . . . . .	23		
High Voltage Power Supply . . . . .	23		



# Unit Location Considerations

## Piping Guidelines

Piping material, pipe routing, and installation shall include protection from physical damage in operation and service, and be in compliance with national and local codes and standards. All field joints shall be accessible for inspection prior to being covered or enclosed. Install of pipe work shall be kept to a minimum. That provisions shall be made for expansion and contraction of long runs of piping.

**Table 2. Dimensions and weights**

Models	H x D x W (in.)	Weight <sup>(a)</sup> (lb)
5TWR7024A	41 x 30 x 33	181
5TWR7036A	41 x 30 x 33	194
5TWR7048A	41 x 34 x 37	231
5TWR7060A	41 x 34 x 37	241
5TTR7024A	41 x 30 x 33	176
5TTR7036A	41 x 30 x 33	189
5TTR7048A	41 x 34 x 37	226
5TTR7060A	41 x 34 x 37	236

**Notes:**

1. When mounting the outdoor unit on a roof, be sure the roof will support the unit's weight.
2. Properly selected isolation is recommended to alleviate sound or vibration transmission to the building structure.

<sup>(a)</sup> Weight values are estimated (uncrated).

**Figure 1. Dimensions**

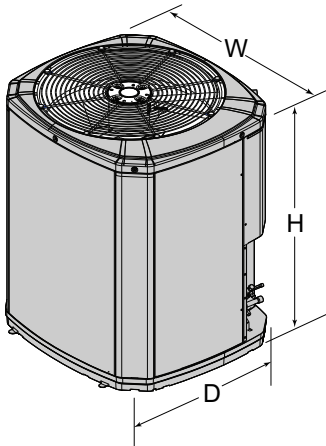

**Table 3. Refrigerant line and service valve connection sizes**

Model	Rated Line Sizes (in.)		Service Valve Connection Sizes (in.)	
	Vapor Line	Liquid Line	Vapor Line Connection	Liquid Line Connection
5TWR7024A	3/4 <sup>(a)</sup> , <sup>(b)</sup>	5/16	3/4	5/16
5TWR7036A	3/4 <sup>(a)</sup> , <sup>(b)</sup>	5/16	3/4	5/16

**Table 3. Refrigerant line and service valve connection sizes (continued)**

Model	Rated Line Sizes (in.)		Service Valve Connection Sizes (in.)	
	Vapor Line	Liquid Line	Vapor Line Connection	Liquid Line Connection
5TWR7048A	7/8 <sup>(a)</sup> , <sup>(b)</sup>	5/16	7/8	5/16
5TWR7060A	7/8 <sup>(a)</sup> , <sup>(b)</sup>	3/8	7/8	3/8
5TTR7024A	3/4 <sup>(a)</sup> , <sup>(b)</sup>	5/16	3/4	5/16
5TTR7036A	3/4 <sup>(a)</sup> , <sup>(b)</sup>	5/16	3/4	5/16
5TTR7048A	7/8 <sup>(a)</sup> , <sup>(b)</sup>	5/16	7/8	5/16
5TTR7060A	7/8 <sup>(a)</sup> , <sup>(b)</sup>	3/8	7/8	3/8

<sup>(a)</sup> For max length of refrigerant lines from outdoor to indoor unit see Table 4.

<sup>(b)</sup> Select correct line set size in set up app. Default is set to alternate line sizes.

**Figure 2. Line length**

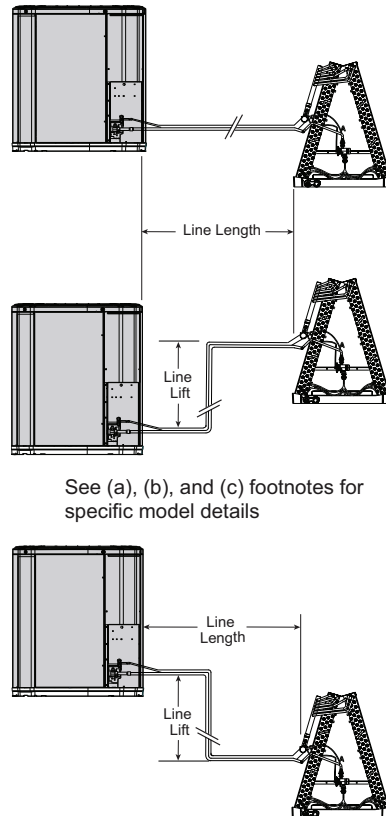

**Note:** The following tables are general estimates. for more accurate and up-to-date lineset recommendations, use the Piping Program.

**Table 4. 2 and 3 ton lineset sizes and length**

Vapor Line	Liquid Line	Length	Lift
1/2	5/16	100	50
5/8	5/16	150	50
3/4	5/16	100	50
1/2	3/8	100	50
5/8	3/8	150	50
3/4	3/8	100	50
<b>Note:</b>			
Ratings/Primary			
Legacy Lineset			
Smallest Allowed			

**Table 5. 2 ton AC (HP) subcooling adders**

Diameter	2 Ton AC (HP) Subcooling Adders									
	Liquid	ft	10	20	30	40	50	100	125	150
5/16	50						0	0	2	2
	40					0	0	0	2	2
	30				0	0	0	0	0	0
	20			0	0	0	0	0	0	0
	10	0	0	0	0	0	0	0	0	0
	0	0	0	0	0	0	0	0	0	0

**Note:** 3/8-inch line sizes do not require any additional subcool adders.

**Table 6. 3 ton AC (HP) subcooling adders**

Diameter	3 Ton AC (HP) Subcooling Adders									
	Liquid	ft	10	20	30	40	50	100	125	150
5/16	50						0	0	2	2
	40					0	0	0	2	2
	30				0	0	0	0	0	0
	20			0	0	0	0	0	0	0
	10	0	0	0	0	0	0	0	0	0
	0	0	0	0	0	0	0	0	0	0

**Note:** 3/8-inch line sizes do not require any additional subcool adders.

**Table 7. 4 ton lineset sizes and length**

Vapor Line	Liquid Line	Length	Lift
5/8	5/16	100	25
3/4	5/16	100	25
7/8	5/16	100	25
5/8	3/8	100	25
3/4	3/8	150	25
7/8	3/8	150	25



## Unit Location Considerations

**Table 7. 4 ton lineset sizes and length (continued)**

Vapor Line	Liquid Line	Length	Lift
<b>Note:</b>			
Ratings/Primary			
Legacy Lineset			
Smallest Allowed			

**Table 8. 4 ton AC (HP) subcooling adders**

Diameter	4 Ton AC (HP) Subcooling Adders								
Liquid	ft	10	20	30	40	50	100	90	100
5/16	50					0	0*3/8		
	40					0	0*3/8		
	30			0	0	0	0	0*3/8	0*3/8
	20		0	0	0	0	0	0	0
	10	0	0	0	0	0	0	0	0
	0	0	0	0	0	0	0	0	0

**Note:** 3/8-inch line sizes do not require any additional subcool adders.

**Table 9. 5 ton lineset sizes and length**

Vapor Line	Liquid Line	Length	Lift
5/8	5/16	100	25
3/4	5/16	100	25
7/8	5/16	100	25
5/8	3/8	100	50
3/4	3/8	150	25
7/8	3/8	150	25
<b>Note:</b>			
Ratings/Primary			
Legacy Lineset			
Smallest Allowed			

**Table 10. 5 ton AC (HP) subcooling adders**

Diameter	5 Ton AC (HP) Subcooling Adders								
Liquid	ft	10	20	30	40	50	100	125	150
3/8	50					0	2		
	40					0	2		
	30			0	0	0	0	2	2
	20		0	0	0	0	0	0	0
	10	0	0	0	0	0	0	0	0
	0	0	0	0	0	0	0	0	0

**Note:** 3/8-inch line sizes do not require any additional subcool adders.

**Table 11. Alternate refrigerant line and service valve connection sizes**

Model	Alternate Line Sizes (in.)		Service Valve Connection Sizes (in.)	
	Vapor Line	Liquid Line	Vapor Line Connection	Liquid Line Connection
5TWR7024A	1/2, 5/8 <sup>(a)</sup>	3/8	3/4	5/16
5TWR7036A	1/2, 5/8 <sup>(a)</sup>	3/8	3/4	5/16
5TWR7048A	5/8, 3/4 <sup>(a)</sup>	3/8	7/8	5/16
5TWR7060A	5/8, 3/4 <sup>(a)</sup>	5/16	7/8	3/8
5TTR7024A	1/2, 5/8 <sup>(a)</sup>	3/8	3/4	5/16
5TTR7036A	1/2, 5/8 <sup>(a)</sup>	3/8	5/8	5/16
5TTR7048A	5/8, 3/4 <sup>(a)</sup>	3/8	3/4	5/16
5TTR7060A	5/8, 3/4 <sup>(a)</sup>	5/16	3/4	3/8

<sup>(a)</sup> For max length of refrigerant lines from outdoor to indoor unit see Table 4.

## R-454B Refrigerant Charging Chart

**Table 12. Refrigerant charging**

Liquid temp (f)	Design subcooling (f)						
	8	9	10	11	12	13	14
	Liquid gauge pressure (psig)						
55	170	172	175	178	181	184	187
60	184	187	190	194	197	200	203
65	200	203	206	210	213	217	220
70	217	220	223	227	230	234	238
75	234	238	241	245	249	252	256
80	252	256	260	264	268	272	276
85	272	276	280	284	288	292	297
90	292	297	301	305	309	314	318
95	314	318	323	327	332	336	341
100	336	341	346	351	355	360	365
105	360	365	370	375	380	385	390
110	385	390	396	401	406	412	417
115	412	417	422	428	433	439	445
120	439	445	450	456	462	468	474
125	468	474	480	486	492	498	504

**Note:** When charging to Subcooling values, use Bubble Temp chart. If referencing Superheat, use Dew Point chart.

## Refrigerant Properties

**Table 13. Refrigerant properties**

Pgauge (psig)	Superheat Dew Table (°F)	Subcooling Bubble Table (°F)
30	-12	-14
35	-7	-9
40	-2	-4
45	2	0
50	6	4
55	10	7
60	13	11
65	17	14
70	20	18
75	23	21
80	26	24
85	29	26

**Table 13. Refrigerant properties (continued)**

Pgauge (psig)	Superheat Dew Table (°F)	Subcooling Bubble Table (°F)
90	31	29
95	34	32
100	37	34
105	39	37
110	41	39
115	44	41
120	46	44
125	48	46
130	50	48
135	52	50
140	54	52
145	56	54
150	58	56
155	60	58



## Unit Location Considerations

**Table 13. Refrigerant properties (continued)**

Pgauge (psig)	Superheat Dew Table (°F)	Subcooling Bubble Table (°F)
160	62	60
165	64	61
170	66	63
175	67	65
180	69	67
185	71	68
190	72	70
195	74	71
200	75	73
205	77	75
210	78	76
215	80	78
220	81	79
225	83	80
230	84	82
235	86	83
240	87	85
245	88	86
250	90	87
255	91	89
260	92	90
265	94	91
270	95	93
275	96	94
280	97	95
285	99	96
290	100	97
295	101	99
300	102	100
305	103	101
310	104	102
315	106	103
320	107	104
325	108	105
330	109	107
335	110	108
340	111	109
345	112	110
350	113	111

**Table 13. Refrigerant properties (continued)**

Pgauge (psig)	Superheat Dew Table (°F)	Subcooling Bubble Table (°F)
355	114	112
360	115	113
365	116	114
370	117	115
375	118	116
380	119	117
385	120	118
390	121	119
395	122	120
400	123	121
405	124	122
410	125	123
415	126	124
420	127	125
425	128	125
430	128	126
435	129	127
440	130	128
445	131	129
450	132	130
455	133	131
460	134	132
465	134	132
470	135	133
475	136	134
480	137	135
485	138	136
490	139	137
495	139	137
500	140	138
505	141	139
510	142	140
515	143	141
520	143	141
525	144	142
530	145	143
535	146	144
540	146	145

**Table 13. Refrigerant properties (continued)**

Pgauge (psig)	Superheat Dew Table (°F)	Subcooling Bubble Table (°F)
545	147	145
550	148	146

### Suggested Locations for Best Reliability

- Confirm the top discharge area is unrestricted for at least 5 feet above the unit.
- Provide at least 3 feet clearance in front of the control box (access panels) and any other side requiring service.
- Do not locate close to bedrooms as operational sounds may be objectionable.
- Avoid locations near windows and similar areas where condensation and freezing defrost vapor can annoy a customer.
- Position the outdoor unit a minimum of 12 inches from any wall or surrounding shrubbery to ensure adequate airflow.
- Outdoor unit location must be far enough away from any structure to prevent excess roof runoff water or icicles from falling directly on the unit.

**Figure 3. Location considerations**

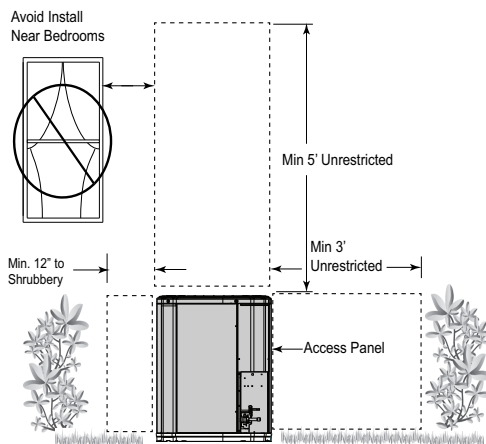

- Position the outdoor unit a minimum of 12 inches from any wall or surrounding shrubbery to ensure adequate airflow.
- Outdoor unit location must be far enough away from any structure to prevent excess roof runoff water or icicles from falling directly on the unit.

**Figure 4. Location considerations**

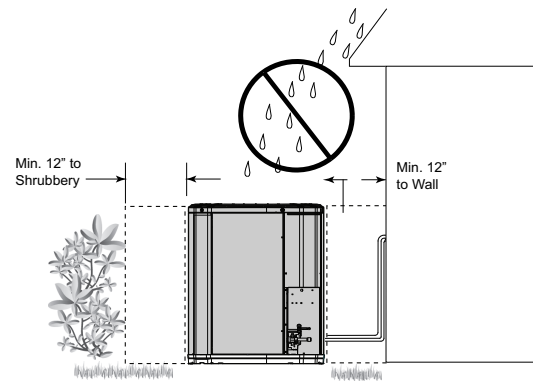

### Cold Climate Considerations (Heat Pump Only)

**Note:** It is recommended that these precautions be taken for units being installed in areas where snow accumulation and prolonged below-freezing temperatures occur.

- Units should be elevated 3 to 12 inches above the pad or rooftop, depending on local weather. This additional height will allow drainage of snow and ice melted during defrost cycle prior to its refreezing. Ensure that drain holes in unit base pan are not obstructed, preventing drainage of defrost water.
- If possible, avoid locations that are likely to accumulate snow drifts. If not possible, a snow drift barrier should be installed around the unit to prevent a build-up of snow on the sides of the unit.

**Figure 5. Cold climate considerations**

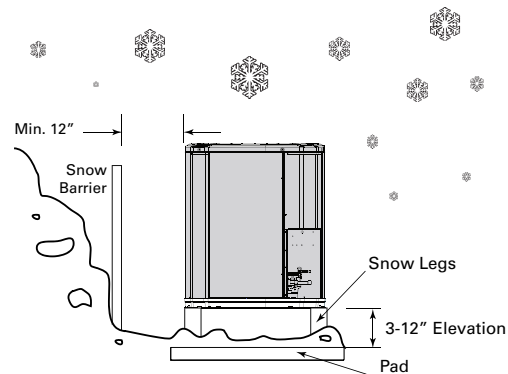

### Coastal Considerations

If installed within one mile of salt water, including seacoasts and inland waterways, models without factory supplied Seacoast Salt Shields require the addition of BAYSEAC001 (Seacoast Kit) at installation time.

## Unit Preparation

1. Check for damage and report promptly to the carrier any damage found to the unit.

**Figure 6. Damaged unit**

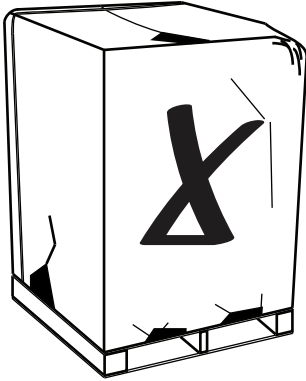

2. To remove the unit from the pallet, remove tabs by cutting with a sharp tool.

**Figure 7. Remove the tabs**

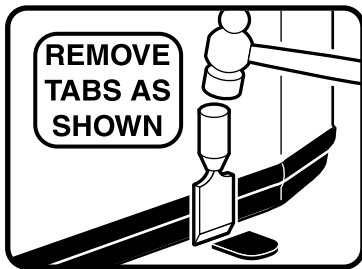

## Setting Up the Unit

When installing the unit on a support pad, such as a concrete slab, consider the following:

- The pad should be at least one inch larger than the unit on all sides.
- The pad must be separate from any structure.
- The pad must be level.
- The pad should be high enough above grade to allow for drainage.
- The pad location must comply with National, State, and Local codes.

**Figure 8. Pad installation**

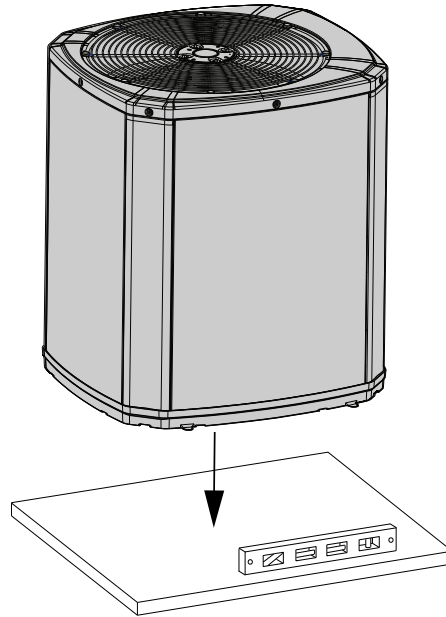

# Refrigerant Line Considerations

## Factory Charge

The outdoor condensing units are factory charged with the system charge required for the outdoor condensing unit, ten (10) feet of tested connecting line, and the smallest rated indoor evaporative coil match. Always verify proper system charge via subcooling (TXV/EEV).

## Required Refrigerant Line Length

Determine required line length and lift. You will need this to determine the subcooling charging corrections later in the installation process.

Total Line Length = \_\_\_\_\_ Ft.

Total Vertical Change (lift) = \_\_\_\_\_ Ft.

Figure 9. Line length

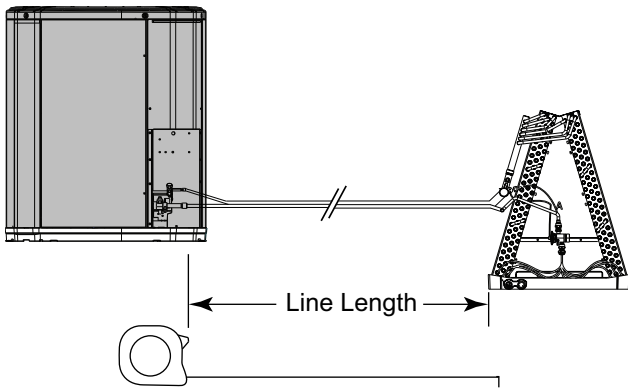

## Refrigerant Line Insulation

**Important:** The Vapor Line must always be insulated. DO NOT allow the Liquid Line and Vapor Line to come in direct (metal to metal) contact.

**Note:** The Vapor Line must always be insulated. Insulating the liquid line through attic spaces may benefit system performance by minimizing heat gain in the liquid line.

Figure 10. Refrigerant line insulation

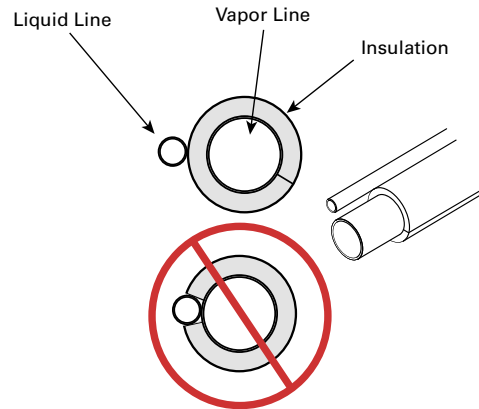

## Reuse Existing Refrigerant Lines

### ⚠ CAUTION

#### Brazed Joints!

Failure to follow instructions below could result in minor to moderate injury or equipment damage. When using existing refrigerant lines, verify all joints are brazed and not soldered.

For retrofit applications, where the existing indoor evaporator coil and/or refrigerant lines will be used, the following precautions should be taken.

- Ensure that the indoor evaporator coil and refrigerant lines are the correct size.
- Ensure that the refrigerant lines are free of leaks, acid, and oil.

**Important:** For more information, see publication number *Refrigerant Piping Manual for Small Split Cooling and Heat Pump Systems - Application Guide (SS-APG006\*-EN)*.

Figure 11. Refrigerant line example

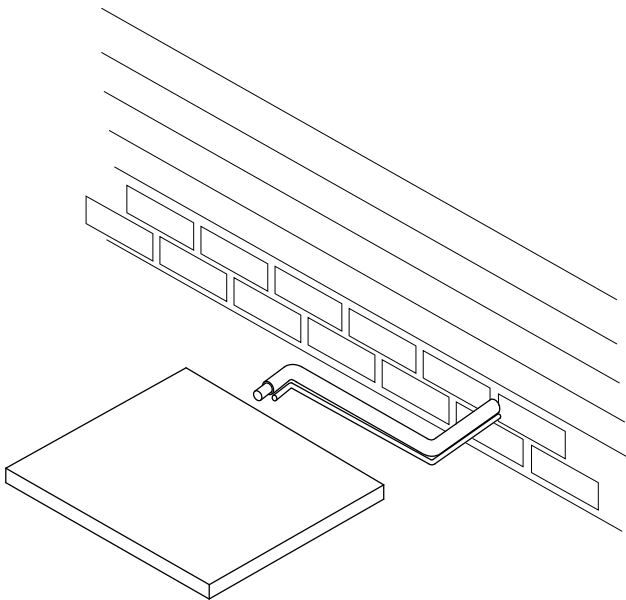

## Refrigerant Line Routing Precautions

**Important:**

- Comply with National, State, and Local Codes when isolating line sets from joists, rafters, walls, or other structural elements.
- For buried linesets, see publication *Refrigerant Piping Manual for Small Split Cooling and Heat Pump Systems - Application Guide (SS-APG006\*-EN)*.
- Take precautions to prevent noise within the building structure due to vibration transmission from the refrigerant lines.

For example:

- When the refrigerant lines must be fastened to floor joists or other framing in a structure, use isolation type hangers.
- Isolation hangers should also be used when refrigerant lines are run in stud spaces or enclosed ceilings.
- Where the refrigerant lines run through a wall, sill or enclosed ceiling- they should be insulated, isolated and serviceable if any braze connections are present.
- Isolate the lines from all duct work.
- Minimize the number of 90° turns.

Figure 12. Isolation in wall spaces

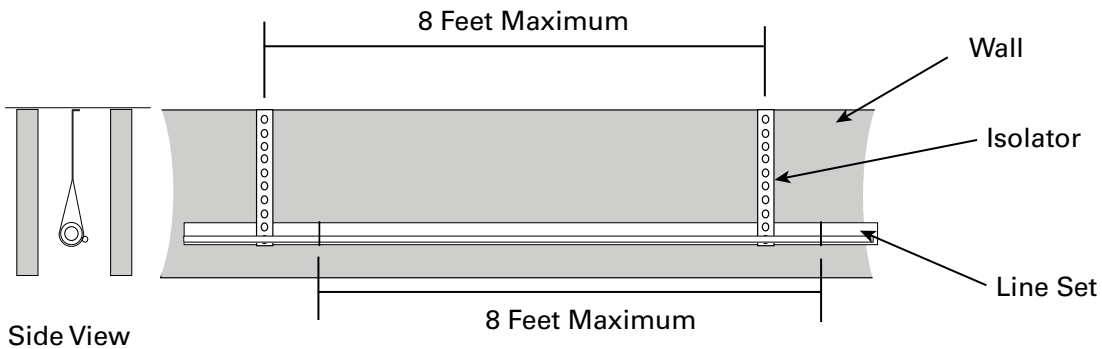

Figure 13. Isolation through the wall

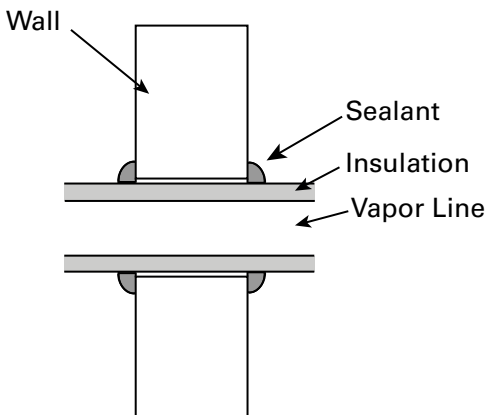
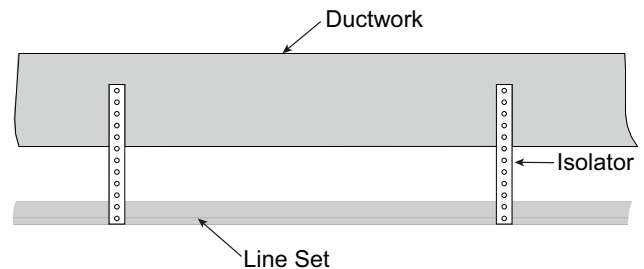

Figure 14. Incorrect lineset installation



# Refrigerant Line Brazing

To braise the refrigerant lines:

1. Remove caps or plugs.

**Figure 15. Remove caps**

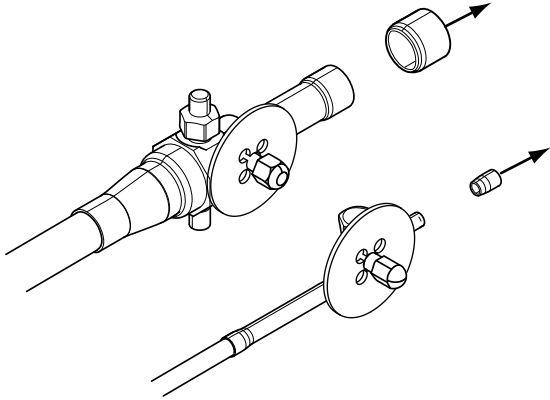

2. Use a deburring tool to deburr the pipe ends.
3. Clean both internal and external surfaces of the tubing using an emery cloth.

Remove the pressure tap cap, plastic tab, and valve core from each service valves.

**Figure 16. Remove pressure tap cap, plastic tab, and valve**

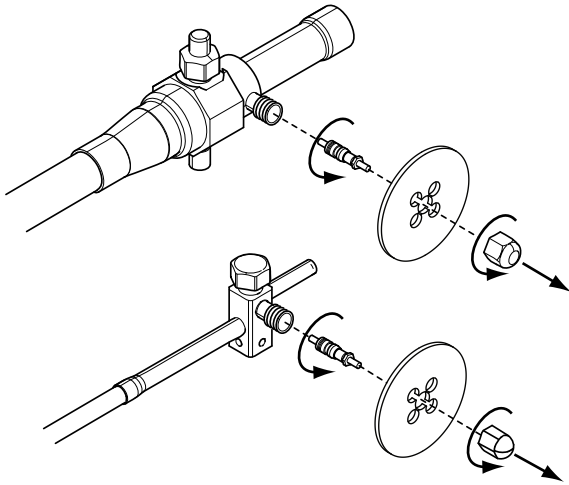

4. Purge the refrigerant lines and indoor coil with dry nitrogen.

**Note:** A2L equipment shall have red marked service ports and pipes through which refrigerant is serviced.

**Figure 17. Purge valves**

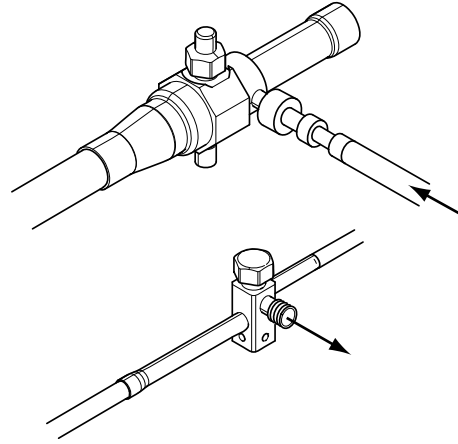

5. Wrap a wet rag around the valve body to avoid heat damage and continue the dry nitrogen purge.

**Figure 18. Wrap a wet rag around the valve body**

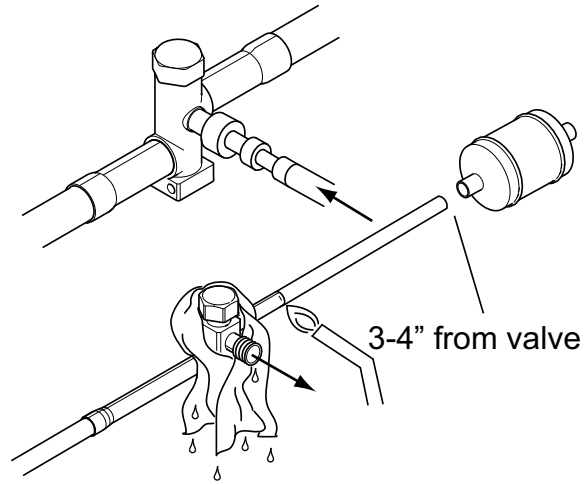

6. Braze the refrigerant lines to the service valves. For Units shipped with a field-installed external drier, check liquid line filter drier's directional flow arrow to confirm correct direction of refrigeration flow (away from outdoor unit and toward evaporator coil) as illustrated. Braze the filter drier to the Liquid Line.
7. Continue the dry nitrogen purge. Do not remove the wet rag until all brazing is completed.

**Important:** Remove the wet rag before stopping the dry nitrogen purge.

**Note:** Precautions should be taken to avoid heat damage to base pan during brazing. It is recommended to keep the flame directly off of the base pan.

8. Replace the pressure tap valve cores and plastic tabs after the service valves have cooled.

## Refrigerant Line Brazing

---

Figure 19. Replace pressure tap valve cores and plastic tabs

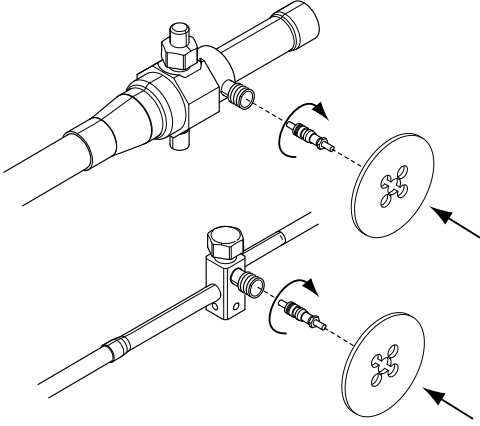

# Refrigerant Line Leak Check

**Important:** The outdoor unit should not be tested higher than 450 PSIG for servicing or component replacement. The indoor unit and linesets should be tested to the max pressure specified on the outdoor or indoor unit nameplate. The service valves should be closed when pressure testing the indoor unit and linesets to separate the outdoor unit from the indoor unit.

1. Perform a final pressure check:
  - a. Isolate the outdoor unit from the indoor unit and linesets using the service valves.

- b. Pressurize the indoor unit and linesets to the max pressure specified on the outdoor or indoor unit nameplate for a minimum of 60 minutes. Do not add additional refrigerant or test gas after reaching the indoor unit specified pressure. The system should show no loss of pressure once pressurized.
- c. Once the pressure test is complete follow the steps for evacuation.

Optional (Preliminary Pressure Check) - Pressurize the indoor unit and linesets to 150 PSIG using dry nitrogen.

**Figure 20. Pressure check**

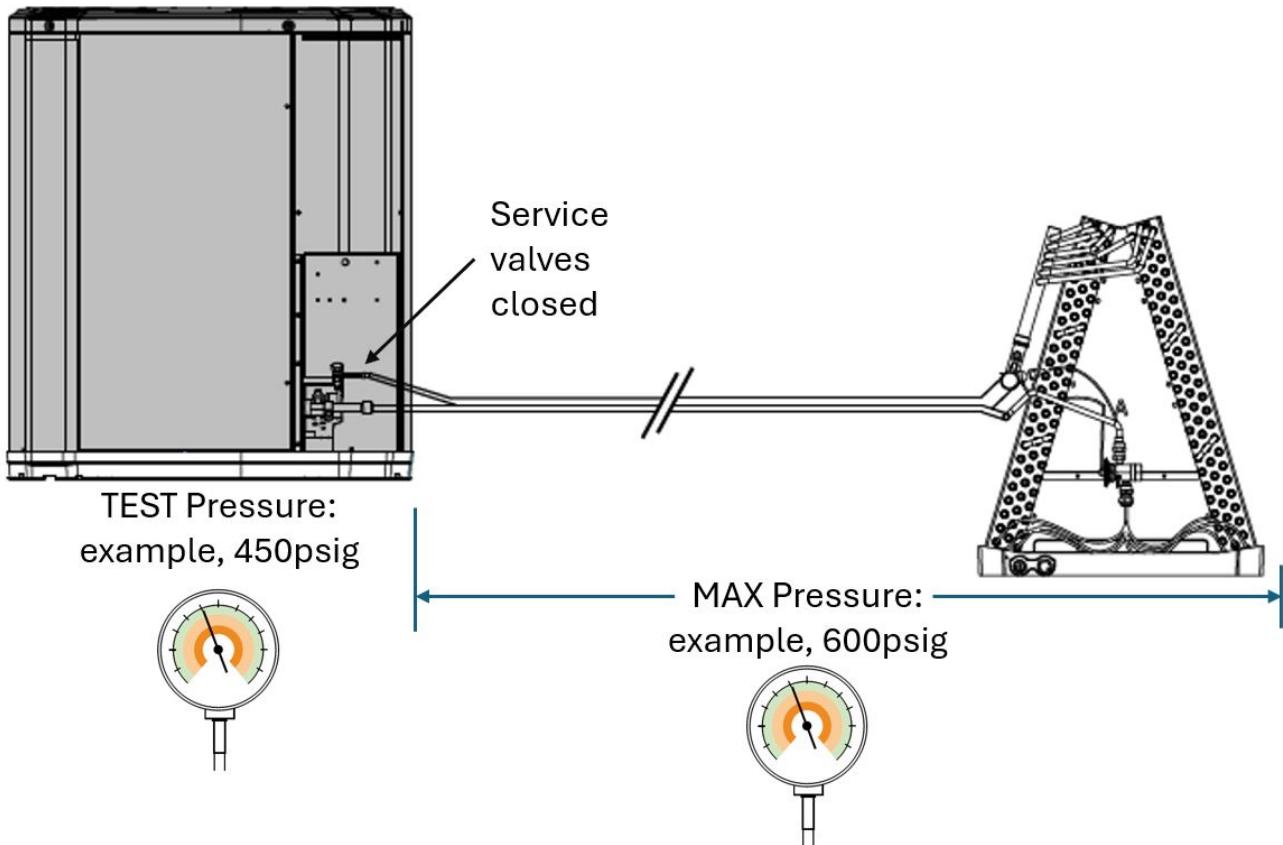

2. Check for leaks by using a soapy solution at each brazed location.

**Note:** Remove nitrogen pressure and repair any leaks before continuing.

**Figure 21. Check for leaks**

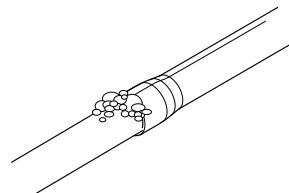



## Refrigerant Line Leak Check

Table 14. Nitrogen purge times

Flow Rate	Lineset Length			
	< 50 feet	< 100 feet	< 150 feet	< 200 feet
CuFt/Hr				
15	2 Minutes	4 Minutes	6 Minutes	8 Minutes
30	1 Minute	2 Minutes	3 Minutes	4 Minutes
60	1 Minute	1 Minute	2 Minutes	2 Minutes

## Refrigerant Line and Indoor Coil Evacuation

**Important:** Do not open the service valves until the refrigerant lines and indoor coil leak check and evacuation are complete.

1. Evacuate until the micron gauge reads no higher than 350 microns, then close off the valve to the vacuum pump.

Figure 22. Observe micron gauge reading

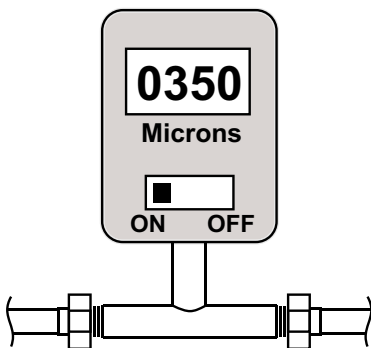

2. Observe the micron gauge. Evacuation is complete if the micron gauge does not rise above 1500 microns in ten (10) minutes.

Figure 23. Wait 10 minutes



3. When evacuation is complete, blank off the vacuum pump and micron gauge, and close the valves on the manifold gauge set.

Under no circumstances shall potential sources of ignition be used in the searching for or detection of refrigerant leaks.

The following leak detection methods are deemed acceptable for all refrigerant systems:

- Electronic leak detectors calibrated for R-454B
- Bubble method

If a leakage of refrigerant is found which requires brazing, all of the refrigerant shall be recovered from the system, or isolated (by means of shut off valves) in a part of the system remote from the leak.

## Servicing

When servicing:

- The area shall be checked with an appropriate refrigerant detector prior to and during work, to ensure the technician is aware of potentially toxic or flammable atmospheres.
- Ensure that the leak detection equipment being used is suitable for use with all applicable refrigerants, i.e. non-sparking, adequately sealed or intrinsically safe.
- Work shall be undertaken under a controlled procedure so as to minimise the risk of a flammable gas or vapor being present while the work is being performed.
- If any hot work is to be conducted on the refrigerating equipment or any associated parts, appropriate fire extinguishing equipment shall be available to hand.
- Have a dry powder or CO<sub>2</sub> fire extinguisher adjacent to the servicing area.
- Ensure that the area is in the open or that it is adequately ventilated before breaking into the system or conducting any hot work.
- A degree of ventilation shall continue during the period that the work is carried out. The ventilation should safely disperse any released refrigerant and preferably expel it externally into the atmosphere.

### Important:

1. The following leak detection methods are deemed acceptable for all refrigerant systems:
  - a. Electronic leak detectors calibrated for R-454B
  - b. Bubble method
2. Under no circumstances shall potential sources of ignition be used in the searching for or detection of refrigerant leaks.

- If a leak is suspected, all naked flames shall be removed/extinguished.

## Refrigerant Line Leak Check

- If a leakage of refrigerant is found which requires brazing, all of the refrigerant shall be recovered from the system, or isolated (by means of shut off valves) in a part of the system remote from the leak.
- If repairs must be made after system is charged, properly and safely remove or isolate refrigerant and purge the section of the system needing repair with inert gas or oxygen free nitrogen prior to opening the circuit.
- The refrigerant charge shall be recovered into the correctly marked recovery cylinders. Ensure that the outlet for the vacuum pump is not close to any potential ignition sources and that ventilation is available.

**Table 15. Nitrogen purge times**

Flow Rate	Lineset Length			
CuFT/Hr	< 50 feet	< 100 feet	< 150 feet	< 200 feet
15	2 Minutes	4 Minutes	6 Minutes	8 Minutes
30	1 Minute	2 Minutes	3 Minutes	4 Minutes
60	1 Minute	1 Minute	2 Minutes	2 Minutes

- Confirm that only appropriate refrigerant recovery cylinders are employed. Ensure that the correct number of cylinders for holding the total system charge is available. Only use cylinders designated for the recovered refrigerant and labelled for that refrigerant. Cylinders shall be complete with pressure-relief valve and associated shut-off valves in good working order.
  - A calibrated weighing scale shall be available and in good working order. Hoses shall be complete with leak-free disconnect couplings and in good condition.
- Ensure any associated electrical components are sealed.
- The recovered refrigerant shall be returned to the refrigerant supplier in the correct recovery cylinder. Do not mix refrigerants.
  - If compressors or compressor oils are to be removed, ensure that they have been evacuated to an acceptable level to make certain that A2L refrigerant does not remain within the lubricant.

# Service Valves

## Open the Gas/Vapor Service Valve First

**Important:** Leak check and evacuation must be completed before opening the service valves.

**Note:** Do not vent refrigerant gases into the atmosphere.

1. Remove valve stem cap.
2. Using a wrench, turn valve stem 1/4 turn counterclockwise to the fully open position.
3. Replace the valve stem cap to prevent leaks. Tighten finger tight plus an additional 1/4 turn.

**Figure 24. Gas/vapor service valve**

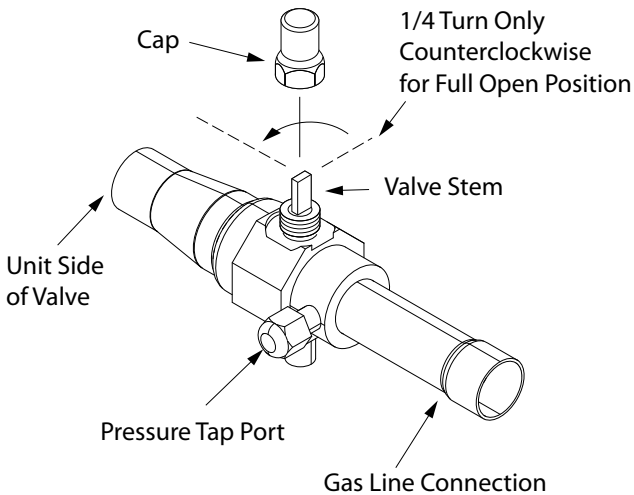

**Notes:**

- Valve caps need to be brass or locking style.
- Opening the Vapor service valve first ensures the compressor oil stays in the compressor at start-up.
- Service valves may be ball or angle style.

## Open the Liquid Service Valve Second

**⚠ WARNING**

**System Charge!**  
 Failure to follow instructions below could result in abrupt release of system charge and could result in serious injury or property damage.  
**When opening the suction and liquid line service valve, turn the valve stem counterclockwise only until the stem contacts the rolled edge. Do not apply torque.**

**Important:** Leak check and evacuation must be completed before opening the service valves.

1. Remove service valve cap.
2. Fully insert 3/16-inch hex wrench into the stem and back out counterclockwise until valve stem just touches the rolled edge (approximately five (5) turns).
3. Replace the valve cap to prevent leaks. Tighten finger tight plus an additional 1/4 turn.

**Figure 25. Liquid service valve**

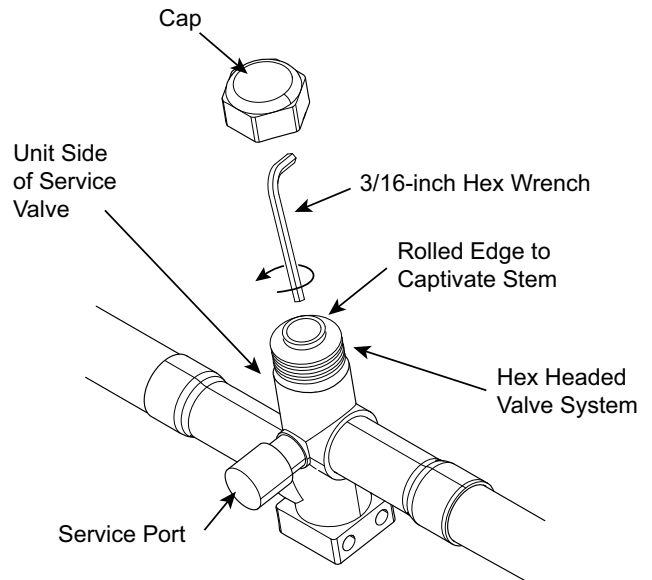



# Electrical – Low Voltage Communicating

The following table defines the size and combined total maximum length of low voltage wiring from the outdoor unit, to the indoor unit, and to the thermostat.

**Note:** The use of color coded low voltage wire is recommended to simplify connections between the outdoor unit, the control, and the indoor unit.

**Table 16. Low voltage maximum wire length**

Control wiring	
Wire size	Maximum Wire length
18 AWG	500 ft combined

**Figure 26. Connection diagrams – 5STEM4, 5TAM5**

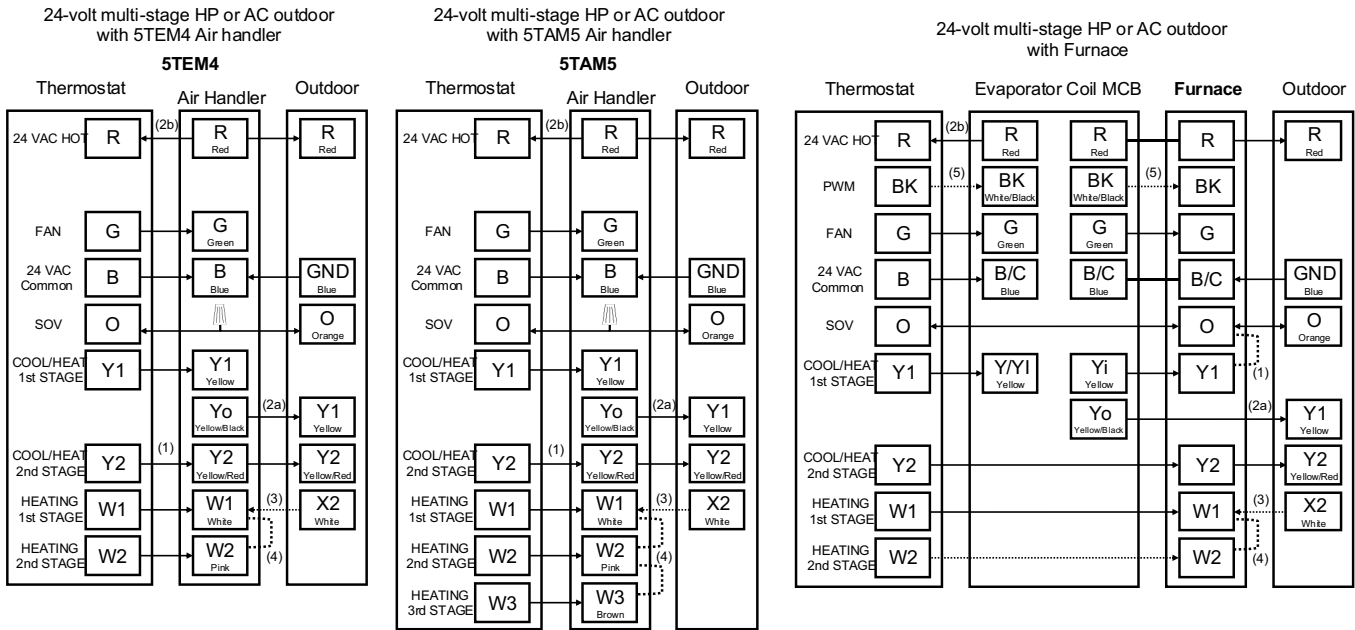

1. Separate Y1 and Y2 at air handler. Remove Y1-O jumper on furnace board with heat pump.
2. Condensate switch, float switch, leak detector, etc. installation options:
  - a. Break Y1 to the outdoor so the outdoor shuts down but the indoor blower continues to run.
  - b. Break R to the thermostat so the entire system shuts down.
3. Do not wire X2 with select Trane thermostats, defrost is communicated to the thermostat via the O signal.
4. Do not jump W terminals together with select Trane thermostats, high stage heat is automatically called during defrost.
5. For BK functionality with select Trane thermostats: Cut BK jumper at the furnace board and connect BK.

**Notes:**

- BK dehumidification reduces indoor airflow when active.
- HP models require R and O at the outdoor. AC models do not require O at the outdoor.
- Use wire nuts for all pigtail connections and cap all unused wires.

**Figure 27. Connection diagrams – 5TEM6, 5TEMC, and 5TAMX**

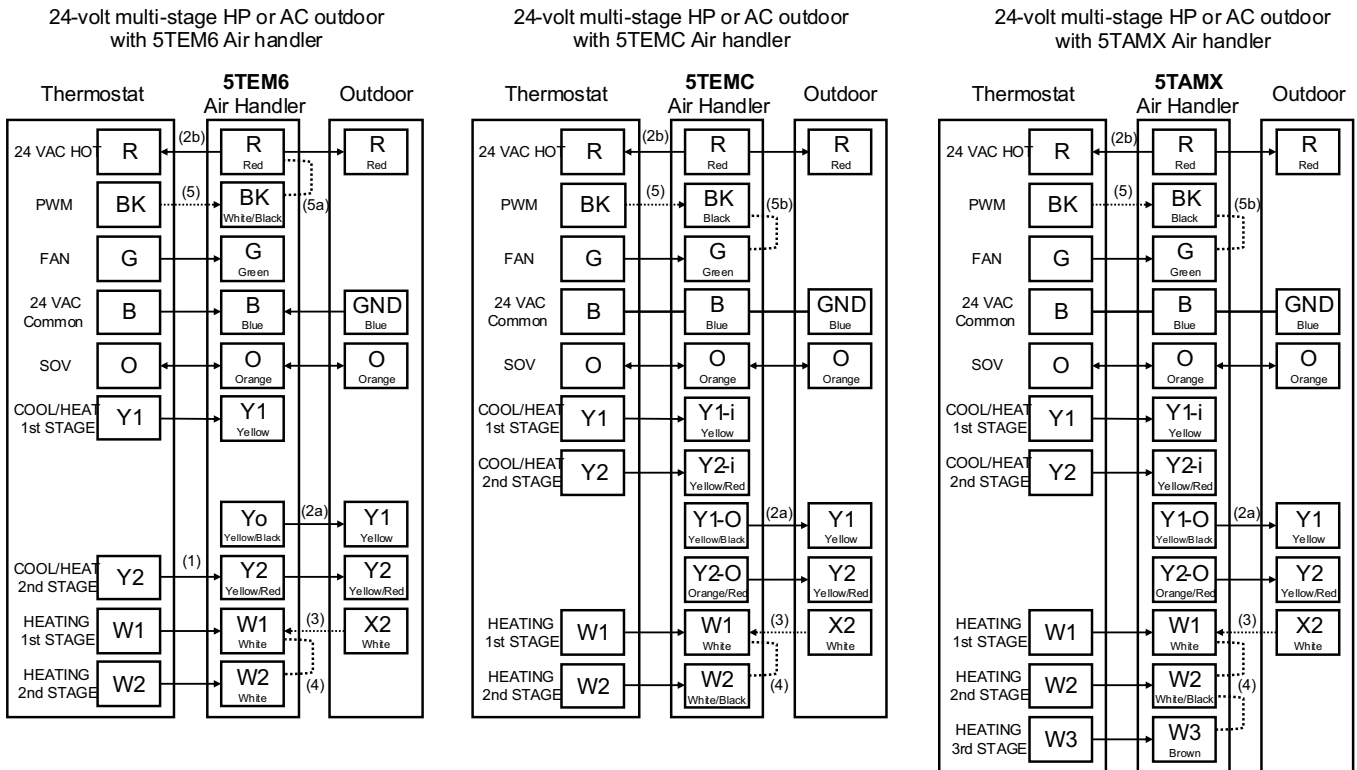

1. Separate Y1 and Y2 at the air handler.
2. Installation options for the condensate switch, float switch, leak detector, etc.:
  - a. Break Y1 to the outdoor so the outdoor shuts down but the indoor blower continues to run.
  - b. Break R to the thermostat so the entire system shuts down.
3. Do not wire X2 with select Trane thermostats, defrost is communicated to the thermostat via the O signal.
4. Do not jump W terminals together with select Trane thermostats, high stage heat is automatically called during defrost.
5. For BK functionality with select Trane thermostats connect BK and either:
  - a. Separate BK from R at the fan control board. Cut and cap both ends of the red/white wire.
  - b. Separate BK from G at the air handler harness.

**Notes:**

- BK dehumidification reduces indoor airflow when active.
- HP models require R and O at the outdoor. AC models do not require O at the outdoor.
- Use wire nuts for all pigtail connections and cap all unused wires.

## Refrigerant Detection System Guidelines

- The approved ID/OD combination will provide sufficient safe ventilation in case of a leak.
- See Indoor Unit Installer's Guide for correct specifications on indoor unit install.
- All systems require Refrigerant Detection Systems.
- RDS (Refrigerant Detection System) included in an A2L system.



# Electrical – High Voltage

## High Voltage Power Supply

**⚠ WARNING**

**Live Electrical Components!**  
 Failure to follow all electrical safety precautions when exposed to live electrical components could result in death or serious injury.  
 When it is necessary to work with live electrical components, have a qualified licensed electrician or other individual who has been properly trained in handling live electrical components perform these tasks.

The high voltage power supply must agree with the equipment nameplate.

Power wiring must comply with national, state, and local codes.

Follow instructions on unit wiring diagram located on the inside of the control box cover and in the Service Facts document included with the unit.

Figure 28. Nameplate location

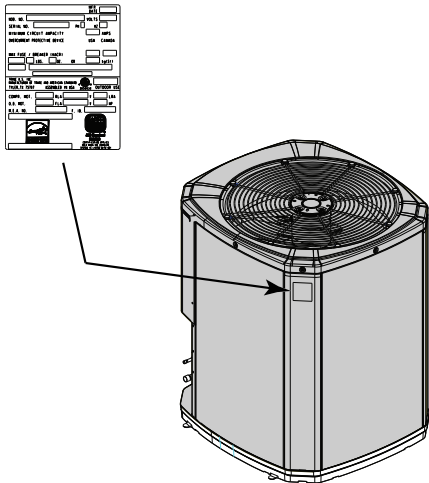

## High Voltage Disconnect Switch

Install a separate disconnect switch at the outdoor unit.

For high voltage connections, flexible electrical conduit is recommended whenever vibration transmission may create a noise problem within the structure.

Figure 29. High voltage disconnect switch

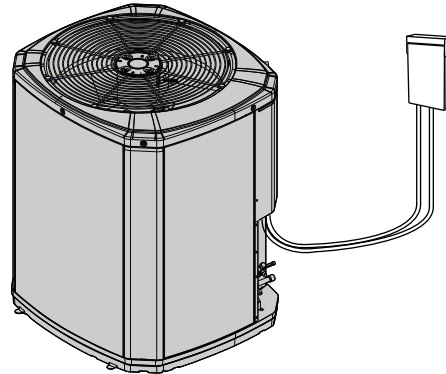

## High Voltage Ground

Ground the outdoor unit per national, state, and local code requirements.

Figure 30. Ground the outdoor unit

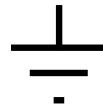

**⚠ WARNING**

**Safety Hazard!**  
 Failure to follow instructions below could result in death or serious injury, and property damage.  
 Confirm the cabling is protected from wear and tear, corrosion, excessive pressure, vibration, sharp edges, and any other adverse environmental effects.

# Integrated Variable Speed Control Board LED Indicators

Figure 31. LED indicators – A1000AA models

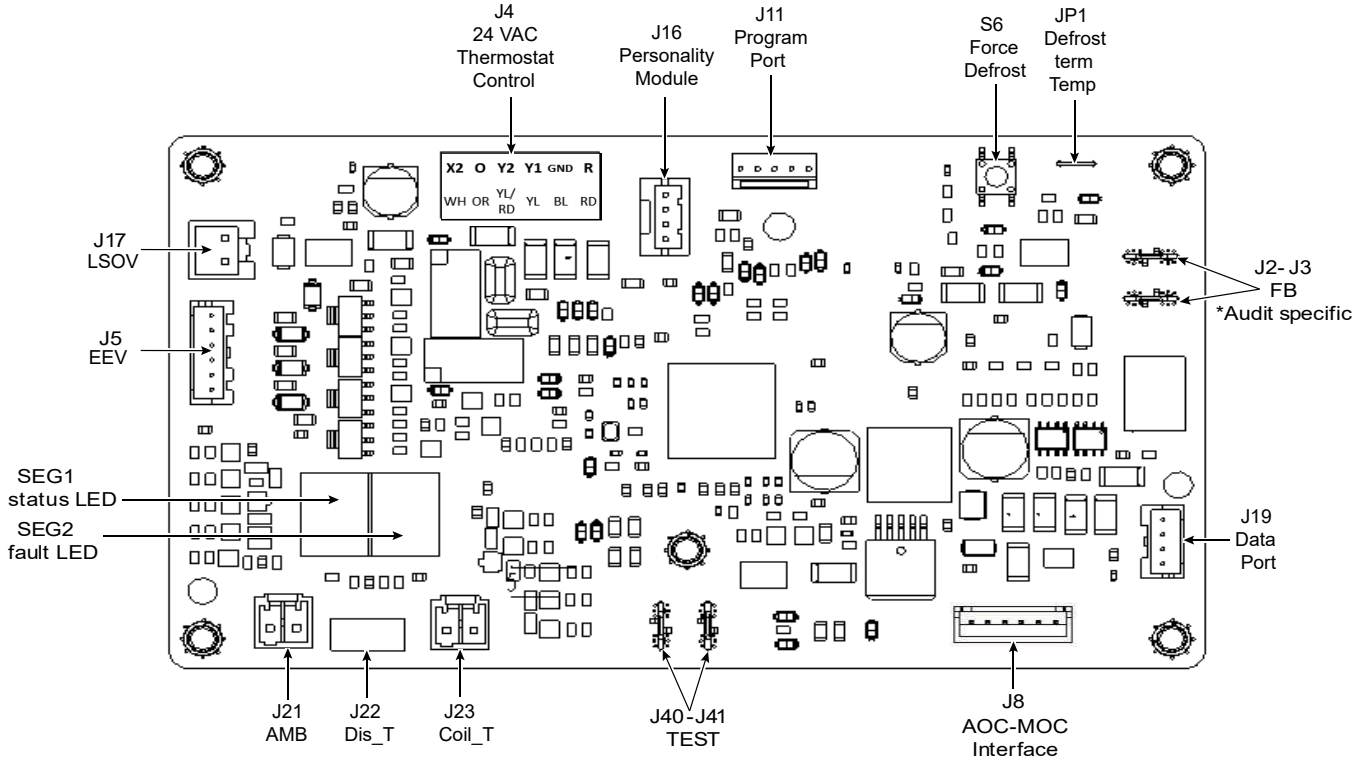

**Notes:**

- *Audit specific.*
- *Multi-speed units display the status and faults via two 7-segment LED displays on the drive AOC.*
- *If multiple faults are present, the 7-segment LED displays will cycle through the faults.*
- *The digital display also offers a diagnostics mode to cycle through historical faults.*

Table 17. Multi-speed status/fault list – A1000AA models

Value	1 <sup>st</sup> Digit - Status	2 <sup>nd</sup> Digit - Faults
0	Standby	No Fault
1	Starting	MOC Fault
2	Low Speed	MOC Communication Fault
3	High Speed	Compressor Internal Protection (IOL/OLP)
4	Boost Speed	Compressor Overcurrent Protection
5	Limp Mode	Outdoor Fan Overcurrent Protection
6	Preheating	High Preheat IPM Temperature Protection
7	Defrosting	High Coil Temperature Protection
8	De-rate	High Discharge Temperature Protection
9	Oil-Return	High MOC Compressor IPM Temperature
A	—	Outdoor Ambient Temperature Sensor Fault

## Integrated Variable Speed Control Board LED Indicators

**Table 17. Multi-speed status/fault list – A1000AA models (continued)**

Value	1 <sup>st</sup> Digit - Status	2 <sup>nd</sup> Digit - Faults
b	—	AOC Jumper Pin Engaged
C	—	Coil Temperature Sensor Fault
d	—	Discharge Temperature Sensor Fault
E	Software Error	High MOC PFC Temperature Protection
F	Fault	High MOC Fan IPM Temperature Protection
H	Hard lock	—
P	—	Pressure Protection (High or Low)

**Figure 32. LED indicators – A1000BA models**

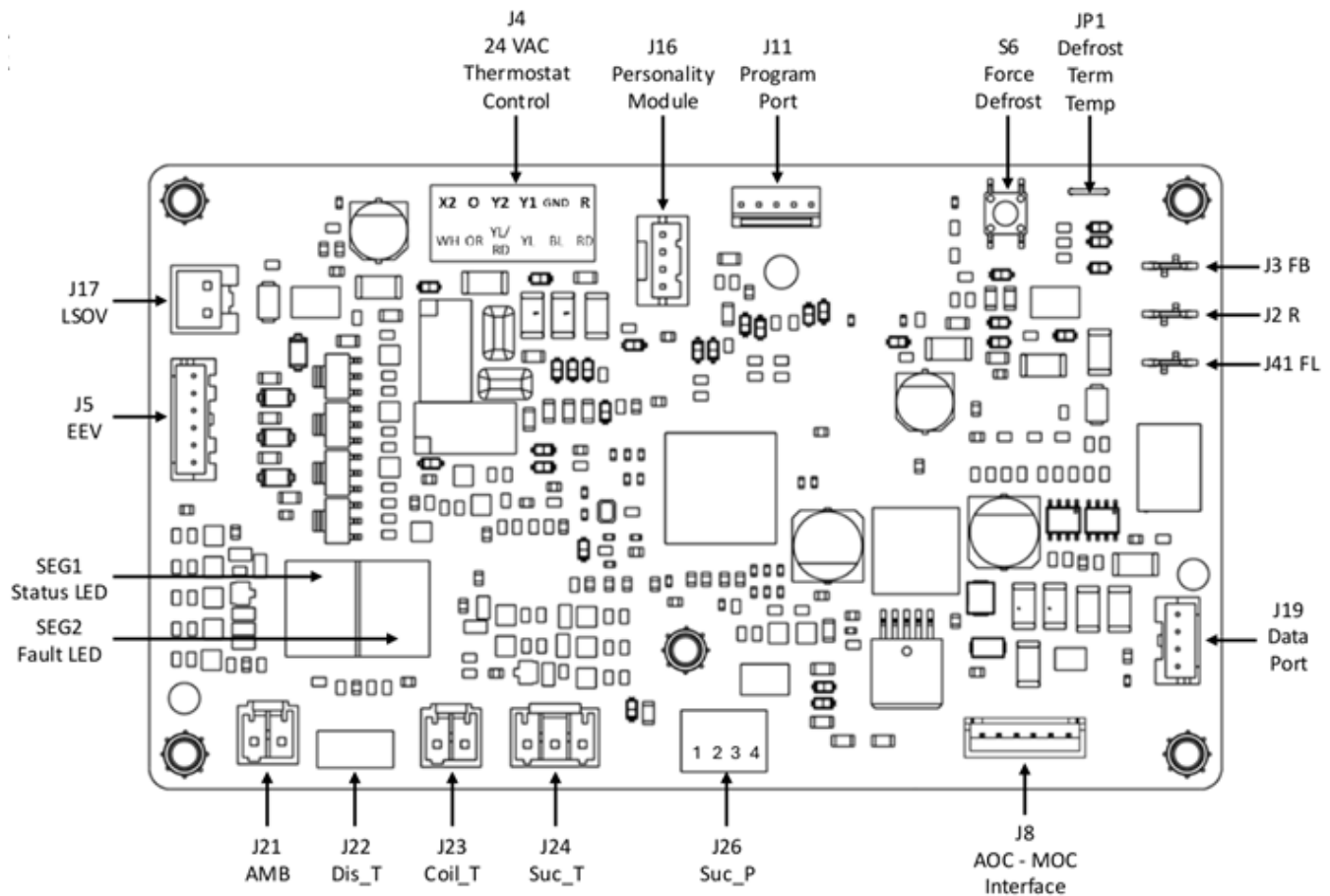

**Notes:**

- Multi-speed units display the status and faults via two 7-segment LED displays on the drive AOC.
- If multiple faults are present, the 7-segment LED displays will cycle through the faults.
- The digital display also offers a diagnostics mode to cycle through historical faults.



## Integrated Variable Speed Control Board LED Indicators

**Table 18. Multi-speed status/fault list – A1000BA models**

Mode	Code/Display	Status	Fault
Run	00	Standby	—
	Y.1	Starting Low	—
	Y.2	Starting High	—
	Y1	Running Low	—
	Y2	Running High	—
	Y2.	Running Boost	—
	50	Limp Mode	—
	60	Preheating	—
	70	Defrosting	—
	J1	AOC FL Jumper Pin Engaged	—
	J2.	AOC FB Jumper Pin Engaged	—
Boot	bt	Boot	—
	E0	Personality Module (PM) Error	PM Invalid or UID Storage Failed
	E1	Configuration Error	Communication Fault, Config Mismatch
	E2	AOC Application Error	AOC Software/Config Parameter Mismatch

## Integrated Variable Speed Control Board LED Indicators

**Table 18. Multi-speed status/fault list – A1000BA models (continued)**

Mode	Code/ Display	Status	Fault
Fault	F0	AOC-MOC Communication Fault	Communication Fault After Boot
	F1	Compressor Start Up Fault	Compressor Start Up fault
	F2	Compressor Over Current	Compressor Over Current
	F3	Compressor Control Fault	Compressor Lost Synchronism Fault
			Compressor Lost Phase
			COMP I-Phase Peak
	F4	Fan Control Fault	OD Fan IPM Overcurrent
			OD Fan Rotation Fault
			OD Fan Lost Phase
			OD Fan Over Current
			OD Fan Start Up Fault
	F5	AC Over Current Fault	Software AC Over Current
			Hardware AC Over Current
			PFC IGBT Over Current
			VDC Hardware Over Voltage
	F6	MOC High Temperature Fault	IPM Over Temperature
			Fan IPM Over Temperature
PFC Over Temperature			
F7	AC Input Voltage Fault	AC Input Voltage Low	
F8	DC Output Voltage Fault	DC Voltage Low	
		DC Voltage High / AC Input Voltage High	
F9	MOC Internal Fault	—	
FA	Ambient Temperature Sensor Fault	AOC OD Ambient Temperature Sensor Fault	
FC	Coil Temperature Sensor Fault	AOC Coil Temperature Sensor Fault	
Fd	Discharge Temperature Sensor Fault	AOC Discharge Temperature Sensor Fault	
Fr	24 Vac Control R-Signal Fault	AOC No 24 Vac Control R-Signal on Heat Pump	
de-rate	dC	De-rate: Compressor Over Current	AOC SW Compressor Overcurrent
	dF	De-rate: Outdoor Fan Over Current	AOC SW Fan Overcurrent (or MOC SW) De-rate
	d5	De-rate: MOC AC Input Over Current	AOC SW MOC AC Input Overcurrent De-rate
	d6	De-rate: High MOC IPM Temperature	AOC SW High MOC IPM Temperature De-rate
	d7	De-rate: High MOC PFC Temperature	AOC SW High MOC PFC Temperature De-rate
	d8	De-rate: High Coil Temperature	AOC SW High Coil Temperature De-rate
	dd	De-rate: High Discharge Temperature	AOC SW High Discharge Temperature De-rate



## Integrated Variable Speed Control Board LED Indicators

**Table 18. Multi-speed status/fault list – A1000BA models (continued)**

Mode	Code/ Display	Status	Fault
Lockout	LC	Lockout: Compressor Over Current	AOC SW Compressor Overcurrent Lockout
	LF	Lockout: Outdoor Fan Over Current	AOC SW Fan Overcurrent Lockout
	L5	Lockout: MOC AC Input Over Current	AOC SW MOC AC Input Overcurrent Lockout
	L6	Lockout: High MOC IPM Temperature	AOC SW High MOC IPM Temperature Lockout
	L7	Lockout: High MOC PFC Temperature	AOC SW High MOC PFC Temperature Lockout
	L8	Lockout: High Coil Temperature	AOC SW High Coil Temperature Lockout
	Ld	Lockout: High Discharge Temperature	AOC SW High Discharge Temperature Lockout
	LL	Lockout: LPCO Low Pressure	AOC Low Suction Pressure Lockout
	LH	Lockout: HPCO / DTC	MOC HPS Circuit Open Lockout
Hard-lock	HC	HardLock: Compressor Over Current	AOC SW Compressor Overcurrent Hard-Lock
	HF	HardLock: Outdoor Fan Over Current	AOC SW Fan Overcurrent Hard-Lock
	H5	HardLock: MOC AC Input Over Current	AOC SW MOC AC Input Overcurrent Hard-Lock
	H6	HardLock: High MOC IPM Temperature	AOC SW High MOC IPM Temperature Hard-Lock
	H7	HardLock: High MOC PFC Temperature	AOC SW High MOC PFC Temperature Hard-Lock
	H8	HardLock: High Coil Temperature	AOC SW High Coil Temperature Hard-Lock
	Hd	HardLock: High Discharge Temperature	AOC SW High Discharge Temperature Hard-Lock
	HL	HardLock: LPCO Low Pressure	AOC Low Suction Pressure Soft-Lock
	HH	HardLock: HPCO / DTC	MOC HPS Circuit Open Hard-Lock



## Start-Up

1. Confirm you have completed the following sections  
"Refrigerant Line Brazing," p. 15 through "Electrical – High Voltage," p. 23.
2. Turn ON disconnect(s) to apply power to the indoor and outdoor units.
3. Wait three hours before starting the unit if the outdoor ambient temperature is below 85° F.
4. Start the unit in cooling mode, if conditions allow.
5. Allow the unit to stabilize at full speed for 20 minute prior to adjust refrigerant charge.

**Figure 33. Apply power**

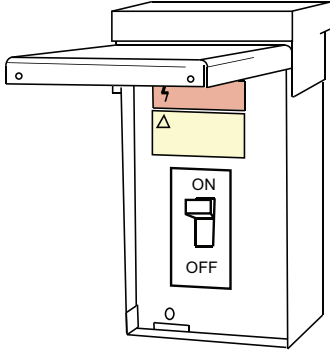



# System Charge Adjustment

## Temperature Measurements

Check the outdoor temperatures.

Subcooling in cooling mode is the only recommended method of charging between 55 ° F and 115° F ambient outdoor temperature.

**Figure 34. Subcooling in cooling mode**

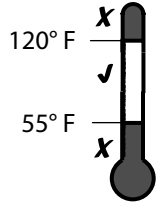

Confirm charge afterward by verifying subcooling.

For best results the indoor temperature should be kept between 70° F to 80° F.

**Figure 35. Indoor temperature**

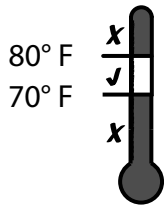

## Subcooling Charging Corrections

Determine the final subcooling value using total Line Length and Lift measured in “Required Refrigerant Line Length” and the “Subcooling Charging Corrections Charts”.

Total Line Length (ft) \_\_\_\_\_

Total Vertical Charge (lift) \_\_\_\_\_

(Values from — Required Refrigerant Line Length)

Design Subcooling Value \_\_\_\_\_

(from nameplate or Service Facts)

**Final Subcooling Value** \_\_\_\_\_

**Note:** Outdoor Temperature must be between 55°F and 115°F with Indoor Temperature kept between 70°F and 80°F. If starting up incolder conditions, will need to return when the conditions are correct to validate refrigerant charge.



# Charging the Unit

## Proper Gauge Pressure

Using the Standard R-454B Subcool Charging Chart, adjust refrigerant level to attain proper gauge pressure.

**Note:** Use bubble point, per the included chart, for calculating subcooling.

Add refrigerant if the Liquid Gauge Pressure is lower than the chart value.

1. Connect gauges to refrigerant bottle and unit as illustrated.
2. Purge all hoses.
3. Place refrigerant bottle on a scale and then open bottle.
4. Stop adding refrigerant when liquid line temperature and Liquid Gauge Pressure match the charging chart.

**Figure 36. Adjust refrigerant level**

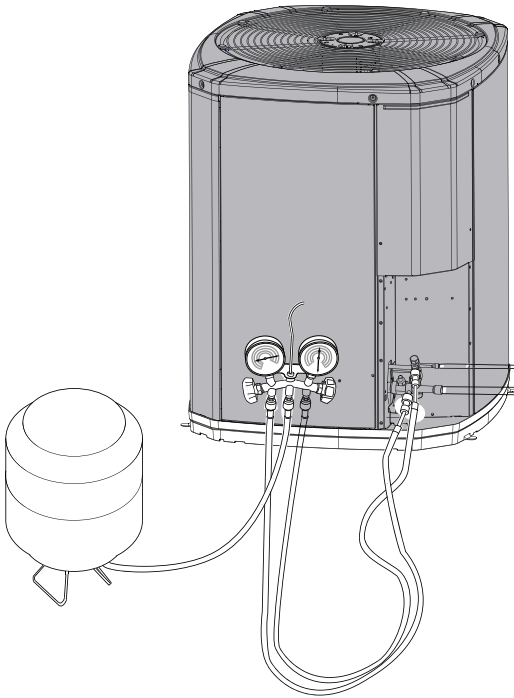

**Notes:**

- Recover refrigerant if the Liquid Gauge Pressure is higher than the chart value
- Confirm that contamination of different refrigerants does not occur when using charging equipment.
- Cylinders shall be kept in an appropriate position according to the instructions. Confirm that the refrigerating system is earthed prior to charging the system with refrigerant.

## Stabilize the System

1. Wait 20 minutes for the system condition to stabilize between adjustments.

**Figure 37. Wait 20 minutes**



When the Liquid Line Temperature and Gauge Pressure approximately match the chart, the system is properly charged.

2. Remove gauges.
3. Replace service port caps to prevent leaks. Tighten finger tight plus an additional 1/6 turn.

## System Information

Record system pressures and temperatures after charging is complete.

- Outdoor model number = \_\_\_\_\_
- Measured Outdoor Ambient = \_\_\_\_\_ °F
- Measured Indoor Ambient = \_\_\_\_\_ °F
- Measured Liquid Line Temp = \_\_\_\_\_ °F
- Measured Suction Line Temp = \_\_\_\_\_ °F
- Indoor Wet Bulb = \_\_\_\_\_ °F
- Liquid Gauge Pressure = \_\_\_\_\_ PSIG
- Suction Gauge Pressure = \_\_\_\_\_ PSIG

## Total System Charge

Complete the “Total System Charge” chart rating label below and label located on the outside of the unit with a permanent marker.

- Charge added at Factory = \_\_\_\_\_ lb/oz
- Charge added at install = \_\_\_\_\_ lb/oz
- Total System Charge (a + b) = \_\_\_\_\_ lb/oz



# Charging Below 55° F Outdoor Temperature in Heating Mode

## Charging below 55° F outdoor temperature in heating mode

The Subcooling Charging method in cooling is not recommended below 55° F outdoor temperature.

The only recommended method of charging at outdoor temperatures below 55° F is weighing in the charge in heating mode.

## Determine Additional Charge

**Note:** The nameplate charge value represents the amount of refrigerant shipped in the outdoor unit and is compatible with 10 feet of AHRI rated refrigerant lines and the smallest AHRI rated coil.

Weigh-In Method can be used for the initial installation, or anytime a system charge is being replaced. Weigh-In Method can also be used when power is not available to the equipment site or operating conditions (indoor/outdoor temperatures) are not in range to verify with the subcooling charging method.

Using the method below, find the charge associated with the additional length of tubing above 10 ft. and record it below.

**Table 19. Calculating charge using the weigh-in method**

Step	Directions	Record Calculations
1	Measure in feet the distance between the outdoor unit and the indoor unit. (Include the entire length of the line from the service valve to the IDU.) Subtract 10 ft. from this entire length and record on line 1.	Total Line length (ft.) – 10 ft _____
2	Enter the charge multiplier (0.47 oz./ft. for 3/8-inch and 0.30 oz./ft. for 5/16-inch).	Charge multiplier = for 3/8-inch, use .47 oz. per foot and for 5/16-inch, use .30 oz. per foot
3	Multiply the total length of refrigerant tubing (Line 1) times the value on Step 2. Record the result on Line 3 of the Worksheet.	Step 1 x Step 2 = _____
4	This is the amount of refrigerant to weigh-in prior to opening the service valves.	Refrigerant (oz) = _____

## Stabilize the System

Stabilize the system by operating for a minimum of 20 minutes.

**Figure 38. Wait 20 minutes**



At startup, or whenever charge is removed or added, the system must be operated for a minimum of 20 minutes to stabilize before accurate measurements can be made.

## Complete the Total System Charge Chart

Complete the “Total System Charge,” p. 31 chart rating label below and label located on the outside of the unit with a permanent marker.

**Note:** Complete the “Total System Charge,” p. 31 chart when final charging is complete.

### Total System Charge

Charge added at Factory = \_\_\_\_\_ lb/oz

Charge added at install = \_\_\_\_\_ lb/oz

Total System Charge (a + b) = \_\_\_\_\_ lb/oz

## Return to Site for Adjustment

**Important:** Return in the spring or summer to accurately charge the system in the “Charging Mode - Cooling” with outdoor ambient above 55° F.



# Defrost Control (Heat Pump only)

## Demand Defrost

The demand defrost control measures heat pump outdoor ambient temperature with a sensor located outside the outdoor coil. A second sensor located on the outdoor coil is used to measure the coil temperature. The difference between the ambient and the colder coil temperature is the difference or Delta-T measurement. This Delta-T measurement is representative of the operating state and relative capacity of the heat pump system. By measuring the change in Delta-T, we can determine the need for defrost. The coil sensor also serves to sense outdoor coil temperature for termination of the defrost cycle.

## Fault Identification

A fault condition is indicated by the LED display on the control board.

## Defrost Enabled

Demand Defrost is enabled with the following inputs to the Integrated Control:

- Outdoor ambient temperature sensor (ODS-B) reporting an outdoor temperature at or below 50° F.
- Heating demand from the thermostat for a specific time period.

## Defrost Initiation

The calculated temperature difference between the outdoor temperature sensor and the coil temperature sensor is called Delta T. Defrost can occur once the current Delta T exceeds the Delta T initiate value. This adaptive logic assures a complete defrost for a range of outdoor temperatures.

## Forced Defrost

- System must be running with demand from the thermostat.
- Forced defrost can be initiated in heat mode only.
- Press and hold the forced defrost button on the control board for over 5 seconds.
- When forced defrost begins the LED display will show a 7 as the first digit.

**Note:** The defrost termination temperature can be increased by clipping the defrost termination jumper pin.

### ⚠ WARNING

#### Safety Hazard!

Failure to follow instructions below could result in death or serious injury and equipment or property damage.

- Do not use any items other than those approved by the manufacturer for defrosting or cleaning process.
- Store the appliance in a room without continuously operating ignition sources (for example: open flames, an operating gas appliance, or an operating electric heater).
- Do not pierce or burn.
- Be cautious that refrigerants may be odorless.

Figure 39. Defrost termination profiles

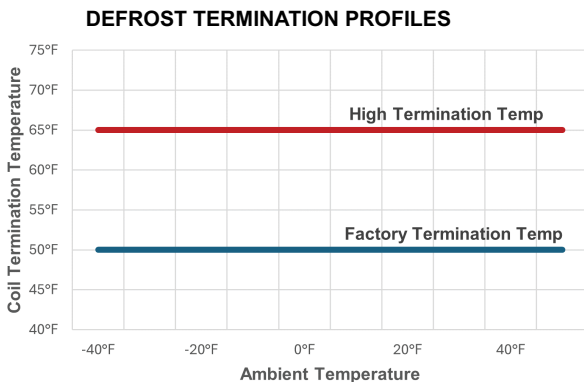







## Checkout Procedures

The final phase of the installation is the system Checkout Procedures. The following list represents the most common items covered in a Checkout Procedure. Confirm all requirements in this document have been met.

- All wiring connections are tight and properly secured.
- Voltage and running current are within limits.
- All refrigerant lines (internal and external to equipment) are isolated, secure, and not in direct contact with each other or structure.
- All braze connections have been checked for leaks. A vacuum of 350 microns provides confirmation that the refrigeration system is leak free and dry. Additional refrigerant weight is recorded on a label by the unit nameplate.
- Final unit inspection to confirm factory tubing has not shifted during shipment. Adjust tubing if necessary so tubes do not rub against each other or any component when unit runs.
- Ductwork is sealed and insulated.
- All drain lines are clear with joints properly sealed. Pour water into drain pan to confirm proper drainage. Provide enough water to ensure drain trap is primed.
- Supply registers and return grilles are open, unobstructed, and air filter is installed.
- Indoor blower and outdoor fan are operating smoothly and without obstruction.
- Indoor airflow should be configured per indoor Installer's Guide.
- Verify blower and fan set screws are tight.
- Cover panels are in place and properly tightened.
- System functions safely and properly in all modes.
- Owner has been instructed on use of system and given manual.
- Confirm Refrigerant Leak Detection system is operational.
- Confirm refrigerant quantity is marked on OD unit.

# Symbols

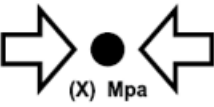
Figure 40. Symbols

	<p>[symbol ISO 7010-W021 (2011-05)]</p>	<p>warning; flammable materials</p>
	<p>[symbol ISO 7000-1659 (2004-01)]</p>	<p>service indicator; read technical manual</p>
	<p>A2L symbol</p>	<p>warning; low burning velocity material</p>
	<p>[symbol ISO 7000-1701 (2004-01)]</p>	<p>pressure</p>
	<p>[symbol IEC 60417-6040 (2010-08)]</p>	<p>ultraviolet radiation, instructional safeguard</p>
	<p>[symbol ISO 7000-1641 (2004-01)]</p>	<p>operator's manual; operating instructions</p>

	<p>Refrigerant class per ISO 817</p>
---	--------------------------------------



# Notices

## FCC Notice

Contains FCC ID: WAP3025

*This device complies with part 15 of the FCC Rules. Operation is subject to the following two conditions: (1) This device may not cause harmful interference, and (2) this device must accept any interference received, including interference that may cause undesired operation. The antenna(s) used for this transmitter must be installed to provide a separation distance of at least 20 cm from all persons and must not be collocated or operating in conjunction with any other antenna or transmitter. This equipment has been tested and found to comply with the limits for Class B Digital Device, pursuant to Part 15 of the FCC Rules. These limits are designed to provide reasonable protection against harmful interference in a residential installation. This equipment generates and can radiate radio frequency energy and, if not installed and used in accordance with the instructions, may cause harmful interference to radio communications. However, there is no guarantee that interference will not occur in a particular installation. If this equipment does cause harmful interference to radio or television reception, which can be determined by turning the equipment off and on, the user is encouraged to try to correct the interference by one or more of the following measures.*

- *Reorient or relocate the receiving antenna*
- *Increase the separation between the equipment and receiver*
- *Connect the equipment into an outlet on a circuit different from that to which the receiver is connected*
- *Consult the dealer or an experienced radio/TV technician for help*

*Any changes or modifications not expressly approved by the party responsible for compliance could void the user's authority to operate the equipment.*

## IC Notice

Contains IC ID: 7922A-3025

*This device complies with Industry Canada license exempt RSS standard(s). Operation is subject to the following two conditions: (1) this device may not cause interference, and (2) this device must accept any interference, including interference that may cause undesired operation of the device.*

*Le présent appareil est conforme aux CNR d'Industrie Canada applicables aux appareils radio exempts de licence. L'exploitation est autorisée aux deux conditions suivantes: (1) l'appareil de doit pas produire de brouillage, et (2) l'utilisateur de l'appareil doit accepter tout brouillage radioélectrique subi, même si le brouillage est susceptible d'en compromettre le fonctionnement.*









Trane - by Trane Technologies (NYSE: TT), a global innovator - creates comfortable, energy efficient indoor environments for commercial and residential applications. For more information, please visit [trane.com](http://trane.com) or [tranetechnologies.com](http://tranetechnologies.com).

Trane has a policy of continuous data improvement and it reserves the right to change design and specifications without notice. We are committed to using environmentally conscious print practices.

ODR-SVN002E-EN 18 Apr 2026  
Supersedes ODR-SVN002D-EN (April 2026)

©2026 Trane