

# Installation Instructions

## Enthalpy Sensor Control



**Model Number:**  
BAYENTH001

**Used With:**  
BAYECON054, 055, and 073  
BAYECON086A, 088A  
BAYECON101, 102  
BAYECON105, 106

### **⚠ SAFETY WARNING**

Only qualified personnel should install and service the equipment. The installation, starting up, and servicing of heating, ventilating, and air-conditioning equipment can be hazardous and requires specific knowledge and training. Improperly installed, adjusted or altered equipment by an unqualified person could result in death or serious injury. When working on the equipment, observe all precautions in the literature and on the tags, stickers, and labels that are attached to the equipment.

November 2024

**ACC-SVN85C-EN**

# Warnings and Cautions

---

## Overview of Manual

**Note:** *One copy of this document ships inside the control panel of each unit and is customer property. It must be retained by the unit's maintenance personnel.*

This booklet describes proper installation, operation, and maintenance procedures for air cooled systems. By carefully reviewing the information within this manual and following the instructions, the risk of improper operation and/or component damage will be minimized.

It is important that periodic maintenance be performed to help assure trouble free operation. A maintenance schedule is provided at the end of this manual. Should equipment failure occur, contact a qualified service organization with qualified, experienced HVAC technicians to properly diagnose and repair this equipment.

## Hazard Identification

Warnings and Cautions appear at appropriate sections throughout this manual. Read these carefully.

### **WARNING**

Indicates a potentially hazardous situation which, if not avoided, could result in death or serious injury.

### **CAUTION**

Indicates a potentially hazardous situation which, if not avoided, may result in minor or moderate injury. It may also be used to alert against unsafe practices.

### **CAUTION**

Indicates a situation that may result in equipment or property-damage-only accidents.

## Model Number Description

All products are identified by a multiple-character model number that precisely identifies a particular type of unit. Its use will enable the owner/operator, installing contractors, and service engineers to

define the operation, specific components, and other options for any specific unit.

When ordering replacement parts or requesting service, be sure to refer to the specific model number and serial number printed on the unit nameplate.

## General Information

The solid state enthalpy sensor is used with a solid state economizer actuator motor.

# Installation

## Installation For BAYECON054,055 Downflow Discharge Economizer

### Single Enthalpy Sensor (Outdoor Air Only)

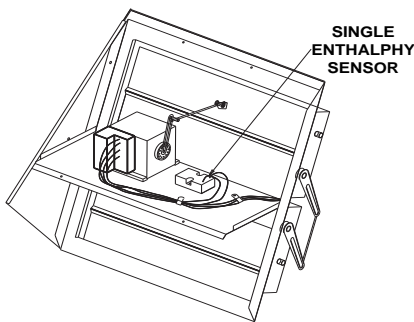

Figure 1.

- Units with economizers already installed: When installing the enthalpy sensor after the economizer has been installed remove the economizer/filter access panel located on the return side of the unit.
- Remove the two screws securing the disk type thermostat to the top of the motor deck.
- Next, disconnect the wires 56A and 50A(YL) from the thermostat.
- Using the two screws removed in step 2, mount the Enthalpy sensor in the thermostat's previous location, [Figure 1](#).
- Connect wire 56A to S and 50A(YL) to + terminals on the Enthalpy Sensor.
- On the Control Module (Solid State Economizer Logic Module) attached to the Economizer Motor, remove the red resistor from terminals S<sub>R</sub> and + and discard. See [Figure 3](#).
- Remove the white resistor from between the S<sub>O</sub> terminal and wire 56A. Then install the white resistor across the S<sub>R</sub> and + terminals

- Install the terminal adaptor provided with the sensor on terminal S<sub>O</sub> of the Control Module and connect wire 56A to it.
- Replace the economizer/filter access panel.

### Installation for Differential Enthalpy

#### Sensing (Outside Air & Return Air)

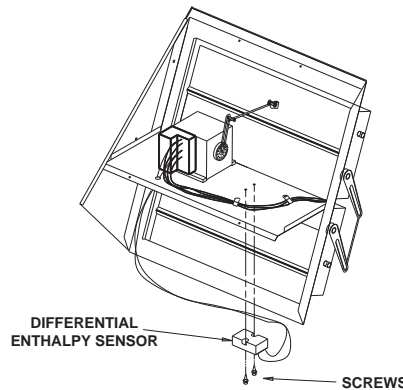

Figure 2.

- Complete the procedures for installing a single enthalpy sensor.
- Mount the second enthalpy sensor on the bottom side of the motor deck, see [Figure 2](#).
- Remove the knockout located below the Economizer Motor and insert a snap bushing.
- Install field supplied wires through the snap bushing from terminals S and + on the return enthalpy sensor to the S<sub>R</sub> and + terminals on the Control Module.
- On the Control Module attached to the Economizer Motor, remove the white resistor from between the S<sub>O</sub> terminal and wire 56A. Then connect the wire from S on the sensor to S<sub>R</sub> on the Control Module and + on the sensor to + on the Control Module.

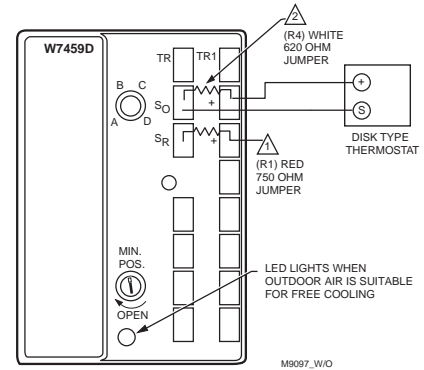

Figure 3. Control module before installation

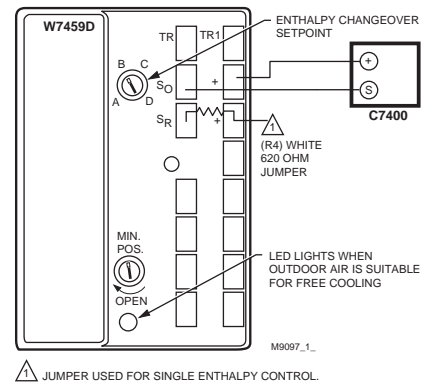

Figure 4. Control module with one enthalpy sensor

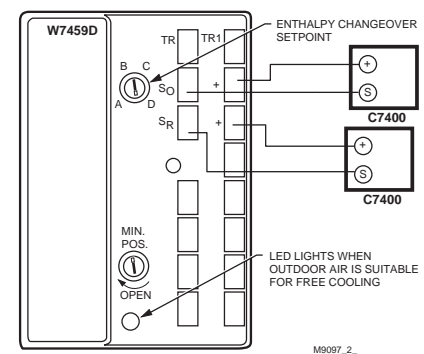

Figure 5. Control module with two enthalpy sensors

## Installation

### Installation for BAYECON073 Horizontal Discharge Economizer:

#### Single Enthalpy Sensor (Outdoor Air Only)

1. **Units with economizers already installed:** When installing the enthalpy sensor after the economizer has been installed remove the economizer rain hood.
2. Remove the two screws securing the disk type thermostat on the damper side of the economizer.
3. Next, disconnect the wires 56A and 50A(YL) from the thermostat.
4. Using the two screws removed in step 2, mount the Enthalpy sensor on the outside face of the economizer. See [Figure 6](#).
5. Connect wire 56A to S and 50A(YL) to + terminal on the Enthalpy sensor.
6. Remove the filter access panel on the return side of the unit reach into the Control Module attached to the Economizer Motor, remove the red resistor from terminals S<sub>R</sub> and + and discard. See [Figure 3](#).
7. Remove the white resistor from between the S<sub>O</sub> terminal and wire 56A. Then install the white resistor across the S<sub>R</sub> and + terminals
8. Install the terminal adaptor provided with the sensor on terminal S<sub>O</sub> of the Control Module and connect wire 56A to it.
9. Reinstall the rain hood and filter access panel.

#### Installation for Differential Enthalpy Sensing

1. Complete the procedures for installing a single enthalpy sensor.
2. Mount the second enthalpy sensor in the return air stream. See [Figure 6](#).

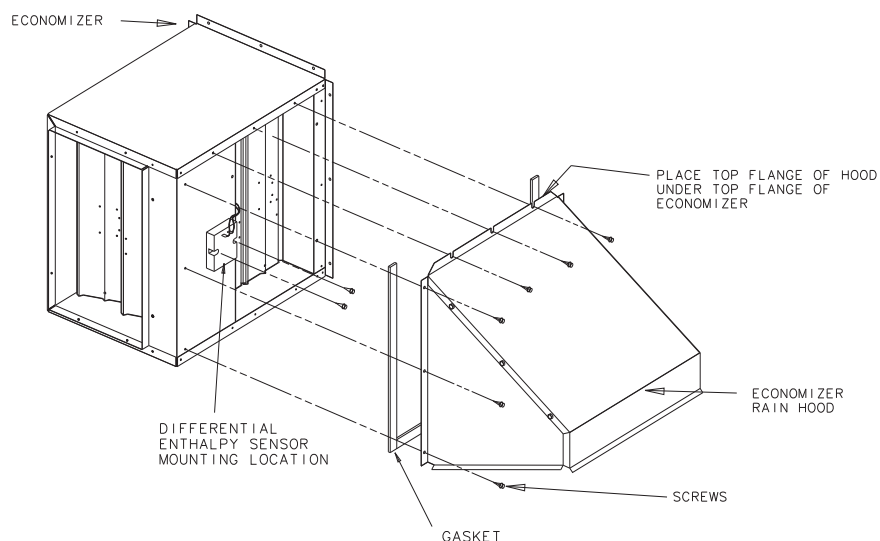

Figure 6.

3. Install field supplied wires through from terminals S and + on the return enthalpy sensor to the S<sub>R</sub> and + terminals on the Control Module.
4. On the Control Module (Solid State Economizer Logic Module) attached to the Economizer Motor, remove the white resistor from between the S<sub>R</sub> terminal and the + terminal. Then connect the wire from S on the sensor to S<sub>R</sub> on the Control Module and + on the sensor to + on the Control Module.
3. Disconnect the wires 182A(YL) and 183A(YL) from the thermostat.
4. Locate bushing supplied with kit and pull wires 182A(YL) and 183A(YL) through bushing. Snap bushing into the hole where the thermostat was removed.
5. Connect wire 182A(YL) to S and 183A(YL) to + terminals on the Enthalpy Sensor.
6. Using the two screws removed in step 2, mount the Enthalpy sensor adjacent to thermostat's previous location, Engagement holes are provided.

### Installation for BAYECON086A, BAYECON088A Downflow Discharge

#### Single Enthalpy Sensor (Outdoor Air Only)

1. **Units with economizers already installed:** When installing the enthalpy sensor after the economizer has been installed remove the economizer/filter access panel located on the front side of the unit. Remove the mist eliminator and retaining angle from the economizer.
2. Remove the two screws securing the disk type thermostat to the rear panel.
3. Disconnect the wires 182A(YL) and 183A(YL) from the thermostat.
4. Locate bushing supplied with kit and pull wires 182A(YL) and 183A(YL) through bushing. Snap bushing into the hole where the thermostat was removed.
5. Connect wire 182A(YL) to S and 183A(YL) to + terminals on the Enthalpy Sensor.
6. Using the two screws removed in step 2, mount the Enthalpy sensor adjacent to thermostat's previous location, Engagement holes are provided.
7. On the Control Module (Solid State Economizer Logic Module) attached to the Economizer Motor, remove the red resistor from terminals S<sub>R</sub> and + and discard. See [Figure 3](#).
8. Remove the white resistor from between the S<sub>O</sub> terminal and wire 182A(YL). Then install the white resistor across the S<sub>R</sub> and + terminals
9. Install the terminal adaptor provided with the sensor on terminal S<sub>O</sub> of the Control Module and connect wire 182A(YL) to it.
10. Replace the economizer/filter access panel and mist eliminator.

## Installation

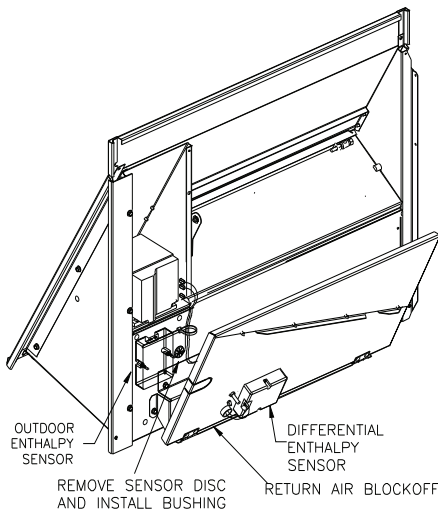

Figure 7. Downflow differential

### Installation for Differential Enthalpy Sensing (Two Sensors)

1. Complete the procedures for installing a single enthalpy sensor.
2. Mount the second enthalpy sensor on the bottom side of the Return Air Bolckoff.
3. Remove the knock-out located near the front side of the Return Air Bolckoff and insert a snap bushing.
4. Install field supplied wires through the snap bushing from terminals S and + on the return enthalpy sensor to the S<sub>R</sub> and + terminals on the Control Module.
5. On the Control Module attached to the Economizer Motor, remove the white resistor from between the S<sub>R</sub> terminal and the + terminal and discard. Then connect the wire from S on the sensor to S<sub>R</sub> on the Control Module and + on the sensor to + on the Control Module.

### Installation for BAYECON086A, BAYECON088A Horizontal Discharge

#### Single Enthalpy Sensor (Outdoor Air Only)

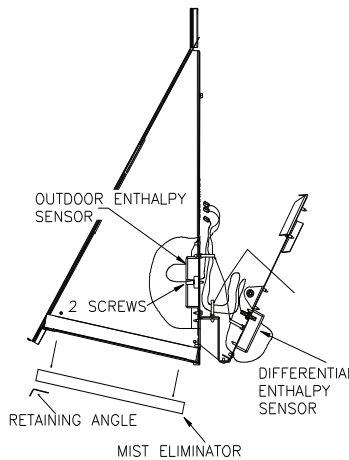

1. **Units with economizers already installed:** When installing the enthalpy sensor after the economizer has been installed remove the economizer/filter access panel located on the front side of the unit. Remove the mist eliminator and retaining angle from the economizer.
2. Remove the two screws securing the disk type thermostat to the rear panel.
3. Disconnect the wires 182A(YL) and 183A(YL) from the thermostat.
4. Locate bushing supplied with kit and pull wires 182A and 183A) through bushing. Snap bushing into the hole where the thermostat was removed.
5. Connect wire 182A to S and 183A to + terminals on the Enthalpy Sensor.
6. Using the two screws removed in step 2, mount the Enthalpy sensor adjacent to thermostat's previous location, engagement holes are provided.
7. On the Control Module (Solid State Economizer Logic Module) attached to the Economizer Motor, remove the red resistor from terminals S<sub>R</sub> and + and discard.
8. Remove the white resistor from between the S<sub>o</sub> terminal and

wire 182A. Then install the white resistor across the S<sub>R</sub> and + terminals

9. Install the terminal adapter provided with the sensor on terminal S<sub>o</sub> of the Control Module and connect wire 182a to it.
10. Replace the economizer/filter access panel and mist eliminator.

### Installation for Differential Enthalpy Sensing (Two Sensors)

1. Complete the procedures for installing a single enthalpy sensor.
2. Mount the second enthalpy sensor on the side of the return air hood
3. Remove the knock-out located near the front side of the Return Air Bolckoff and insert a snap bushing.
4. Install field supplied wires through the snap bushing from terminals S and + on the return enthalpy sensor to the S<sub>R</sub> and + terminals on the Control Module.
5. On the Control Module attached to the Economizer Motor, remove the white resistor from between the S<sub>R</sub> terminal and the + terminal and discard. Then connect the wire from S on the sensor to S<sub>R</sub> on the Control Module and + on the sensor to + on the Control Module.

### Installation for BAYECON101, BAYECON102, BAYECON105, BAYECON106 Down Discharge

#### Single Enthalpy Sensor (Outdoor Air Only)

1. Units with economizers already installed: When installing the enthalpy sensor after the economizer has been installed remove the economizer/filter access panel located on the front side of the unit. Remove the mist eliminator and retaining angle from the economizer.

## Installation

---

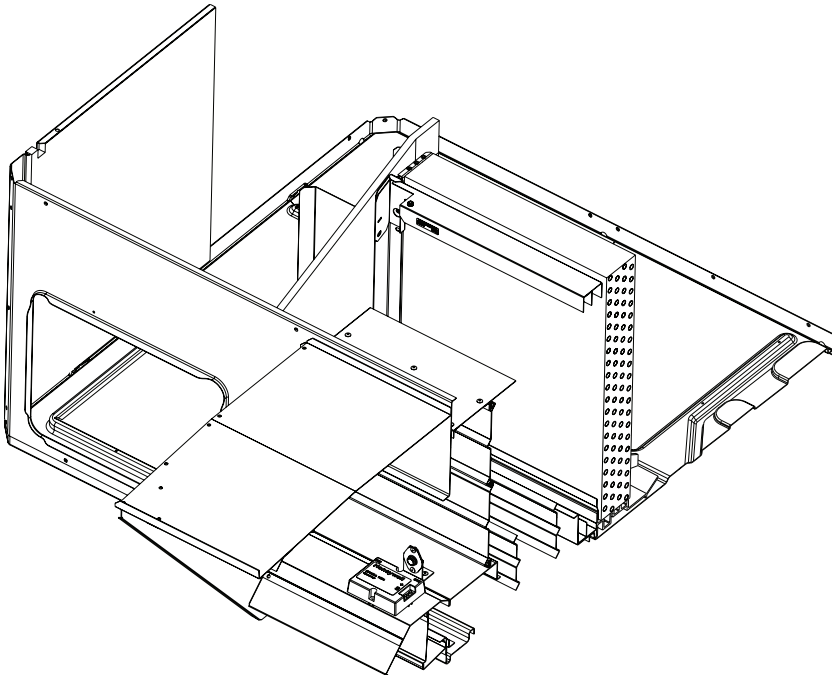

**Figure 8.**

2. Remove the two screws securing the disk type thermostat to the rear panel.
3. Disconnect the YL/BK and YL wires from the thermostat.
4. Retain the screws for later use and discard the remaining items removed in steps 2 & 3 above.
5. Using the two screws removed in step 2, mount the Enthalpy sensor adjacent to thermostat's previous location, Engagement holes are provided.
6. Replace the mist eliminator.
7. Connect the YL/BK wire to S and the YL wire to + terminal on enthalpy sensor.

# Operation

## Controller Dial Setting

Control set point scale is located on the Control Module. Control points A, B, C, D are field selectable, and are used for single enthalpy sensing.

The Solid State Enthalpy Sensor is used with a solid state economizer control and damper actuator to proportion an outdoor air damper in a ventilation system.

**When using a single enthalpy control setpoint A, B, C, or D** combines temperature and humidity conditions resulting in the control curve shown on the psychrometric chart below.

When the enthalpy of the outdoor air is below (left of) the appropriate curve, the outdoor air damper can proportion open on a call for cooling. If the outdoor air enthalpy rises above (right of) the control curve, the outdoor air damper will close to minimum position.

**For differential enthalpy**, you must turn the control set point past D (fully clockwise).

If the outdoor air enthalpy is lower than the return air enthalpy, the outdoor air damper will proportion open on a call for cooling.

If the outdoor air enthalpy is higher than the return air enthalpy, the outdoor air damper will close to minimum position.

If the outdoor air enthalpy and return air enthalpy are equal, the outdoor air damper will proportion open on a call for cooling.

CONTROL CURVE	CONTROL POINT APPROX. F (C) AT 50% RH
A	73 (23)
B	70 (21)
C	67 (19)
D	63 (17)

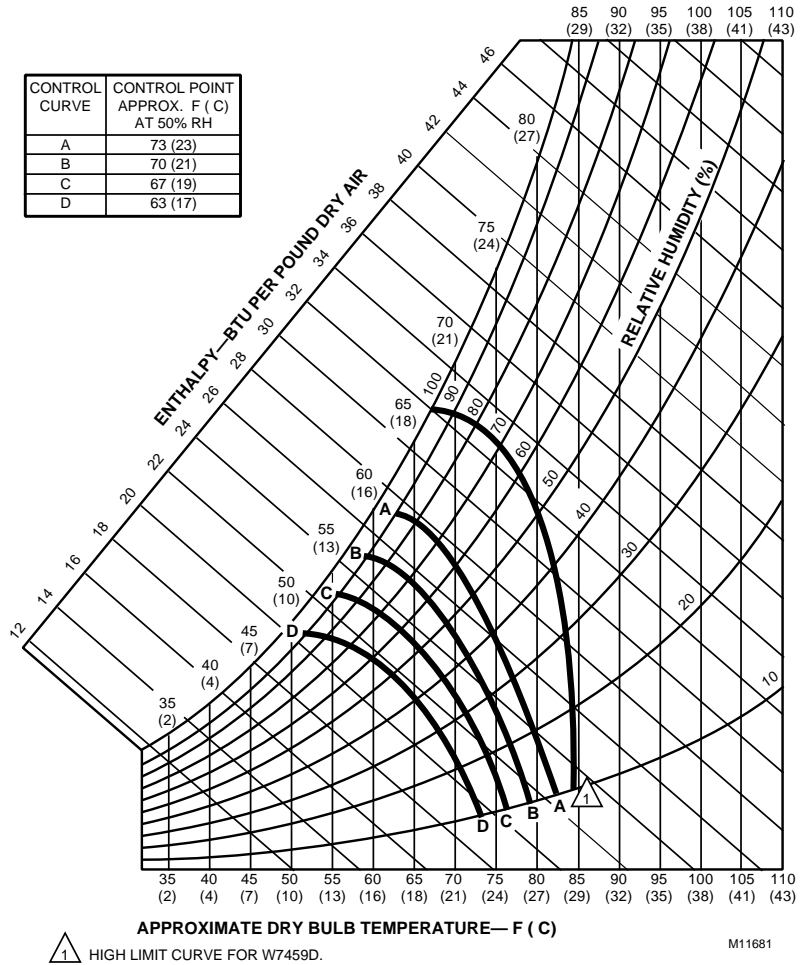
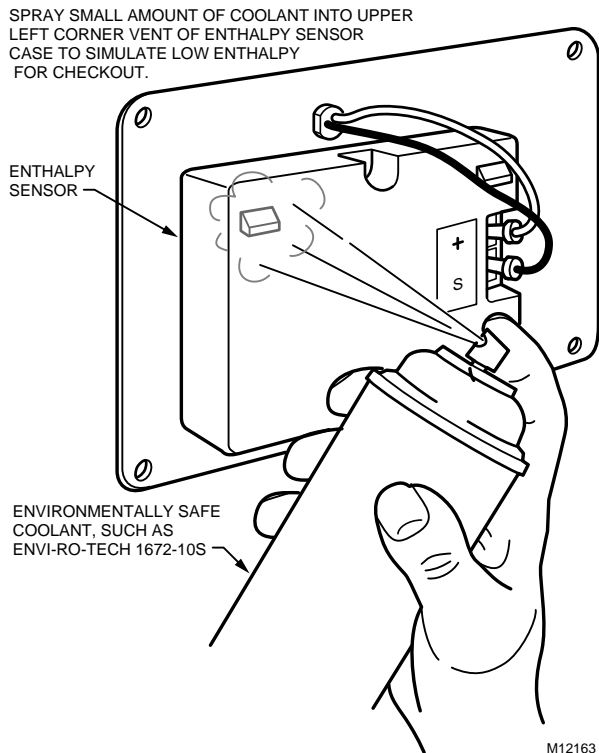

Figure 1.

# Troubleshooting

**Table 1. Checkout and troubleshooting**

Checkout Procedure for Single Sensor	Response
Make sure enthalpy sensor is connected to SO and +. The white resistor must be placed on SR and +.	
Turn enthalpy set point to "A"	"LED" (light -emitting diode) turns on within a minute.
With power connected, spray a small amount of environmentally safe coolant in upper left vent of sensor to simulate low enthalpy conditions. (See <a href="#">Figure 10</a> )	Terminals 2, 3 closed. Terminals 1, 2 open.
Disconnect power at TR and TR1.	Terminals 2, 3 open. Terminals 1, 2 closed.
Checkout procedure for Differential Enthalpy (Second enthalpy sensor connected to terminals "SR" and "+")	Response
Turn enthalpy set point past "D" (full clockwise).	LED turns off.
With power connected, spray a small amount of refrigerant into upper left vent of sensor connected to SO and + to simulate low outdoor air enthalpy. (See <a href="#">Figure 10</a> ).	Terminals 2, 3 closed. Terminals 1, 2 open.
Spray small amount of environmentally safe coolant in upper left vent of return air enthalpy sensor connected to SR and + to simulate low return air enthalpy.	LED turns off. Terminals 2, 3 open. Terminals 1, 2 closed.



**Figure 1.**



# Wiring

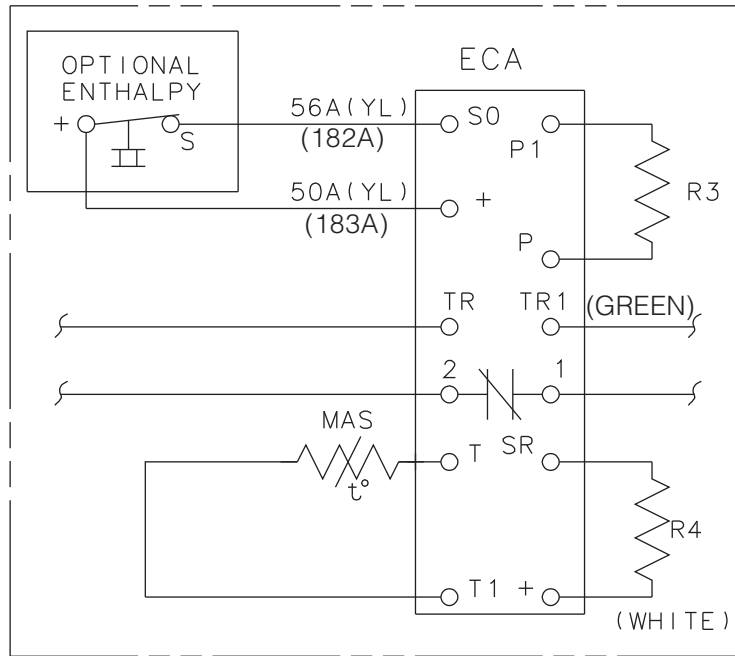

Figure 1. Enthalpy sensor wiring when used with BAYECON054, 055 & 73

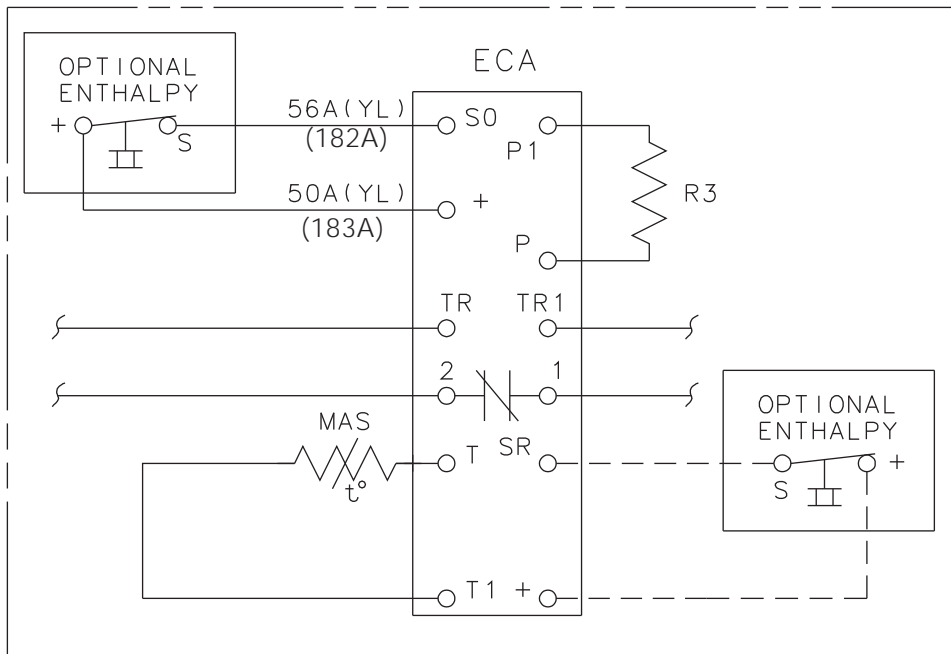

Figure 2. Economizer with optional differential enthalpy sensors

## Wiring

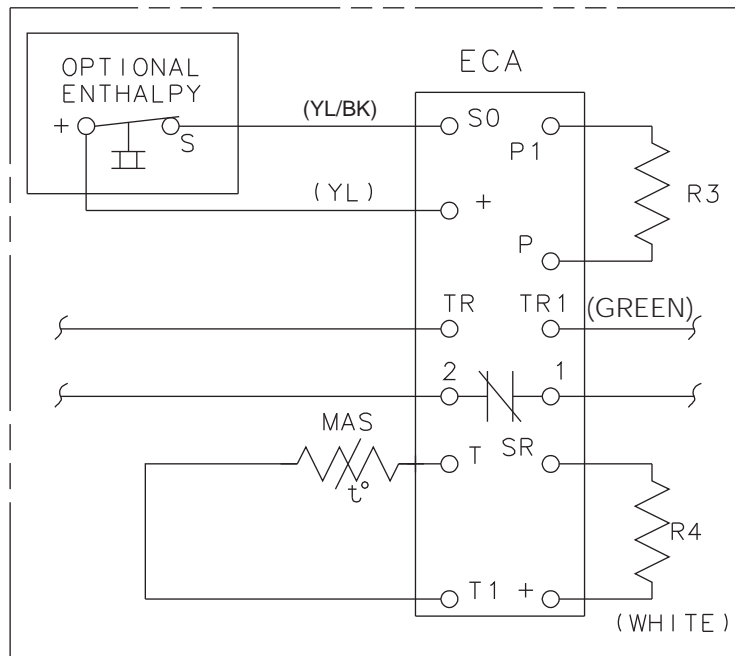

Figure 3. Economizer with optional outdoor enthalpy sensor



Trane and American Standard create comfortable, energy efficient indoor environments for commercial and residential applications. For more information, please visit [trane.com](http://trane.com) or [americanstandardair.com](http://americanstandardair.com).

---

Trane and American Standard have a policy of continuous product and product data improvement and reserve the right to change design and specifications without notice. We are committed to using environmentally conscious print practices.