

Installer's Guide

15 Series System (R-410A) Multi-Zone, Inverter System

ALL phases of this installation must comply with **NATIONAL, STATE AND LOCAL CODES**.

IMPORTANT — This Document is customer property and is to remain with this unit. Please return to service information pack upon completion of work.

These instructions do not cover all variations in systems or provide for every possible contingency to be met in connection with the installation. Should further information be desired or should particular problems arise which are not covered sufficiently for the purchaser's purposes, the matter should be referred to your installing dealer or local distributor.

Multi-Zone	Outdoor Unit
Heat Pump	M4THM15-A

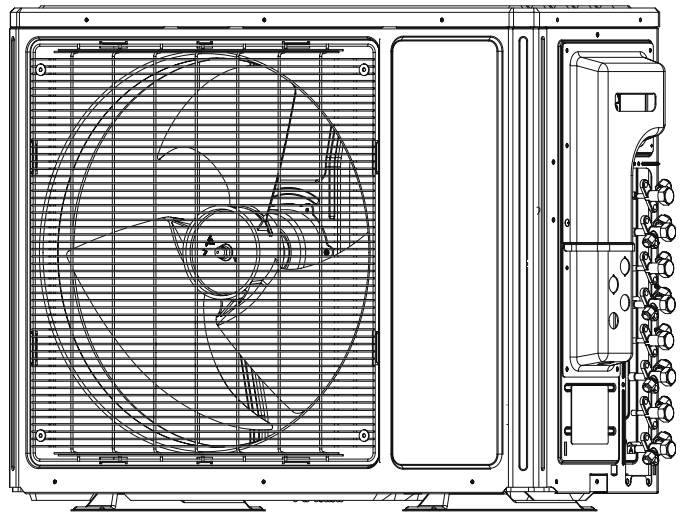



Warnings and Cautions

Warnings are provided to alert others of the potential hazards that could result in severe personal injury or death, while cautions are designed to alert others of the conditions that could result in minor or moderate injury.

Your personal safety and the proper operation of this machine depend upon the strict observance of these precautions.

Attention: Warnings and Cautions appear at appropriate sections throughout this literature. Read these carefully.

 **WARNING:** Indicates a potentially hazardous situation which, if not avoided, could result in death or serious injury.

 **CAUTION:** Indicates a potentially hazardous situation which, if not avoided, could result in minor or moderate injury. It may also be used to alert against unsafe practices.

NOTICE: Indicates a situation that could result in equipment or property damage.

WARNING

This equipment is to be serviced by professionally trained personnel ONLY. Under NO circumstances should an unqualified person service it. This equipment contains refrigerant under PRESSURE and operates at HIGH VOLTAGE. Improperly installed, adjusted or altered equipment by an unqualified person poses safety hazards including FIRE, ELECTROCUTION, or EXPLOSION, which could result in death or serious injury.

WARNING

Electrocution and Fire Hazards with Improperly Installed and Grounded Field Wiring!

Improperly installed and grounded field wiring poses FIRE and ELECTROCUTION hazards. To avoid these hazards, you MUST follow requirements for field wiring installation and grounding as described in the National Electrical Codes (NEC) and your State and/or local electrical codes. All field wiring MUST be performed by qualified personnel. Failure to follow these requirements could result in death or serious injury.

Warnings and Cautions

WARNING

R410-A Refrigerant under Higher Pressure than R-22!

The units described in this manual use R410-A refrigerant which operates at 50 to 70% higher pressures than R-22. Use only R-410A approved service equipment. Refrigerant cylinders are painted with "pink" color to indicate the type of refrigerant and may contain a "dip" tube to allow for charging of liquid refrigerant into the system. For specific handling concerns with R-410A, please contact your local sales office.

Failure to use R-410A approved service equipment could result in standard equipment exploding under R-410A higher pressure which could result in death or serious injury.

NOTICE

Use appropriate oil with R410A systems. Oil type is found at the bottom of Connection Pipe Requirements table (included in the outdoor unit installation manual). R-410A systems utilize POE (Polyolester) or PVE(Polyvinyl Ether) oil. Both oil types absorb moisture readily, yet, lubrication properties vary. Do not leave the sealed system open to atmosphere except during service for a short period of time. If the sealed system is left open longer than four hours, the compressor oil must be changed. These systems utilize strainers placed before and after the expansion device in the outdoor unit, if debris or moisture is suspected, these strainers must be changed. Do not break a vacuum with air. Do not leak check the sealed system with compressed air. Unless instructed by factory service representative, external refrigeration driers are prohibited.

USE ONLY THE FACTORY RECOMMENDED OIL TYPE!

Important!

Environmental Concerns

Scientific research has shown that certain man-made chemicals can affect the earth's naturally occurring stratospheric ozone layer when released to the atmosphere. In particular, several of the identified chemicals that may affect the ozone layer are refrigerants that contain chlorofluorocarbons (CFC's) and those containing hydro-chlorofluorocarbons (HCFC's). Not all refrigerants containing these compounds have the same potential impact to the environment. The Company advocates the responsible handling of all refrigerants, including industry replacements for CFC's such as HCFC's and HFC's.

Responsible Refrigerant Practices



The manufacturer believes that responsible refrigerant practices are important to the environment, our customers, and the air conditioning industry. All technicians who handle refrigerants must be certified. The Federal Clean Air Act (Section 608) sets forth the requirements for handling, reclaiming, recovering and recycling of certain refrigerants and the equipment that is used in these service procedures. In addition, some states or municipalities may have additional requirements that must also be adhered to for responsible management of refrigerants. Know the applicable laws and follow them.

Table of Contents

Safety Precautions	5
Pre-Installation Checklist	6
Product Introduction	7
Combinations for Outdoor and Indoor Units	7
Operating Ranges	9
Preparation for Installation.....	10
Selecting the Installation Location.....	10
Connection Pipe Requirement.....	11
Refrigerant Piping Precautions.....	12
Installing the Outdoor Unit.....	13
Condensate Management of the Outdoor Unit.....	13
Installing the Refrigerant Piping.....	14
Flaring Process and Bending Pipes	14
Insulating the Refrigerant Piping and Connections	15
Refrigerant Piping at the Outdoor Unit	16
Piping Requirements	17
Refrigerant Piping Between the Indoor and Outdoor Units	18
Vacuum and Refrigerant Leakage Detection.....	20
Wiring Precautions	21
Outdoor Wiring Connections	21
Stranded Wiring Connections.....	22
Electrical Connections.....	23
Power Supply Wiring	24
Cable Specifications and Grounding Requirements.....	24
Installation of Controllers	24
Post Installation Checklist	25
Refrigerant System Diagrams	26
Electrical Connections at the Outdoor Unit.....	28
Wiring Diagrams	30
Dimensional Diagrams	33
Troubleshooting.....	35
Error Codes	36
Maintenance.....	38
Parts Replacement.....	38
After-Sales Service.....	38

Safety Precautions

Your personal safety and the proper operation of this equipment depend upon the strict observance of these precautions.

 WARNING	This mark indicates a potentially hazardous situation which, if not avoided, could result in death or serious injury.
 CAUTION	This mark indicates a potentially hazardous situation which, if not avoided, could result in minor or moderate injury. It may also be used to alert against unsafe practices.
NOTICE	This mark indicates a situation which could result in equipment and/or property damage.

 WARNING	
1.	Installation should performed by a qualified HVAC professional. Industry Standard Personal Protective Equipment (PPE) and gear for height related safety should be worn during installation. Improper personal safety precautions and installation may cause death or serious injury.
2.	Install the air conditioner according to the instructions given in this manual. Incomplete installation work may cause water leakage, electrical shock or fire.
3.	Use the supplied or specified installation parts. Use of other parts may cause the unit to come loose, resulting in water leakage, electrical shock or fire.
4.	Install the unit in a location that can support the weight of the unit. An inadequate support structure or incomplete installation may cause injury or property damage in the event the unit falls off of the installation location. Refer to the installation specifications for additional requirements.
5.	Electrical work should be carried out in accordance with the installation manual and local, state and National Electric Code (NEC). Insufficient capacity or incomplete electrical work may cause electrical shock or fire.
6.	Use a dedicated power circuit. Never use a power supply shared by another appliance.
7.	For wiring, use a cable that is long enough to cover the entire distance without splicing. Do not use an extension cord. Do not put other loads on the power supply; use a dedicated power circuit. Failure to do so may cause abnormal heat, electric shock or fire.
8.	Use the specified types of wires for electrical connections between the indoor and outdoor units. Firmly clamp the interconnecting wires so their terminals receive no external stresses. Incomplete connections or clamping may cause terminal overheating or fire.
9.	After joining the interconnecting and supply wiring, shape the cables so that they do not put undue force on the electrical covers or panels. Install covers over the wires. Incomplete cover installation may cause terminal overheating, electrical shock, or fire.
10.	If any refrigerant leaks out during the installation, ventilate the room. The refrigerant produces a toxic gas if exposed to flames.
11.	When installing or relocating the system, keep the refrigerant circuit free from substances other than the specified refrigerant (R410-A), such as air. The presence of air or other foreign substances in the refrigerant circuit can cause an abnormal pressure rise or rupture, which could result in injury and damage.

Installer's Guide

12. If a system pump-down is performed, turn off the associated equipment and close service valves prior to removing the refrigerant piping. Failure to do so will introduce non-condensables in the system, causing abnormal pressure in the refrigeration cycle which could lead to injury and damage.
13. Before system start-up, attach the refrigerant piping securely. Failure to do so will introduce non-condensables into the system when the compressor is running, causing abnormal pressure in the refrigeration cycle which could lead to injury and damage.
14. Establish a complete ground. Do not ground the unit to a utility pipe, arrester, or telephone ground. An incomplete ground may cause electrical shock, or fire. A high surge current from lightning or other sources may cause damage to the air conditioner.
15. If the power supply cable is damaged, it must be replaced by the manufacturer, its service agent or another qualified professional in order to avoid electrical risk during and after replacement.

CAUTION

1. Do not install the unit in a place where there is danger of exposure to flammable gas leakage. If gas leaks and builds up around the unit, it may result in fire.
2. After system installation is completed, make sure no refrigerant leakage is present.
3. This appliance is not intended for use by persons with a lack of experience and knowledge, unless they have been given adequate supervision or instruction concerning use of the appliance by a person responsible for their safety.
4. Children should be supervised to ensure that they do not play with the appliance.

NOTICE

1. Establish drain piping according to the instructions in this manual. Inadequate piping may cause flooding.
2. Tighten the flare nut according to the specified method. If the flare nut is tightened too hard, the flare nut may crack and cause refrigerant leakage.

Pre-Installation Checklist

1. Unpack and inspect each unit.
2. Check for any damage to the unit.
3. Check the model numbers to ensure a proper match.
4. Check the unit nameplate to ensure the proper electrical requirements will be met.
5. Check the installation locations to ensure the weight of the units can be supported.
6. Check the refrigerant pipe sizes and ensure they have been or will be installed according to the requirements in this manual.
7. Check the outdoor unit nameplate for electrical power supply and wiring requirements to ensure the proper wiring has been installed prior to connection.
8. Check the indoor unit for coil leakage. The pressure relief valve on the gas pipe should release pressurized nitrogen which ensures the unit has not leaked during shipping.

Product Introduction

The 15 Series Multi-Zone system utilizes inverter compressor technology, which enables the outdoor unit to send refrigerant to multiple indoor units of varying capacities. It is critical, however, that heat loss and heat gain calculations be performed to properly size the multi-zone system.

Primary Component Identification

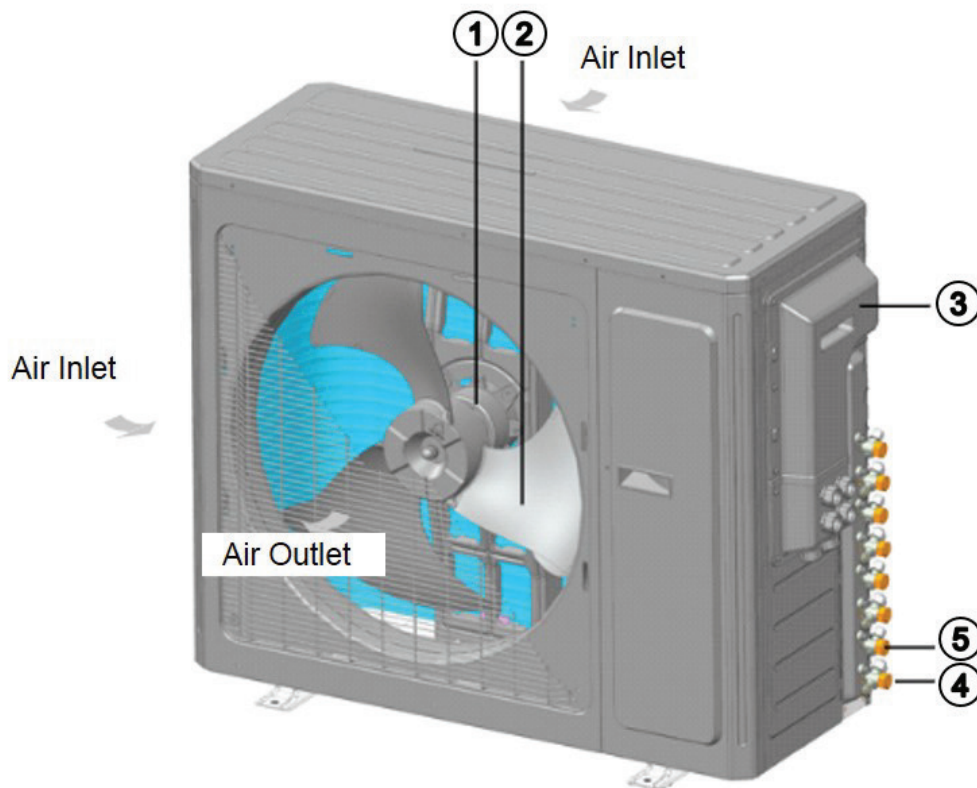

No.	1	2	3	4	5
Name	Motor	Fan	Electric Box	Gas Valve Assembly	Liquid Valve Assembly

Combinations for Outdoor and Indoor Units

MODEL	M4THM1518A	M4THM1524A	M4THM1530A	M4THM1536A	M4THM1542A
Minimum number of connectable indoor units	2	2	2	2	2
Maximum number of connectable indoor units	2	3	4	4	5

The multi-zone systems can operate with a combination ratio from 50% to 150%. This means that the total combined nominal cooling capacity of the connected indoor units can be up to 1.5 times the nominal cooling capacity of the outdoor unit.

Note: When the total capacity of the indoor units exceeds the total capacity of the outdoor unit, the system will be restricted by the capacity of the outdoor unit. All indoor units would not be able to operate at full capacity at the same time. If the indoor unit combined capacity is less than 100% of the outdoor units' capacity, the system capacity is limited to the indoor unit(s) combined capacity.

Ductless Multi-Zone Approved Combinations

Indoor Unit Combinations with Associated Nominal Capacity (kBTUH)										
Outdoor Unit	Two Units									
M4THM1518A12N 18,000 BTUH	9+9	12+12								
	9+12									
Outdoor Unit	Two Units		Three Units							
M4THM1524A13N 24,000 BTUH	9+9	9+12	9+9+9	9+12+12	12+12+12					
	9+18	12+12	9+9+12	9+9+18						
	12+18	18+18								
Outdoor Unit	Two Units		Three Units			Four Units				
M4THM1530A14N 30,000 BTUH	9+9	9+12	9+9+9	9+9+12	9+9+18	9+9+9+9	9+9+9+12	9+9+12+12		
	9+18	12+12	9+12+12	9+12+18	12+12+12					
	12+18	18+18	12+12+18							
Outdoor Unit	Two Units		Three Units			Four Units				
M4THM1536A14N 36,000 BTUH	9+9	12+18	9+9+9	9+12+18	12+12+18	9+9+9+9	9+9+12+18			
	9+12	12+24	9+9+12	9+12+24	12+12+24	9+9+9+12	9+9+18+18			
	9+18	18+18	9+9+18	9+18+18	12+18+18	9+9+9+18	9+12+12+12			
	9+24	18+24	9+9+24	9+18+24	18+18+18	9+9+9+24	9+12+12+18			
	12+12	24+24	9+12+12	12+12+12		9+9+12+12	12+12+12+12			
Outdoor Unit	Two Units		Three Units			Four Units			Five Units	
M4THM1542A15N 42,000 BTUH	9+9	12+18	9+9+9	9+12+24	12+12+24	9+9+9+9	9+9+12+24	9+12+18+18	9+9+9+9+9	9+9+9+18+18
	9+12	12+24	9+9+12	9+18+18	12+18+18	9+9+9+12	9+9+18+18	9+18+18+18	9+9+9+9+12	9+9+12+12+12
	9+18	18+18	9+9+18	9+18+24	12+18+24	9+9+9+18	9+9+18+24	12+12+12+12	9+9+9+9+18	9+9+12+12+18
	9+24	18+24	9+9+24	9+24+24	12+24+24	9+9+9+24	9+12+12+12	12+12+12+18	9+9+9+9+24	9+12+12+12+12
	12+12	24+24	9+12+12	12+12+12	18+18+18	9+9+12+12	9+12+12+18	12+12+12+24	9+9+9+12+12	9+12+12+12+18
			9+12+18	12+12+18	18+18+24	9+9+12+18	9+12+12+24	12+12+18+18	9+9+9+12+18	12+12+12+12+12

Ductless Multi-Zone Quick Reference

Multi-Zone Heat Pumps Outdoor				
18,000 BTUH	24,000 BTUH	30,000 BTUH	36,000 BTUH	42,000 BTUH
M4THM1518A12N	M4THM1524A13N	M4THM1530A14N	M4THM1536A14N	M4THM1542A15N

Multi-Zone Heat Pumps Indoor Options				
	9,000 BTUH	12,000 BTUH	18,000 BTUH	24,000 BTUH
High Wall Mounted	M4MHW1509A1N	M4MHW1512A1N	M4MHW1518A1N	M4MHW1524A1N

Combinations for Outdoor and Indoor Units

Only one of the 15 Series multi-zone outdoor units is able to support up to five indoor units. The figure below illustrates that multiple indoor high wall units may be used on a single M4THM15 multi port system, provided the combination is approved. Please reference the multi-zone approved combinations matrix on page 8.

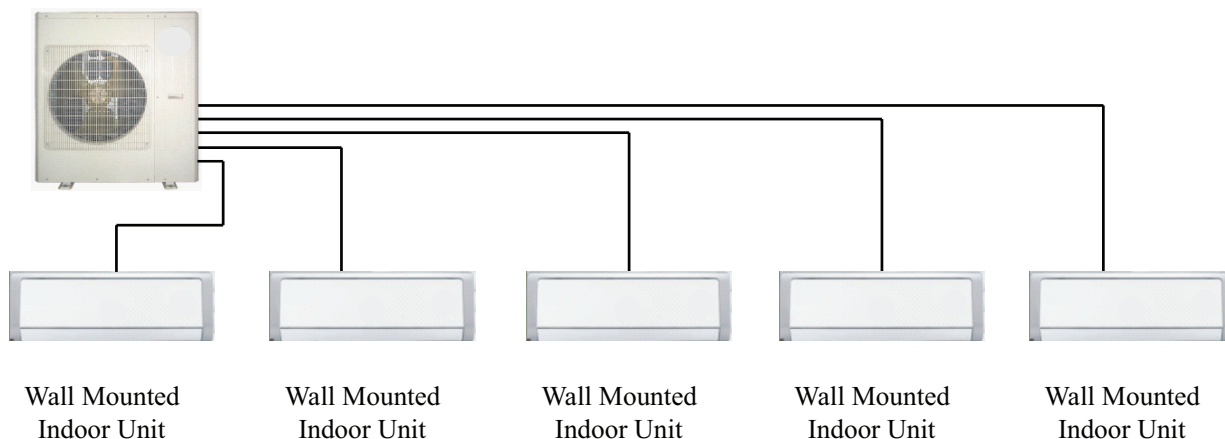

When the total capacity of the indoor units exceeds the total capacity of the outdoor unit, the system will be restricted by the capacity of the outdoor unit. All indoor units would not be able to operate at full capacity at the same time. If the indoor unit combined capacity is less than 100% of the outdoor units' capacity, the system capacity is limited to the indoor unit(s) combined capacity.

Indoor Unit	Model	Capacity	Outdoor Unit
High Wall Mounted	M4MHW1509A1N	9K Btu/h	M4THM1518A12N M4THM1524A13N M4THM1530A14N M4THM1536A14N M4THM1542A15N
	M4MHW1512A1N	12K Btu/h	
	M4MHW1518A1N	18K Btu/h	
	M4MHW1524A1N	24K Btu/h	

Operating Ranges

Cooling Operating Range	Outdoor Temperature 0 - 118°F (-18.0 - 48°C)
Heating Operating Range	Outdoor Temperature 5 - 75°F (-15 - 24°C)

Preparation for Installation

Selecting the Installation Location

Outdoor Unit

WARNING

1. Install the unit on a level surface or on supports that are level.
2. If the location is subject to strong winds, the additional force must be accounted for and the unit must be fixed securely to the base. Refer to local codes for additional requirements.

1. Select a location where equipment noise and air discharge annoyance is minimized.
2. Select a location where there is sufficient ventilation.
3. Make sure the air inlet and outlet are not blocked by any obstacles
4. Select a location capable of supporting four times the weight of the unit, that will not increase vibration, and where installation work can be carried out safely.
5. Select a location away from flammable gas or gas leaks.
6. Ensure installation of the outdoor unit conforms to the clearance specifications in this manual.
7. Locate the outdoor unit away from any bedroom windows.

NOTICE

Installing the unit in one of the following locations could result in unit malfunction:

1. Places where oil (machine oil) is used.
2. Seaside places with high levels of salt in the air.
3. Places with high levels of sulphur gas such as areas with hot springs.
4. Places where high-frequency waves are generated by radio equipment, welders and medical equipment.
5. Other unusual places where unit operation may be altered.
6. Places where minimum clearances cannot be met.

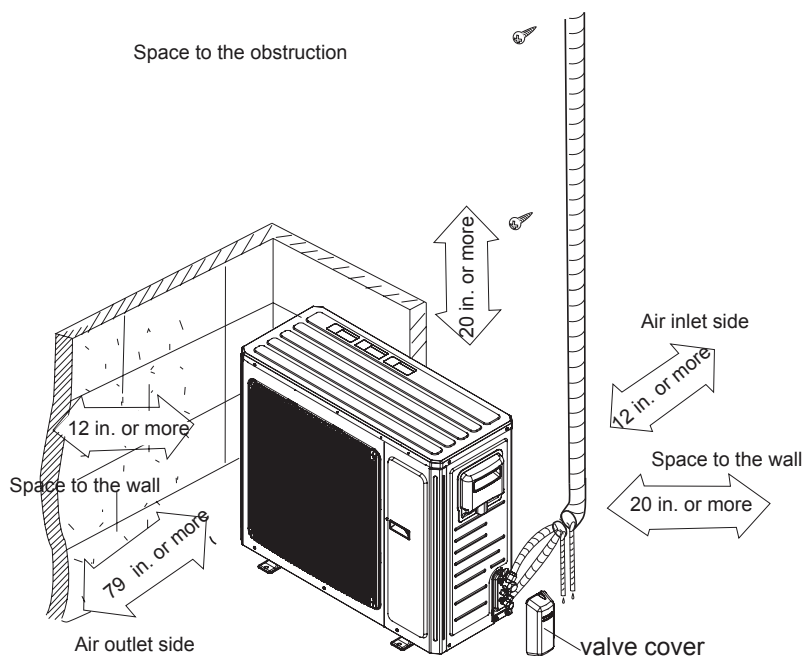

Connection Pipe Requirement

NOTICE

The maximum distance of the connection piping in both height and total length is provided in the table below. Do not install these units in locations that exceed these specifications.

Model	Connecting Pipe inch(mm)		Max. Pipe Length ft (m)	Max height difference between indoor unit and outdoor unit ft (m)	Max height difference between the lowest and highest indoor unit ft (m)
	Liquid	Gas			
M4THM1518A	1/4" (Ø 6)x2	3/8" (Ø 9)x2	75 (22.5)	20 (6)	20 (6)
M4THM1524A	1/4" (Ø 6)x3	3/8" (Ø 9)x3	230 (70)	35 (10)	25 (7.5)
M4THM1530A	1/4" (Ø 6)x4	3/8" (Ø 9)x4		35 (10)	
M4THM1536A	1/4" (Ø 6)x3 3/8" (Ø 9.5)x1	3/8" (Ø 9.5)x2 1/2" (Ø 12)x1 5/8" (Ø 16)x1		50 (15)	
M4THM1542A	1/4" (Ø 6)x4 3/8" (Ø 9.5)x1	3/8" (Ø 9.5)x2 1/2" (Ø 12)x2 5/8" (Ø 16)x1	260 (79)	50 (15)	

NOTES:

1. The connection pipes should be insulated with proper water-proof insulating material
2. Wall thickness of pipe 0.02-0.04 in (0.5-1.0 mm): bearing pressure 435 PSI (3.0 MPa).
3. Shorter connecting pipe lengths result in greater thermal efficiency, so it is preferable to reduce connecting pipe lengths where possible.
4. Refer to the oil trap instructions for specific requirements when there is height difference between the indoor and outdoor unit greater than 20 ft. (6m).

Refrigerant Piping Precautions



WARNING

Hazard of Explosion and Deadly Gases!

Failure to follow all proper safe refrigerant handling practices could result in death or serious injury. Never solder, braze or weld on refrigerant pipes or any unit components that are above atmospheric pressure or where refrigerant may be present. Always remove refrigerant by following the guidelines established by the EPA Federal Clean Air Act or other state or local codes as appropriate. After refrigerant removal, use dry nitrogen to bring system back to atmospheric pressure before opening system for repairs. Mixtures of refrigerants and air under pressure may become combustible in the presence of an ignition source leading to an explosion. Excessive heat from soldering, brazing or welding with refrigerant vapors present can form highly toxic gases and extremely corrosive acids.

NOTICE

System Component Damage!

Do not remove the seal caps from the refrigerant connections and piping until prepared to braze refrigerant pipes to the connections. Excessive exposure to atmosphere (greater than 5 minutes) may allow moisture or other particulates to contaminate the system, damaging valve seals and causing ice formation in the system components during operation.

Nitrogen Purging While Brazing

NOTICE

Avoid Unit Damage!

Never braze pipe connections without performing nitrogen purging. Failure to perform this procedure will damage the unit, resulting in capacity loss and reduced long-term reliability.

While brazing refrigerant pipes, continuously purge them with nitrogen gas. Use a pressure regulator to maintain a flow rate of 1.76 ft³/h (0.05 m³/h) or more.

Nitrogen purging while brazing refrigerant pipes

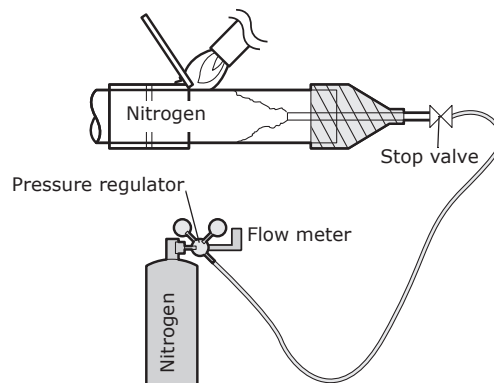

Installing the Outdoor Unit



WARNING

1. Install the unit on a level surface or on supports that are level.
2. If the location is subject to strong winds, the additional force must be accounted for and the unit must be fixed securely to the base. Refer to local codes for additional requirements.

When the outdoor unit is surrounded by walls or other obstructions, the installation space of the unit should be no less than the clearances indicated below. For efficient operation, leave three of four directions of peripheral constructions open when possible.

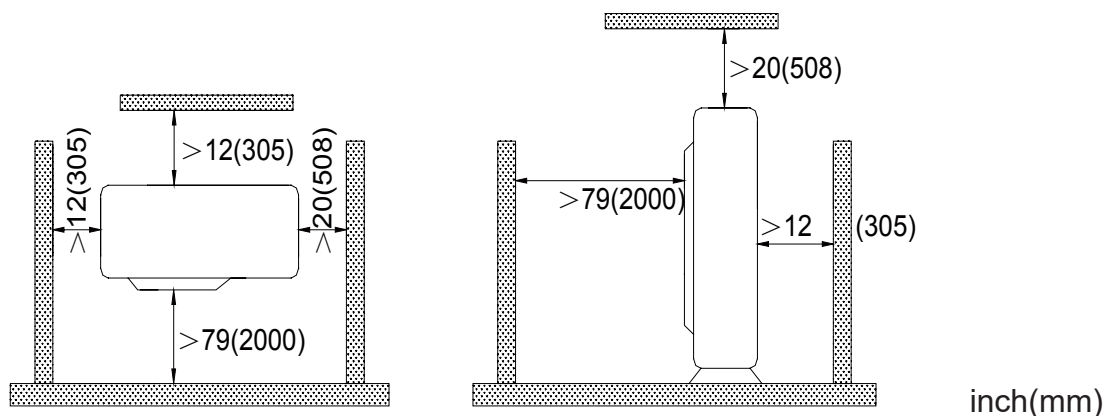

Select the installation location that provides easy access to the indoor unit.

1. Make sure the location can support at least four times the weight of the unit.
2. Secure the outdoor unit on the selected base location with expansion screws.
3. The outdoor unit should be installed at least 1 1/4 inch above the ground or base in order to install a drain pipe and connector (shown below).

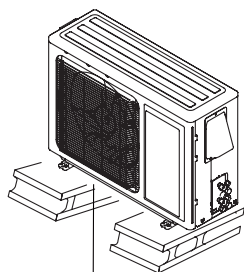

At least 1 1/4 inch (31.8mm) clearance

Condensate Management of the Outdoor Unit

1. The outdoor unit(s) should be located where condensate poses no hazard or safety risk. Each unit is supplied with a drain pipe connector.
2. Before installing the drain pipe fitting, appropriately plug all other base pan holes not used.
3. Install the drain pipe fitting into the appropriate hole located at the base of the unit and then connect the drain pipe to it.

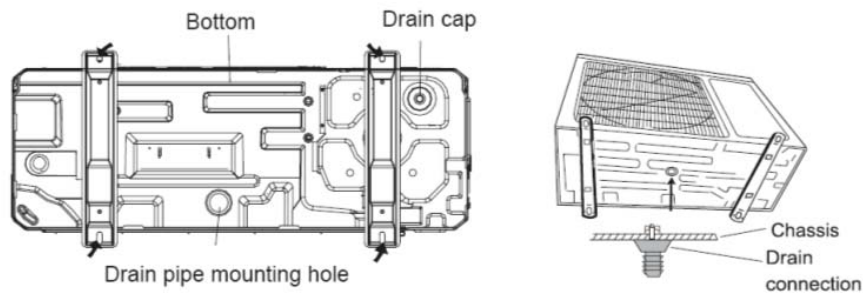

4. Place the outdoor unit on the support base.
5. Secure the foot holes of the outdoor unit with bolts (shown below).

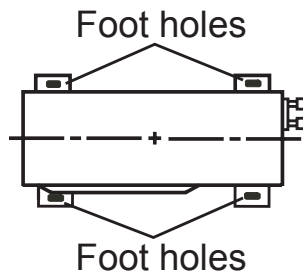

Installing the Refrigerant Piping

Flaring Process

1. Hold the pipe downward to prevent cuttings from entering the pipe.
2. Using an appropriate tube cutter and deburring tool, cut and deburr the refrigerant pipe.
3. Remove the flare nuts at the stop valve of the outdoor unit and inside the accessory bag of the indoor unit, put them onto the refrigerant pipe as shown below then flare the refrigerant pipe with a flaring tool.
4. When flaring copper tubing, only use flaring tools that utilize an orbiting mandrel and clutched handle. These are typically referenced as R410A flaring tools. By using this type of flaring tool, the copper tubing is rolled while being pressed, thereby reducing the probability of copper flare cracking.
5. Check if the flare part is spread evenly and there are no cracks.

Bending Pipes

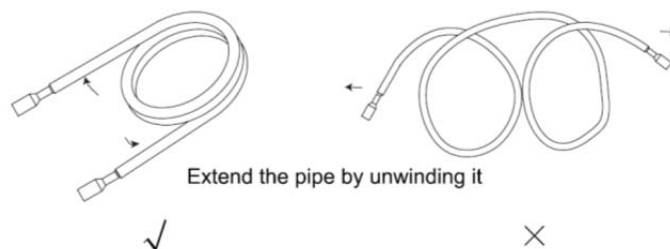

1. Use a refrigerant pipe bending tool to shape refrigerant piping; smaller diameter piping may allow for light hand bending, providing minimum diameter of 6 inches.
2. Do not bend the pipes in an angle more than 90°.
3. When pipes are repeatedly bent or stretched, the material will be prone to damage, which may lead to refrigerant leaks. Do not bend or stretch the pipes more than three times.

- Do not bend the pipe while insulated. First, cut the insulation with a sharp cutting tool and expose it to the appropriate bend radius, as shown below. After bending the pipe, replace the insulation and seal it with pipe wrap tape.

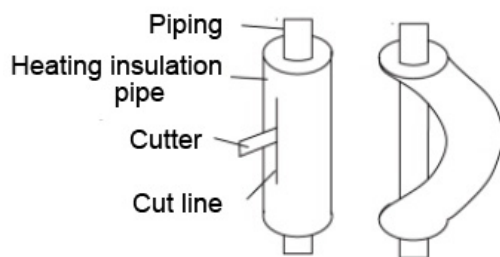

NOTICE

- To prevent distortion and breaking of the pipe, bend the pipe with a radius of curvature of 6 in. (150 mm) or more. Use a tubing bender when forming the copper tubing into a bend.
- If the pipe is bent repeatedly at the same place, it will break.

CAUTION

Connect the gas pipe after connecting the liquid pipe completely.

Insulating the Refrigerant Piping and Connections

- The refrigerant pipes should be insulated and wrapped with appropriate insulating material and wrapping tape. This will prevent condensation, water leakage and damage to the insulating material.
- The connections at the indoor unit should be wrapped with insulating material. No gap is allowed on the joint of the indoor unit, as shown below.

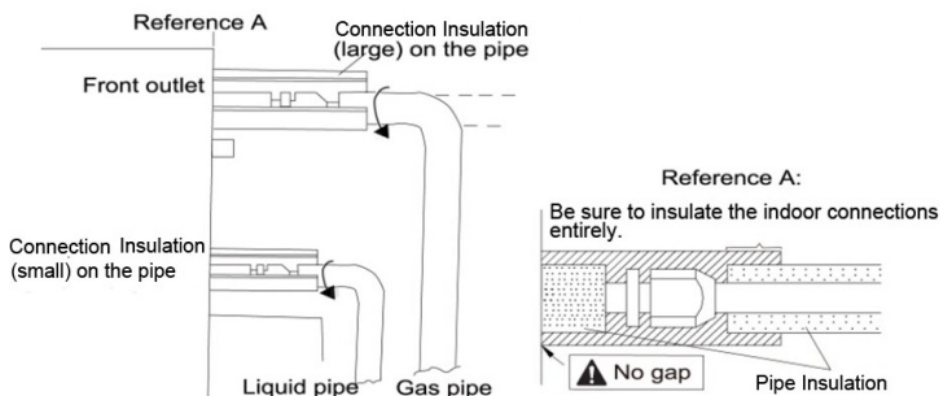

Refrigerant Piping at the Indoor Units

Reference the Indoor Unit Installation Guide.

Refrigerant Piping at the Outdoor Unit

Tighten the flare nut of the connection pipe at the outdoor unit valve connector. Follow the flare nut guidelines in this manual.

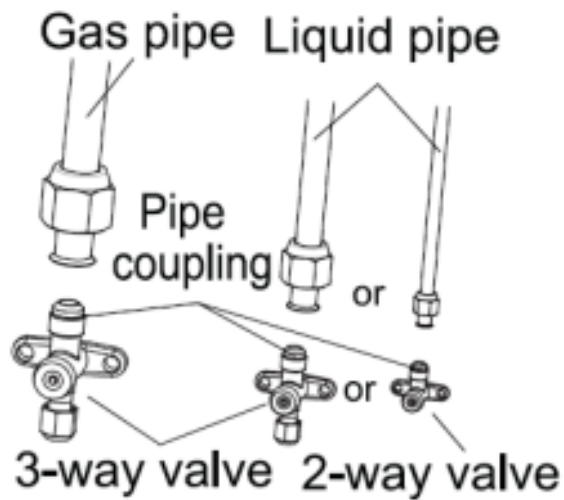

Torque Reference Table		
Pipe Diameter in. (mm)	Tube Thickness in. (mm)	Tightening Torque
1/4" (6.35)	≥ 0.03 (0.8)	11.25 - 14.75 lb•ft (15 ~ 20 N•m)
3/8" (9.52)	≥ 0.03 (0.8)	22.25 - 29.50 lb•ft (30 ~ 40 N•m)
1/2" (12.7)	≥ 0.03 (0.8)	33.25 - 40.50 lb•ft (45 ~ 55 N•m)
5/8" (15.9)	≥ 0.04 (1.0)	44.25 - 47.75 lb•ft (60 ~ 65 N•m)

Piping Requirements

If the outdoor unit is installed lower than the indoor unit:

1. A drain pipe should be above ground and the end of the pipe should not dip into water.
2. Taping pipes must be done from bottom to top. Do not wrap too tightly to avoid compression of the insulation, otherwise its effectiveness is reduced.
3. All pipes are bound together by pipe tape and secured to the wall with saddles.
4. NOTE: Oil traps are sometimes needed when the outdoor unit is installed lower than the indoor unit. One oil trap is required for each 33 ft. (10m) of vertical gas pipe length.

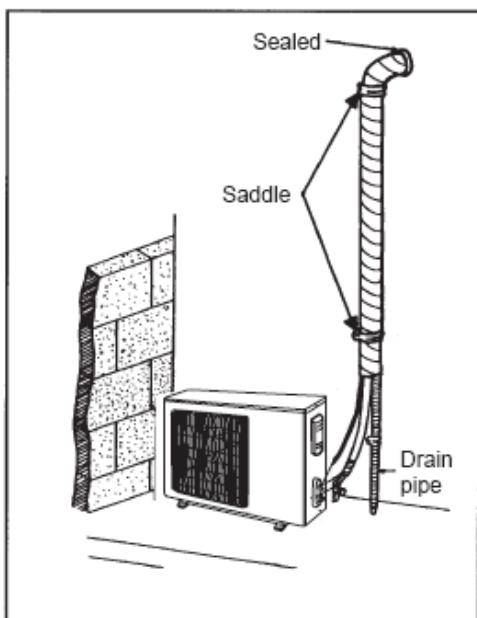

Outdoor Unit Installed Lower than Indoor Unit

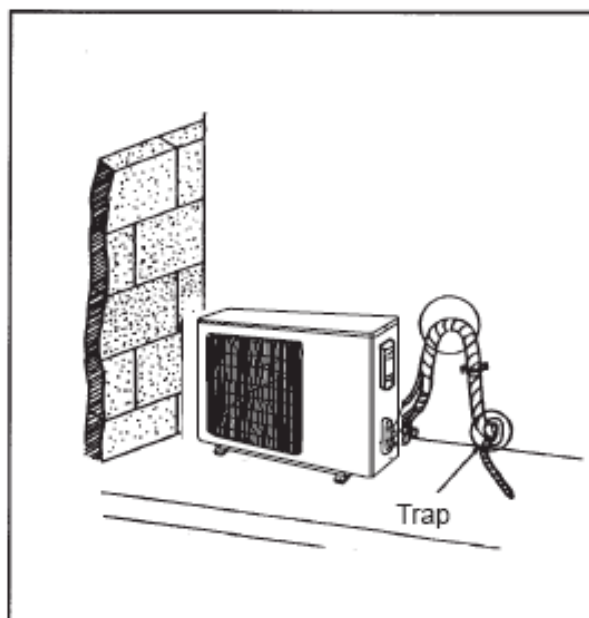

Outdoor Unit Installed Higher than Indoor Unit

If the outdoor unit is installed higher than the indoor unit:

1. Taping should be done from the lower to the upper part. Do not wrap too tightly to avoid compression of the insulation, otherwise its effectiveness is reduced.
2. All pipes are bound and taped together and also should be trapped to prevent water from returning to the room.
3. Secure all pipes to the wall with saddles.
4. NOTE: Oil traps are sometimes needed when the outdoor unit is installed higher than the indoor unit. An oil trap is needed for each 20 ft. (6m) of vertical rise on the gas pipe.

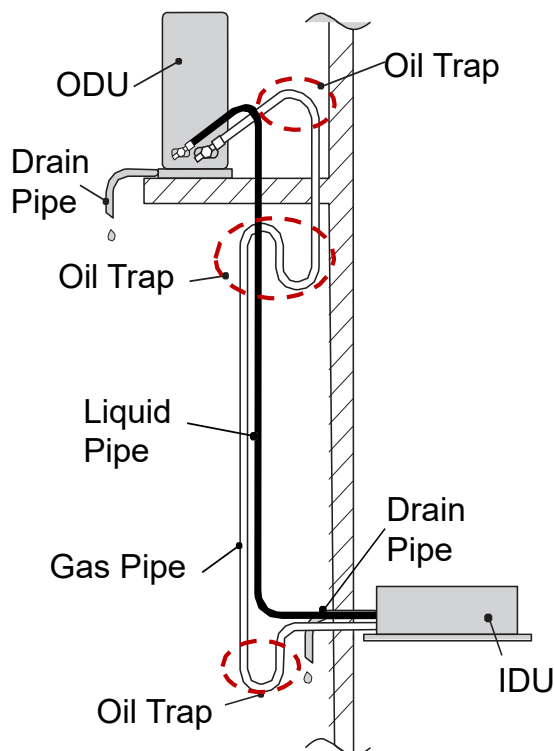

Refrigerant Piping Between the Indoor and Outdoor Units

All indoor units are individually connected to ports at the outdoor unit (As shown below).



- If any refrigerant ports are not connected to indoor units, please tighten the cap to seal off the port. Paired ports are labeled A, B, C, D, and E.
- During the connection of the indoor unit and the refrigerant pipe, never pull any joints of the indoor unit by force, otherwise the pipes may crack which would then result in leakage.
- The refrigerant pipe should be supported by brackets, don't let the unit withstand the weight of the pipe length. If the piping connection size of the outdoor unit does not match the piping connection size of the indoor unit, use the piping connection dimension of the indoor unit. Use a connection joint that will accommodate the transition.
- Each pipe should be labeled to tell which indoor system it belongs to avoid mistaken or inaccurate piping connections.

Charging Instructions	M4THM1518A		M4THM1524A		M4THM1530A		M4THM1536A		M4THM1542A	
	ft	m	ft	m	ft	m	ft	m	ft	m
Maximum total length (a+b+c+d+e)	75	20.5	230	70	230	70	230	70	260	79
Maximum length to any single indoor unit (Lx)	33	10	65	20	65	20	65	20	80	24
Minimum length to any single indoor unit	10	3	10	3	10	3	10	3	10	3
Maximum height difference between outdoor unit and any indoor unit *(H1)	20	6	35	10	35	10	50	15	50	15
Maximum height difference between indoor units *(H2)	20	6	25	7.5	25	7.5	25	7.5	25	7.5
Maximum total pipe length before adding charge is required	66	20	100	30	130	40	130	40	165	50
Minimum total pipe length before removing charge is required	33	10	50	15	65	20	80	24	100	30
Amount of R410-A to add or remove	oz/ft	g/m	oz/ft	g/m	oz/ft	g/m	oz/ft	g/m	oz/ft	g/m
	0.22	20	0.22	20	0.22	20	0.24	22	0.24	22

* This height difference limit applies regardless of whether the indoor unit or outdoor unit is higher.

Note: Refer to diagram on page 17.

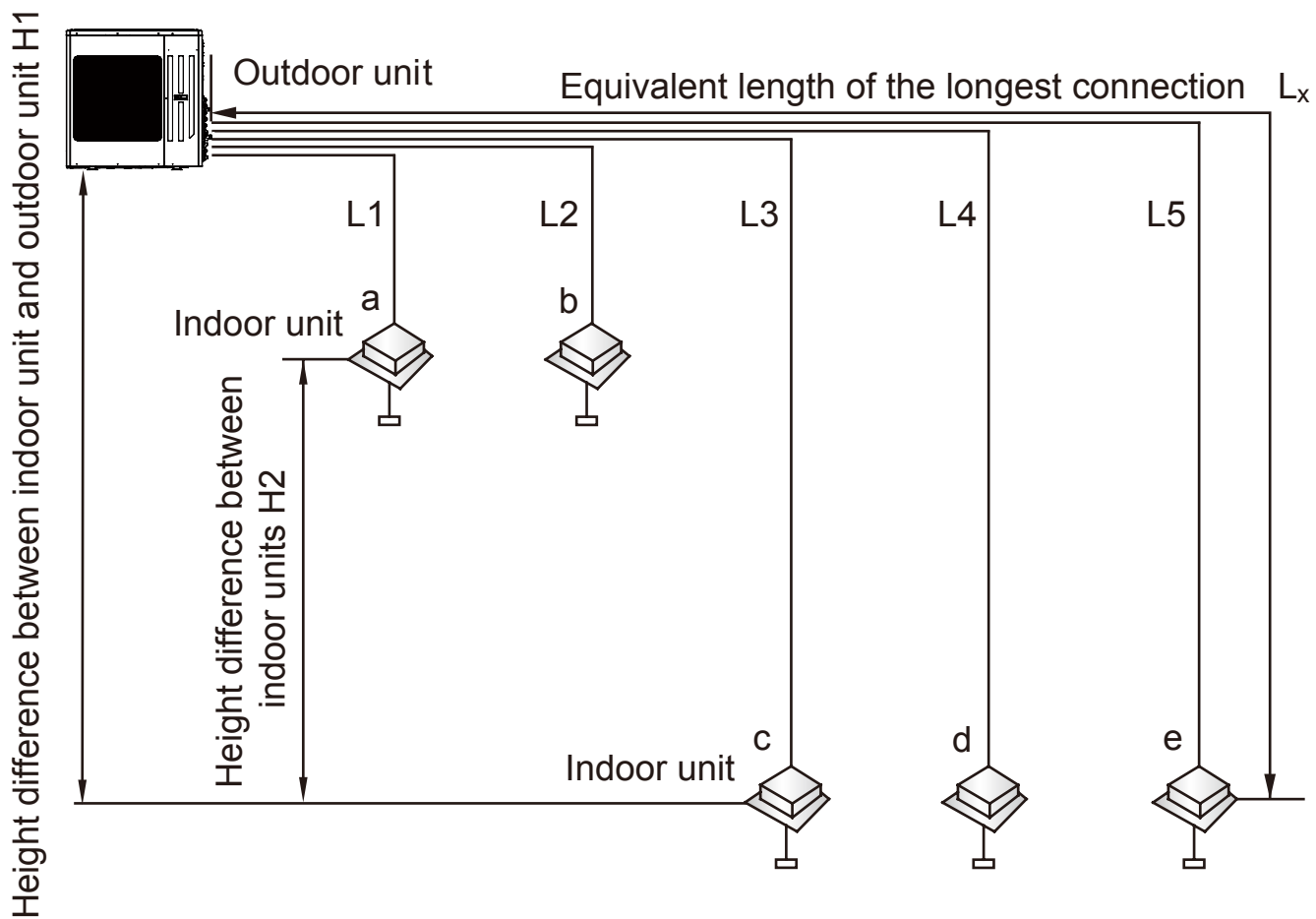

Vacuum and Refrigerant Leakage Detection

NOTICE

Do not purge the air with refrigerant. Use a vacuum pump to vacuum the installation!

1. When connecting refrigerant pipe to the unit or removing it from the unit, please use both a back-up wrench and the torque wrench.
2. When connecting, place the equipment specified oil type on the backside of the copper tube flare prior to tightening. Do not place oil on the flare face, as this will promote system contamination, tighten it by hand and then tighten it with the spanner or adjustable wrench.
3. Refer to the torque reference table within this document before tightening to determine the appropriate torque (over-tightening will damage the nut and lead to leakage).
4. Use dry Nitrogen to pressurize the piping circuit with 150 PSIG and allow it to hold while performing other installation processes. It is recommended to apply a soap bubble solution and observe the connection.
5. Evacuate each individual refrigeration circuit to 350 microns or below, and close off the valve to the vacuum pump. If the pressure rises above 500 microns within one minute, but not above 1500 microns within 5 minutes, moisture is present. If the pressure continues to rise above 1500 microns, a leak exists in the circuit being tested.
 - a) If moisture is present, use triple evacuation process to eliminate the moisture.
 - b) If a leak is present, leak check all joints and piping.

Evacuation is not completed until the micron gauge does not rise above 500 microns within one minute after achieving 350 micron pressure vacuum.
6. After evacuation is complete, additional charge is to be added.
 - a) If no additional charge is required, break the vacuum with refrigerant, then remove the gauge connectors.
 - b) slightly open the liquid valve at the outdoor unit, allow system to equalize, then fully open the liquid valve and then open the vapor service valve.
7. After leak checking is complete, apply thermal insulation around the flare connections and all exposed refrigeration pipes.
 - a) Seal the insulation.
 - b) Inspect the insulation to ensure no breakages are present.

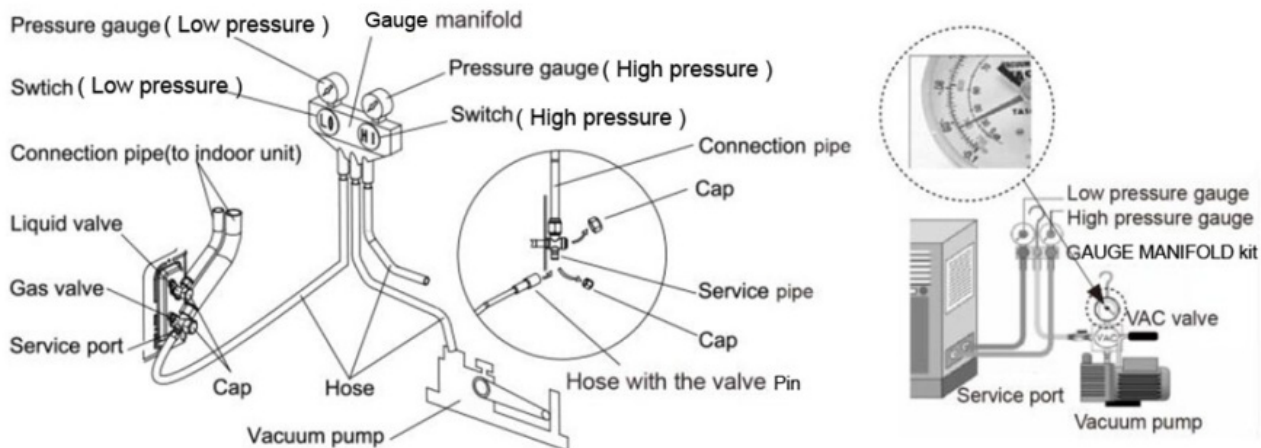

Wiring Precautions



WARNING

1. Before obtaining access to terminals, all supply circuits must be disconnected.
2. Improperly installed and grounded field wiring poses fire and electrocution hazards. For high voltage connections, flexible electrical conduit is recommended whenever vibration transmission may create a noise problem within the structure. To avoid these hazards, you **MUST** follow requirements for field wiring installation and grounding as described in the National Electrical Codes (NEC) and your local/state electrical codes. All field wiring **MUST** be performed by qualified personnel. Failure to follow these requirements could result in death or serious injury.

Electrical Notes:

1. EACH unit should be installed with its own dedicated power supply source. The power source needs to be sized correctly for the unit capacity.
2. The rated voltage of the unit is as shown in this manual.
3. Before turning on, verify that the voltage is within the 187~252 V range (for 208/230 V, single phase units).
4. Always use a grounded terminal and install a separate receptacle to supply power to the air conditioner. For high voltage connections, flexible electrical conduit is recommended whenever vibration transmission may create a noise problem within the structure.
5. Use a dedicated breaker and receptacle matched to the capacity of the air conditioner.

Outdoor Wiring Connections

1. Remove the wire clip and connect the power connection wire and signal control wire terminals according to the color coding.
2. Attach the wires to the terminals and make sure they are securely fastened. Refer to wiring diagrams in this manual. An example is provided in the figure below:

M4THM1518A

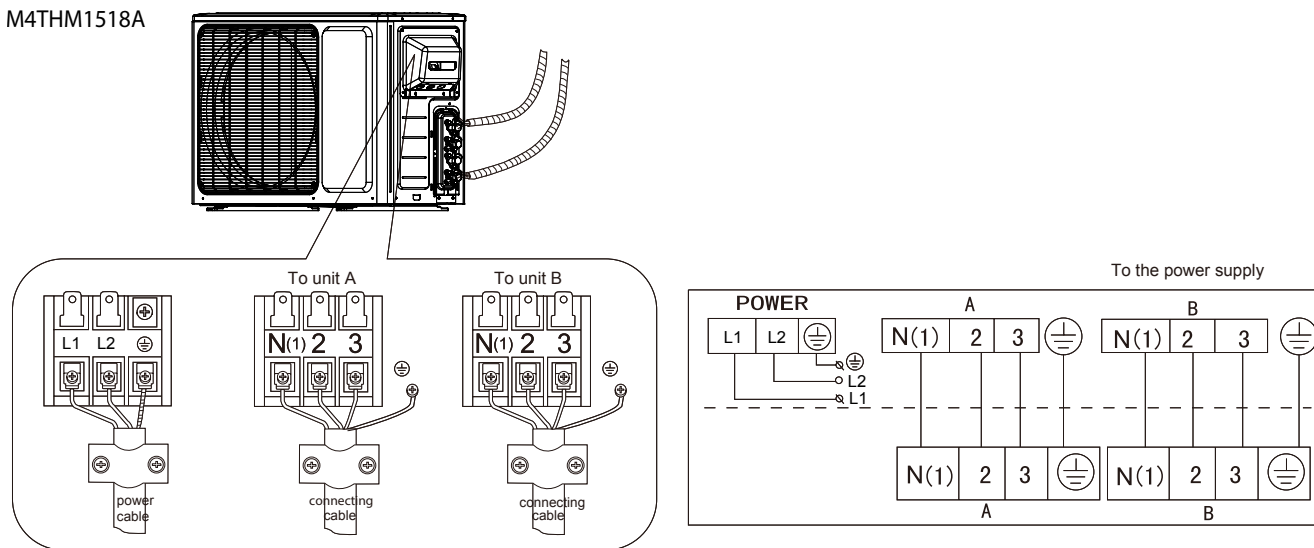

NOTE: The wiring diagrams in this guide are included as a reference. The manufacturer has a policy of continuous product and product data improvement and reserves the right to change design and specifications without notice. Always check the unit nameplate and wiring diagram for the actual unit requirements.

Stranded Wiring Connections

Cut the wire end with a wire cutter or wire cutting pliers, then strip the insulation about 3/8" (10mm).

1. Using a screwdriver, remove the terminal screw(s) on the terminal board.
2. Using a round terminal fastener or pliers, securely clamp a round terminal to each stripped wire end.
3. Position the round terminal wire, and replace and tighten the terminal screw with a screwdriver.
4. Affix and secure the power supply and connection wiring under unit wiring clamps.

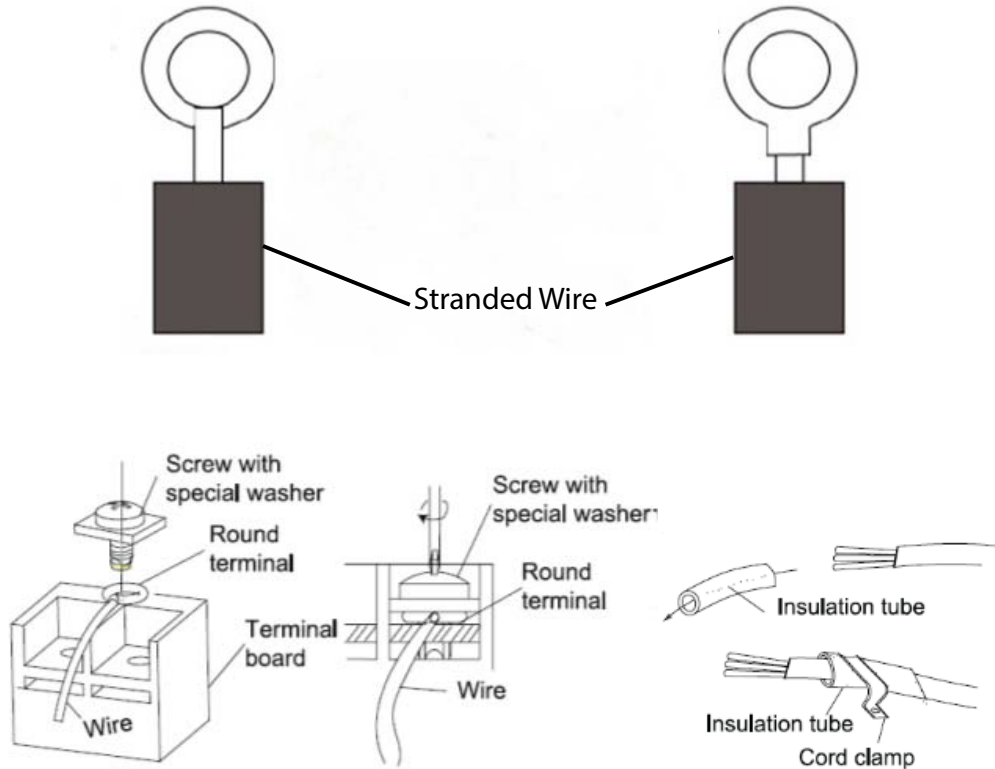

WARNING

1. Ensure power supplied to the equipment (both indoor and outdoor units) is disconnected and the units are not energized prior to performing work on the system.
2. Improperly installed field wiring poses fire and electrocution hazards. Install wiring carefully.
3. Secure the connection wires firmly to the terminal block. Improper installation may cause a fire.
4. Always fasten the outside covering of the connection wire with wire clamps. If the insulator is not clamped, electric leakage may occur.
5. Always completely connect the ground wire.

Note:

Match the terminal block numbers and connection wire colors with those of the indoor units.

Electrical Connections

CAUTION
Improper operation may lead to personal injury or property damage.
Size the power supply wiring according to the NEC, local code and the MCA indicated on the unit nameplate.

Electrical Requirements

Models	Power Supply
M4THM1518A	208/230V, 60Hz, 1phase
M4THM1524A	
M4THM1530A	
M4THM1536A	
M4THM1542A	

1. Always check the unit nameplate for the MCA and MOP requirements.
2. The fuse is located on the main electrical board.
3. A dedicated indoor unit disconnect switch and power supply circuit may need to be installed if local codes or jurisdictions require it. Otherwise, the indoor unit is powered directly from the outdoor unit.
4. Install a separate disconnect at the outdoor unit. The power supply, wiring and grounding of equipment must comply with National, State and/or local codes. The power supply must match with the equipment nameplate specification.
5. Improperly installed and grounded field wiring poses fire and electrocution hazards. For high voltage connections, flexible electrical conduit is recommended whenever vibration transmission may create a noise problem within the structure. To avoid these hazards you **MUST** follow requirements for field wiring installation and grounding as described in the National Electrical Codes (NEC) and your State and/or local electrical codes. All field wiring **MUST** be performed by qualified personnel. Failure to follow these requirements could result in death or serious injury.
6. The wiring, including the ground wire, between the indoor and outdoor units should be at least 14 AWG, 600 volt rated, stranded wire, with an absolute maximum length of 230 ft. (70m). Shorter lengths result in more robust communication between the indoor and outdoor unit. Please select an appropriate length for the installation conditions. The wires cannot be cut and spliced together.
7. For the wired controller: The communication distance between the main board and the wired controller can be up to 65 ft. (19.8m). The standard distance is 25 ft. (7.6m).

Power Supply Wiring

1. Open the side covering plate.
2. Connect the power wiring to the terminals "L1", "L2" and also to the grounding bolt, and then connect the wiring terminals "N(1), 2, 3" of the indoor unit to those of the outdoor unit correspondingly.
3. Fix the power wiring with wire clips.
4. Run the power wiring through conduit (as required by NEC) attached to the round electrical connection ports.

Note: When connecting the power supply wiring, make sure that the phase of the power supply matches with the voltage and phase on the nameplate, If not, the compressor will run improperly.

Cable Specifications

The wiring, including the ground wire, between the indoor and outdoor units should be at least 14 AWG, 600 volt rated, stranded, four conductor wire, with an absolute maximum length of 230 ft. (70m). Shorter lengths result in more robust communication between the indoor and outdoor unit. Please select an appropriate length according to the installation conditions. The wires cannot be cut and spliced together.

Consult local and regional codes, as well as the NEC, for installation requirements that are applicable to the selected type of cable including watertight conduit and raceway requirements.

Power supply wiring should be installed according to the NEC, local and regional codes. Refer to the equipment nameplate for electrical requirements.

Grounding Requirements

- Follow your local, State and National Electric Codes (NEC) when grounding this unit.
- The air conditioner is classified as a Class I appliance and must be grounded.
- The yellow-green wire of the air conditioner is the ground wire and cannot be used for other purposes or cut off, otherwise it would create an electric shock hazard.
- Do not ground the unit to a utility pipe, arrester or telephone ground. Incomplete ground may cause electrical shock or fire. A high current surge from lightning or other sources may cause damage to the air conditioner.

Installation of Controllers

Refer to the controller installation manual for instructions and functionality.

Post Installation Checklist

Check the following points before testing the unit:

NO.	Item to be checked	Possible problem
1	Have the indoor and outdoor units been securely installed?	The units may fall, vibrate or make noise.
2	Has the refrigerant leak test been completed?	Unresolved leaks may cause insufficient cooling or heating.
3	Have the pipes been properly insulated?	Lack of insulation may cause condensation and water damage.
4	Is the water condensate drainage sufficient?	Lack of proper drainage may cause condensation and water damage.
5	Does the voltage of the power supply comply with the voltage on the nameplate?	Incorrect power supply can create malfunction and fire or electrocution hazard.
6	Is the electric wiring and drain piping installed correctly?	Improper wiring and drainage can create a malfunction, fire or electrocution hazard and water damage to the unit and property.
7	Is the unit grounded properly?	Improper grounding can cause malfunction and fire or electrocution hazard.
8	Does the power wiring match the unit requirements?	Improper wiring can create malfunction and fire or electrocution hazard.
9	Are there any obstructions near the air inlets and air outlets for the indoor and outdoor units?	Improper ventilation and airflow will cause insufficient cooling and heating and possible freezing and condensate issues at the indoor unit.
10	Have dust and debris been cleaned and removed from the installation site?	Excessive dust and debris in and around the units may cause a malfunction or damage to the units.
11	Are the gas valve and liquid valve of the connection pipes open completely?	Restricted refrigerant flow may cause insufficient cooling or heating.

Test Operation:

1. Turn on main power to the units.
2. Using the remote control, press the ON/OFF button to start operation.
3. Press the MODE button to select and test each option for normal operation. Cycle through all functions: AUTO, COOL, DRY, FAN and HEAT (heat pump models only).
4. Note: When conducting this test, be mindful of the modes of operation and the ambient temperature ranges specified in this manual.
5. Instruct the end-product user about basic operating, maintenance and troubleshooting functions.

Refrigerant System Diagram 18K, 24K, 30K

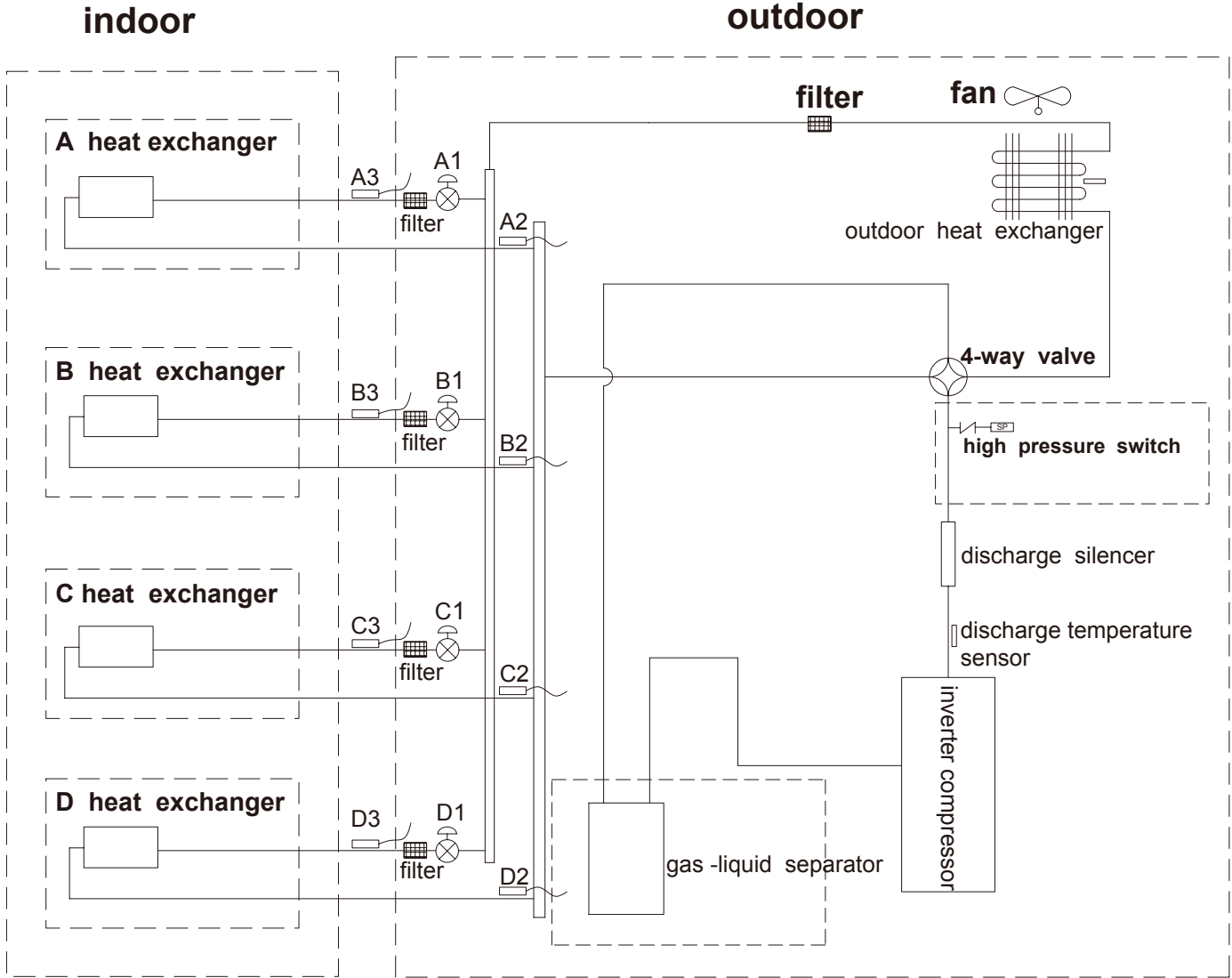

Refrigerant System Diagram 36K, 42K

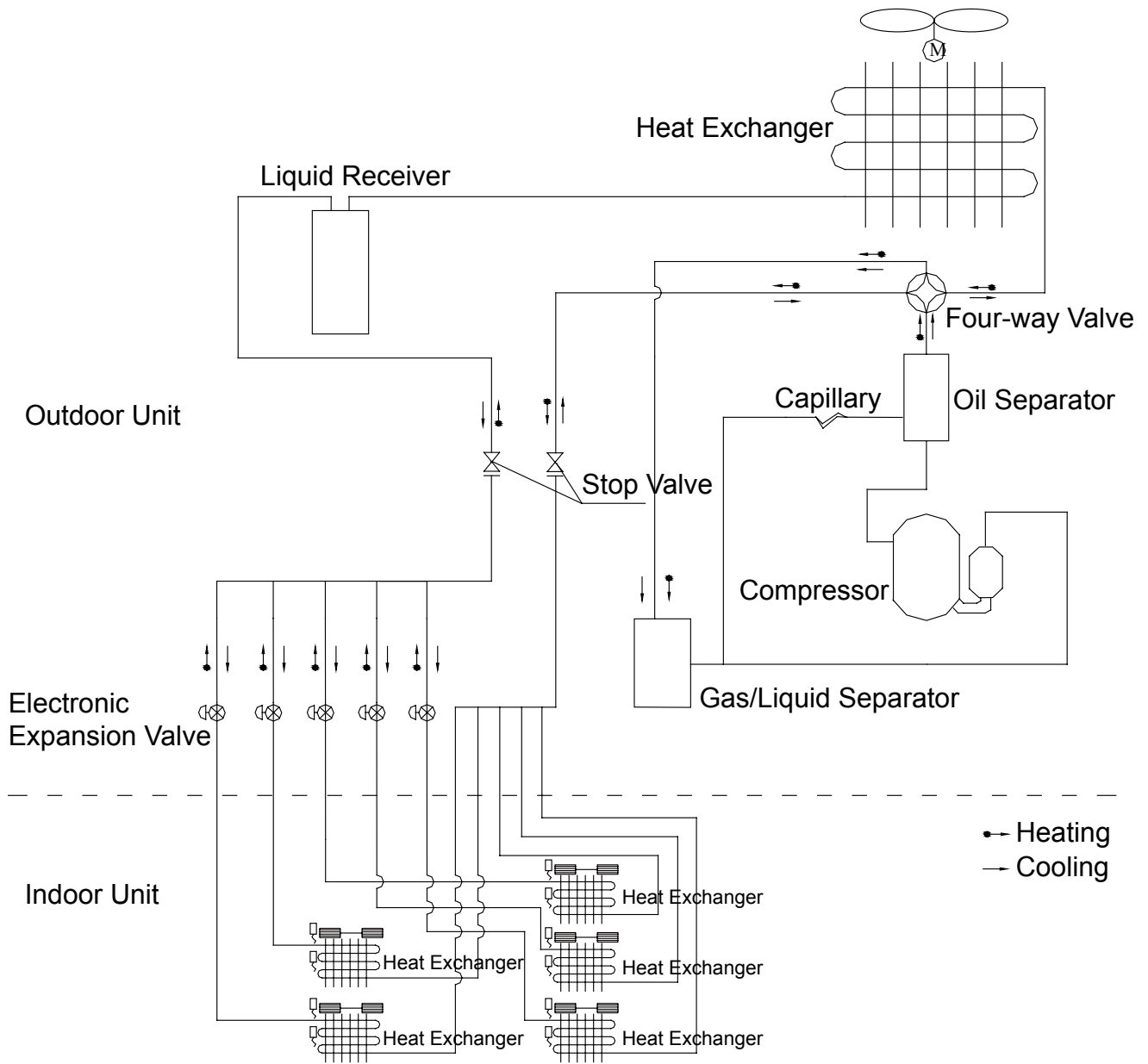

Electrical Connections at the Outdoor Unit

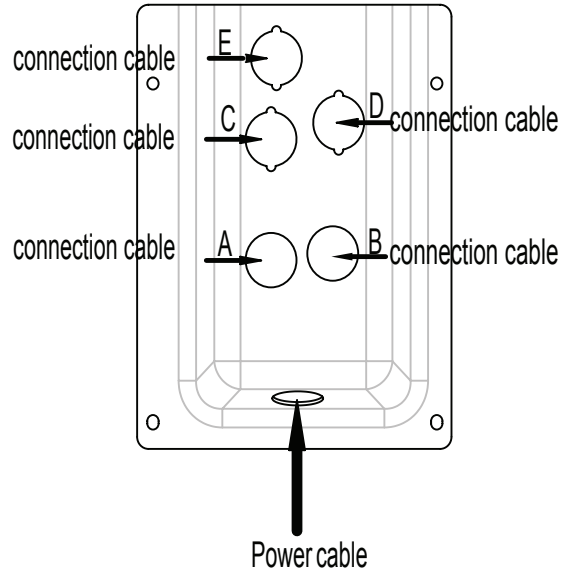
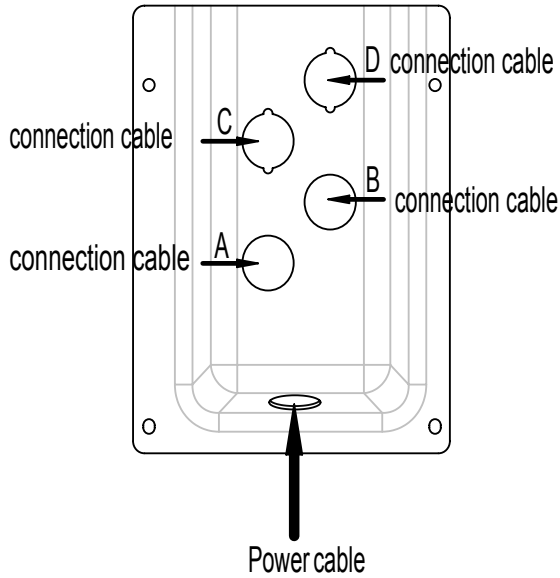

1. The power cable should be put in from the hole under the connection cable cover.
2. If connecting with two indoor units, the connection cable should be put in from hole A and B.
3. If connecting with three indoor units, the connection cable should be put in from hole A, B and C.
4. If connecting with four indoor units, the connection cable should be put in from hole A, B, C and D.
5. If connecting with five indoor units, the connection cable should be put in from hole A, B, C, D and E.
6. All power cables and connections must be protected with conduits and fastened securely to avoid loosening and electric shock hazard.
7. All connection ports might not be used, depending on the number of indoor units. Leave knockouts intact if the port is not needed.

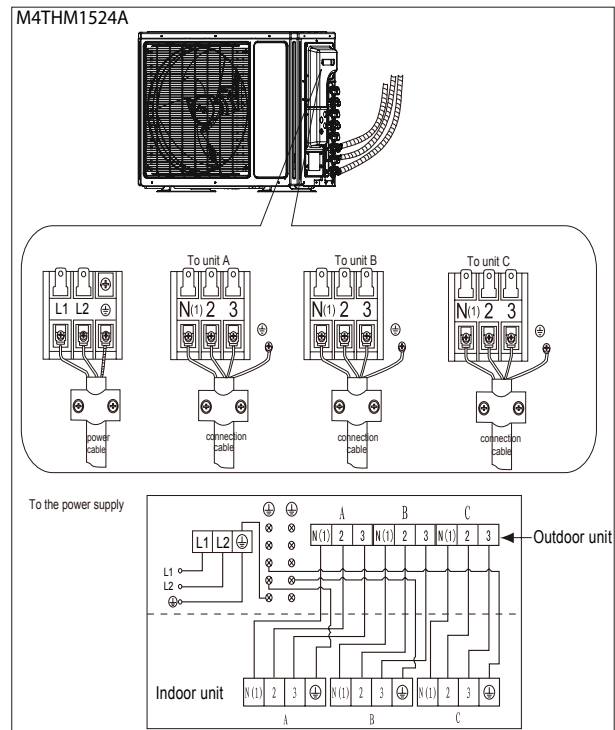
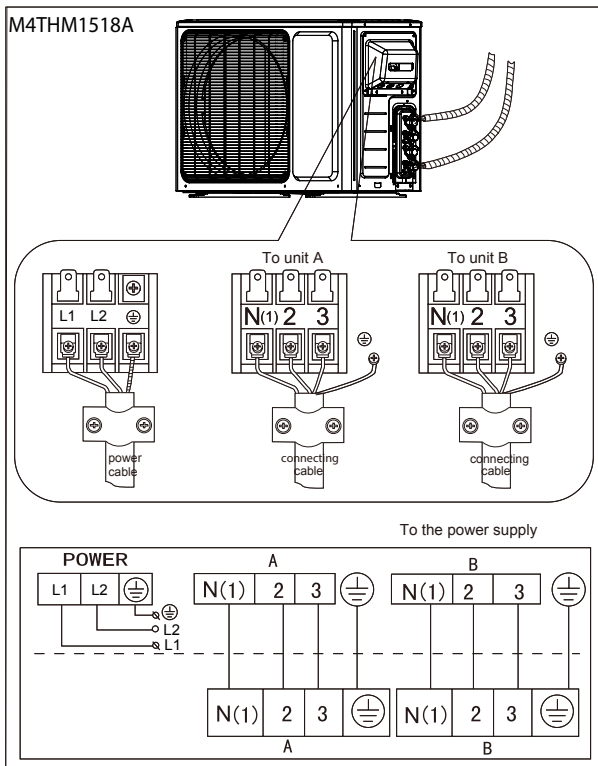

Electrical Connections at the Outdoor Unit

M4THM1530A, M4THM1536A

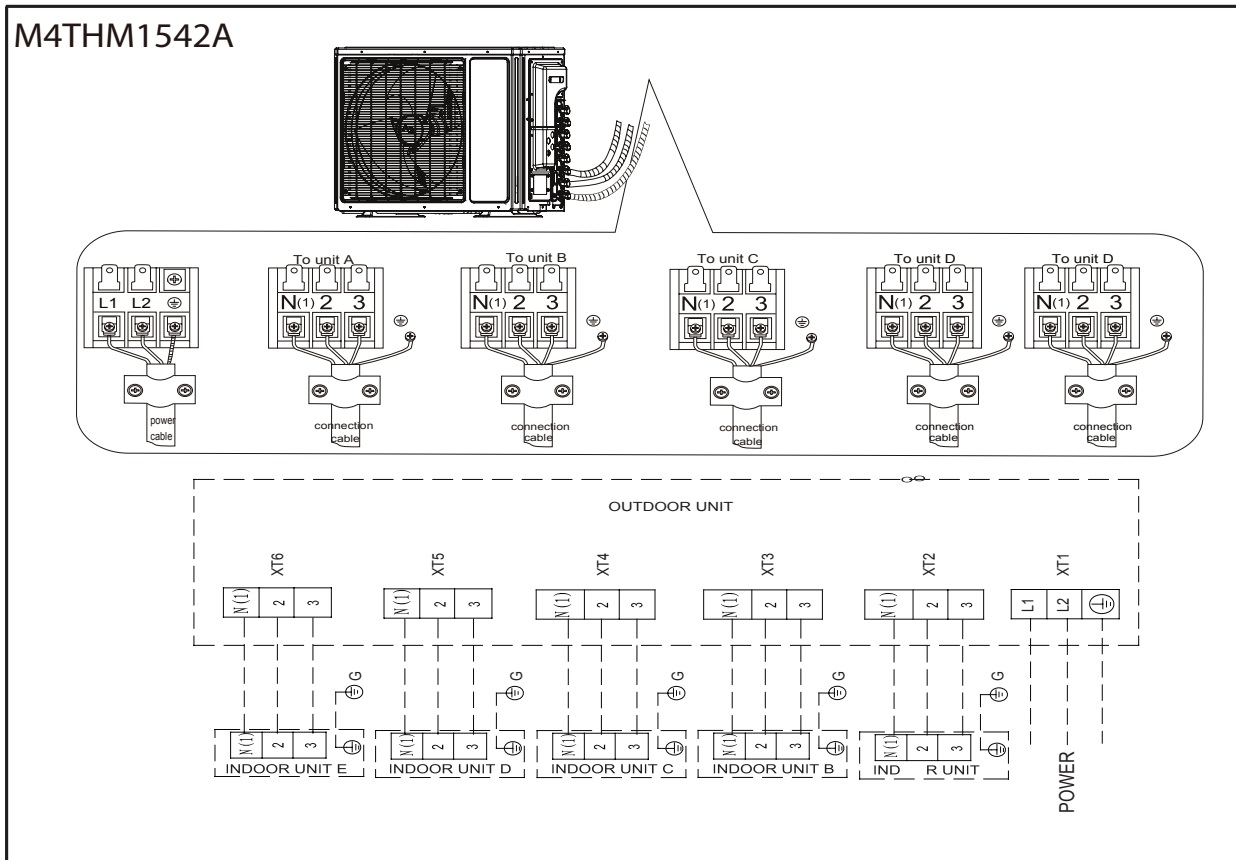
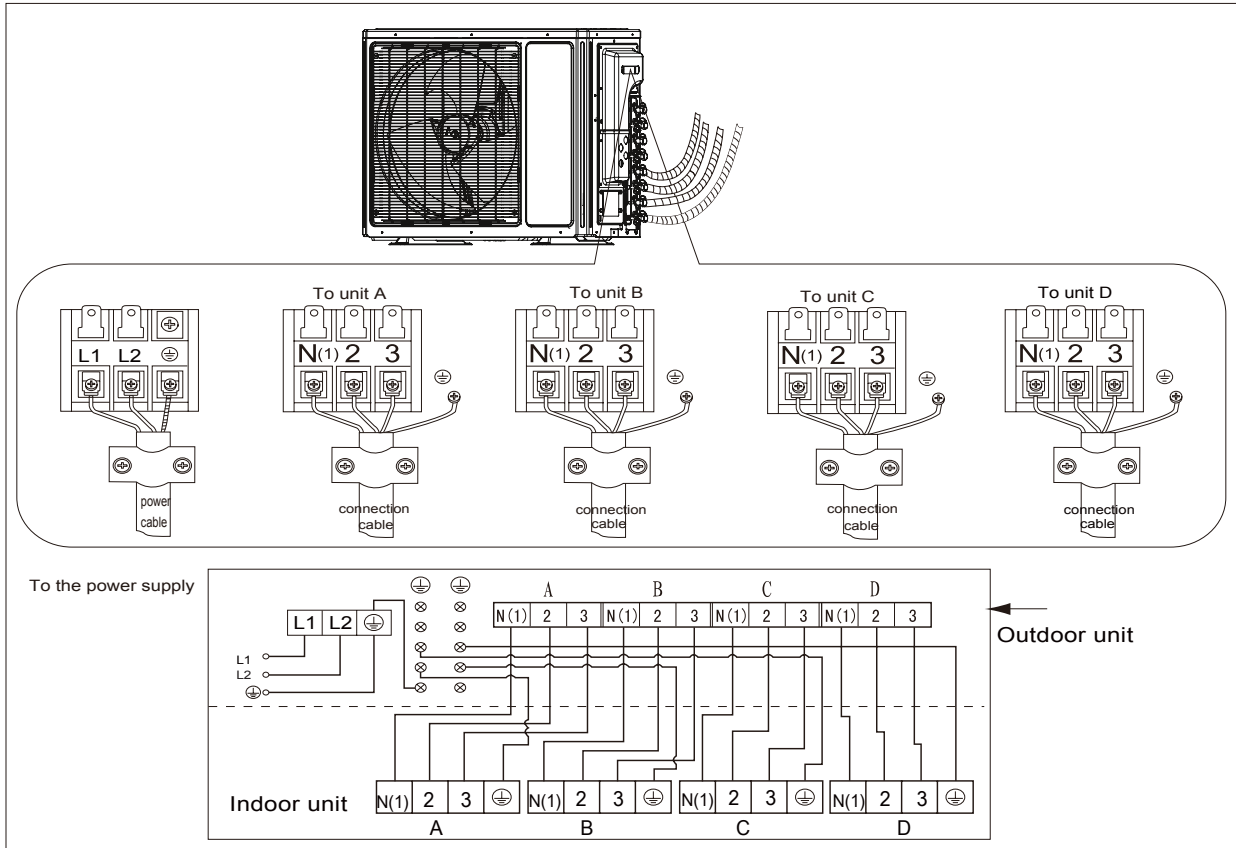

Wiring Diagrams

Color Key

Symbol	Symbol Color	Symbol	Symbol Color	Symbol	Name
WH	White	GN	Green	COMP	Compressor
YE	Yellow	BN	Brown		Grounding wire
RD	Red	BU	Blue		
YE/GN	Yellow/Green	BK	Black		
VT	Violet	OG	Orange		

Note: A "Jumper Cap" may be used to determine fan speed and the swing angle of horizontal louver for this model. The unit will not operate without the correct jumper cap. If "Jumper Caps" are installed on the original electrical board, they must be removed and installed on a replacement electrical board.

Wiring Diagram 18K

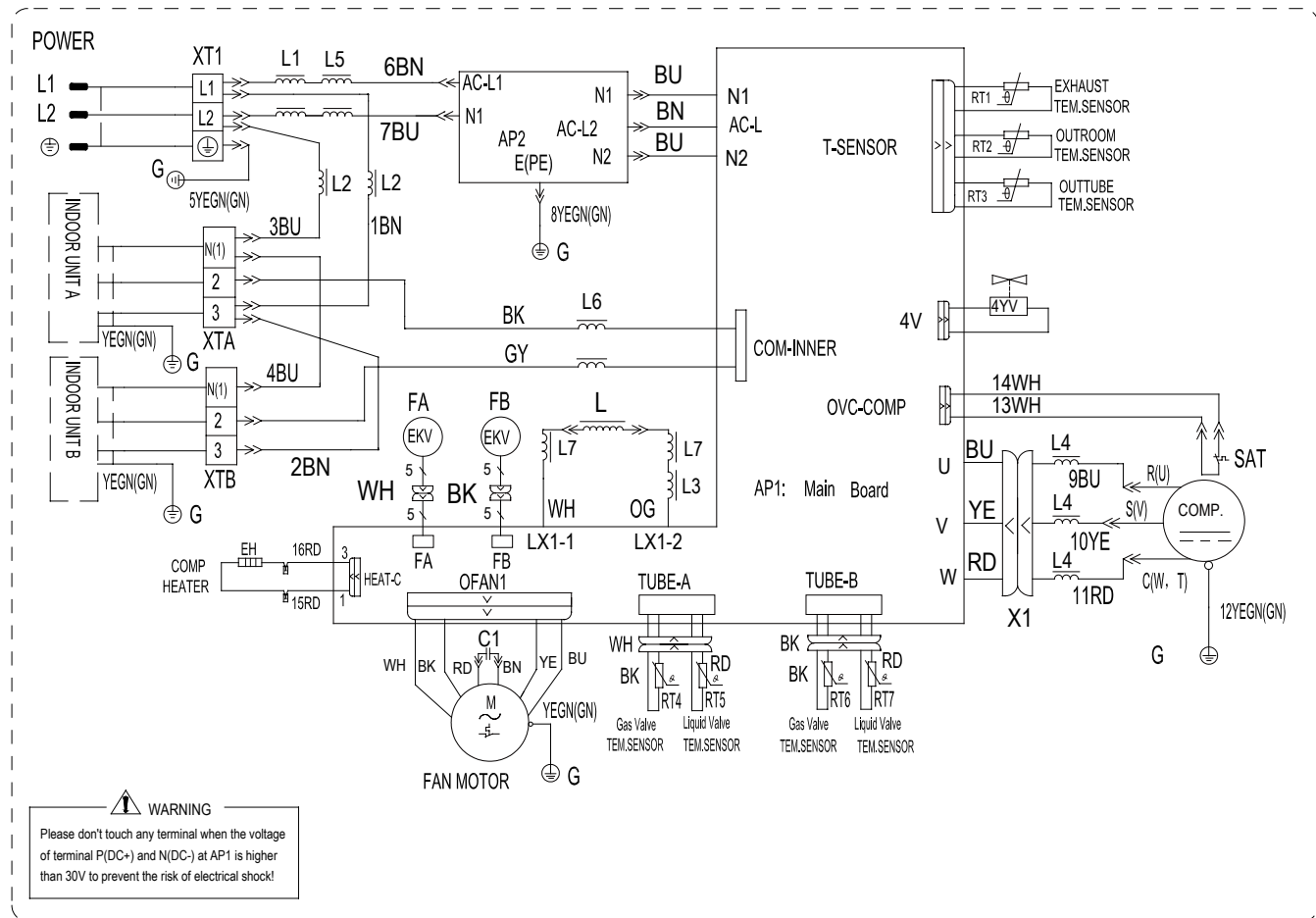

Wiring Diagram 24K

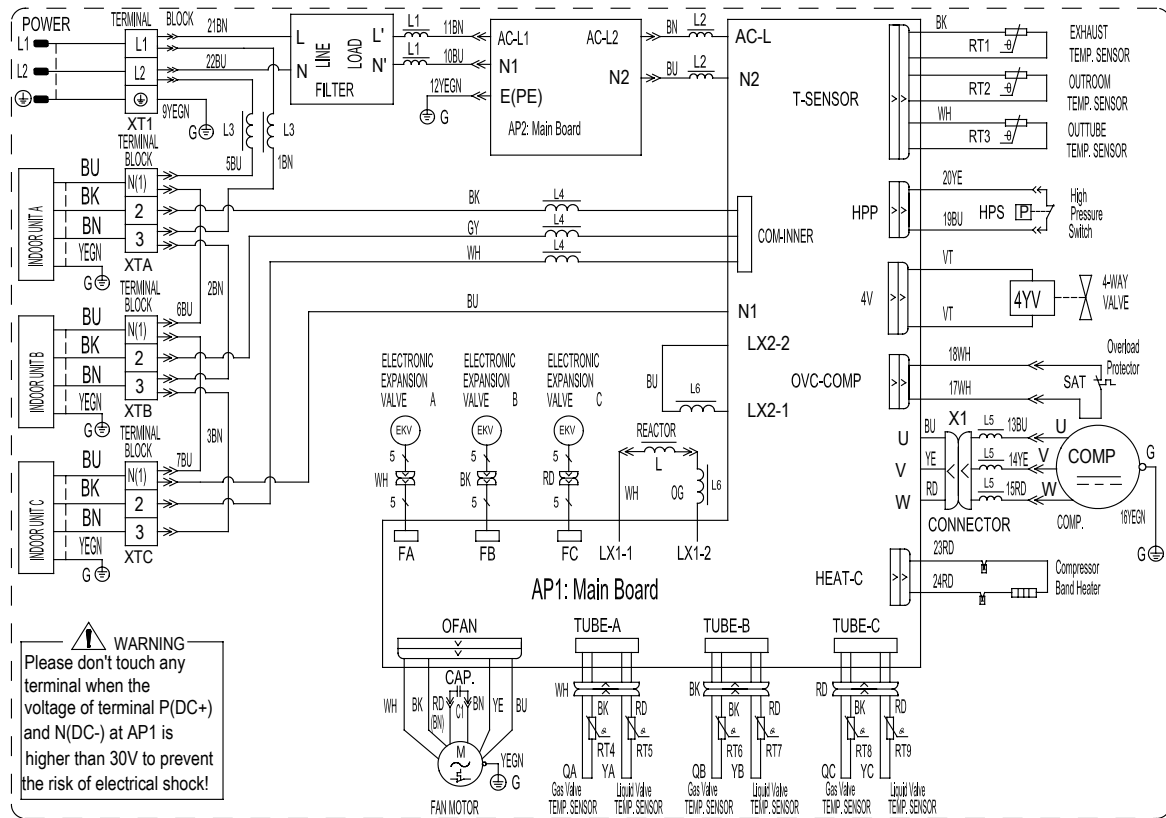

Wiring Diagram 30K

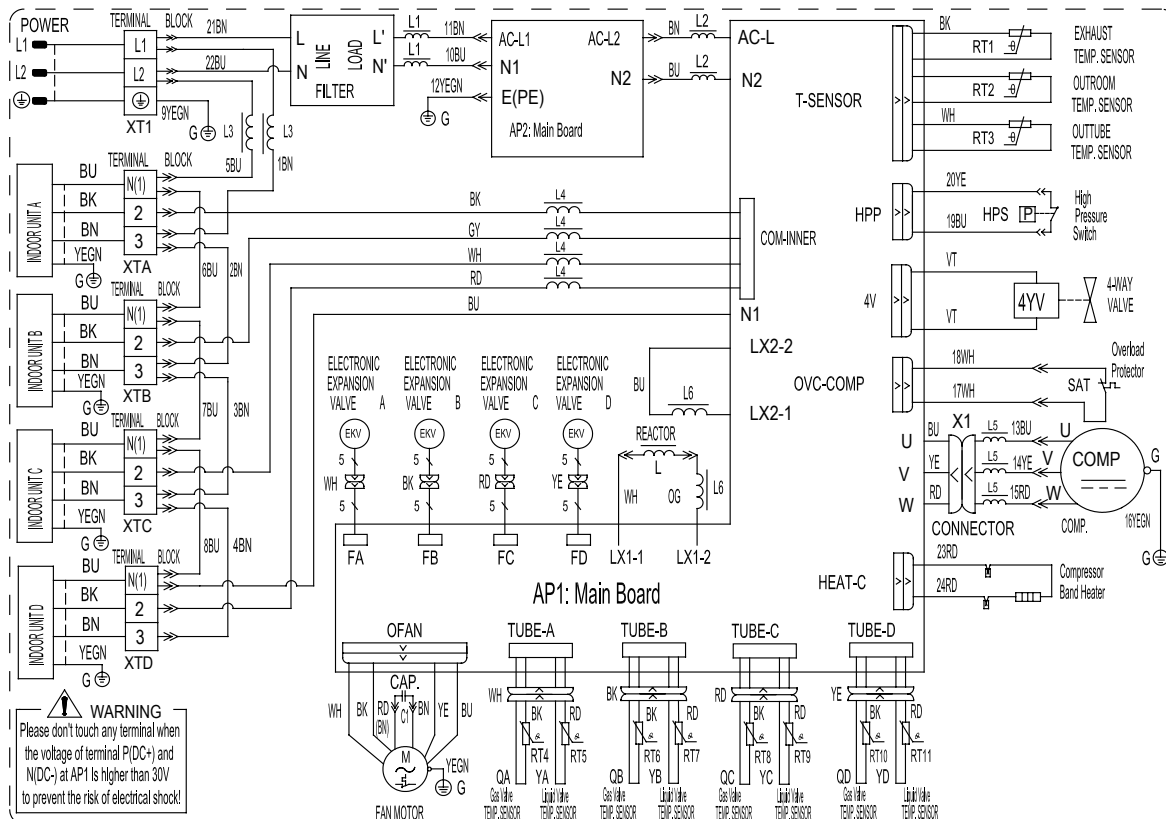

Wiring Diagram 36K

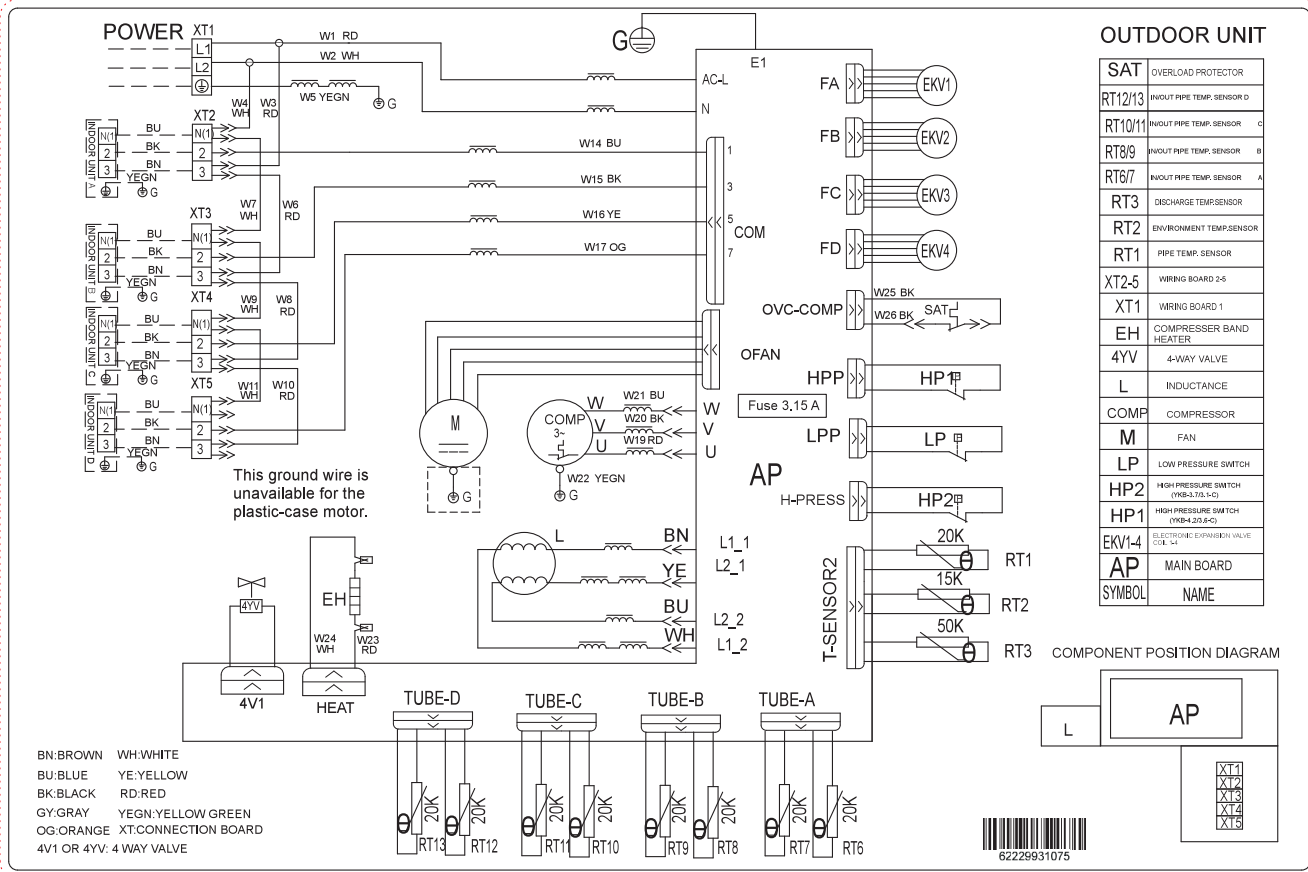

Wiring Diagram 42K

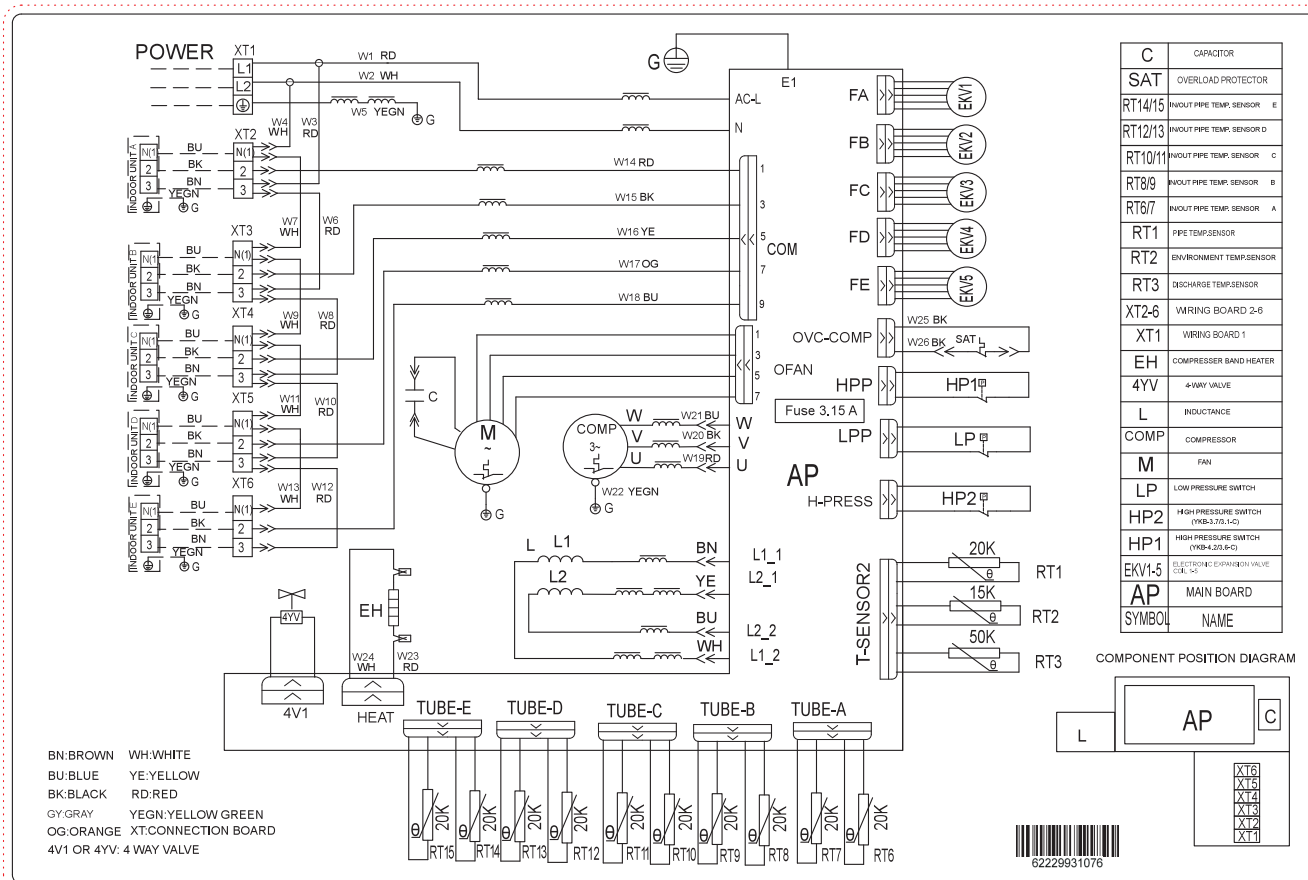

Dimensional Diagrams

18K Units

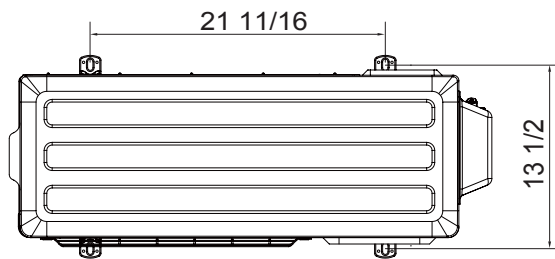
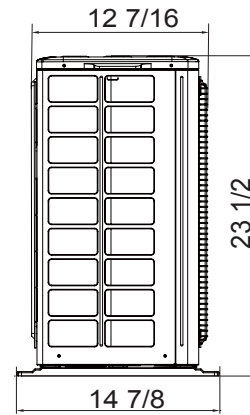
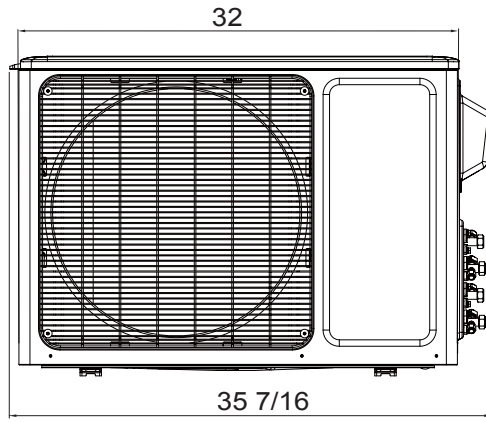

The dimensions in these drawings are rounded according to standard measurement.

Unit:inch

24K-30K Units

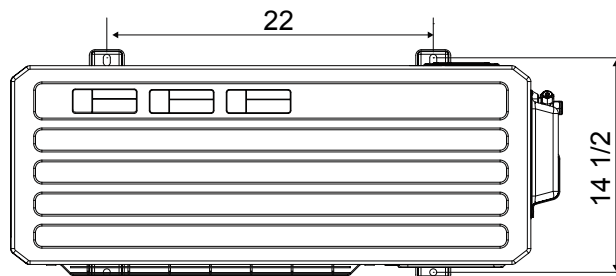
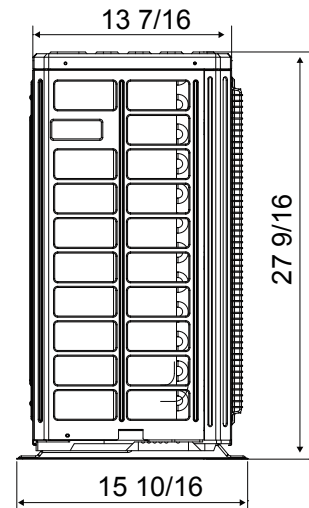
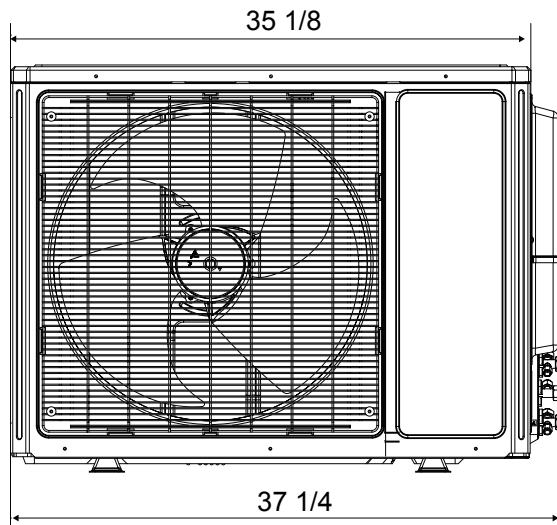

The dimensions in these drawings are rounded according to standard measurement.

Unit:inch

Dimensional Diagrams

36K Units

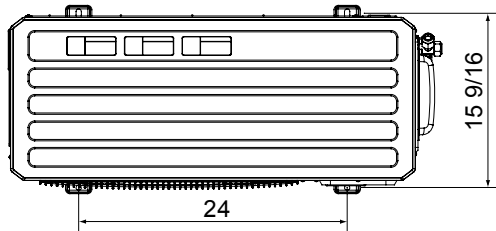
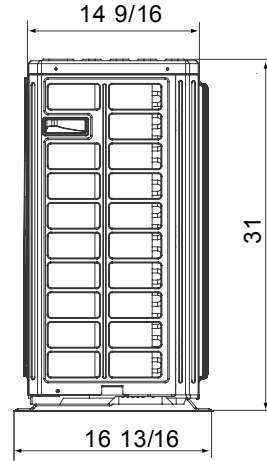
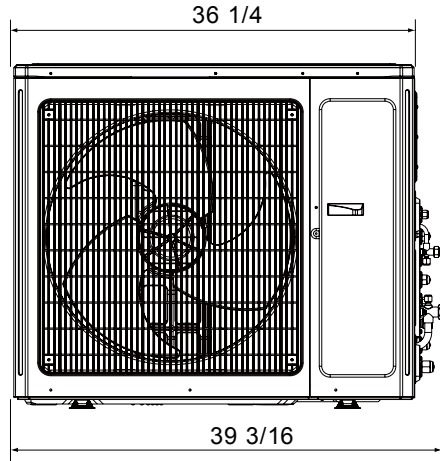

The dimensions in these drawings are rounded according to standard measurement.

Unit:inch

42K Units

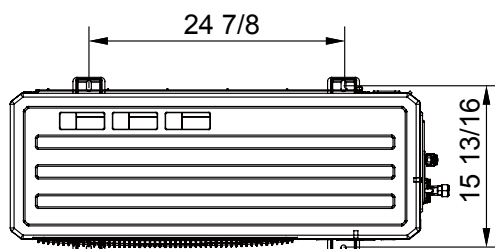
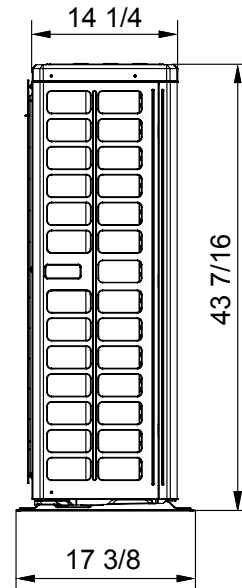
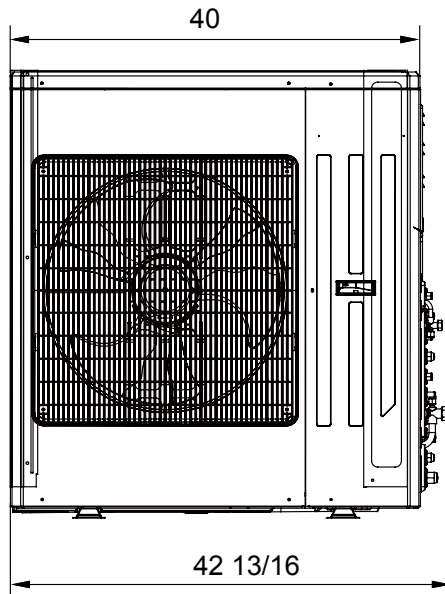

The dimensions in these drawings are rounded according to standard measurement.

Unit:inch

Troubleshooting



WARNING

Improper operation may lead to personal injury or casualty.

- Turn off the main power switch immediately if a malfunction is detected. Contact the installing dealer or qualified service technician. If the unit continues to run during a malfunction, the unit may be damaged or electric shock or fire may occur.
- Do not try to move or reposition the units. Please contact the servicing/installing dealer to repair or move the units.
- Check the following items before contacting the dealer or qualified service technician.

Condition		Possible Reason
Unit doesn't run	When unit is started immediately after it is just turned off	Overload protection switch delays unit start up for three minutes
	When power is turned on	The unit is in standby for one minute
Mist comes from the unit	When cooling cycle starts	Indoor high humidity air is cooled rapidly
Sound comes from the unit	Slight cracking sound is heard when unit starts	This sound occurs when the electronic expansion valve initializes.
	There is sound when cooling	The sound of gas refrigerant flowing in unit
	There is sound when unit starts or stops	This sound occurs when gas refrigerant starts or stops flowing.
	There is slight sound when unit is running or after running	The sound of the drainage system operating.
	Cracking sound is heard when unit is operating and after operating	This sound occurs when the unit panels expand or contract due to temperature change.
The unit blows out dust	When the unit has been off for a period of time.	Dust in indoor unit is blown out
The unit emits odor	When the unit is operating	The room odor absorbed by the unit is blown out again
Indoor unit still runs after switch off	After every indoor unit receives the "stop" signal, fan will keep running	Indoor fan motor will keep running 20-70 seconds to use excess cooling and heating and prepare for the next operation
Mode conflict	COOL or HEAT mode can not be operated	When the indoor operating mode conflicts with that of the outdoor unit, the indoor fault indicator will flash and conflict will be shown on the wired controller after 5 minutes. Indoor unit stops running and the outdoor unit changes its mode of operation to match the indoor unit, then the unit will go back to normal. COOL mode doesn't conflict with DRY mode. FAN mode doesn't conflict with any mode.

NOTE: If the problem persists after checking the above items and taking appropriate measures, please stop operation of the unit immediately and contact your local service agency or dealer. Diagnostics and repairs should be completed by a professional service technician.

Error Codes

The error code will be displayed on the wired controller and the main board of the outdoor unit. The meaning of each error is as shown in the table below.

Error/Malfunction	The Indicator Display			Indoor Display
	Yellow Light	Red Light	Green Light	
Compressor runs	Flash once			
Defrost	Flash twice			H1
Anti-freeze protection	Flash 3 times			E2
IPM protection	Flash 4 times			H5
AC over-current protection	Flash 5 times			E5
Over-burden protection	Flash 6 times			E8
Compressor exhaust high temperature protection	Flash 7 times			E4
Compressor overload protection	Flash 8 times			E4
Power protection	Flash 9 times			L9
EEPROM reads and write protection	Flash 11 times			
Low PN voltage protection	Flash 12 times			PL
Over-voltage protection for PN	Flash 13 times			PH
PFC Protection	Flash 14 times			HC
PFC module temperature protection	Flash 15 times			oE
Low pressure protection	Flash 17 times			E3
High pressure protection	Flash 18 times			E1
Limit/decline frequency (electric current)		Flash 1 time		
Frequency limit (exhaust)		Flash 2 times		
Frequency limit (over-burden)		Flash 3 times		
Outdoor ambient sensor malfunction		Flash 6 times		F3
Outdoor tube sensor malfunction		Flash 5 times		F4
Exhaust sensor malfunction		Flash 7 times		F5
Attain the temperature of switch on		Flash 8 times		
Frequency limit (power)		Flash 13 times		
Outdoor fan malfunction		Flash 14 times		
Frequency limit (PFC module temperature)		Flash 15 times		
PFC module sensor malfunction		Flash 16 times		oE
Liquid pipe temperature sensor malfunction of A		Flash 17 times		
Gas pipe temperature sensor malfunction of A		Flash 18 times		
Liquid pipe temperature sensor malfunction of B		Flash 19 times		
Gas pipe temperature sensor malfunction of B		Flash 20 times		

Name of malfunction	The indicator Display			Indoor Display
	Yellow light	Red light	Green light	
Liquid pipe temperature sensor malfunction of C		Flash 21 times		
Gas pipe temperature sensor malfunction of C		Flash 22 times		
Liquid pipe temperature sensor malfunction of D		Flash 23 times		
Gas pipe temperature sensor malfunction of D		Flash 24 times		
Liquid pipe temperature sensor malfunction of E		Flash 25 times		
Gas pipe temperature sensor malfunction of E		Flash 26 times		
Exit of the condenser tube sensor malfunction		Flash 27 times		
Communication is normal			Flash 7 times (=Indoor unit number)	
Communication failure between indoor unit and outdoor unit			Often bright (indoor unit all communication failure)	
Indoor ambient sensor malfunction				F1
Indoor evaporate sensor malfunction				F2
Mode conflict				E7
Refrigerant recovery mode				Fo
Jumper cap malfunction protection				C5

General Maintenance

Regular checks, maintenance and care should be performed by professional personnel, which will prolong the unit life span.

Outdoor Heat Exchanger

The outdoor heat exchanger should be checked and cleaned once every two months. Use a vacuum cleaner with a nylon brush to clean up dust and debris on the surface of the heat exchanger. Blow away dust by compressed air if available. Never use water to wash the heat exchanger.

Drain Pipe

Regularly check to see if the drain pipe is clogged in order to ensure drain condensate doesn't overflow and cause water damage.

Check Before Seasonal Use

1. The inlet and outlet of the indoor and outdoor units are not clogged or obstructed.
2. The power and communication cables are securely attached and that there is no visible damage to any of the electrical wiring.
3. The batteries of the wireless remote controller have been replaced.
4. The filter screen has been cleaned and replaced securely.
5. After long periods of shutdown, open the main power switch 8 hours before operating the unit so as to preheat the compressor.
6. The outdoor and indoor units are installed securely.
7. If there is anything abnormal, please contact the installing dealer or qualified service technician.

Maintenance After Seasonal Use

1. Cut off the main power supply of the unit. A power disconnect should be located near the outdoor unit.
2. Clean the indoor unit filters.
3. Clean any dust and debris on the indoor and outdoor units.
4. In the event of rusting, use anti-rust paint to stop spreading of rust.

Parts Replacement

Purchase parts from the installing or servicing center or dealer if necessary.

NOTE: During leakage testing, never mix oxygen, ethyne (acetylene) or other dangerous gases into the refrigeration circuit. Nitrogen should be used for leakage testing.

After-Sales Service

In the event you have problems with the unit or require service, please contact your local installing/servicing dealer.

About Trane and American Standard Heating and Air Conditioning

Trane and American Standard create comfortable, energy efficient indoor environments for residential applications. For more information, please visit www.trane.com or www.americanstandardair.com



The AHRI Certified mark indicates company participation in the AHRI Certification program. For verification of individual certified products, go to ahridirectory.org.

The manufacturer has a policy of continuous data improvement and it reserves the right to change design and specifications without notice. We are committed to using environmentally conscious print practices.

88-M4THM15-1E-EN 17 Jun 2020

Supersedes 88-M4THM15-1D-EN (November 2019)

© 2020