

Installation, Operation, and Maintenance

Single Packaged Cooling/Electric Heat Entry, Convertible, 2-5 Ton, R-454B

A5PA3024A1000A
A5PA3030A1000A
A5PA3036A1000A
A5PA3042A1000A
A5PA3048A1000A
A5PA3060A1000A

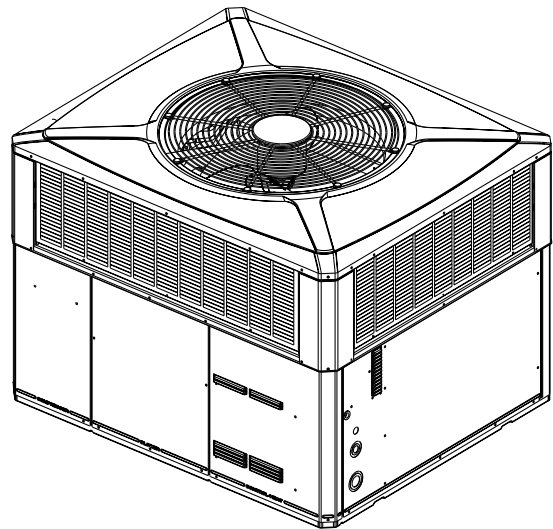

Note: "Graphics in this document are for representation only. Actual model may differ in appearance."

Note: "Unit specific Service Facts available online."

▲ SAFETY WARNING

Only qualified personnel should install and service the equipment. The installation, starting up, and servicing of heating, ventilating, and air-conditioning equipment can be hazardous and requires specific knowledge and training. Improperly installed, adjusted or altered equipment by an unqualified person could result in death or serious injury. When working on the equipment, observe all precautions in the literature and on the tags, stickers, and labels that are attached to the equipment.

SAFETY SECTION

Important: This document contains a wiring diagram, a parts list, and service information. This is customer property and is to remain with this unit. Please return to service information pack upon completion of work.

⚠ WARNING

HAZARDOUS VOLTAGE!

Failure to follow this Warning could result in property damage, severe personal injury, or death.

Disconnect all electric power, including remote disconnects before servicing. Follow proper lockout/tagout procedures to ensure the power cannot be inadvertently energized.

⚠ WARNING

SAFETY AND ELECTRICAL HAZARD!

Failure to follow this Warning could result in property damage, severe personal injury, or death.

These servicing instructions are for use by qualified personnel only. To reduce the risk of electrical shock, do not perform any servicing other than that contained in these operating instructions unless you are qualified to do so.

⚠ CAUTION

GROUNDING REQUIRED!

Failure to inspect or use proper service tools may result in equipment damage or personal injury.

Reconnect all grounding devices. All parts of this product that are capable of conducting electrical current are grounded. If grounding wires, screws, straps, clips, nuts, or washers used to complete a path to ground are removed for service, they must be returned to their original position and properly fastened.

⚠ CAUTION

SHARP EDGE HAZARD!

Failure to follow this Caution could result in property damage or personal injury.

Be careful of sharp edges on equipment or any cuts made on sheet metal while installing or servicing.

⚠ WARNING

UNIT CONTAINS R-454B REFRIGERANT!

Proper service equipment is required. Failure to use proper service tools may result in equipment damage or personal injury.

⚠ WARNING

SERVICE!

USE ONLY R-454B REFRIGERANT AND APPROVED COMPRESSOR OIL.

⚠ WARNING

LEAK DETECTION SYSTEM!

LEAK DETECTION SYSTEM installed. Unit must be powered except for service.

⚠ WARNING

SAFETY HAZARD!

Children should be supervised to ensure that they do not play with the appliance.

⚠ WARNING

SAFETY HAZARD!

This appliance is not to be used by persons (including children) with reduced physical, sensory, or mental capabilities, or lack of experience and knowledge, unless they have been given supervision or instruction concerning the use of the appliance by a person responsible for their safety.

⚠ WARNING

SAFETY HAZARD!

Operating the unit without the access panels properly installed may result in severe personal injury or death.

Do not operate the unit without the evaporator fan access panel or evaporator coil access panel in place.

⚠ WARNING

RISK OF FIRE!

Flammable refrigerant used. To be repaired only by trained service personnel. Do not puncture refrigerant tubing.

Dispose of refrigerant in accordance with federal and/or local regulations.

⚠ WARNING

WARNING!

This product can expose you to chemicals including lead, which are known to the State of California to cause cancer and birth defects or other reproductive harm. For more information go to www.P65Warnings.ca.gov.

Important: Wear appropriate gloves, arm sleeve protectors and eye protection when servicing or maintaining this equipment.

Important: Air filters and media wheels or plates shall meet the test requirements in UL 900.

Table of Contents

Information on Servicing	5	Rooftop Installation — No Curb/ Frame	17
Prior to Beginning Work	5	Ductwork Installation	20
Repairs to Electrical Components	5	Attaching Downflow Ductwork to Roof Curb	20
Detection of Flammable Refrigerants	5	Attaching Downflow Ductwork to Roof Frame	20
Removal and Evacuation	6	Condensate Drain Piping	20
Charging Procedures	6	Air Filter Installation	20
Recovery	6	Electrical Wiring	21
Decommissioning	7	Unit Startup	24
Introduction, Unit Inspection and Specification	8	Pre-Start Quick Checklist	24
Introduction	8	Starting the Unit in Cooling Mode	24
Inspect Shipment	8	Starting the Unit in Heating Mode	24
Product Specification	9	Sequence of Operation	25
Charging in Cooling above 55°F OD Ambient	10	Final Installation Checklist	26
Determine Unit Clearances	11	Verification of Mitigation Actions	26
Review Location and Recommendation Information	13	Maintenance	27
Refrigerant Leak Detection System	14	Owner Maintenance	27
Unit Installation	15	Service Maintenance	27
Ground Level Installation	15	Pressure Curves	28
Rooftop Installation — Curb Mounting	15	Indoor Fan Performance (230v)	34
Lifting and Rigging	16	Refrigerant Circuits	36
Rooftop Installation — Frame Mounting	17	Troubleshooting Chart	37
		Important Product Information	40

Information on Servicing

All replacement parts shall be in accordance with the manufacturer's specifications.

Prior to Beginning Work

Prior to beginning work on systems containing flammable refrigerants, safety checks are necessary to ensure that the risk of ignition is minimized. For repair to the refrigerating system, the following shall be completed prior to conducting work on the system:

- Work shall be undertaken under a controlled procedure to minimize the risk of a flammable gas or vapor being present while the work is being performed.
- All maintenance staff and others working in the local area shall be instructed on the nature of work being carried out. Work in confined spaces shall be avoided.
- The area shall be checked with an appropriate refrigerant detector prior to and during work, to ensure the technician is aware of potentially toxic or flammable atmospheres. Ensure that the leak detection equipment being used is suitable for use with all applicable refrigerants, i.e., non-sparking, adequately sealed or intrinsically safe.
- If any hot work is to be conducted on the refrigerating equipment or any associated parts, appropriate fire extinguishing equipment shall be available to hand. Have a dry powder or CO₂ fire extinguisher adjacent to the charging area.
- No person carrying out work in relation to a refrigerating system which involves exposing any pipe work shall use any sources of ignition in such a manner that it may lead to the risk of fire or explosion. All possible ignition sources, including cigarette smoking, should be kept sufficiently far away from the site of installation, repairing, removing and disposal, during which refrigerant can possibly be released to the surrounding space. Prior to work taking place, the area around the equipment is to be surveyed to make sure that there are no flammable hazards or ignition risks. "No Smoking" signs shall be displayed.
- Ensure that the area is in the open or that it is adequately ventilated before breaking into the system or conducting any hot work. A degree of ventilation shall continue during the period that the work is carried out. The ventilation should safely disperse any released refrigerant and preferably expel it externally into the atmosphere.
- The following checks shall be applied to installations using flammable refrigerants:
 - Marking to the equipment continues to be visible and legible. Markings and signs that are illegible shall be corrected;

- Refrigerating pipe or components are installed in a position where they are unlikely to be exposed to any substance which may corrode refrigerant containing components, unless the components are constructed of materials which are inherently resistant to being corroded or are suitably protected against being so corroded.

Repairs to Electrical Components

Where electrical components are being changed, they shall be fit for the purpose and to the correct specification. At all times the manufacturer's maintenance and service guidelines shall be followed. If in doubt, consult the manufacturer's technical department for assistance.

Repair and maintenance to electrical components shall include initial safety checks and component inspection procedures. If a fault exists that could compromise safety, then no electrical supply shall be connected to the circuit until it is satisfactorily dealt with. If the fault cannot be corrected immediately but it is necessary to continue operation, an adequate temporary solution shall be used. This shall be reported to the owner of the equipment, so all parties are advised.

Initial safety checks shall include:

- That capacitors are discharged; this shall be done in a safe manner to avoid possibility of sparking;
- That no live electrical components and wiring are exposed while charging, recovering or purging the system;
- That there is continuity of earth bonding.

Check that cabling will not be subject to wear, corrosion, excessive pressure, vibration, sharp edges or any other adverse environmental effects. The check shall also take into account the effects of aging or continual vibration from sources such as compressors or fans.

Detection of Flammable Refrigerants

Under no circumstances shall potential sources of ignition be used in the searching for or detection of refrigerant leaks. A halide torch (or any other detector using a naked flame) shall not be used.

The following leak detection method is deemed acceptable for all refrigerant systems:

- Electronic leak detectors may be used to detect refrigerant leaks but, in the case of flammable refrigerants, the sensitivity may not be adequate, or may need re-calibration. (Detection equipment shall

be calibrated in a refrigerant-free area.) Ensure that the detector is not a potential source of ignition and is suitable for the refrigerant used. Leak detection equipment shall be set at a percentage of the LFL of the refrigerant and shall be calibrated to the refrigerant employed, and the appropriate percentage of gas (25 % maximum) is confirmed.

- Leak detection fluids are also suitable for use with most refrigerants but the use of detergents containing chlorine shall be avoided as the chlorine may react with the refrigerant and corrode the copper pipe-work.

Example of leak detection fluids are:

- Bubble method,
- Fluorescent method agents

If a leak is suspected, all naked flames shall be removed/extinguished.

If a leakage of refrigerant is found which requires brazing, all of the refrigerant shall be recovered from the system, or isolated (by means of shut off valves) in a part of the system remote from the leak.

Removal and Evacuation

When breaking into the refrigerant circuit to make repairs - or for any other purpose - conventional procedures shall be used. However, for flammable refrigerants it is important that best practice be followed, since flammability is a consideration. The following procedure shall be adhered to:

- Safely remove refrigerant following local and national regulations;
- Evacuate;
- Purge the circuit with inert gas;
- Evacuate;
- Continuously flush or purge with inert gas when using flame to open circuit;
- And open the circuit.

The refrigerant charge shall be recovered into the correct recovery cylinders if venting is not allowed by local and national codes. For appliances containing flammable refrigerants, the system shall be purged with oxygen-free nitrogen to render the appliance safe for flammable refrigerants.

This process might need to be repeated several times. Compressed air or oxygen shall not be used for purging refrigerant systems.

For appliances containing flammable refrigerants, refrigerants purging shall be achieved by breaking the vacuum in the system with oxygen-free nitrogen and continuing to fill until the working pressure is achieved, then venting to atmosphere, and finally pulling down to a vacuum. This process shall be repeated until no refrigerant is within the system. When the final oxygen-free nitrogen charge is used, the system shall be

vented down to atmospheric pressure to enable work to take place.

The outlet for the vacuum pump shall not be close to any potential ignition sources, and ventilation shall be available.

Charging Procedures

In addition to conventional charging procedures, the following requirements shall be followed.

- Ensure that contamination of different refrigerants does not occur when using charging equipment. Hoses or lines shall be as short as possible to minimise the amount of refrigerant contained in them.
- Cylinders shall be kept in an appropriate position according to the instructions.
- Ensure that the refrigerating system is earthed prior to charging the system with refrigerant.
- Label the system when charging is complete (if not already).
- Extreme care shall be taken not to overfill the refrigerating system.

Prior to recharging the system, it shall be pressure-tested with the appropriate purging gas. The system shall be leak-tested on completion of charging but prior to commissioning. A follow up leak test shall be carried out prior to leaving the site.

Important: *The unit should not be tested higher than 450 psig for servicing or component replacement.*

See installation instructions below for further details.

Recovery

When removing refrigerant from a system, either for servicing or decommissioning, it is recommended good practice that all refrigerants are removed safely.

When transferring refrigerant into cylinders, ensure that only appropriate refrigerant recovery cylinders are employed. Ensure that the correct number of cylinders for holding the total system charge is available. All cylinders to be used are designated for the recovered refrigerant and labelled for that refrigerant (i.e., special cylinders for the recovery of refrigerant). Cylinders shall be complete with pressure-relief valve and associated shut-off valves in good working order. Empty recovery cylinders are evacuated and, if possible, cooled before recovery occurs.

The recovery equipment shall be in good working order with a set of instructions concerning the equipment that is at hand and shall be suitable for the recovery of the flammable refrigerant. If in doubt, the manufacturer should be consulted. In addition, a set of calibrated weighing scales shall be available and in

good working order. Hoses shall be complete with leak-free disconnect couplings and in good condition.

The recovered refrigerant shall be processed according to local legislation in the correct recovery cylinder, and the relevant waste transfer note arranged. Do not mix refrigerants in recovery units and especially not in cylinders.

If compressors or compressor oils are to be removed, ensure that they have been evacuated to an acceptable level to make certain that flammable refrigerant does not remain within the lubricant. The compressor body shall not be heated by an open flame or other ignition sources to accelerate this process. When oil is drained from a system, it shall be carried out safely.

Decommissioning

Before carrying out this procedure, it is essential that the technician is completely familiar with the equipment and all its detail. It is recommended good practice that all refrigerants are recovered safely. Prior to the task being carried out, an oil and refrigerant sample shall be taken in case analysis is required prior to re-use of recovered refrigerant. It is essential that electrical power is available before the task is commenced.

1. Become familiar with the equipment and its operation.
2. Isolate system electrically.
3. Before attempting the procedure, ensure that:
 - a. Mechanical handling equipment is available, if required, for handling refrigerant cylinders;
 - b. All personal protective equipment is available
- and being used correctly;
- c. The recovery process is supervised at all times by a competent person;
- d. Recovery equipment and cylinders conform to the appropriate standards.
4. Pump down refrigerant system, if possible.
5. If a vacuum is not possible, make a manifold so that refrigerant can be removed from various parts of the system.
6. Make sure that cylinder is situated on the scales before recovery takes place.
7. Start the recovery machine and operate in accordance with instructions.
8. Do not overfill cylinders (no more than 80 % volume liquid charge).
9. Do not exceed the maximum working pressure of the cylinder, even temporarily.
10. When the cylinders have been filled correctly and the process completed, make sure that the cylinders and the equipment are removed from site promptly and all isolation valves on the equipment are closed off.
11. Recovered refrigerant shall not be charged into another refrigerating system unless it has been cleaned and checked.

Equipment shall be labelled stating that it has been decommissioned and emptied of refrigerant. The label shall be dated and signed. For appliances containing flammable refrigerant, ensure that there are labels on the equipment stating the equipment contains flammable refrigerant.

Introduction, Unit Inspection and Specification

Introduction

Read this manual carefully before attempting to install, operate, or perform maintenance on this unit. Installation and maintenance should be performed by qualified service technicians only. This unit is listed by Underwriters Laboratory.

Packaged units are designed for outdoor mounting with a vertical condenser discharge. They can be located either at ground level or on a roof in accordance with local codes. Each unit contains an operating charge of refrigerant as shipped.

Extreme mounting kits are available for slab (BAYEXMK003), utility curb (BAYEXMK002) and perimeter curb (BAYEXMK001) mountings.

Inspect Shipment

1. Check for damage after the unit is unloaded. Report promptly to the carrier any damage found to the unit. Do not drop the unit.

Important: To prevent damage to the sides and top of the unit when hoisting, use "spreader bars" see, "Rooftop Installation — No Curb/Frame," p. 17.

2. Check the unit's nameplate to determine if the unit is correct for the intended application. The power supply must be adequate for both the unit and all accessories.
3. Check to be sure the refrigerant charge has been retained during shipment. Remove the Compressor access panel to access the 1/4" flare pressure taps.
4. If this unit is being installed on a curb, verify that the correct curb is provided with the unit.
 - A5PA3024-036 use model BAYCURB050,
 - A5PA3042-060 use model BAYCURB051
5. If the unit is being hoisted, accessory kit BAYLIFT002 is recommended. It includes a kit of four (4) lifting lugs and instructions.

Notes:

- *If practical, install any internal accessories to the unit at the shop.*
- *The packaged units have been evaluated in accordance with the Code of Federal Regulations, Chapter XX, Part 3280 or the equivalent. "SUITABLE FOR MOBILE HOME USE."*

Product Specification

MODEL	A5PA3024	A5PA3030	A5PA3036	A5PA3042	A5PA3048	A5PA3060
RATED Volts/Ph/Hz	208-230/1/60					
Performance Cooling BTUH ^(a)	24000	28400	36800	40000	47500	58500
Indoor Airflow (CFM)	820	920	1190	1500	1670	1700
Power Input (KW)	LOCATED ON UNIT NAMEPLATE					
EER2/SEER2 (BTU/Watt-Hr.) ^(b)	10.6/13.4					
Sound Power Rating [dB(A)] ^(c)	66.6	70	69.3	74.6	72.5	73.1
POWER CONN. – V/Ph/Hz	208-230/1/60					
Min. Brch. Cir. Ampacity ^(d)	LOCATED ON UNIT NAMEPLATE					
Fuse Size – Max. (amps)	25	30	40	40	50	60
Fuse Size – Recmd. (amps)	25	30	40	40	50	60
COMPRESSOR	SCROLL					
Volts/Ph/Hz	208-230/1/60					
R.L. Amps – L.R. Amps	LOCATED ON UNIT NAMEPLATE					
OUTDOOR COIL – TYPE	SPINE-FIN					
Rows/F.P.I	2 / 24					
Face Area (sq. ft.)	13.32	13.32	15.49	15.63	20.54	22.99
Tube Size (in.)	3/8					
INDOOR COIL – TYPE	MCHE					RTPF
Rows/F.P.I	2 / 16					4 / 15
Face Area (sq. ft.)	2.7			3.9	3.9	5.0
Tube Size (in.)	0.81	0.81	1.00	0.81	0.81	0.38
Refrigeration Control	EXPANSION VALVE					
Drain Conn. Size (in.)	3/4 FEMALE NPT					
OUTDOOR FAN – TYPE	PROPELLER					
DIA. (IN.)	23.4			28.3		
DRIVE/NO. SPEEDS	DIRECT / 1					
CFM @ 0.0 in. w.g ^(e)	2350	2800	3080	3400	3400	4800
Motor – HP/R.P.M	1/12 / 825	1/6 / 825	1/5 / 825	1/4 / 825	1/4 / 825	1/3 / 825
Volts/Ph/Hz	208-230/1/60					
F.L. Amps/L.R Amps	LOCATED ON UNIT NAMEPLATE					
INDOOR FAN – TYPE	CONSTANT TORQUE ECM					
Dia. x Width (in.)	10.62 X 10.62					11.87 X 10.62
Drive/No. Speeds	DIRECT / 4					
CFM @ 0.0 in. w.g ^(f)	SEE FAN PERFORMANCE TABLE					
Motor – HP / R.P.M.	1/3 / 1050	1/2 / 1050	3/4 / 1050			1 / 1050
Volts/Ph/Hz	208-230/1/60					
F.L. Amps	LOCATED ON UNIT NAMEPLATE					
FILTER / FURNISHED	NO					
Type Recommended	THROWAWAY					
Recmd. Face Area (sq. ft) ^(g)	4			5.3		
REFRIGERANT	R-454B					
Charge (lbs.)	LOCATED ON UNIT NAMEPLATE					
CHARGING SPECIFICATIONS						
Subcooling	12° F	10° F	12° F	12° F	10° F	13° F

(a) Rated in accordance with AHRI Standard 210/240.

(b) Rated in accordance with D.O.E. test procedure.

(c) Sound Power values are not adjusted for AHRI 270-95 tonal corrections.

(d) Calculated in accordance with currently prevailing Nat'l Electrical Code.

(e) Standard Air – Dry Coil – Outdoor.

(f) Standard Air – Dry Coil – Indoor

(g) Filters must be installed in return air stream. Square footages listed are based on 300 f.p.m. face velocity. If permanent filters are used size per manufacturer's recommendation with a clean resistance of 0.05" W.C.

Charging in Cooling above 55°F OD Ambient

If servicing the equipment requires system evacuation, then re-charge the system to the weight specified on the nameplate. Verify the system subcooling using the Subcooling Charging Table and, if necessary, adjust the charge using the procedure below.

1. For best results — the indoor temperature should be kept between 70°F to 80°F. Add system heat if needed.
2. Whenever charge is removed or added, the system must be operated for a minimum of 20 minutes to stabilize before accurate measurements can be made.
3. Measure Liquid Line Temperature and Refrigerant Pressure at service valved in the compressor compartment.
4. Locate your liquid line temperature in the left column of the table, and the intersecting liquid line

pressure under the subcool value column, Add refrigerant to raise the pressure to match the table, or remove refrigerant to lower the pressure. Again, wait 20 minutes for the system conditions to stabilize before adjusting charge again.

Note: System charge shall never be more than 110% or less than 90% of nameplate charge. If specified subcooling cannot be achieved within those charge bounds, contact your Field Service Representative.

5. When system is correctly charged, you can refer to System Pressure Curves to verify typical performance.

CHARGING BELOW 55°F

Evacuate system and weigh in nameplate charge or use factory charge. Correct subcooling may be verified when the temperature is above 55°F.

R-454B REFRIGERANT CHARGING CHART									
LIQUID TEMP (°F)	DESIGN SUBCOOLING (°F)								
	6	7	8	9	10	11	12	13	14
	LIQUID GAGE PRESSURE (PSI)								
55	164	167	170	172	175	178	181	184	187
60	178	181	184	187	190	194	197	200	203
65	193	197	200	203	206	210	213	217	220
70	210	213	217	220	223	227	230	234	238
75	227	230	234	238	241	245	249	252	256
80	245	249	252	256	260	264	268	272	276
85	264	268	272	276	280	284	288	292	297
90	284	288	292	297	301	305	309	314	318
95	305	309	314	318	323	327	332	336	341
100	327	332	336	341	346	351	355	360	356
105	351	355	360	365	370	375	380	385	390
110	375	380	385	390	396	401	406	412	417
115	401	406	412	417	422	428	433	439	445
120	428	433	439	445	450	456	462	468	474
125	456	462	468	474	480	486	492	498	504

Determine Unit Clearances

Figure 1. Space on Sides Requirements

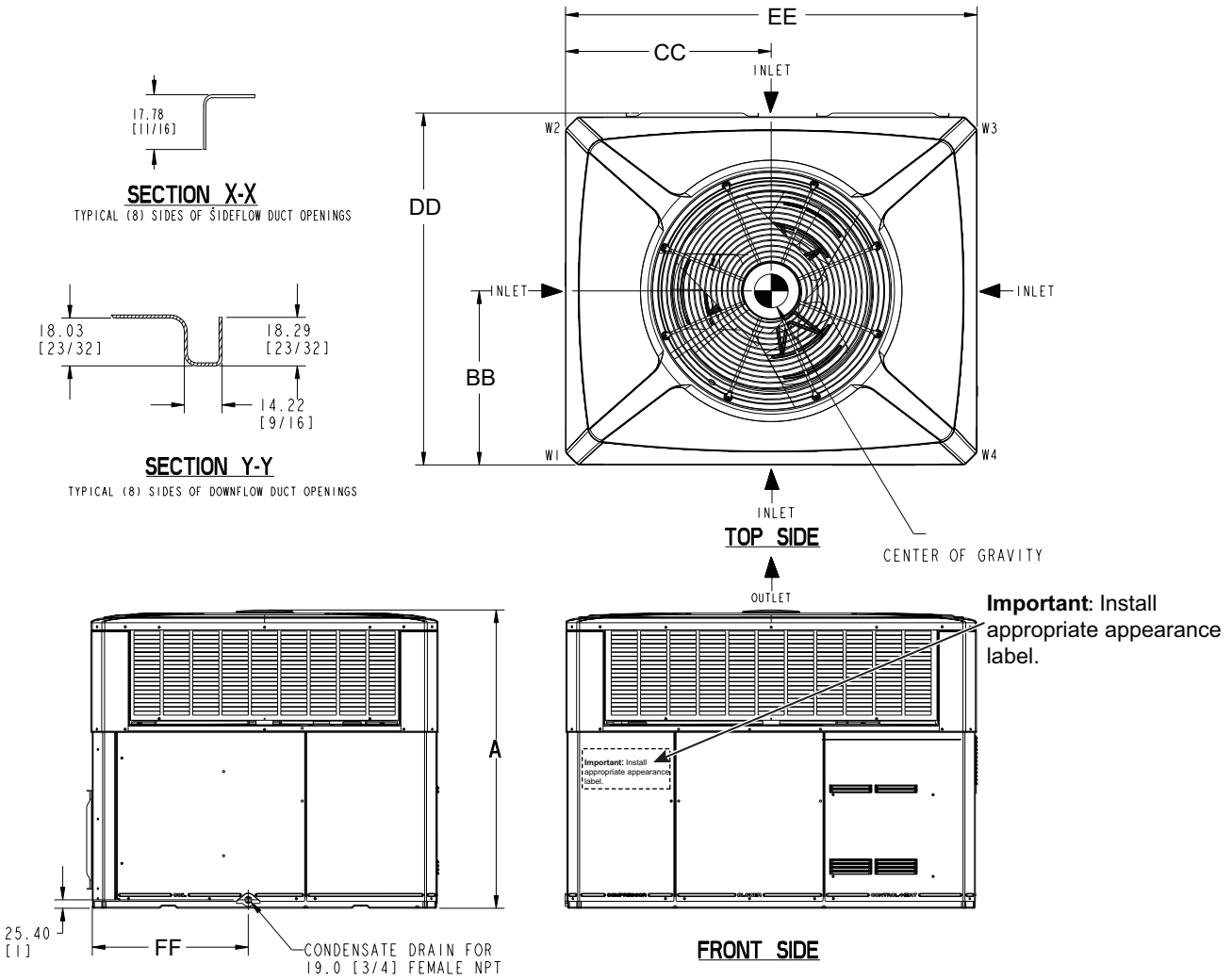

	2 - 3 TON Units		3.5 - 5 TON Units	
	RECOMMENDED SERVICE CLEARANCE mm [Inches]			
	W/ ECONOMIZER		W/ ECONOMIZER	
BACK SIDE	305 [12]	762 [30]	305 [12]	762 [30]
LEFT SIDE	762 [30]	914 [36]	914 [36]	1067 [42]
RIGHT SIDE	610 [24]	-	610 [24]	-
FRONT SIDE	1067 [42]	-	762 [30]	-
	CLEARANCE TO COMBUSTIBLE MATERIAL mm [Inches]			
BOTTOM	0		0	
BACK SIDE	25 [1]		25 [1]	
LEFT SIDE	152 [6]		152 [6]	
RIGHT SIDE	152 [6]		152 [6]	
FRONT SIDE	305 [12]		305 [12]	
TOP	914 [36]		914 [36]	
	DIMENSIONS mm [Inches]			
A	HEIGHT OF UNIT - TABLE NEXT PAGE			
BB	CENTER OF GRAVITY - TABLE NEXT PAGE			
CC	CENTER OF GRAVITY - TABLE NEXT PAGE			
DD -Depth	1049.02 [41-5/16]		1125.22 [44-5/16]	
EE -Width	1240.28 [48-27/32]		1487.17 [58-9/16]	
FF	469.93 [18-1/2]		551.48 [21-23/32]	

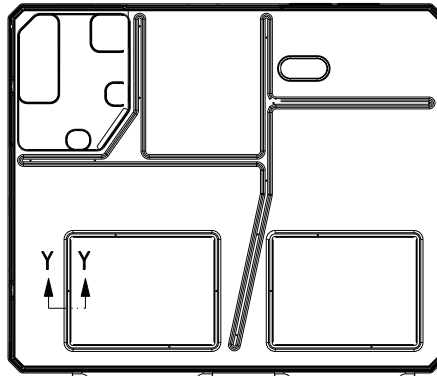

Determine Unit Clearances

Figure 2. Bottom and Back Duct Openings

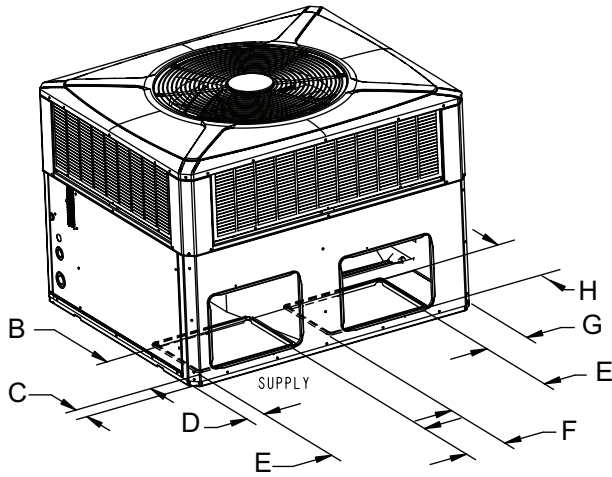

BOTTOM DUCT OPENINGS

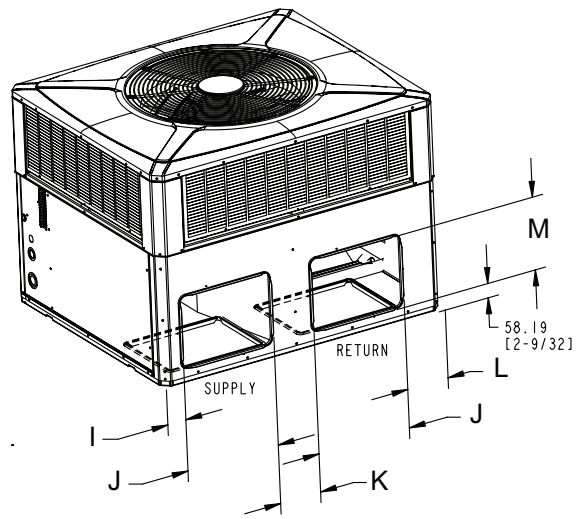

BACK DUCT OPENINGS

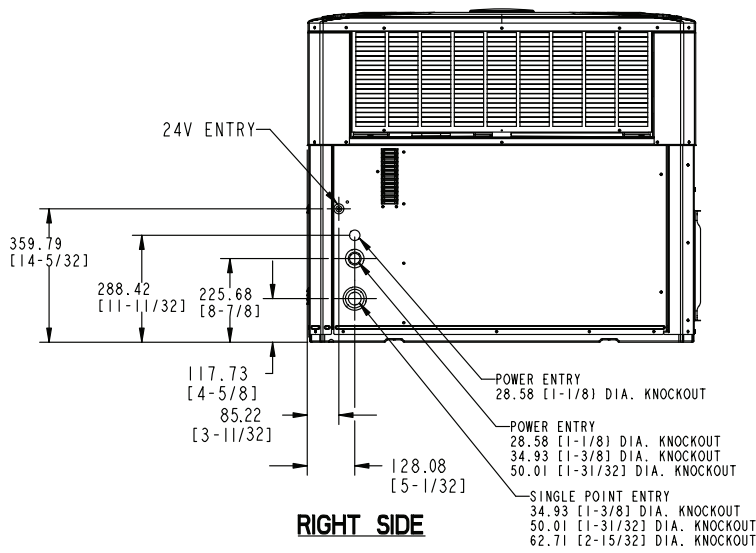

RIGHT SIDE

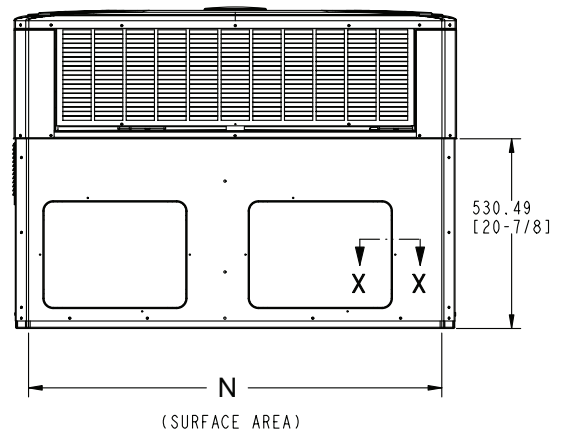

BACK SIDE

	Height mm [in]	PHYSICAL DIMENSIONS mm [in]												
	A-Height	B	C	D	E	F	G	H	I	J	K	L	M	N
A5PA3024	898.53 [35 - 3/8]	304.80 [12.0]	75.41 [2.93]	75.41 [2.93]	406.40 [16.0]	167.89 [6.61]	173.46 [6.8]	304.80 [12.0]	79.50 [3.13]	398.22 [15.68]	176.07 [6.93]	177.55 [6.99]	296.62 [11.68]	1155.45 [45.49]
A5PA3030	949.33 [37 - 3/8]													
A5PA3036														
A5PA3042	898.53 [35 - 3/8]	457.20 [18.0]	75.41 [2.97]	75.41 [2.97]	381.00 [15.0]	244.09 [9.61]	318.75 [12.55]	381.00 [15.0]	79.50 [3.13]	449.02 [17.68]	176.07 [6.93]	322.84 [12.71]	372.82 [14.68]	1402.34 [55.21]
A5PA3048	1000.13 [39 - 3/8]													
A5PA3060														

	Corner Weights KG [LBS]				SHIPPING WEIGHT KG [LBS]	UNIT WEIGHT KG [LBS]	Center Of Gravity mm [inch]	
	W1	W2	W3	W4			BB	CC
A5PA3024	60.3 [133]	36.8 [81]	26.1 [58]	41.0 [90]	197.8 [436]	164.2 [362]	479.8 [18.9]	527.8 [20.8]
A5PA3030	63.1 [139]	38.7 [85]	27.5 [61]	43.1 [95]	205.9 [454]	172.4 [380]	406.5 [16.0]	594.1 [23.4]
A5PA3036	63.9 [141]	38.9 [86]	27.7 [61]	43.7 [96]	207.7 [458]	174.2 [384]	414.3 [16.3]	697.6 [27.5]
A5PA3042	72.7 [160]	47.2 [104]	35.2 [78]	53.6 [118]	255.8 [564]	208.7 [460]	470.8 [18.5]	731.0 [28.8]
A5PA3048	75.0 [165]	45.0 [99]	33.8 [75]	54.4 [120]	255.4 [563]	208.2 [459]	433.0 [17.0]	743.3 [29.3]
A5PA3060	79.3 [175]	46.3 [102]	34.9 [77]	59.0 [130]	266.7 [588]	219.5 [484]	414.0 [16.3]	635.0 [25.0]

Review Location and Recommendation Information

Note: *There is no declared maximum altitude for operating the appliance.*

Horizontal Airflow Units

1. Location of the unit must allow service clearance around it to ensure adequate serviceability, maximum capacity, and peak operating efficiency.
2. These units are designed for outdoor installation. They may be installed directly on a slab, wood flooring, or on Class A, B, or C roof covering material. The discharge air from the condenser fans must be unrestricted for a minimum of 3 feet above the unit.
3. Check the handling facilities to ensure the safety of personnel and the unit(s).
4. The unit must be mounted level for proper drainage of water through the drain holes in the base pan.
5. The unit should not be exposed to direct roof water runoff.
6. Flexible duct connectors must be of a flame retardant material. All duct work outside of the structure must be insulated and weatherproofed in accordance with local codes.
7. Holes through exterior walls or roof must be sealed in accordance with local codes.
8. All fabricated outdoor ducts should be as short as possible.

Clearances

1. The recommended clearances for single-unit installations are illustrated in [“Determine Unit Clearances,” p. 11.](#)
2. Any reduction of the unit clearances indicated in these figures may result in condenser coil starvation or the recirculation of warm condenser air. Actual clearances, which appear to be inadequate should be reviewed with a local engineer.
3. See the unit’s nameplate for the absolute minimum clearance between the unit and any combustible surfaces.

Down Airflow Units

1. Location of the unit must allow service clearance around it to ensure adequate serviceability, maximum capacity, and peak operating efficiency.
2. Refer to the Installation section for instruction on converting the supply and return airflow covers to down airflow.

3. The field assembled Roof Mounting Curb (BAYCURB050 or BAYCURB051) or a field fabricated curb should be in place before the unit is hoisted to the roof top.
The Roof Mounting Curb (frame) must be installed on a flat, level section of the roof (maximum of 1/4" per foot pitch) and provide a level mounting surface for the unit. Also, be sure to provide sufficient height above the roof to prevent water from entering the unit.
4. Be sure the mounting curb spans structural members (trusses) of the roof, thereby providing sufficient support for the weight of the unit, the curb, the duct(s), and any factory or field installed accessories.
5. The unit must be mounted level for proper drainage of water through the drain holes in the base pan.
6. Be sure the hole in the structure for the ducts is large enough to accommodate the fabricated ducts and the insulation surrounding them. Flexible duct connectors must be of a flame retardant material. All duct work outside of the structure must be insulated and weatherproofed in accordance with local codes.
7. Holes through exterior walls or roof must be sealed in accordance with local codes.
8. These units are design certified for outdoor installation. They may be installed directly on a slab, wood flooring, or on Class A, B, or C roof covering material. The discharge air from the condenser fans must be unrestricted for a minimum of 3 feet above the unit.
9. Check the handling facilities to ensure the safety of personnel and the unit(s).

Clearances

1. The recommended clearances for single-unit installations are illustrated in [“Determine Unit Clearances,” p. 11.](#)
2. Any reduction of the unit clearances indicated in these figures may result in condenser coil starvation or the recirculation of warm condenser air. Actual clearances, which appear to be inadequate should be reviewed with a local engineer.
3. See the unit’s nameplate for the absolute minimum clearance between the unit and any combustible surfaces.

Refrigerant Leak Detection System

For all tables contained in this section of the manual, the refrigerant charge is the total system charge which is marked on the unit nameplate.

⚠ WARNING

Risk of Fire!
Flammable refrigerant used. To be repaired only by trained service professional. Do not puncture refrigerant tubing.
Dispose of properly in accordance with federal or local regulations. Flammable refrigerant used.

⚠ WARNING

LEAK DETECTION SYSTEM!
LEAK DETECTION SYSTEM installed. Unit must be powered except for service.

To ensure safety of the building occupants, the packaged unit is equipped with a refrigerant leak detection system. The system is comprised of a refrigerant sensor and a mitigation control board. The system automatically detects leaks in the indoor coil and initiates actions to mitigate the risk of ignition of the leaked refrigerant, including:

- Turning on the blower of the indoor unit to dilute leaked refrigerant;
- Fully opening any zoning dampers, when applicable;
- Turning off the compressor of the outdoor unit;
- De-energizing potential sources of ignition connected to the system;
- Energizing an audible alarm, if so equipped. Examples of potential ignition sources that are de-energized include electrostatic air cleaners.

Minimum Conditioned Space

The installer must verify that the total space conditioned by the system is large enough to safely dilute any leaked refrigerant in the event of a refrigerant leak of the indoor coil.

The minimum space conditioned by the appliance shall be according to [Table 1, p. 14](#). The conditioned space includes any parts of the space connected via an air duct system. The altitude of installation is the altitude above sea level of the site where the equipment is installed.

Table 1. Minimum Space Conditioned by the Appliance

	Altitude (ft)								
	Sea Level — 2,000	2,001 — 4,000	4,001 — 6,000	6,001 — 8,000	8,001 — 10,000	10,001 — 12,000	12,001 — 14,000	14,001 — 15,000	Above 15,000
Charge (lb)	Minimum Conditioned Space (ft ²)								
4	63	66	70	74	79	85	91	94	98
5	79	83	88	93	99	106	113	118	122
6	95	100	105	112	119	127	136	141	147
7	110	116	123	130	138	148	159	165	171
8	126	133	140	149	158	169	181	188	196
9	142	149	158	167	178	190	204	212	220
10	158	166	175	186	198	211	227	235	245
11	173	183	193	205	218	232	249	259	269
12	189	199	211	223	237	254	272	282	294
13	205	216	228	242	257	275	295	306	318
14	221	232	246	260	277	296	318	330	343
15	236	249	263	279	297	317	340	353	367

Unit Installation

Note: The factory ships this unit for horizontal installation.

Ground Level Installation

To Install the unit at ground level:

1. Place the unit on a pad the size of the unit or larger. The unit must be mounted level for proper drainage of water through the holes in the base pan. To attach the unit securely to the slab, use extreme mounting kit, BAYEXMK003. Usage of the extreme mounting kit accessories is a recommendation, not a requirement.

The pad must not come in contact with the structure. Be sure the outdoor portion of the supply and return air ducts are as short as possible. As indicated in Table 4, p. 17, vibration support is a recommendation, not a requirement.

2. Location of the unit must allow service clearance around it. Clearance of the unit must be given careful consideration. See, "Determine Unit Clearances," p. 11.

Note: Any reduction of the unit clearances indicated in these illustrations may result in condenser coil starvation or the recirculation of warm condenser air. Actual clearances, which appear to be inadequate should be reviewed with a local engineer.

Important: A minimum 0" clearance to combustible material shall be maintained on air outlet duct.

3. Attach the supply and return air ducts to the unit as explained in the ductwork Installation section.
4. Flexible duct connectors must be of a flame retardant material. Insulate any ductwork outside of the structure with at least two (2) inches of

insulation and weatherproof. There must be a weatherproof seal where the duct enters the structure.

5. Do not expose the unit to direct roof water runoff.
6. Seal all holes through exterior walls in accordance with local codes.
7. Continue with the following installation sections to complete the installation: Ductwork, Filter and Electrical Wiring.

Rooftop Installation – Curb Mounting

Convert Horizontal Airflow to Down Airflow

The factory ships the unit for horizontal airflow. Perform this procedure to convert it to down airflow:

1. Remove the three (3) sheet metal screws securing the supply air cover and the four (4) sheet metal screws securing the return air cover from the base of the unit. Remove the covers from the base.
2. Place the covers over the horizontal supply and return openings (painted side out). Align the screw holes, and secure using the same screws removed in step 1.

Install Full Perimeter Roof Mounting Curb

1. Verify that the roof mounting curb is correct for the unit. There are two curbs depending on the unit cabinet sizes:
 - A5PA3024-036 use model BAYCURB050,
 - A5PA3042-060 use model BAYCURB051
2. Assemble and install the curb following the instructions in the Installer's Guide included with the appropriate curb.

Table 2. Typical Ground Level Application

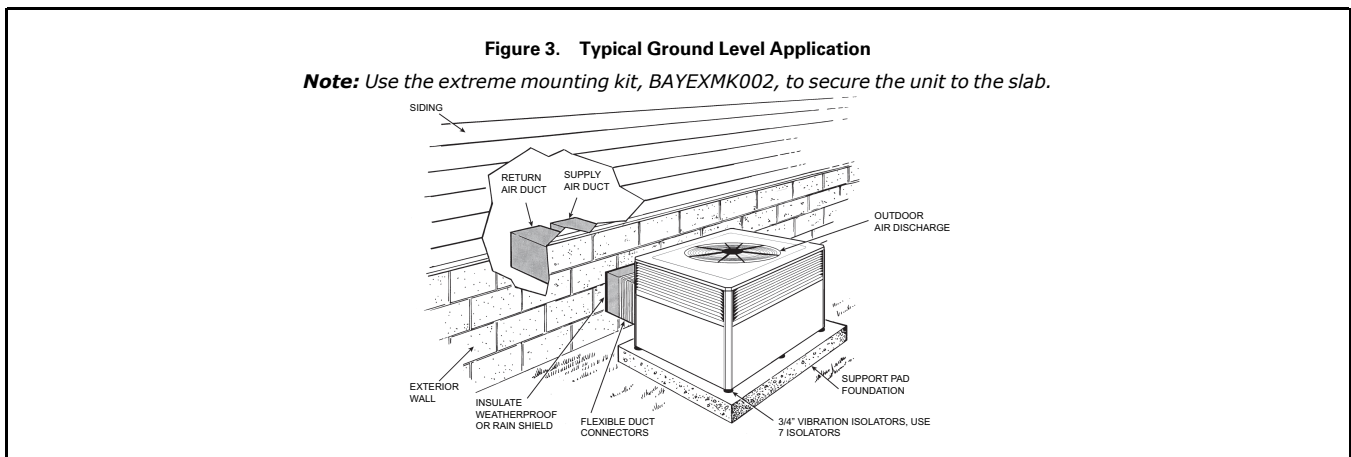
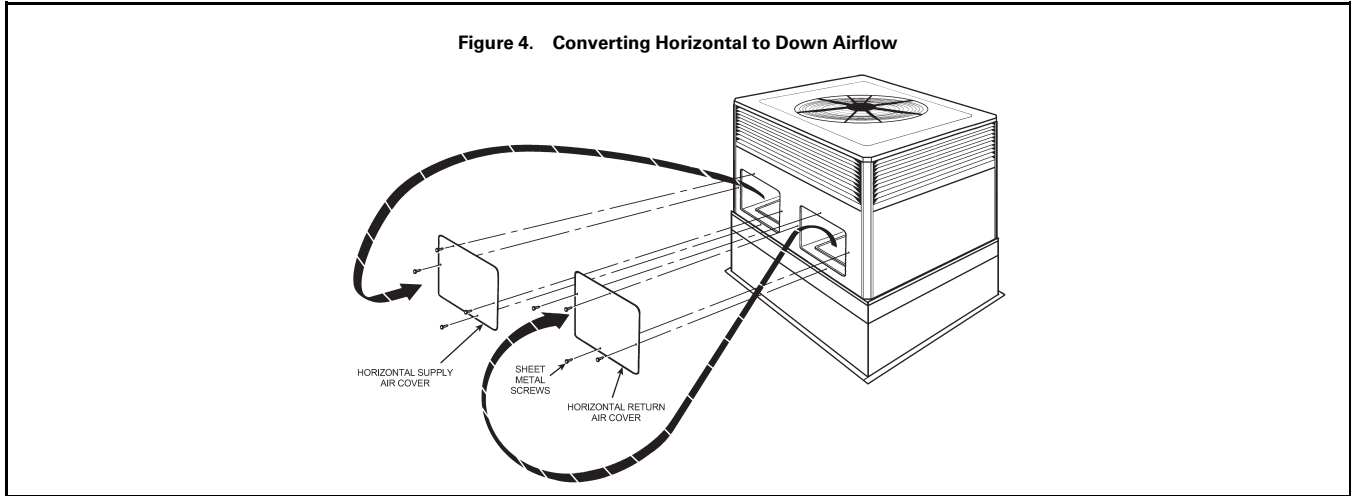

Table 3. Converting Horizontal to Down Airflow



Lifting and Rigging

⚠ WARNING

IMPROPER UNIT LIFT!

Failure to properly lift unit could result in death or serious injury or possible equipment or property-only damage.

Test lift unit approximately 24 inches to verify proper center of gravity lift point. To avoid dropping of unit, reposition lifting point if unit is not level.

Important: Do not lift the unit without test lifting for balance and rigging. Do not lift the unit in windy conditions or above personnel. Do not lift the unit by attaching clevis, hooks, pins, or bolts to the unit casing, casing hardware, corner lugs, angles, tabs, or flanges. Failure to observe these warnings may result in equipment damage.

1. Before preparing the unit for lifting, check the unit dimension drawings for center of gravity for lifting safety ("Determine Unit Clearances," p. 11). Because of placement of internal components, the unit's weight may be unevenly distributed. Approximate unit weights are also provided in the unit drawings.

Note: Unit rigging and hoisting requires accessory kit BAYLIFT002. It includes a kit of four (4) lifting lugs.

2. Insert the four lifting lugs in the openings provided in the drip lip on each end of the unit. A tap or jerk to the lug will overcome the interference that arises due to the dimple on the lug.
3. When hoisting the unit, be sure that a proper method of rigging is used. Use slings and spreader bars for protection during lifting. Always test-lift the

unit to determine the exact unit balance and stability before hoisting it to the installation location.

4. When the curb and air ducts have been properly installed, the unit is ready to be hoisted to the roof and set in position.

Important:

- To prevent damage to the sides and top of the unit when hoisting use "spreader bars".
- The unit must be lowered into position. The P.V.C. rubber tape on the curb flange permits the unit to be repositioned if required without destroying the P.V.C. rubber seals affixed to the mounting curb.

Placing the Unit on the Mounting Curb

1. The unit is designed with a perimeter drip lip that is lower than the unit base pan, see, [Table 5, p. 18](#).
2. Position the unit drip lip down over and in contact with the outside corner of the curb.. Continue to lower the unit on top of the curb, with the unit drip lip astraddle, and in contact with, both the end and side rail of the curb. The unit should now rest on top of the curb. Consider using the extreme mounting kit, BAYEXMK001, to add additional hold down strength to the mounting.

Notes:

- For rooftop applications, the use of extreme mounting kits and vibration isolators is optional and not mandatory.
- The ductwork is installed as part of the curb installation. Do not attach ductwork to the unit and lower the unit with ductwork onto the curb.

Table 4. Vibration Isolators/Snow Feet Locations

Note: The installation instructions indicate typical installation only, but actual installation may differ.

Note: These views represent the base as viewed looking up from underneath the unit.

Important: Unit vibration isolator support is *recommended* in the general areas shown. Locate 3/4" thick vibration isolators on the bottom of the basepan as illustrated by black dots for ground level pad applications. Modify vibration isolator location as necessary for frame and rail applications.

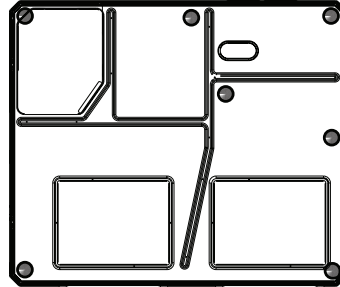

Small Cabinet
****024-036

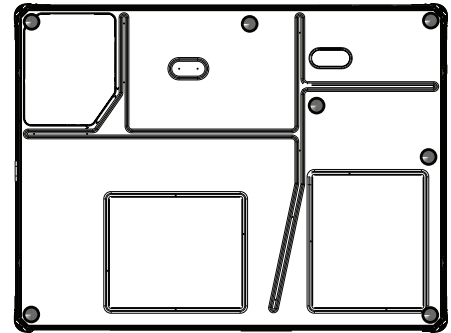

Medium Cabinet
****042-060

Rooftop Installation — Frame Mounting

For rooftop applications using field fabricated frame and ducts use the following procedure:

1. Locate and secure the frame to the roof by bolting or welding. Frame must provide adequate center support via a cross member centrally located channel rail. See, [Table 8, p. 19](#). Vibration isolators should be installed as indicated in [Table 4, p. 17](#), adjust as necessary for your frame. The isolators must be placed on base pan, not drip lip. Add flashing as required. Flashing must conform to local building codes.
2. Prepare the hole in the roof in advance of installing the unit.
3. Secure the horizontal or down airflow ducts to the roof. Refer to the previous Convert from Horizontal Airflow to Down Airflow section if conversion is needed.
4. All fabricated outdoor ducts should be as short as possible.
5. Place the unit on the frame.
6. The unit must be mounted level for proper drainage of water through the holes in the base pan.
7. Secure the unit to the frame.
8. Insulate any ductwork outside of the structure with at least two (2) inches of insulation and then weatherproof. There must be a weatherproof seal where the duct enters the structure.
9. The unit should not be exposed to direct roof water runoff.
10. Flexible duct connectors must be of a flame retardant material. All duct work outside of the structure must be insulated and weatherproofed in accordance with local codes.
11. Access and service clearances for the unit must be

given careful consideration when locating the duct entrance openings. "[Determine Unit Clearances,](#)" p. 11 provide unit dimensions.

12. Continue with the following installation sections to complete the installation: Ductwork, Filter, and Electrical Wiring.

Rooftop Installation — No Curb/Frame

For roof top applications using field fabricated ducts and sleeper rails rather than a curb or frame, use the following procedure:

1. Locate and secure the sleeper rails to the roof by bolting (three (3) rails required). One on each end to support the edges of the unit and one across the center of the unit. The center rail must run inside both drip lips. Vibration isolators should be installed, adjust as necessary for your sleeper rails. The isolators must be placed on base pan, not drip lip. Add flashing as required. Flashing must conform to local building codes.
2. Prepare the hole in the roof in advance of installing the unit.
3. Secure the horizontal or down airflow ducts to the roof. Refer to the previous Convert from Horizontal Airflow to Down Airflow section if conversion is needed.
4. All fabricated outdoor ducts should be as short as possible.
5. Place the unit on the rails.
6. The unit must be mounted level for proper drainage of water through the holes in the base pan.
7. Secure the unit to the rails.
8. Insulate any ductwork outside of the structure with at least two (2) inches of insulation and then weatherproof. There must be a weatherproof seal

Unit Installation

- where the duct enters the structure.
- 9. No exposure to direct roof water runoff.
- 10. Flexible duct connectors must be of a flame retardant material. All duct work outside of the structure must be insulated and weatherproofed in accordance with local codes.

- 11. Access and service clearances for the unit must be given careful consideration when locating the duct entrance openings. **"Determine Unit Clearances,"** p. 11 provide unit dimensions.
- 12. Continue with the following installation sections: Ductwork, Filter and Electrical Wiring.

Table 5. Lifting and Rigging

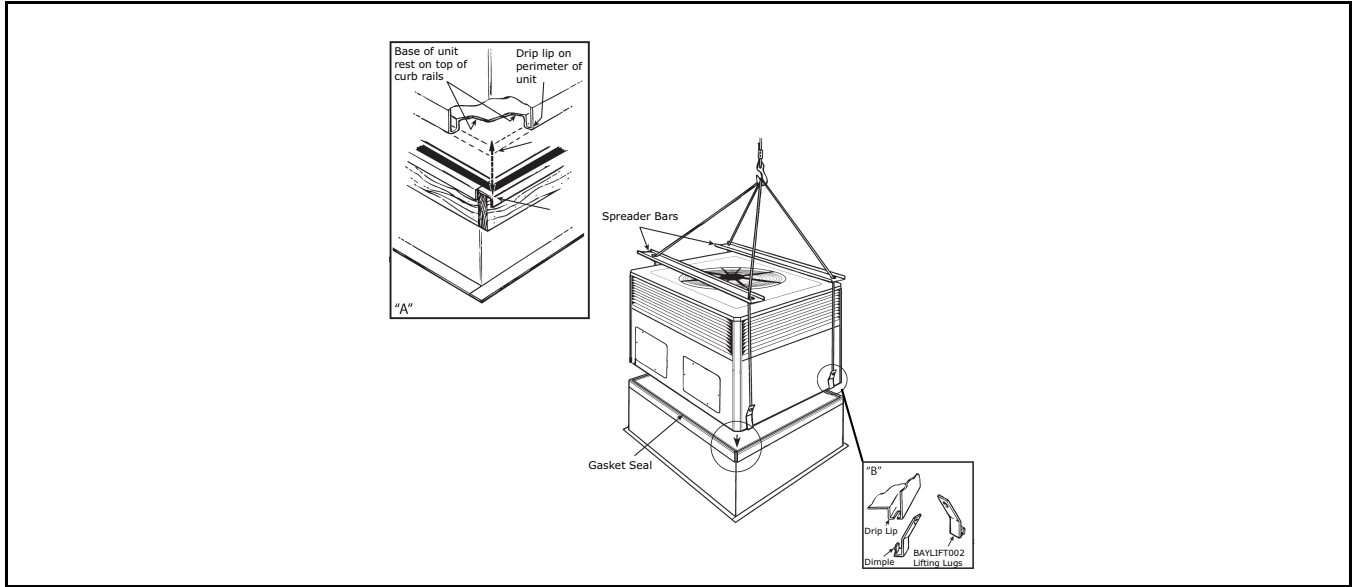
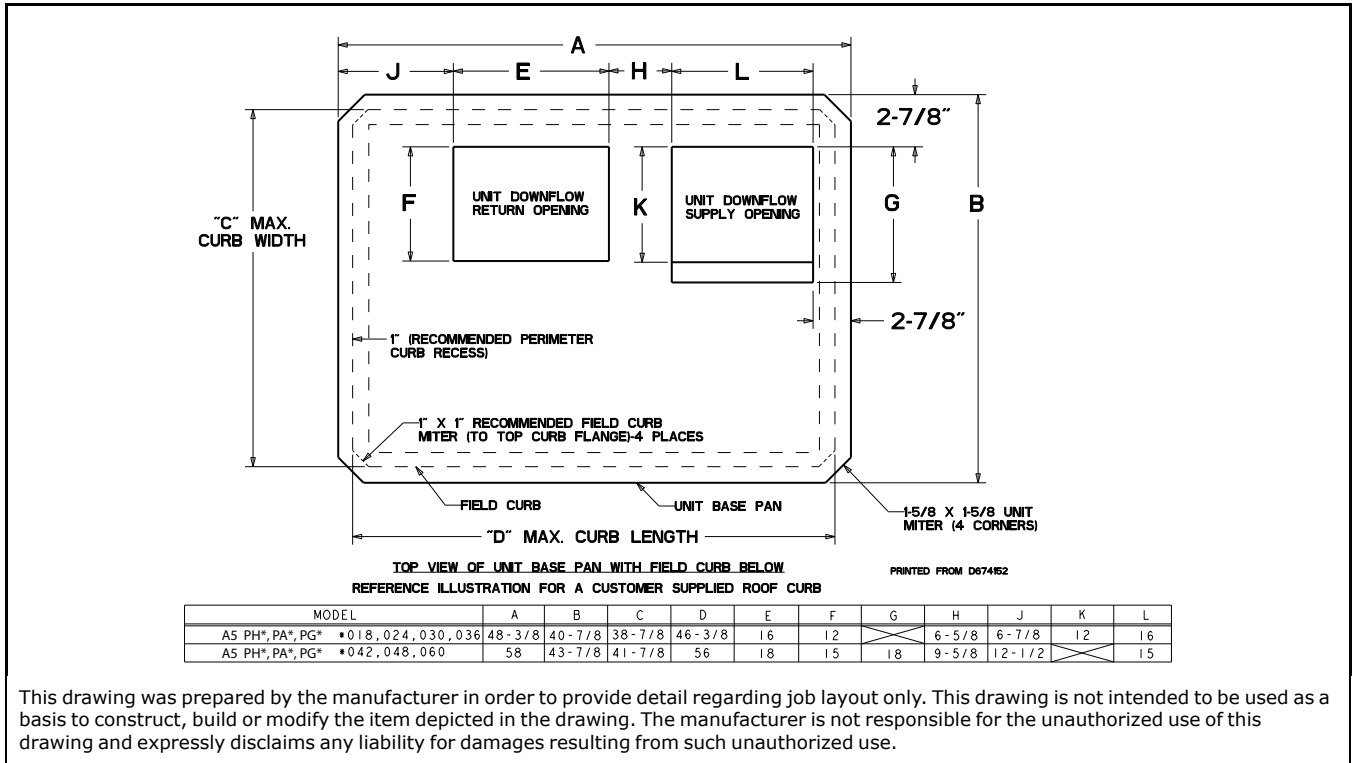

Table 6. Curb Dimensions



This drawing was prepared by the manufacturer in order to provide detail regarding job layout only. This drawing is not intended to be used as a basis to construct, build or modify the item depicted in the drawing. The manufacturer is not responsible for the unauthorized use of this drawing and expressly disclaims any liability for damages resulting from such unauthorized use.

Table 7. Typical Rooftop Horizontal Airflow Application with Frame

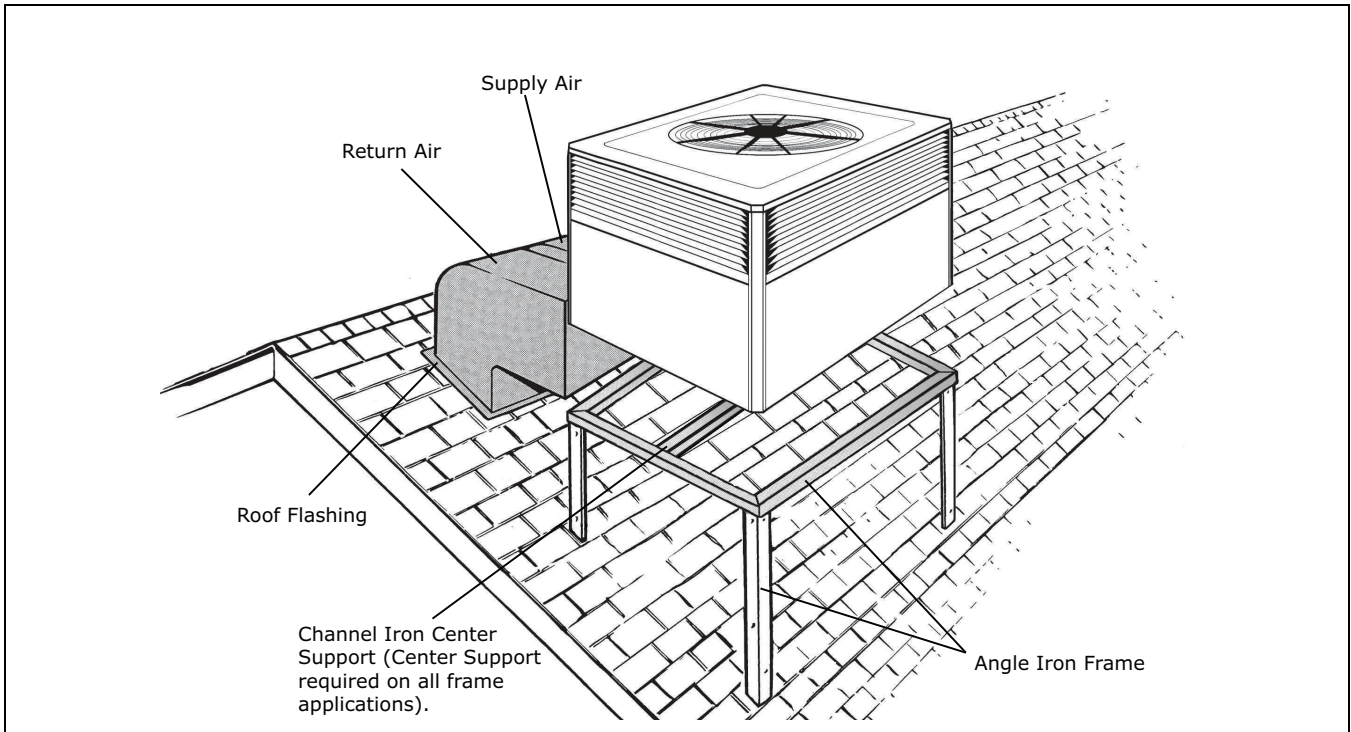
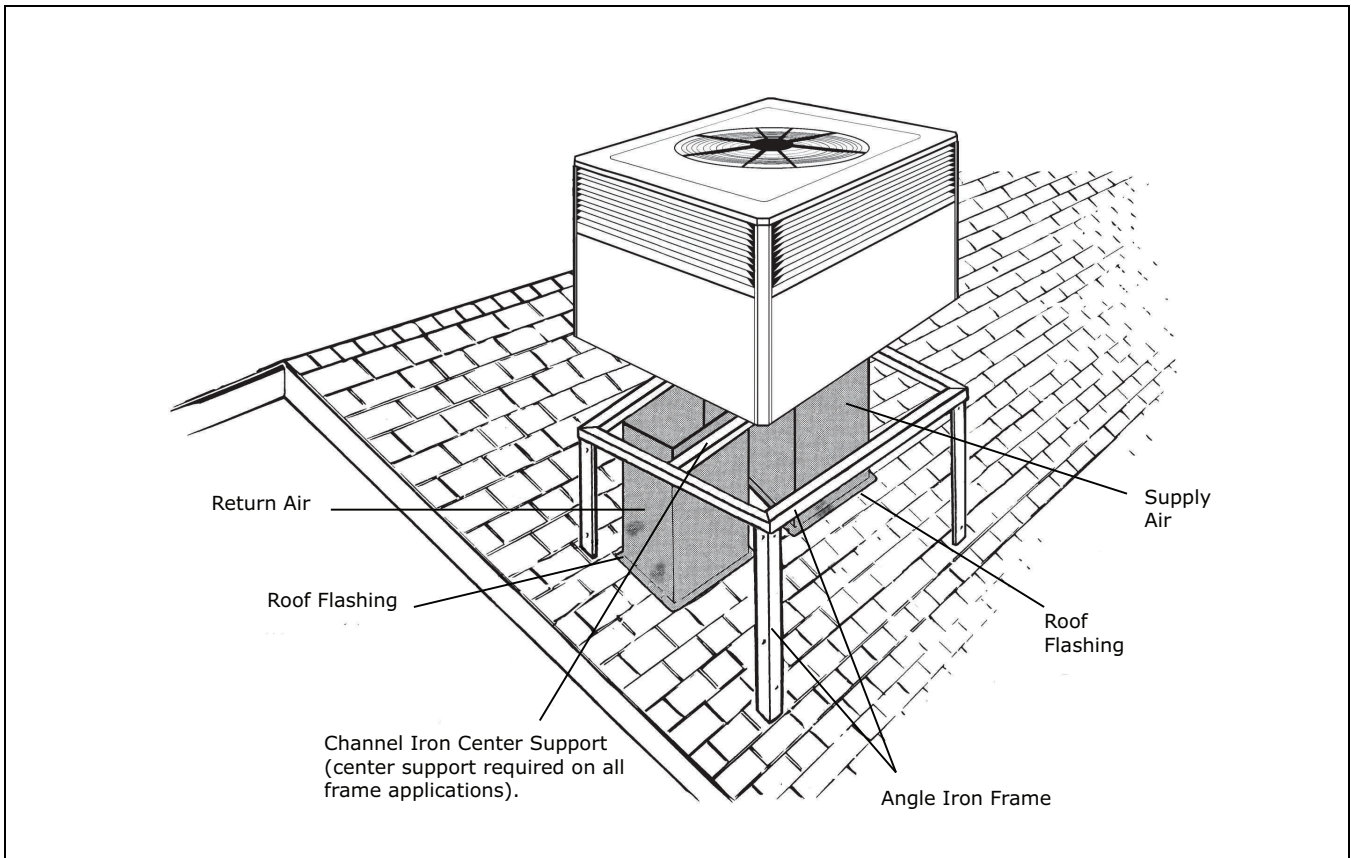

Table 8. Typical Rooftop Down Airflow Application with Frame



Ductwork Installation

Attaching Downflow Ductwork to Roof Curb

Supply and return air flanges are provided on the roof curb for easy duct installation. All ductwork must be run and attached to the curb before the unit is set into place.

Attaching Downflow Ductwork to Roof Frame

Follow these guidelines for ductwork construction:

Connections to the unit should be made with three (3) inch canvas connectors to minimize noise and vibration transmission.

Elbows with turning vanes or splitters are recommended to minimize air noise and resistance.

The first elbow in the ductwork leaving the unit should be no closer than two (2) feet from the unit, to minimize noise and resistance.

To prevent leaking, do not attach the ductwork to the bottom of the unit base. Refer to the bottom example in the figure below.

Figure 5. Attaching Down Airflow Ductwork

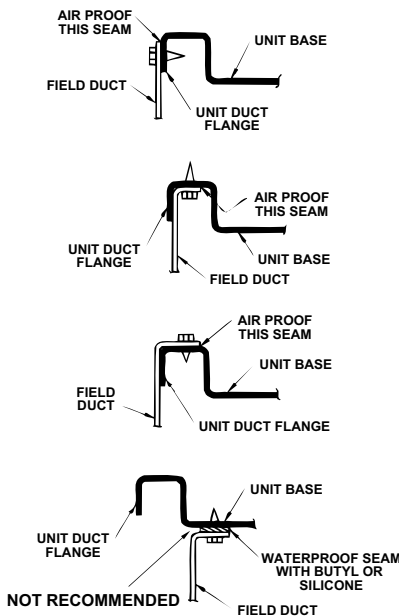

Attaching Horizontal Ductwork to Unit

All conditioned air ductwork should be insulated to minimize heating and cooling duct losses. Use a minimum of two (2) inches of insulation with a vapor barrier. The outside ductwork must be weatherproofed between the unit and the building.

When attaching ductwork to a horizontal unit, provide a flexible watertight connection to prevent noise transmission from the unit to the ducts. The flexible

connection **must** be indoors and made out of heavy canvas.

Note: Do not draw the canvas taut between the solid ducts.

Figure 6. Attaching Horizontal Airflow Ductwork

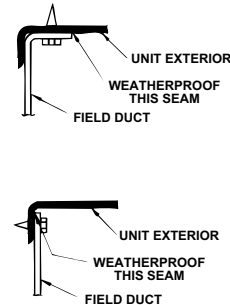

Condensate Drain Piping

A 3/4-inch female NPT condensate drain connection is provided on the evaporator access panel end of the unit. Provide a trap and fill it with water before starting the unit to avoid air from being drawn through. Follow local codes and standard piping practices when running the drain line. Pitch the line downward away from the unit. Avoid long horizontal runs. See [Figure 7, p. 20](#).

Note: Do not use reducing fittings in the drain lines.

The condensate drain must be:

- Made of 3/4" pipe size
- Pitched 1/4" per foot to provide free drainage to convenient drain system
- Trapped
- Must be connected to a closed drain system unless the trap is properly vented

Figure 7. Typical Condensate Drain Piping

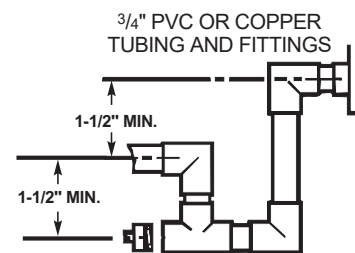

Air Filter Installation

The packaged unit requires an air filter. The unit does not come with a factory installed filter rack in it, however, two filter frame accessories are offered that will allow the installation of a filter within the unit, BAYFLTR101 & BAYFLTR201. Otherwise a field supplied filter rack must be installed by the installer in the return duct work. Refer to table for field supplied filter racks.

Table 9. Filter Sizes (field supplied filter rack)

UNIT	NOMINAL CFM	FILTER ^(a) SIZE (Sq Ft)	FILTER RESISTANCE ("W.C.)
A5PA3024	800	2.67	0.08
A5PA3030	1000	3.33	0.08
A5PA3036	1200	4.00	0.08
A5PA3042	1400	4.67	0.08
A5PA3048	1600	5.33	0.08
A5PA3060	2000	6.67	0.08

^(a) Filters must be installed in the return air system. The above square footages are based on 300 F.P.M. face velocity. If permanent filters are used, size per mfg. Recommendation with clear resistance of 0.05"W.C.

Important: Air filters and media wheels or plates shall meet the test requirements in UL 900.

Electrical Wiring

Note: This unit is factory wired for 230V. See wiring diagram for 208V conversion.

Electrical Connections

Electrical wiring and grounding must be installed in accordance with local codes or, in the absence of local codes, with the National Electrical Code ANSI/NFPA 70, Latest Revision.

Electrical Power

It is important that proper electrical power be available for the unit. Voltage variation should remain within the limits stamped on the unit nameplate.

Disconnect Switch

Provide an approved weatherproof disconnect within close proximity and **within sight of the unit**. If disconnect must be mounted to the cabinet, the location shown in [Table 12, p. 21](#) should be the only one considered.

Over Current Protection

The branch circuit feeding the unit must be protected as shown on the unit's rating plate.

Power Wiring

The power supply lines must be run in weather-tight conduit to the disconnect and into the side of the unit control box. Provide strain relief for all conduit with suitable connectors.

Provide flexible conduit supports whenever vibration transmission may cause a noise problem within the building structure.

1. Remove the Control/Heat access panel. Pass the power wires through the Power Entry hole in the end of the unit. See [Table 10, p. 21](#).
2. Connect the high voltage wires to the appropriate contactor terminals. Single phase units use a two

(2) pole contactor and three phase units use three (3) pole contactor. Connect the ground to the ground lug on the chassis. See [Table 12, p. 21](#).

Ensure all connections are tight.

Table 10. Power Wiring

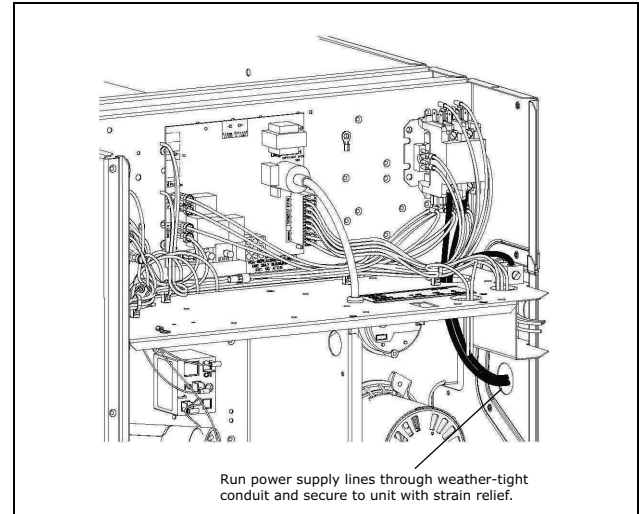

Table 11. Power Connections

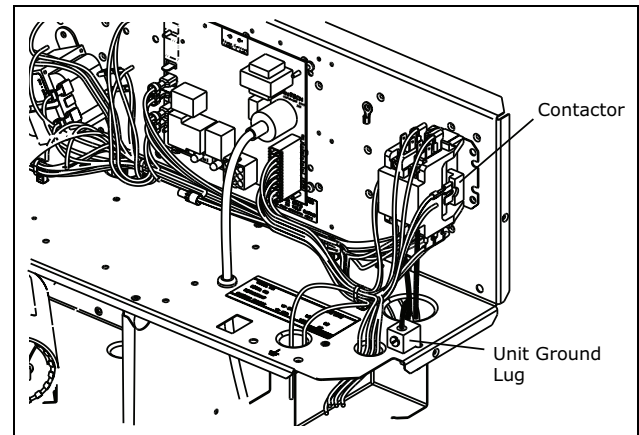
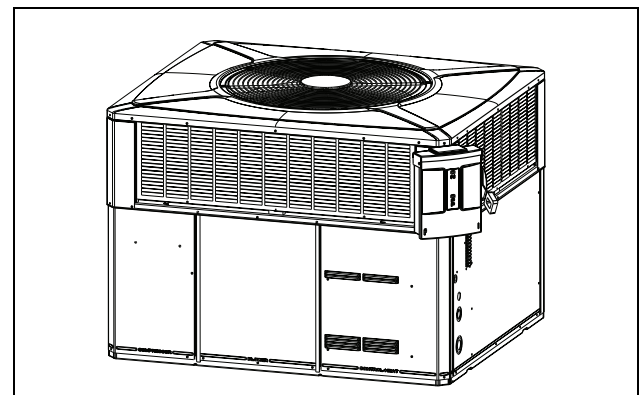

Table 12. Mounted Disconnect Location



Unit Installation

Table 13. Field Wiring Diagram

Notes:

1. Fused disconnect size, power wiring and grounding of equipment must comply with codes..
2. Be sure power supply agrees with equipment and heater nameplate.
3. Low voltage wiring to be 18 AWG minimum conductor.
4. See heater nameplate for current rating of heater used.
5. See unit and heater diagram for electrical connection details.
6. Jumper must be connected between 1 and 2 for fan to operate in heating.
7. Some thermostats provide the 'G' signal in the cooling mode only. To provide the 'G' signal in the heating mode an accessory relay is required. See fig. 3 for proper connections.
8. For cooling only omit the electric heater, associated power wires and the 'W' signal thermostat wire.
9. Fig. 4 demonstrates connection of the two stage electric heat thermostat accessory only. For further unit connection details refer to the other figures.
10. The 41A (BR) wire is first stage electric heat. If the electric heater accessory has two heating stages the 41C (BR) wire is second stage electric heat.

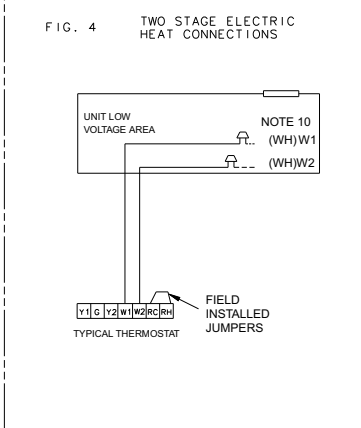
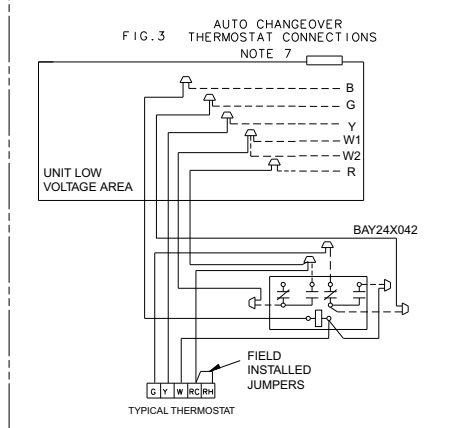
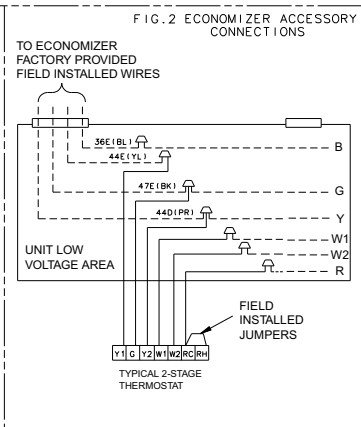
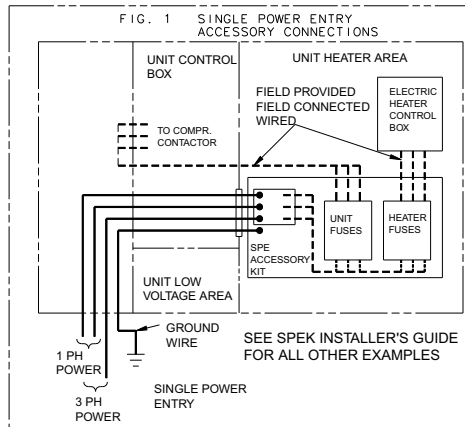
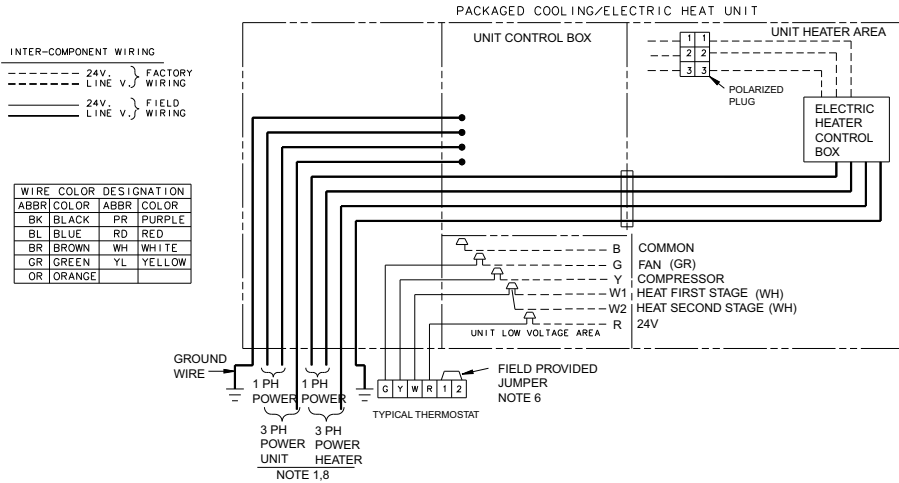

7569772

Control Wiring (Class II)

Low voltage control wiring should not be run in conduit with power wiring unless Class 1 wire of proper voltage rating is used. Route the thermostat cable or equivalent single leads of No. 18 AWG colored wire from the thermostat subbase terminals through the rubber grommet on the unit. See Figures 1–6 for the control entry (24V Entry) location. Make connections as shown on [Table 13, p. 22](#).

Do not short thermostat wires since this will damage the control transformer.

Refer to the table below for recommended wire sizes and lengths for installing the unit thermostat. The total resistance of these low voltage wires must not exceed one (1) ohm. Any resistance in excess of 1 ohm may cause the control to malfunction because of the excessive voltage drop.

Table 14. Thermostat Wire Size and Maximum Length

Wire Size	Maximum Length (Ft)
18	75
16	125
14	200

Important: Upon completion of wiring, check all electrical connections, including factory wiring within the unit, and make sure all connections are tight. Replace and secure all electrical box covers and access panels before leaving the unit or turning on the power to the unit.

Unit Startup

Pre-Start Quick Checklist

- Is the unit properly located and level with the proper clearances? See, “[Determine Unit Clearances](#),” p. 11.
- Is the duct work correctly sized, run, taped, insulated, and weatherproofed with proper unit arrangement as shown in the ductwork installation section?
- Is the condensate line properly sized, run, trapped, and pitched and shown in the Condensate Drain Piping section?
- Is the filter of the correct size and quantity? Is it clean and in place? See Air Filter Installation section.
- Is the wiring properly sized and run according to the unit wiring diagram?
- Are all the wiring connections, including those in the unit tight?
- Has the unit been properly grounded and fused with the recommended fuse size?
- Is the thermostat well located, level, and correctly wired? See Electrical Wiring section
- Have the air conditioning systems been checked at the service ports for charge and leak tested if necessary?
- Do the condenser fan and indoor blower turn free without rubbing and are they tight on the shafts?
- Has all work been done in accordance with applicable local and national codes?
- Are all covers and access panels in place to prevent air loss and safety hazards?
- Has the appropriate appearance label been installed as shown in [Figure 1](#), p. 11.

Starting the Unit in Cooling Mode

Note: See the section on *Sequence of Operation* for a description of the cooling operating sequence.

To start the unit in the cooling mode, set the comfort control to **COOL** and to a setting below room temperature. The condenser fan motor, compressor and evaporator fan motor will operate automatically. Continuous fan mode during Cooling operation may not be appropriate in humid climates. If the indoor air exceeds 60% relative humidity or simply feels uncomfortably humid, it is recommended that the fan only be used in the **AUTO** mode.

Operating Pressure Checks

After the unit has operated in the cooling mode for a short period of time, install pressure gauges on the gauge ports of the discharge and suction line valves (behind the Compressor access panel). Check the suction and discharge pressures and compare them to the normal operating pressures provided in the unit’s SERVICE FACTS.

Note: Do not use the *PRESSURE CURVES* from the unit’s SERVICE FACTS to determine the unit refrigerant charge. The correct charge is shown on the unit nameplate. To charge the system accurately, weigh in the charge according to the unit nameplate and check subcooling against the Subcooling Charging Table in the SERVICE FACTS.

Voltage Check

With the compressor operating, check the line voltage at the unit (contactor is located behind the Control access panel). The voltage should be within the range shown on the unit nameplate. If low voltage is encountered, check the size and length of the supply line from the main disconnect to the unit. The line may be undersized for the length of the run.

Cooling Shut Down

Set the comfort control to **OFF** or to a setting above room temperature.

Important: De-energize the main power disconnect *ONLY* when servicing the unit. Power may be required to keep the heat pump compressor warm and to boil off refrigerant in the compressor.

Starting the Unit in Heating Mode

Note: See the section on *Sequence of Operation* for a description of the heat pump heating operating sequence.

Check that all grills and registers are open and all unit access panels are closed before start-up.

Set the comfort control above room temperature until achieving a first stage call for heat and set the fan to **AUTO** or **ON**.

Heating Shut Down

Set the comfort control to **OFF** or at a setting below room temperature.

Sequence of Operation

General

Operation of the unit heating and cooling cycles is automatic when the system is in the **HEAT** or **COOL** functions (the optional automatic changeover thermostat, when in the **AUTO** position, automatically changes to heat or cool with an appropriate room temperature change). The fan can be set to **ON**, causing continuous evaporator (indoor) fan operation or set to **AUTO** causing fan operation to coincide with heating or cooling run cycles. Continuous fan mode during Cooling operation may not be appropriate in humid climates. If the indoor air exceeds 60% relative humidity or simply feels uncomfortably humid, it is recommended that the fan only be used in the **AUTO** mode.

Cooling Mode

Note: The TSH and TSC are contacts that are internal to the indoor comfort control.

With the disconnect switch in the **ON** position, current is supplied to the control transformer. The cooling cycle is enabled through the low voltage side of the control transformer to the "R" terminal on the indoor thermostat. With the comfort control set to **AUTO** and **TSC-1** contacts closed, power is supplied to the "O" terminal on the indoor thermostat to the switchover valve coil (**SOV**). This energizes the switch-over valve (**SOV**) and places it in the cooling position (it is in the heating position when de-energized).

When the indoor temperature rises 1-1/2 degrees, **TSC-2** contacts close, supplying power to the "Y" terminal on the indoor thermostat, and to the compressor contactor (**CC**). This starts the outdoor fan motor and compressor. The **TSC-2** contacts also provide power to the "G" terminal which provides power to the indoor fan motor.

Heating Mode

With the comfort control set to **ON**, current is supplied to the transformer. Starting at the "R" terminal on the indoor comfort control, current goes through the system switch (which is in "AUTO" position) to the **TSH-1** contacts. When closed, these contacts supply power to terminal "Y" on the indoor thermostat as well as to the heating anticipator. The switch-over valve will not energize because of the high resistance of the heating anticipator in the thermostat. Power is provided from "Y" to the compressor contactor (**CC**)

which starts the compressor and outdoor fan motor. The indoor thermostat contact **TSH-1** also provides power to "G" terminal on the indoor thermostat energizing the indoor fan motor.

Supplementary Heat

The supplementary electric heat is brought on when the indoor temperature drops 1-1/2 degrees below the thermostat setting. **TSH-2** contacts close providing power to the "W" terminal on the indoor thermostat and to the supplementary heater control circuit. An outdoor thermostat may have been added to disallow the second stage (if provided) of electric heat above a selected outdoor temperature. If the outdoor temperature falls below the setting on the outdoor thermostat, this additional heater stage will come on. When the outdoor air temperature rises, and the outdoor T-stat setpoint is reached, the system will revert back to first stage electric heating.

When the indoor ambient is satisfied, **TSH-2** contacts will open and the unit will revert back to the compressor only heating mode and then off. For **emergency heat** (use of supplementary electric heat only), an emergency (**EMERG**) heat switch is provided within the comfort control. When placed in the emergency heat position, it will disable the compressor, bypass the outdoor thermostats, if provided, and engage the supplementary electric heaters and indoor fan.

Demand Defrost Operation

During the heating cycle, the outdoor coil may require a defrost cycle which is determined by the demand defrost control (**DFC**). This control continuously measures the outdoor coil temperature (**CBS**) and the outdoor ambient temperature (**ODS-B**) and calculates the difference or delta-T measurement. When the calculated delta-T is met, the demand defrost control (**DFC**) opens the circuit to the outdoor fan motor (**ODM**) and energizes the switch-over valve (**SOV**), placing the unit in the cooling mode to defrost the outdoor coil. The outdoor coil temperature sensor (**CBS**) terminates the defrost cycle, or times out after fifteen minutes in defrost, the (**DFC**) energizes the outdoor fan motor (**ODM**) and twelve seconds later de-energizes the (**SOV**), which returns the unit to the heating mode. Supplementary electric heat, if provided, is brought on to control indoor temperature during the defrost cycle.

Final Installation Checklist

Important: Perform a final unit inspection to be sure that factory tubing has not shifted during shipment. Adjust tubing if necessary so tubes do not rub against each other when the unit runs. Also be sure that wiring connections are tight and properly secured.

- Does the unit run and operate as described in the Sequence of Operation section in response to the room thermostat?
- Are the condenser fan and indoor blower operating correctly with proper rotation and without undue noise?
- Is the compressor operating correctly and has the system been checked with a charging chart?
- Has the voltage and running current been checked to determine if it is within limits?
- Has the thermostat been checked for calibration and the air discharge grills adjusted to balance the system?
- Has the ductwork been checked for air leaks and condensation?
- Has the furnace manifold pressure been checked and adjusted if necessary?
- Has the heating air temperature rise been checked?
- Has the unit been checked for tubing and sheet metal rattles? Are there any other unusual noises to be checked?
- Has all mitigation actions been verified?
- Are all covers and panels in place and properly fastened?
- Has the owner been instructed on the proper operation and maintenance of the unit? Be sure to leave this manual with the owner.

Verification of Mitigation Actions

After installation, the installer must verify that the refrigerant leak detection system actuates all mitigating actions.

The test can be initiated by shorting the two test pins on the header of the mitigation control board inside of the unit. The mitigating actions will continue for approximately 5 minutes. See [Figure 8, p. 26](#) below.

Figure 8. MCB

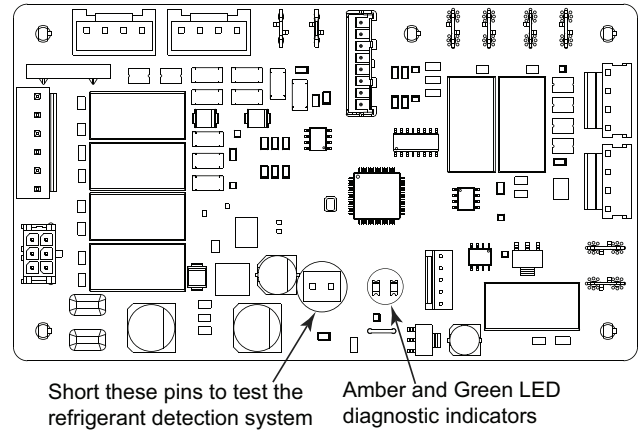

If any of the mitigating actions are not actuated by the system during the test, please check the following:

- All field wiring connections should be checked against the diagrams in the section of this manual.
- The diagnostic indicators on the mitigation control board should be checked against the diagnostic codes given in below.
- Scan the QR code below for more information on field troubleshooting of the refrigerant leak detection system.

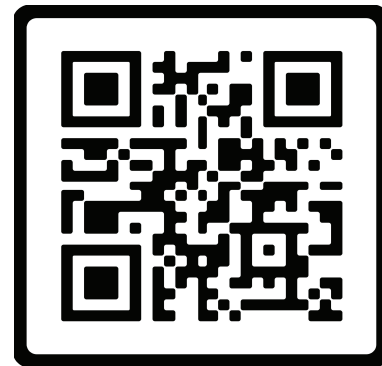

Table 15. MCB Diagnostic Code Table

Condition	Green LED	Amber LED
Idle or Off	Off	Off
Startup	On	On
No Active Alarm	Slow Flash	On
Active Alarm (Refrigerant Leak, Sensor Communicating Error, or Sensor Error)	3 Flash	On
Past Refrigerant Detected Alarm	4 Flash	On
Past Sensor Communication Error	5 Flash	On
Past Sensor Error	6 Flash	On

Maintenance

Owner Maintenance

Some of the periodic maintenance functions of the unit can be performed by the owner; this includes replacing the disposable or cleaning the permanent air filters, cleaning the unit cabinet, cleaning the condenser coil, and conducting a general unit inspection on a regular basis.

Filters

When the system is in constant operation, inspect the filters at least once each month.

If the unit has disposable-type filters, replace them with new filters of the same type and size. **Do not attempt to clean disposable filters.**

Permanent-type filters can be cleaned by washing them with a mild detergent and water. Make sure that the filters are thoroughly dry before reinstalling them in the unit (or duct system).

Note: *It may be necessary to replace permanent filters annually if washing fails to clean the filter or if the filter shows signs of deterioration. Be sure to use the same type and size as was originally installed.*

Condenser Coil

Be sure to keep all vegetation and debris away from the condenser coil area.

Service Maintenance

Cooling Season

To keep the unit operating safely and efficiently, the manufacturer recommends that a qualified service technician check the entire system at least once each year or sooner if needed. The service technician should examine these areas of the unit:

- filters (for cleaning or replacement)
- motors and drive system components
- economizer gaskets (for possible replacement)
- safety controls (for mechanical cleaning)
- electrical components and wiring (for possible replacement and connection tightness)
- condensate drain (for proper sealing and cleaning)
- unit duct connections (to see that they are physically sound and sealed to the unit casing)
- unit mounting support (for structural integrity)
- the unit (for obvious unit deterioration)

Heating Season

Complete the following unit inspections and service routines at the beginning of each heating season.

- Visually inspect the unit to ensure that the airflow required for combustion and condenser coil is not obstructed from the unit.
- Inspect the control panel wiring to verify that all electrical connections are tight and that the wire insulation is intact.

Indoor Airflow Motor Speed Tap Setting

The units are factory set to medium low speed. If an electric Heater is installed refer to the electric heater nameplate for minimum airflow settings.

Pressure Curves

Figure 9. Pressure Curves for A5PA3024

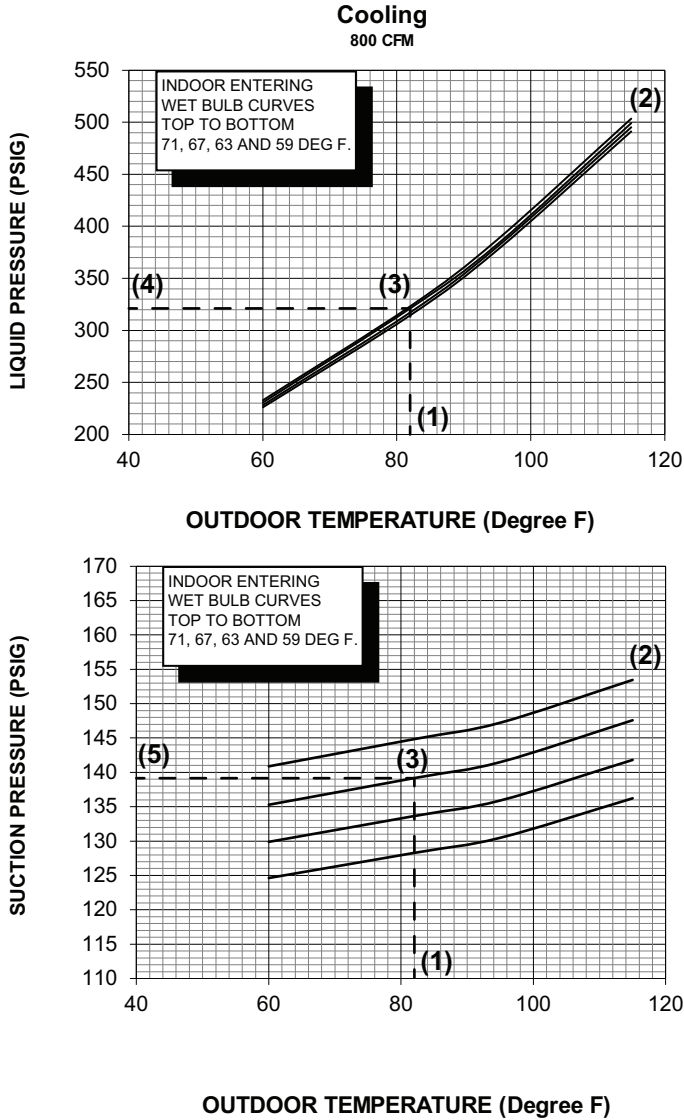

COOLING PERFORMANCE CAN BE CHECKED WHEN THE OUTDOOR TEMP IS ABOVE 65 DEG F.

TO CHECK COOLING PERFORMANCE, SELECT THE PROPER INDOOR CFM, ALLOW PRESSURES TO STABILIZE. MEASURE INDOOR WET BULB TEMPERATURE, OUTDOOR TEMPERATURE, DISCHARGE AND SUCTION PRESSURES. ON THE PLOTS LOCATE OUTDOOR TEMPERATURE (1); LOCATE INDOOR WET BULB (2); FIND INTERSECTION OF OD TEMP. & ID W.B. (3); READ DISCHARGE OR SUCTION PRESSURE IN LEFT COLUMN (4).

EXAMPLE: (1) OUTDOOR TEMP. 82 F.
 (2) INDOOR WET BULB 67 F.
 (3) AT INTERSECTION
 (4) DISCHARGE PRESSURE @ 800 CFM IS 321 PSIG.
 (5) SUCTION PRESSURE @ 800 CFM IS 139 PSIG.

ACTUAL:
 DISCHARGE PRESSURE SHOULD BE +/- 10 PSI OF CHART
 SUCTION PRESSURE SHOULD BE +/- 3 PSIG OF CHART

DWG.NO. A5PA3024

Figure 10. Pressure Curves for A5PA3030

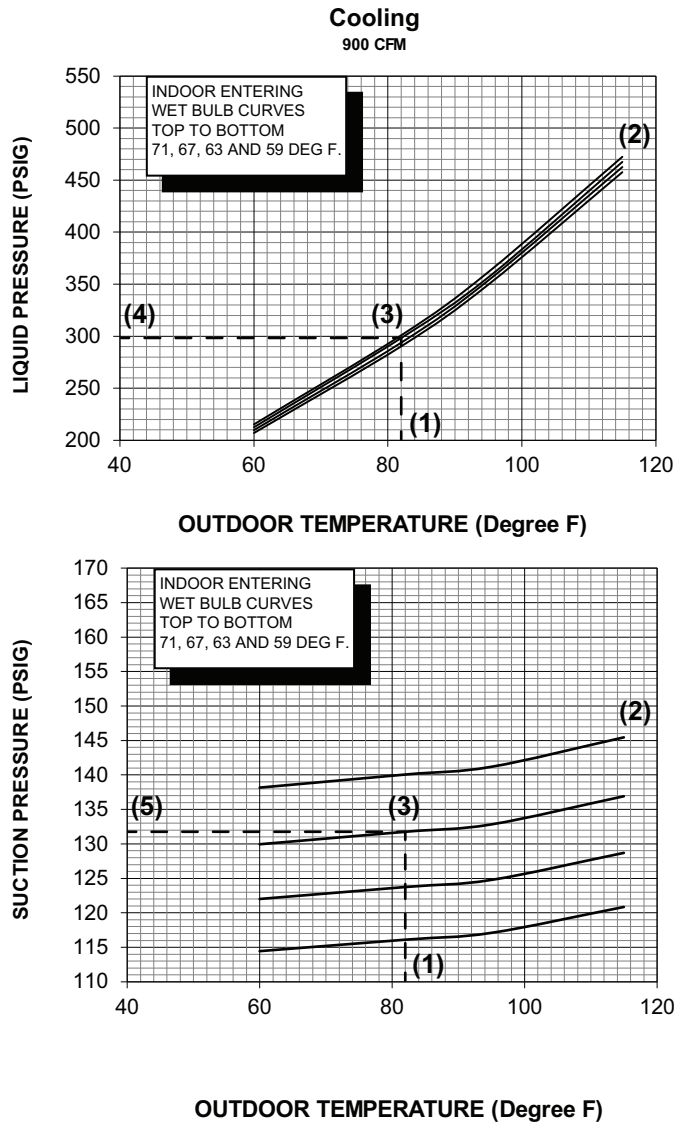

COOLING PERFORMANCE CAN BE CHECKED WHEN THE OUTDOOR TEMP IS ABOVE 65 DEG F.

TO CHECK COOLING PERFORMANCE, SELECT THE PROPER INDOOR CFM, ALLOW PRESSURES TO STABILIZE. MEASURE INDOOR WET BULB TEMPERATURE, OUTDOOR TEMPERATURE, DISCHARGE AND SUCTION PRESSURES. ON THE PLOTS LOCATE OUTDOOR TEMPERATURE (1); LOCATE INDOOR WET BULB (2); FIND INTERSECTION OF OD TEMP. & ID W.B. (3); READ DISCHARGE OR SUCTION PRESSURE IN LEFT COLUMN (4).

EXAMPLE: (1) OUTDOOR TEMP. 82 F.
 (2) INDOOR WET BULB 67 F.
 (3) AT INTERSECTION
 (4) DISCHARGE PRESSURE @ 900 CFM IS 298 PSIG.
 (5) SUCTION PRESSURE @ 900 CFM IS 132 PSIG.

ACTUAL:
 DISCHARGE PRESSURE SHOULD BE +/- 10 PSI OF CHART
 SUCTION PRESSURE SHOULD BE +/- 3 PSIG OF CHART

DWG.NO. A5PA3030

Figure 11. Pressure Curves for A5PA3036

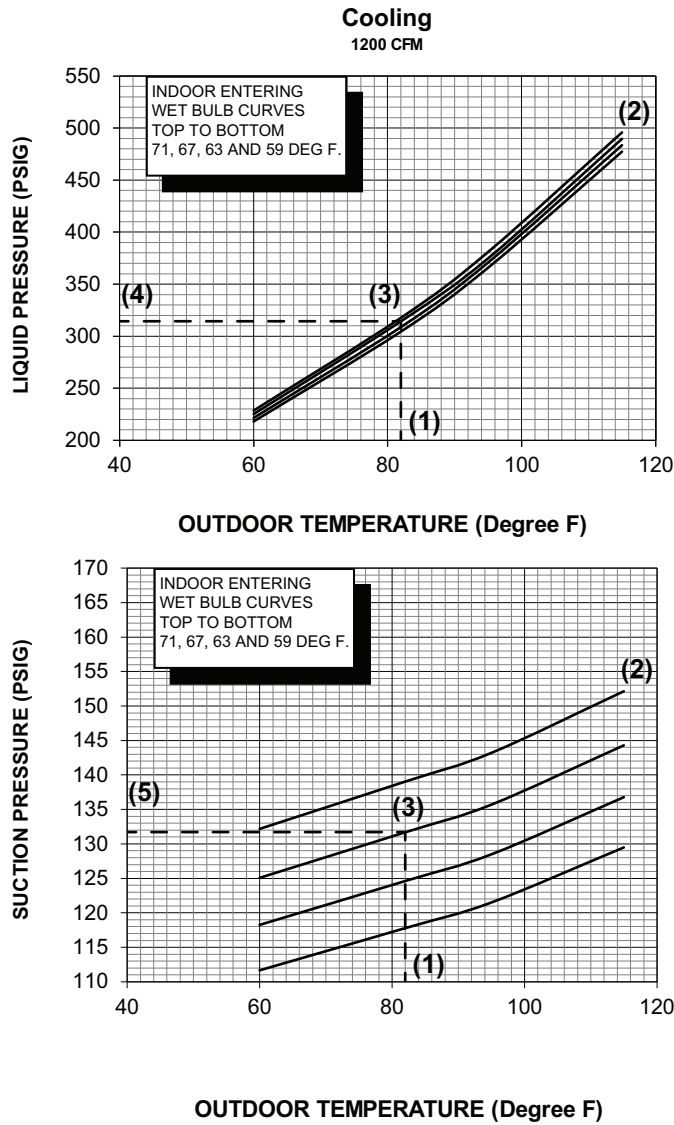

COOLING PERFORMANCE CAN BE CHECKED WHEN THE OUTDOOR TEMP IS ABOVE 65 DEG F.

TO CHECK COOLING PERFORMANCE, SELECT THE PROPER INDOOR CFM, ALLOW PRESSURES TO STABILIZE. MEASURE INDOOR WET BULB TEMPERATURE, OUTDOOR TEMPERATURE, DISCHARGE AND SUCTION PRESSURES. ON THE PLOTS LOCATE OUTDOOR TEMPERATURE (1); LOCATE INDOOR WET BULB (2); FIND INTERSECTION OF OD TEMP. & ID W.B. (3); READ DISCHARGE OR SUCTION PRESSURE IN LEFT COLUMN (4).

EXAMPLE: (1) OUTDOOR TEMP. 82 F.
 (2) INDOOR WET BULB 67 F.
 (3) AT INTERSECTION
 (4) DISCHARGE PRESSURE @ 1200 CFM IS 314 PSIG.
 (5) SUCTION PRESSURE @ 1200 CFM IS 132 PSIG.

ACTUAL:
 DISCHARGE PRESSURE SHOULD BE +/- 10 PSI OF CHART
 SUCTION PRESSURE SHOULD BE +/- 3 PSIG OF CHART

DWG.NO. A5PA3036

Figure 12. Pressure Curves for A5PA3042

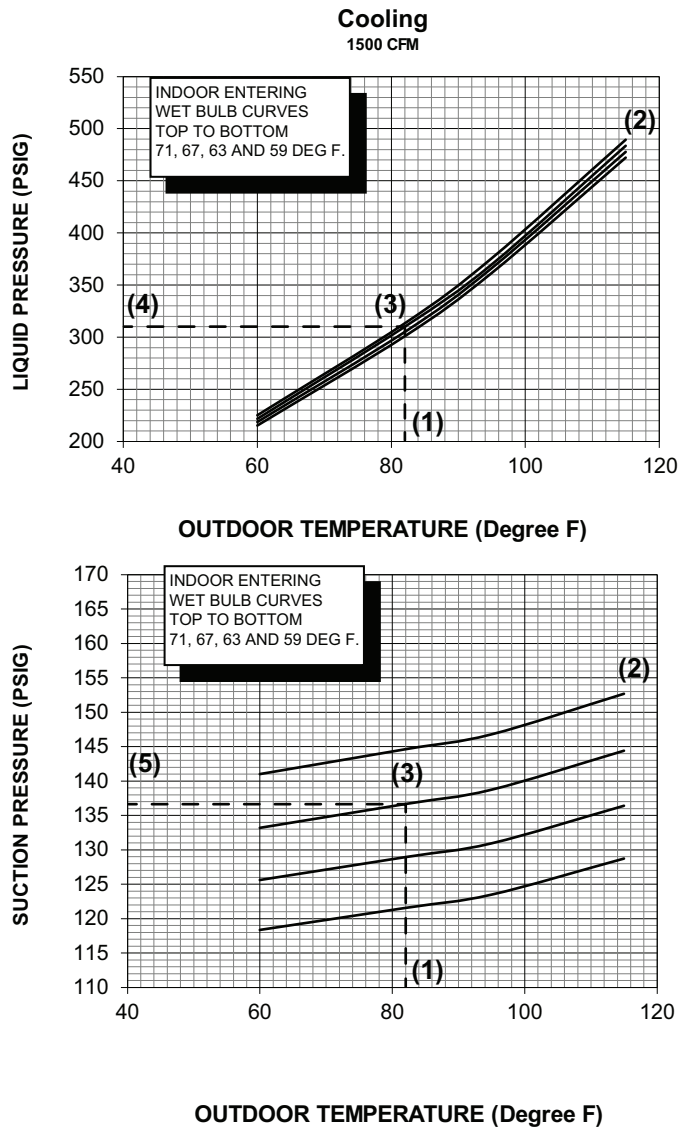

COOLING PERFORMANCE CAN BE CHECKED WHEN THE OUTDOOR TEMP IS ABOVE 65 DEG F.

TO CHECK COOLING PERFORMANCE, SELECT THE PROPER INDOOR CFM, ALLOW PRESSURES TO STABILIZE. MEASURE INDOOR WET BULB TEMPERATURE, OUTDOOR TEMPERATURE, DISCHARGE AND SUCTION PRESSURES. ON THE PLOTS LOCATE OUTDOOR TEMPERATURE (1); LOCATE INDOOR WET BULB (2); FIND INTERSECTION OF OD TEMP. & ID W.B. (3); READ DISCHARGE OR SUCTION PRESSURE IN LEFT COLUMN (4).

EXAMPLE: (1) OUTDOOR TEMP. 82 F.
 (2) INDOOR WET BULB 67 F.
 (3) AT INTERSECTION
 (4) DISCHARGE PRESSURE @ 1500 CFM IS 310 PSIG.
 (5) SUCTION PRESSURE @ 1500 CFM IS 137 PSIG.

ACTUAL:
 DISCHARGE PRESSURE SHOULD BE +/- 10 PSI OF CHART
 SUCTION PRESSURE SHOULD BE +/- 3 PSIG OF CHART

DWG.NO. A5PA3042

Figure 13. Pressure Curves for A5PA3048

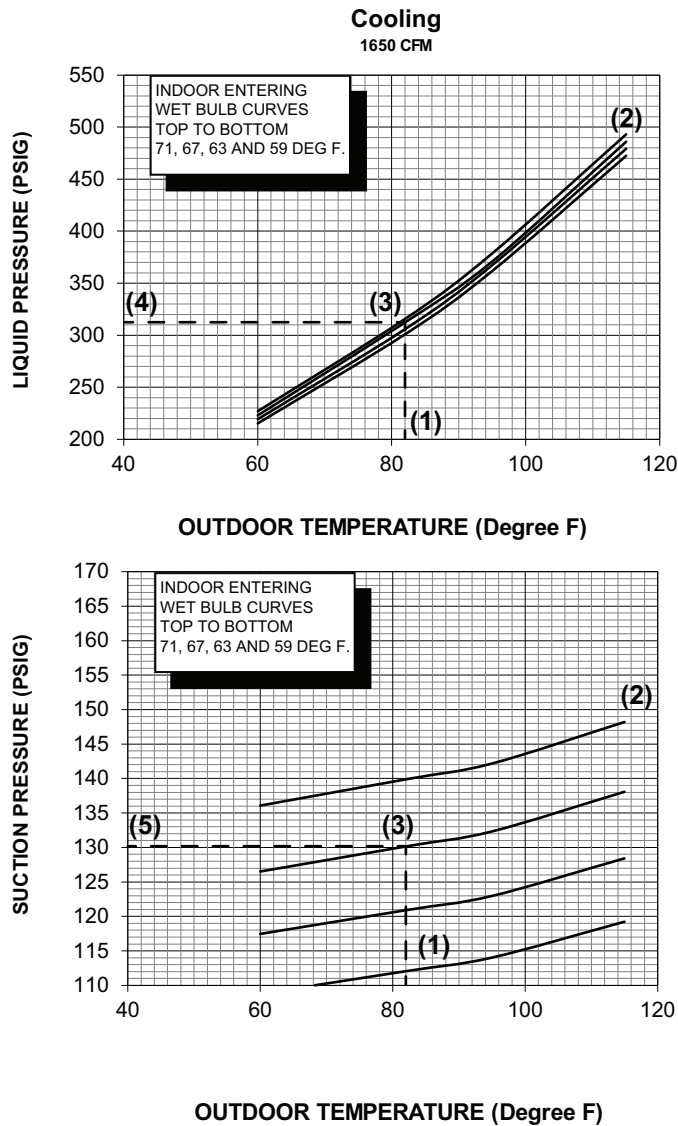

COOLING PERFORMANCE CAN BE CHECKED WHEN THE OUTDOOR TEMP IS ABOVE 65 DEG F.

TO CHECK COOLING PERFORMANCE, SELECT THE PROPER INDOOR CFM, ALLOW PRESSURES TO STABILIZE. MEASURE INDOOR WET BULB TEMPERATURE, OUTDOOR TEMPERATURE, DISCHARGE AND SUCTION PRESSURES. ON THE PLOTS LOCATE OUTDOOR TEMPERATURE (1); LOCATE INDOOR WET BULB (2); FIND INTERSECTION OF OD TEMP. & ID W.B. (3); READ DISCHARGE OR SUCTION PRESSURE IN LEFT COLUMN (4).

EXAMPLE: (1) OUTDOOR TEMP. 82 F.
 (2) INDOOR WET BULB 67 F.
 (3) AT INTERSECTION
 (4) DISCHARGE PRESSURE @ 1650 CFM IS 313 PSIG.
 (5) SUCTION PRESSURE @ 1650 CFM IS 130 PSIG.

ACTUAL:
 DISCHARGE PRESSURE SHOULD BE +/- 10 PSI OF CHART
 SUCTION PRESSURE SHOULD BE +/- 3 PSIG OF CHART

DWG.NO. A5PA3048

Figure 14. Pressure Curves for A5PA3060

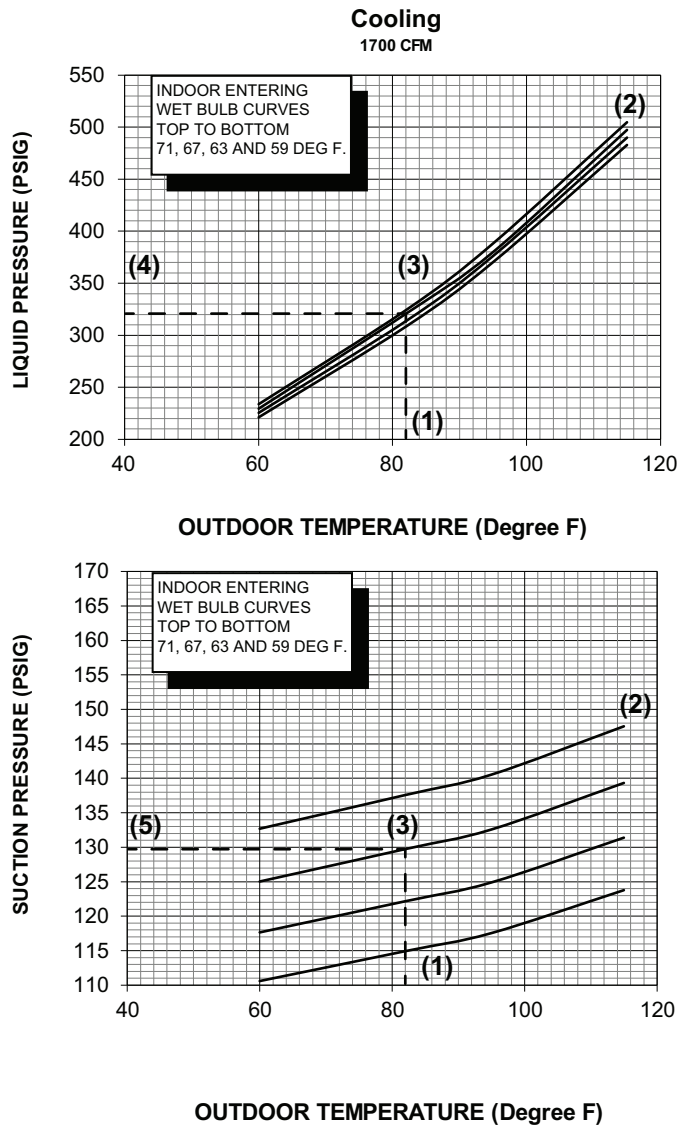

COOLING PERFORMANCE CAN BE CHECKED WHEN THE OUTDOOR TEMP IS ABOVE 65 DEG F.

TO CHECK COOLING PERFORMANCE, SELECT THE PROPER INDOOR CFM, ALLOW PRESSURES TO STABILIZE. MEASURE INDOOR WET BULB TEMPERATURE, OUTDOOR TEMPERATURE, DISCHARGE AND SUCTION PRESSURES. ON THE PLOTS LOCATE OUTDOOR TEMPERATURE (1); LOCATE INDOOR WET BULB (2); FIND INTERSECTION OF OD TEMP. & ID W.B. (3); READ DISCHARGE OR SUCTION PRESSURE IN LEFT COLUMN (4).

EXAMPLE: (1) OUTDOOR TEMP. 82 F.
 (2) INDOOR WET BULB 67 F.
 (3) AT INTERSECTION
 (4) DISCHARGE PRESSURE @ 1700 CFM IS 321 PSIG.
 (5) SUCTION PRESSURE @ 1700 CFM IS 130 PSIG.

ACTUAL:
 DISCHARGE PRESSURE SHOULD BE +/- 10 PSI OF CHART
 SUCTION PRESSURE SHOULD BE +/- 3 PSIG OF CHART

DWG.NO. A5PA3060

Indoor Fan Performance (230v)

A5PA3024		EXTERNAL STATIC PRESSURE (IN.WG) Horizontal Airflow [Cooling Down Airflow]										
Motor Speed		0.0	0.1	0.2	0.3	0.4	0.5	0.6	0.7	0.8	0.9	1
LOW	Watts	84 [85]	91 [92]	98 [98]	105 [106]	-	-	-	-	-	-	-
	CFM	873 [865]	811 [803]	754 [746]	690 [683]	-	-	-	-	-	-	-
MED-LOW ^(a)	Watts	-	114 [115]	121 [122]	128 [129]	138 [138]	-	-	-	-	-	-
	CFM	-	900 [891]	846 [838]	794 [786]	729 [722]	-	-	-	-	-	-
MED-HIGH	Watts	-	-	-	158 [159]	167 [167]	175 [176]	185 [186]	-	-	-	-
	CFM	-	-	-	890 [881]	836 [828]	777 [769]	707 [700]	-	-	-	-
HIGH	Watts	-	-	-	-	-	256 [249]	264 [258]	274 [266]	282 [276]	-	-
	CFM	-	-	-	-	-	863 [899]	818 [854]	773 [810]	731 [765]	-	-

Note: Airflow must not exceed 900 CFM due to condensate blowoff.

^(a) Factory Default Setting.

A5PA3030		EXTERNAL STATIC PRESSURE (IN.WG) Horizontal Airflow [Cooling Down Airflow]										
Motor Speed		0.0	0.1	0.2	0.3	0.4	0.5	0.6	0.7	0.8	0.9	1
LOW	Watts	126 [126]	134 [135]	142 [143]	150 [150]	158 [158]	-	-	-	-	-	-
	CFM	1051 [1041]	994 [984]	939 [930]	889 [880]	840 [831]	-	-	-	-	-	-
MED-LOW ^(a)	Watts	-	175 [176]	184 [185]	192 [193]	200 [201]	209 [210]	219 [220]	-	-	-	-
	CFM	-	1107 [1096]	1054 [1044]	1009 [999]	965 [956]	919 [910]	862 [853]	-	-	-	-
MED-HIGH	Watts	-	-	239 [240]	247 [248]	256 [258]	267 [269]	274 [276]	282 [284]	-	-	-
	CFM	-	-	1108 [1097]	1070 [1059]	1027 [1017]	975 [965]	920 [911]	875 [866]	-	-	-
HIGH	Watts	-	-	-	-	259 [260]	268 [270]	278 [279]	289 [290]	-	-	-
	CFM	-	-	-	-	1099 [1088]	1059 [1048]	1017 [1007]	968 [959]	-	-	-

Note: Airflow must not exceed 1125 CFM due to condensate blowoff.

^(a) Factory Default Setting.

A5PA3036		EXTERNAL STATIC PRESSURE (IN.WG) Horizontal Airflow [Cooling Down Airflow]										
Motor Speed		0.0	0.1	0.2	0.3	0.4	0.5	0.6	0.7	0.8	0.9	1
LOW	Watts	247 [248]	258 [260]	267 [269]	277 [279]	287 [289]	-	-	-	-	-	-
	CFM	1192 [1180]	1160 [1148]	1126 [1115]	1091 [1080]	1052 [1041]	-	-	-	-	-	-
MED-LOW ^(a)	Watts	-	352 [354]	361 [363]	372 [374]	382 [384]	392 [394]	404 [406]	416 [418]	-	-	-
	CFM	-	1272 [1259]	1243 [1231]	1214 [1202]	1186 [1174]	1154 [1142]	1116 [1105]	1072 [1061]	-	-	-
MED-HIGH	Watts	-	410 [410]	419 [419]	427 [427]	437 [437]	447 [447]	423 [423]	-	-	-	-
	CFM	-	1326 [1320]	1300 [1294]	1271 [1263]	1241 [1234]	1201 [1196]	1107 [1102]	-	-	-	-
HIGH	Watts	-	-	-	-	-	516 [519]	527 [530]	539 [542]	552 [555]	566 [569]	575 [578]
	CFM	-	-	-	-	-	1326 [1299]	1296 [1270]	1263 [1238]	1225 [1201]	1183 [1159]	1150 [1127]

Note: Airflow must not exceed 1350 CFM due to condensate blowoff.

^(a) Factory Default Setting.

Indoor Fan Performance (230v)

ASPA3042		EXTERNAL STATIC PRESSURE (IN.WG) Horizontal Airflow [Cooling Down Airflow]										
Motor Speed		0.0	0.1	0.2	0.3	0.4	0.5	0.6	0.7	0.8	0.9	1
LOW	Watts	224 [228]	233 [238]	242 [247]	252 [257]	262 [267]	-	-	-	-	-	-
	CFM	1358 [1345]	1393 [1379]	1348 [1334]	1296 [1283]	1253 [1241]	-	-	-	-	-	-
MED-LOW ^(a)	Watts	306 [312]	316 [322]	327 [333]	337 [344]	348 [354]	359 [366]	369 [377]	382 [389]	395 [403]	-	-
	CFM	1521 [1506]	1490 [1475]	1448 [1433]	1391 [1377]	1362 [1348]	1338 [1325]	1315 [1302]	1307 [1293]	1254 [1241]	-	-
MED-HIGH	Watts	-	-	-	-	455 [464]	467 [477]	477 [487]	490 [499]	503 [513]	513 [523]	-
	CFM	-	-	-	-	1529 [1514]	1491 [1476]	1467 [1453]	1425 [1411]	1385 [1371]	1345 [1331]	-
HIGH	Watts	-	-	-	-	490 [499]	502 [511]	514 [523]	527 [536]	540 [550]	554 [564]	568 [578]
	CFM	-	-	-	-	1533 [1518]	1505 [1490]	1476 [1461]	1447 [1433]	1415 [1401]	1383 [1369]	1347 [1334]

Note: Airflow must not exceed 1575 CFM due to condensate blowoff.

^(a) Factory Default Setting.

ASPA3048		EXTERNAL STATIC PRESSURE (IN.WG) Horizontal Airflow [Cooling Down Airflow]										
Motor Speed		0.0	0.1	0.2	0.3	0.4	0.5	0.6	0.7	0.8	0.9	1
LOW	Watts	302 [308]	313 [320]	324 [330]	332 [339]	346 [352]	-	-	-	-	-	-
	CFM	1583 [1567]	1542 [1526]	1502 [1487]	1460 [1445]	1415 [1401]	-	-	-	-	-	-
MED-LOW ^(a)	Watts	414 [422]	426 [434]	436 [444]	448 [457]	459 [468]	471 [480]	483 [493]	495 [505]	510 [520]	-	-
	CFM	1763 [1745]	1723 [1706]	1689 [1672]	1648 [1632]	1609 [1593]	1568 [1552]	1527 [1512]	1488 [1473]	1447 [1433]	-	-
MED-HIGH	Watts	-	577 [589]	591 [603]	604 [616]	617 [629]	631 [644]	643 [656]	655 [668]	599 [611]	-	-
	CFM	-	1786 [1768]	1757 [1739]	1729 [1712]	1700 [1683]	1675 [1658]	1648 [1632]	1624 [1608]	1504 [1489]	-	-
HIGH	Watts	-	-	-	-	-	613 [625]	631 [644]	643 [656]	647 [660]	611 [623]	-
	CFM	-	-	-	-	-	1769 [1751]	1728 [1711]	1688 [1671]	1652 [1635]	1545 [1530]	-

Note: Airflow must not exceed 1800 CFM due to condensate blowoff.

^(a) Factory Default Setting.

ASPA3060		EXTERNAL STATIC PRESSURE (IN.WG) Horizontal Airflow [Cooling Down Airflow]										
Motor Speed		0.0	0.1	0.2	0.3	0.4	0.5	0.6	0.7	0.8	0.9	1
LOW	Watts	515 [524]	523 [533]	533 [545]	544 [558]	-	-	-	-	-	-	-
	CFM	1857 [1831]	1831 [1802]	1800 [1765]	1766 [1728]	-	-	-	-	-	-	-
MED-LOW ^(a)	Watts	594 [611]	609 [627]	624 [642]	639 [658]	653 [672]	667 [686]	681 [701]	695 [715]	709 [730]	-	-
	CFM	2031 [2003]	2003 [1975]	1974 [1946]	1940 [1913]	1907 [1880]	1874 [1848]	1837 [1811]	1805 [1780]	1771 [1746]	-	-
MED-HIGH	Watts	749 [770]	759 [781]	769 [790]	779 [804]	788 [819]	803 [832]	816 [845]	830 [858]	845 [872]	860 [887]	-
	CFM	2083 [2054]	2058 [2030]	2032 [2010]	2003 [1976]	1974 [1946]	1943 [1911]	1911 [1879]	1877 [1848]	1843 [1817]	1807 [1781]	-
HIGH	Watts	900 [940]	910 [936]	921 [937]	932 [948]	941 [962]	956 [975]	969 [990]	983 [992]	997 [987]	1010 [985]	-
	CFM	2201 [2201]	2177 [2151]	2152 [2120]	2127 [2095]	2105 [2066]	2071 [2033]	2041 [1999]	2009 [1937]	1975 [1921]	1940 [1871]	-

Note: Airflow must not exceed 2250 CFM due to condensate blowoff.

^(a) Factory Default Setting.

Refrigerant Circuits

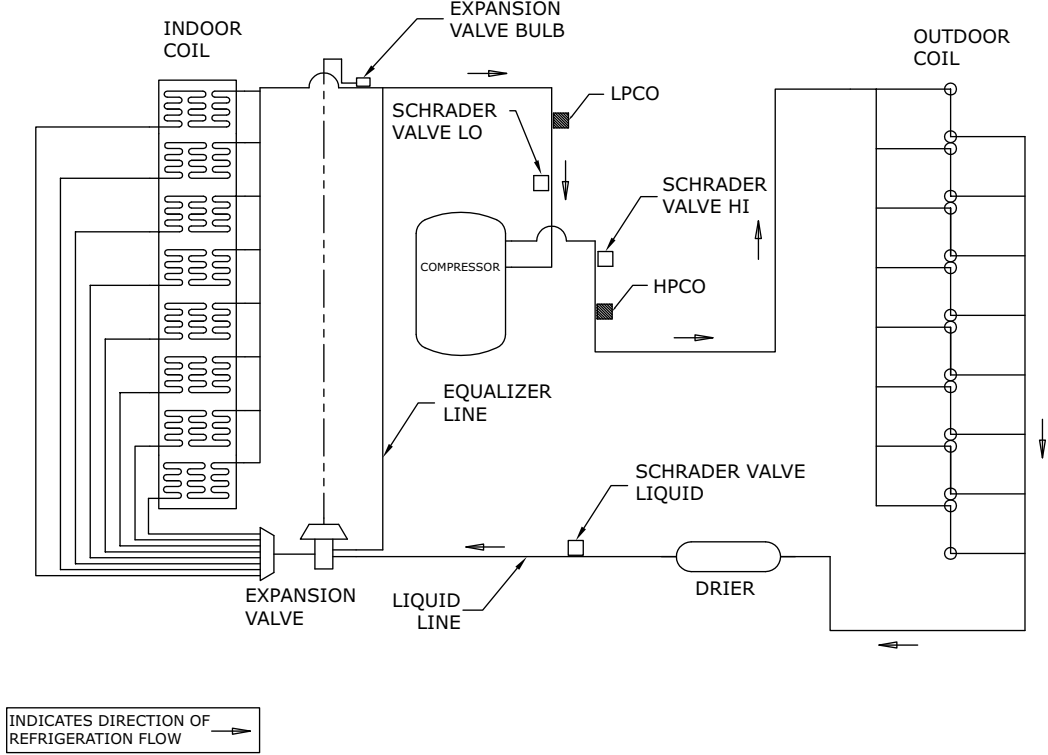

Troubleshooting Chart

P-PRIMARY CAUSES / S-SECONDARY CAUSES

SYSTEM FAULTS	Power Supply	High Voltage Wiring	Compr. IOL	Run Capacitor	Start capacitor	Start Relay	Contactors Contacts	Low Voltage Wiring	Control Transformer	Contactor Coil	Low Voltage Fuse	Stuck Compressor	Ineffecient Compressor	Refrigerant Undercharge	Refrigerant Overcharge	Excessive Evap. Load	Noncondensables	Restricted O.D. Airflow	O.D. Air Recirculation	TXV Stuck Open	Low Superheat	High Superheat	Restricted I.D. Airflow	Ref. Circuit Restrictions	Mitigation System
REFRIGERANT CIRCUIT																									
Liquid Pressure too High															P		S	P	S					S	
Liquid Pressure too Low													S	P						S		S		S	
Suction Pressure too High													S		P	P				S	S				
Suction Pressure too Low														S								S	P	S	
Liquid Refrigerant Floodback (TXV System)																				S	S		P		
I.D. Coil Frosting														P							S		P	S	
Compressor Runs Inadequate or No Cooling													S	P		P	S	S	S			S	P	S	
ELECTRICAL																									
Compressor & O.D. Fan Do Not Start	P	P					S	S	P	P	P														P(a)
Compressor will not Start but O.D. Fan Runs		P	S	P	P	P						S													
O.D. Fan will Not Start		P		P																					
Compressor Hums but will Not Start		P		P	P	P	S					S													
Compressor Cycles on IOL		P	S	P	P	P	S					P	S	P	S	S	S	S	S			S		S	
I.D. Blower willnot Start	P	S						S	P	P															

(a) See, [Verification of Mitigation Actions](#), p. 26



Notes

Important Product Information

Packaged Unit Serial Number _____

Packaged Unit Model Number _____

Date of Installation _____

Dealer _____

Service Information

Call your installing dealer if the unit is inoperative. Before you call, always check the following to be sure service is required:

1. Be sure the main switch that supplies power to the unit is in the ON position.
2. Replace any burned-out fuses or reset circuit breakers.
3. Be sure the thermostat is properly set.

Service Phone _____

About Trane and American Standard Heating and Air Conditioning

Trane and American Standard create comfortable, energy efficient indoor environments for residential applications. For more information, please visit www.trane.com or www.americanstandardair.com.



The AHRI Certified mark indicates company participation in the AHRI Certification program. For verification of individual certified products, go to ahridirectory.org.

The manufacturer has a policy of continuous data improvement and it reserves the right to change design and specifications without notice. We are committed to using environmentally conscious print practices.