

Installer's Guide

Defrost Coil Sensor Kit

KIT19795

(Used on all HP models except Side Discharge models)

ALL phases of this installation must comply with NATIONAL, STATE AND LOCAL CODES

IMPORTANT — This Document is **customer property** and is to remain with this unit. Please return to service information pack upon completion of work.

Safety Considerations

⚠ WARNING

Only qualified personnel should install and service the equipment. The installation, starting up, and servicing of heating, ventilating, and air-conditioning equipment can be hazardous and requires specific knowledge and training. Improperly installed, adjusted or altered equipment by an unqualified person could result in death or serious injury. When working on the equipment, observe all precautions in the literature and on the tags, stickers, and labels that are attached to the equipment.

⚠ WARNING

HAZARDOUS VOLTAGE!

Failure to follow this Warning could result in property damage, severe personal injury, or death. Disconnect all electric power, including remote disconnects before servicing. Follow proper lockout/tagout procedures to ensure the power cannot be inadvertently energized.

Inspection

1. Unpack all components of the kit.
2. Check carefully for any shipping damage. If any damage is found, this must be reported immediately and a claim made against the transportation company.
3. Check to be sure all components are in the package. Any missing components should be reported to your supplier at once and replaced with authorized components only.

General Information

It is normal to have variations in feeding of the outdoor refrigerant circuits. In some applications it is normal to see this in the form of frost banding. The recommended solution in these situations is to relocate the coil sensor to another circuit.

Before relocating the coil sensor, verify the following:

- refrigerant charge
- indoor air performance and
- air circulation around the outdoor unit

Steps in this document will aid in the identification of which circuit might be best in the relocation of the coil sensor.

Coil Sensor Kit Contents:

Item	Qty.	Description
1	1	3/8" Coil Clip
2	1	Installer's Guide

Installation:

1. To remove the clip, firmly hold sensor base with both hands. Firmly press with both thumbs on the open end of the clip and push towards the sensor bulb.
2. To replace with the 3/8 clip, line up the clip notches to the sensor base and follow steps in reverse.

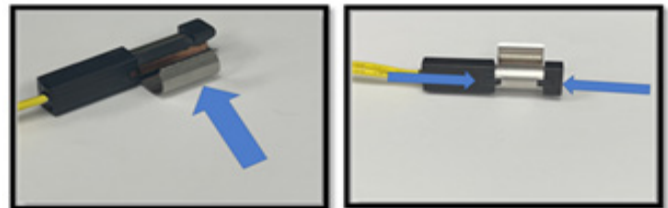

Use the steps in the troubleshooting flowchart on the next page to identify the new placement of the coil sensor.

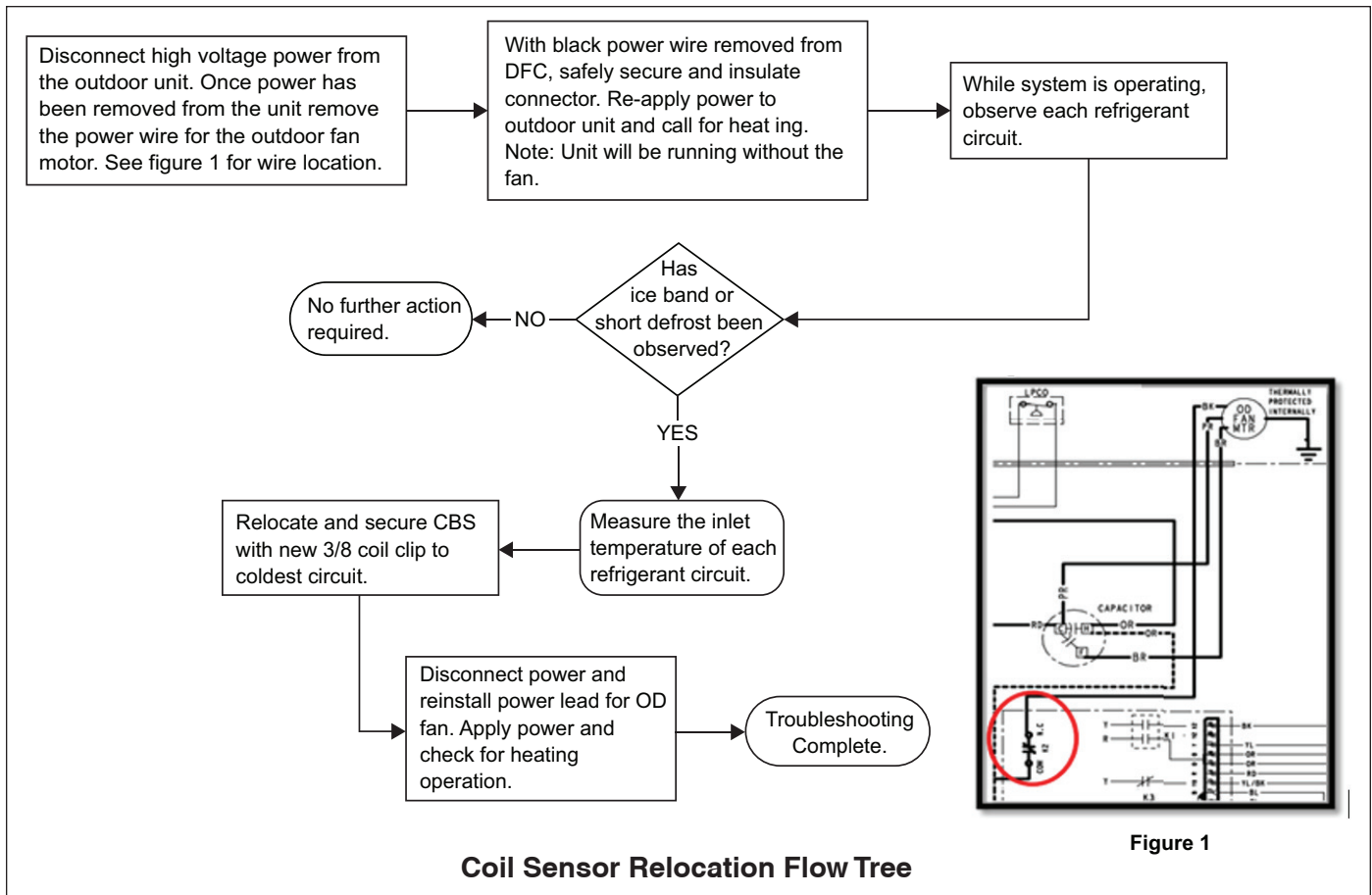

Below are before and after examples of sensors that have been relocated on Trane, American Standard and Runtru heat pumps. These pictures are for reference only. Follow troubleshooting tree to find best location for coil sensor. If ice banding is found on side discharge models, contact your local distributor for further troubleshooting assistance.

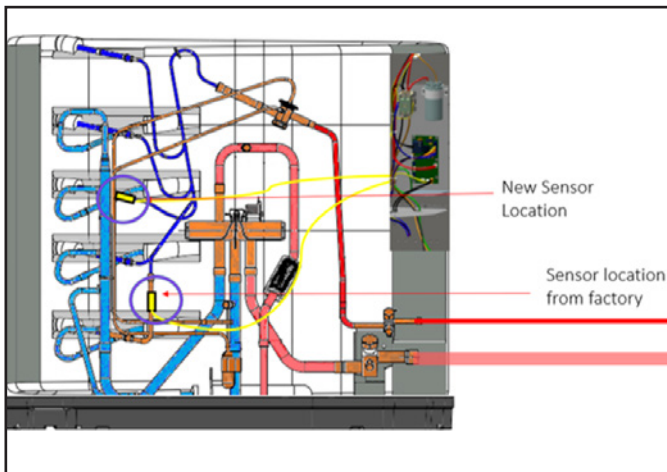

Trane/ American Standard

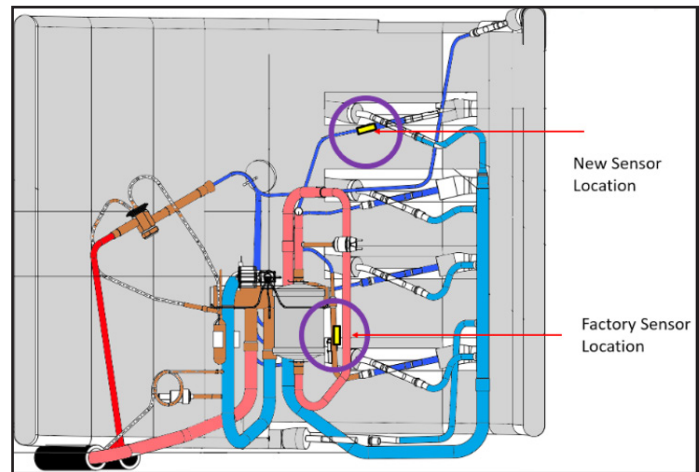

RunTru/ Tyler made Ameristar

About Trane and American Standard Heating and Air Conditioning

Trane and American Standard create comfortable, energy efficient indoor environments for residential applications. For more information, please visit www.trane.com or www.americanstandardair.com

The manufacturer has a policy of continuous data improvement and it reserves the right to change design and specifications without notice. We are committed to using environmentally conscious print practices.

Representative-only illustrations included in this document.

18-HH40D1-1A-EN 28 Mar 2022

Supersedes (New)

© 2022