

INSTALLER'S GUIDE

18-HE42D6-3B-EN

ALL phases of this installation must comply with NATIONAL, STATE, AND LOCAL CODES

Model	Used With:	Mounted on:	Roofcurb Adaptors
	TC, *WC*, *YC*, *DC**		
BAYADAP050	018-36	BAYCURB030,38	
BAYADAP051	018-36	BAYCURB033	
BAYADAP052	042-60	BAYCURB030,38	
BAYADAP053	042-60	BAYCURB033	
BAYADAP054	042-60	BAYCURB034	

*Note: * indicates an alpha character.*

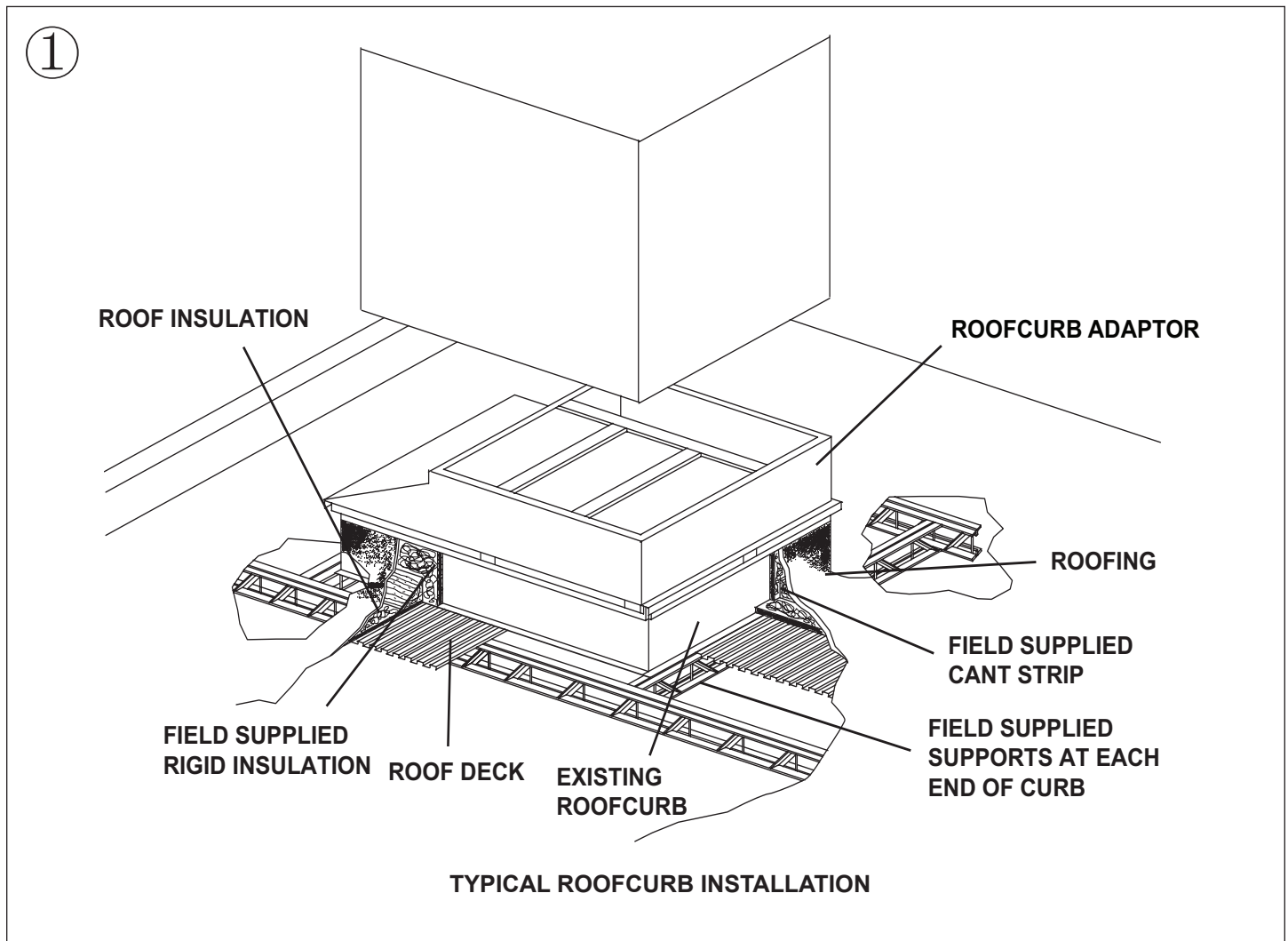

INSTALLER'S GUIDE

This booklet covers the roofcurb adaptors for the 1 1/2 thru 5 ton models only Single Package Units. These instructions are organized for an easy step-by-step procedure. The curb adaptors are shipped fully assembled and are insulated internally. For instructions related to the Single Package HVAC unit, refer to the instructions packaged with that unit.

General – Locations and Recommendations

These instructions do not cover all variations in systems or provide for every possible contingency to be met in connection with the installation. Should further information be desired or should particular problems arise which are not covered sufficiently for the purchaser's purposes, the matter should be referred to the manufacturer.

Check for transportation damage after the packaging is removed. Report promptly, to the carrier, any damage found.

These curb adaptors are designed specifically to transition packaged units to existing perimeter curbs (not utility curbs) for older rooftop units. See Table 1, page 3. Questions regarding the transition of packaged units to existing utility curbs for older rooftop units should be referred to the manufacturer.

Existing curb dimensions: These curb adaptors are designed to fit the existing unit curbs. It is the responsibility of the installer to be sure that the dimensions shown in this booklet for the existing curb, match the dimensions of the actual curb on the job site.

Curb Adaptor static pressure loss: All curb adaptors will increase the total system external static pressure and must be included when calculating the new unit's requirements and sizing.

Duct considerations: The new curb adaptor is designed with an integral duct system which transitions the duct openings in the top of the curb adaptor to the duct openings in the top of the existing curb. No additional duct work or transitions should be required.

1. Follow all local and other applicable building codes when installing the curb adaptor system.
2. Adequate support must be provided beneath the existing curb for the entire length of the curb. The total weight of the unit, existing curb, curb adaptor and duct, plus any accessories, must be considered when selecting and placing the unit and curb adaptor on the roof.
3. Be sure the location of the curb adaptor will allow needed service clearance around unit when the unit is in place (as illustrated)
4. Do not locate the curb adaptor near exhaust vents or other sources of contaminated air that could enter the unit air inlets. Although the unit is waterproof, guard against water run off from higher overhanging structures.
5. The top of the curb adaptor must be installed flat and level – (maximum pitch of ¼" per foot). If the pitch is greater than ¼" per foot, contractor must make adjustments to provide an adequate pitch.

Instructions:

6. Remove the electric, gas and duct connections directly attached to the existing HVAC unit.
7. Carefully lift the existing unit from the existing curb and roof. Ensure that extra fasteners holding the unit to the curb are removed. The unit should be discarded in a manner consistent with local codes.
8. Remove any / all gasketing from the top perimeter of the existing curb. Re-install new gasketing, provided with the curb adaptor, around the top perimeter and duct openings of existing curb.
9. Using proper, acceptable, and safe lifting methods, hoist the curb adaptor to the roof and carefully set in place on top of the existing curb. Be sure the curb adaptor is oriented properly so that the duct openings align properly. (See detailed drawings following.) Secure the curb adaptor to the existing curb with sheet metal screws.
10. Install the gasketing, provided with curb adaptor, around the top perimeter and duct openings of the curb adaptor. Carefully set HVAC unit in place.
11. Reconnect the electrical and gas lines to the HVAC unit.

REQUIRED CLEARANCE FOR UNIT INSTALLATION AND ROOF PENETRATION HOLE SIZE REQUIRED

②

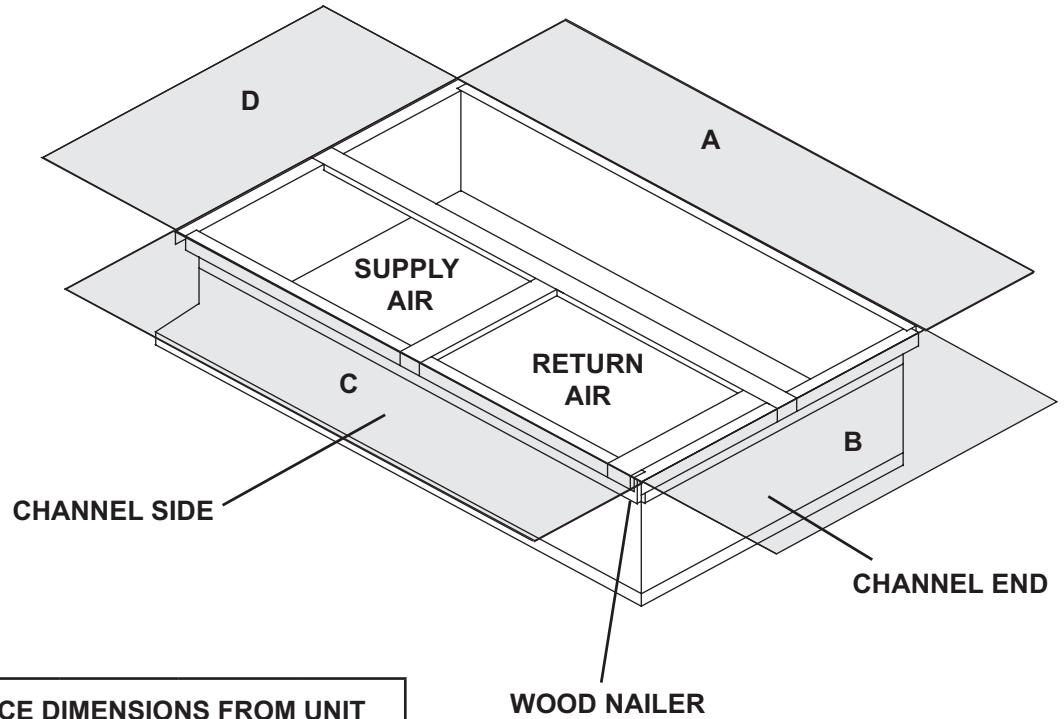

SERVICE CLEARANCE DIMENSIONS FROM UNIT

UNIT	A	B	C	D
****018-36	42"	36"*	12"***	42"
****042-60	42"	36"*	12"***	42"

* 42" WITH DOWN ECONOMIZER BAYECON101,102

** 24" WITH MOTORIZED DAMPER BAYDMPR101,102

TABLE 1

EXISTING CURB	NEW UNIT *TC/*WC/*YC/*DC**	USE BAYADAP0**
BAYCURB030,38	018-036	50
BAYCURB030,38	042-060	52
BAYCURB033	018-036	51
BAYCURB033	042-060	53
BAYCURB034	042-060	54

INSTALLER'S GUIDE

BAYADAP050 CURB ADAPTOR FOR ***018-36 TO EXISTING BAYCURB030 OR BAYCURB038

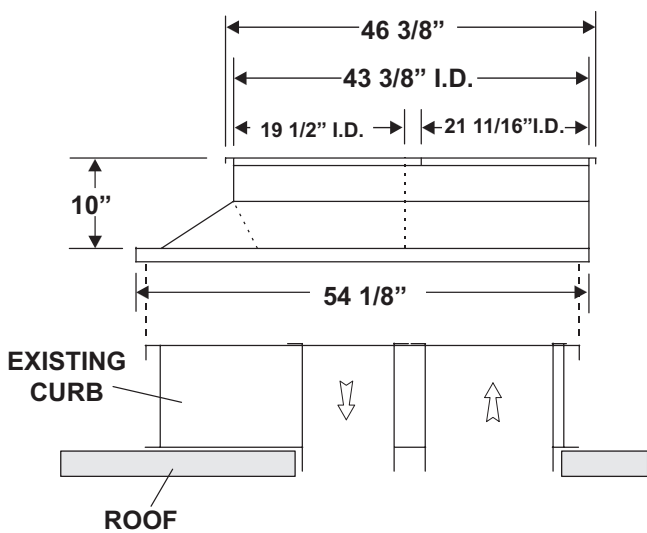
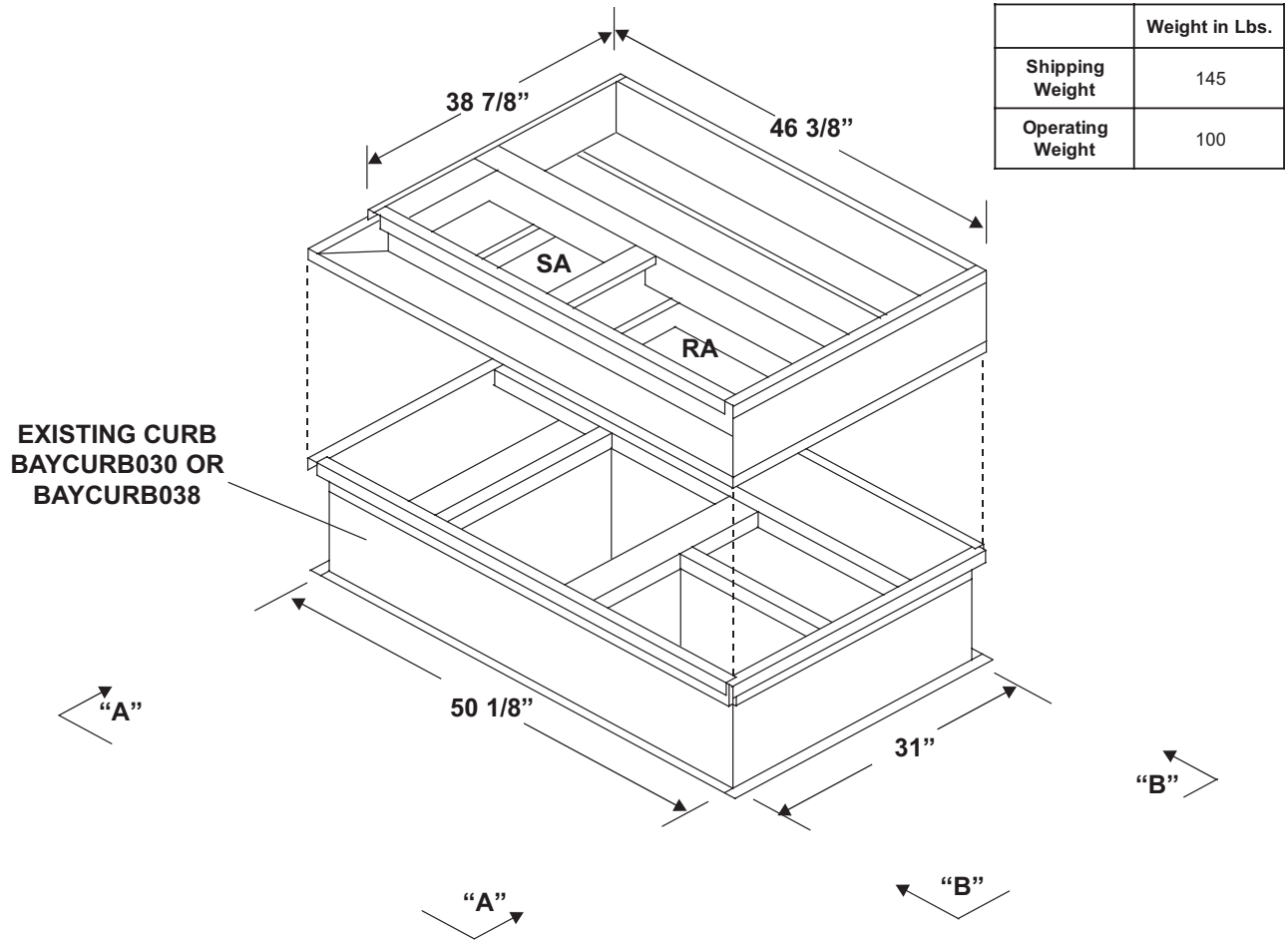

VIEW "A"-"A"

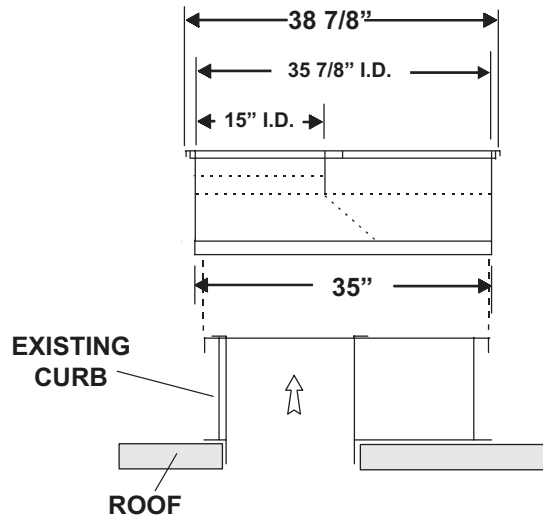

VIEW "B"-"B"

* All 15 digit model numbers are starting with a number and YCC, YCX, TCC, TCX, WCC, WCX YCY, TCY, WCY, DCY, YCZ, WCZ, and DCZ

BAYADAP051 CURB ADAPTOR FOR ***018-36 TO EXISTING BAYCURB033

	Weight in Lbs.
Shipping Weight	145
Operating Weight	100

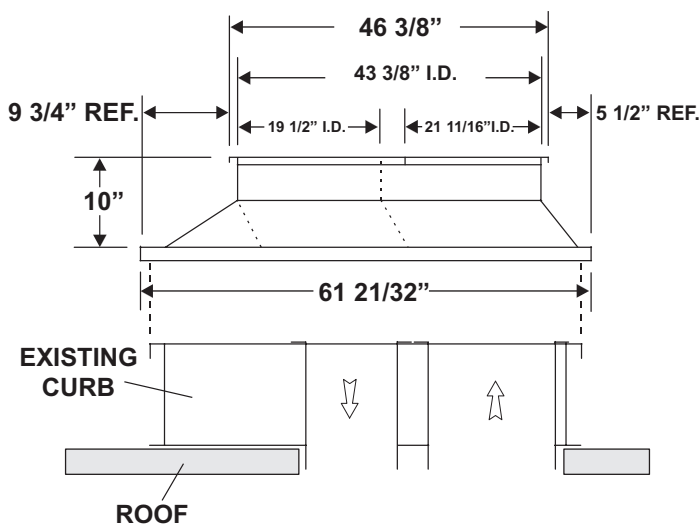
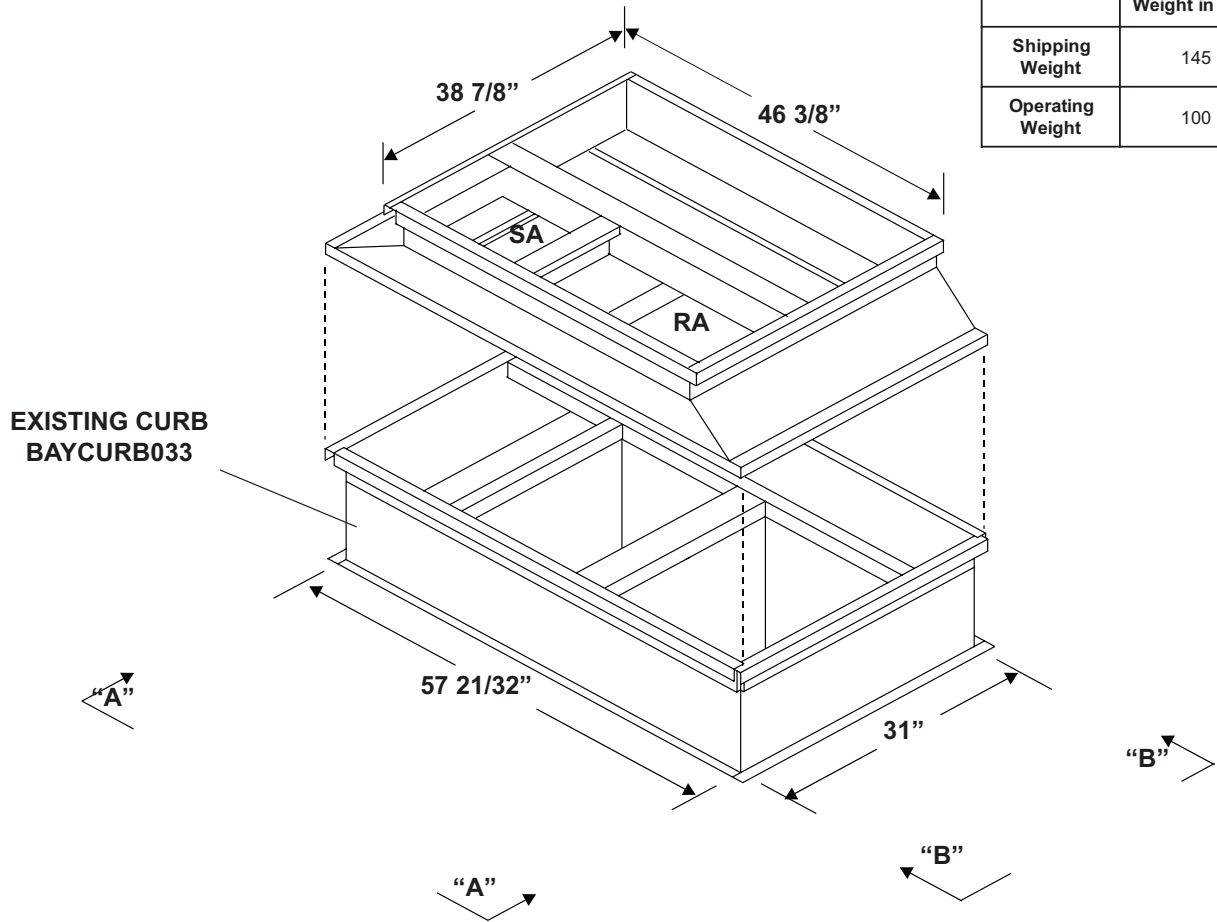

VIEW "A"-"A"

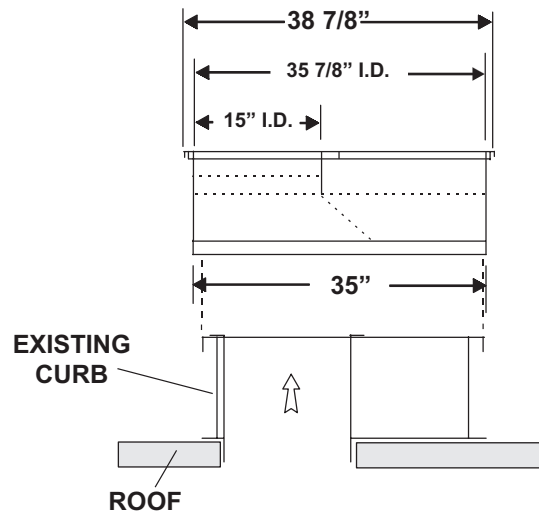

VIEW "B"-"B"

* All 15 digit model numbers are starting with a number and YCC, YCX, TCC, TCX, WCC, WCX YCY, TCY, WCY, DCY, YCZ, WCZ, and DCZ

INSTALLER'S GUIDE

BAYADAP052 CURB ADAPTOR FOR *****042-60 TO EXISTING BAYCURB030 OR BAYCURB038

	Weight in Lbs.
Shipping Weight	155
Operating Weight	110

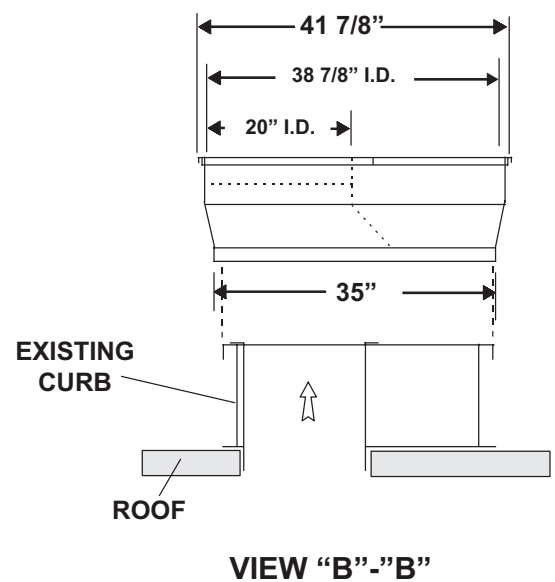
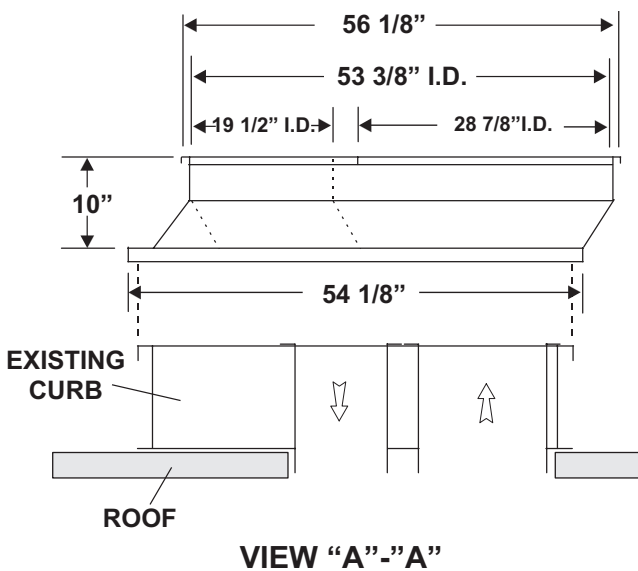
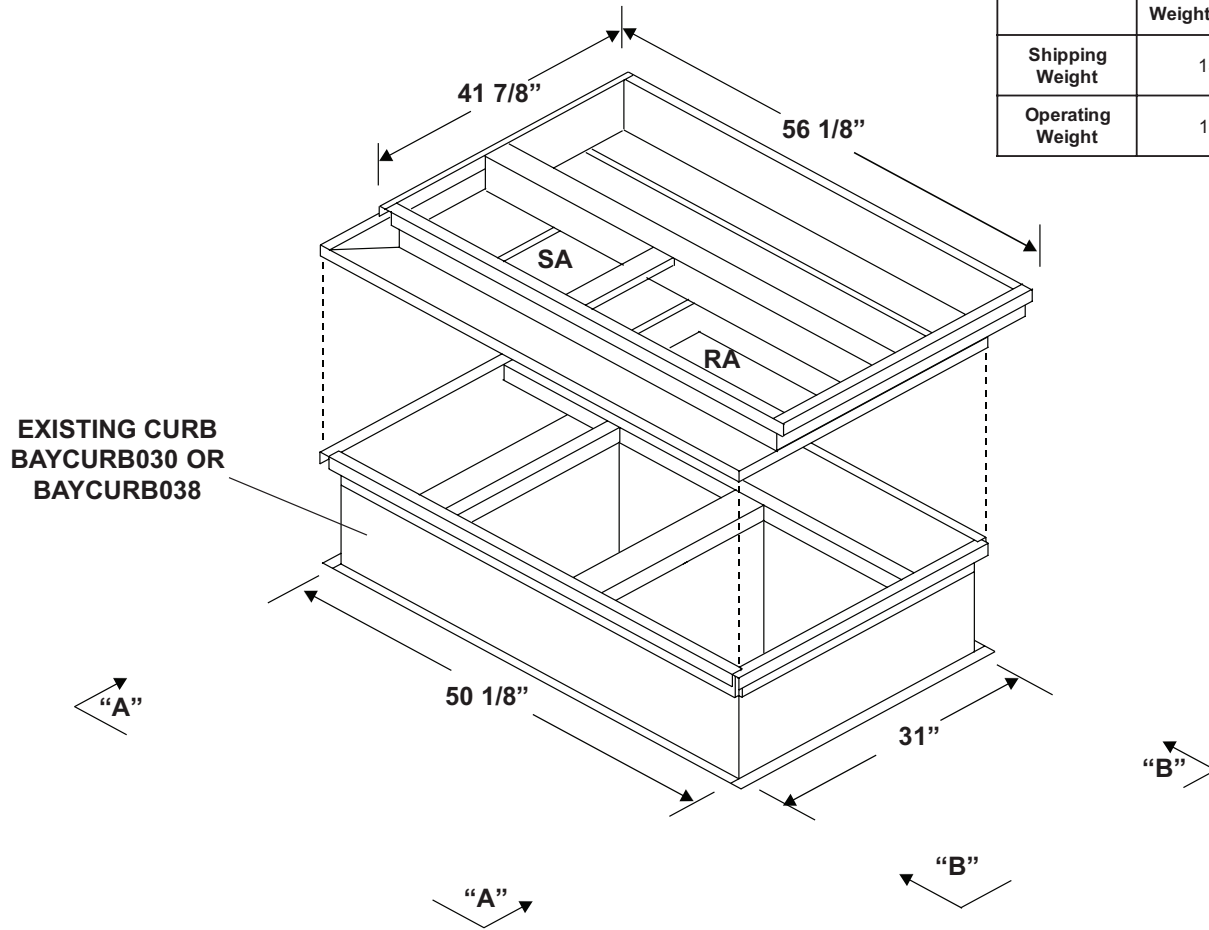

* All 15 digit model numbers are starting with a number and YCC, YCX, TCC, TCX, WCC, WCX YCY, TCY, WCY, DCY, YCZ, WCZ, and DCZ

BAYADAP053 CURB ADAPTOR FOR *****042-60 TO EXISTING BAYCURB033

	Weight in Lbs.
Shipping Weight	155
Operating Weight	110

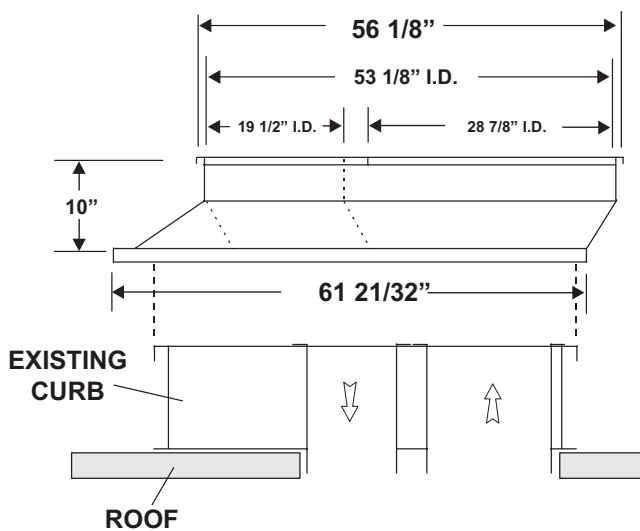
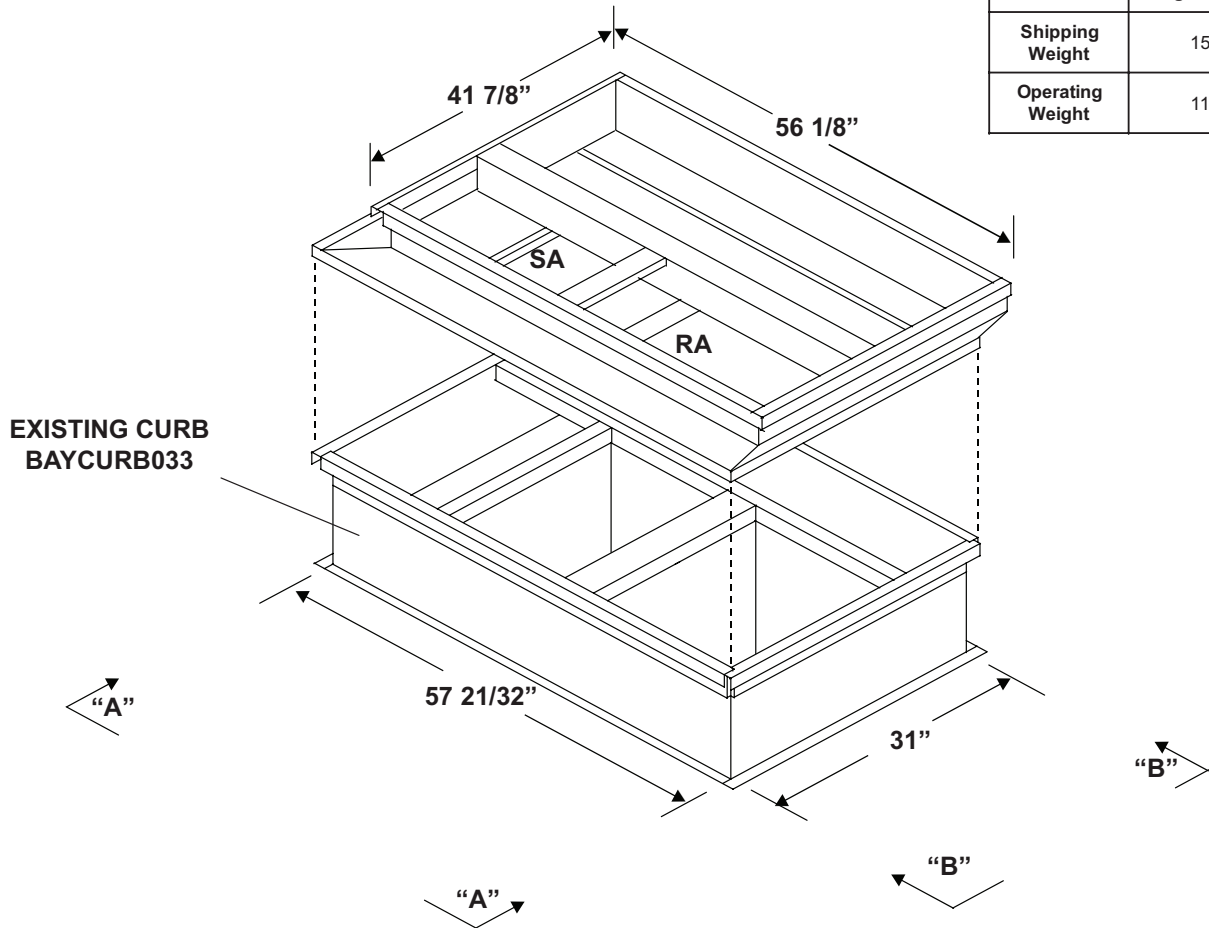

VIEW "A"-"A"

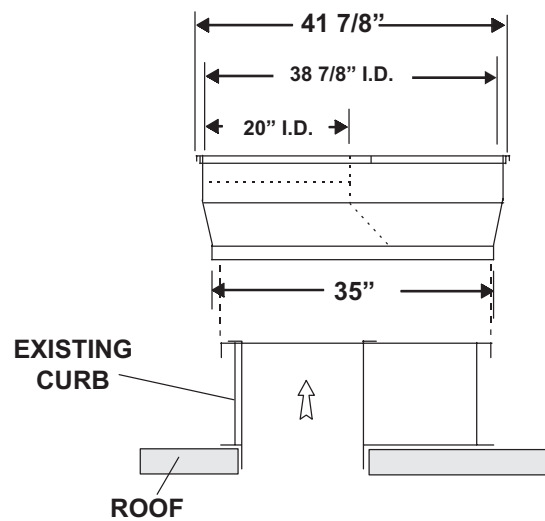

VIEW "B"-"B"

* All 15 digit model numbers are starting with a number and YCC, YCX, TCC, TCX, WCC, WCX YCY, TCY, WCY, DCY, YCZ, WCZ, and DCZ

INSTALLER'S GUIDE

BAYADAP054 CURB ADAPTOR FOR *****042-60 TO EXISTING BAYCURB034

	Weight in Lbs.
Shipping Weight	155
Operating Weight	110

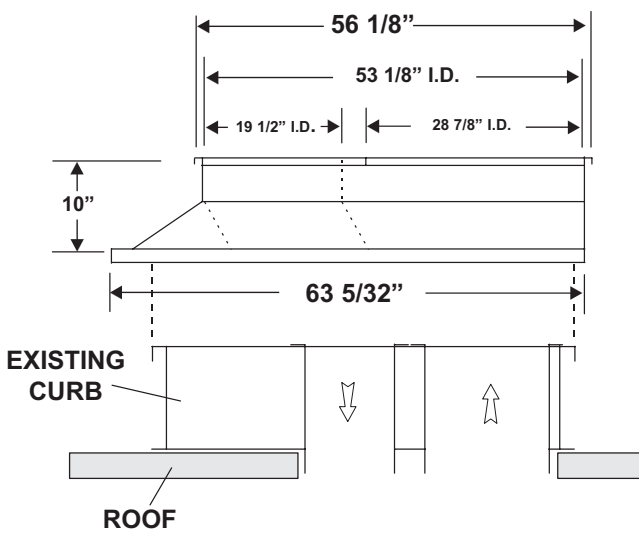
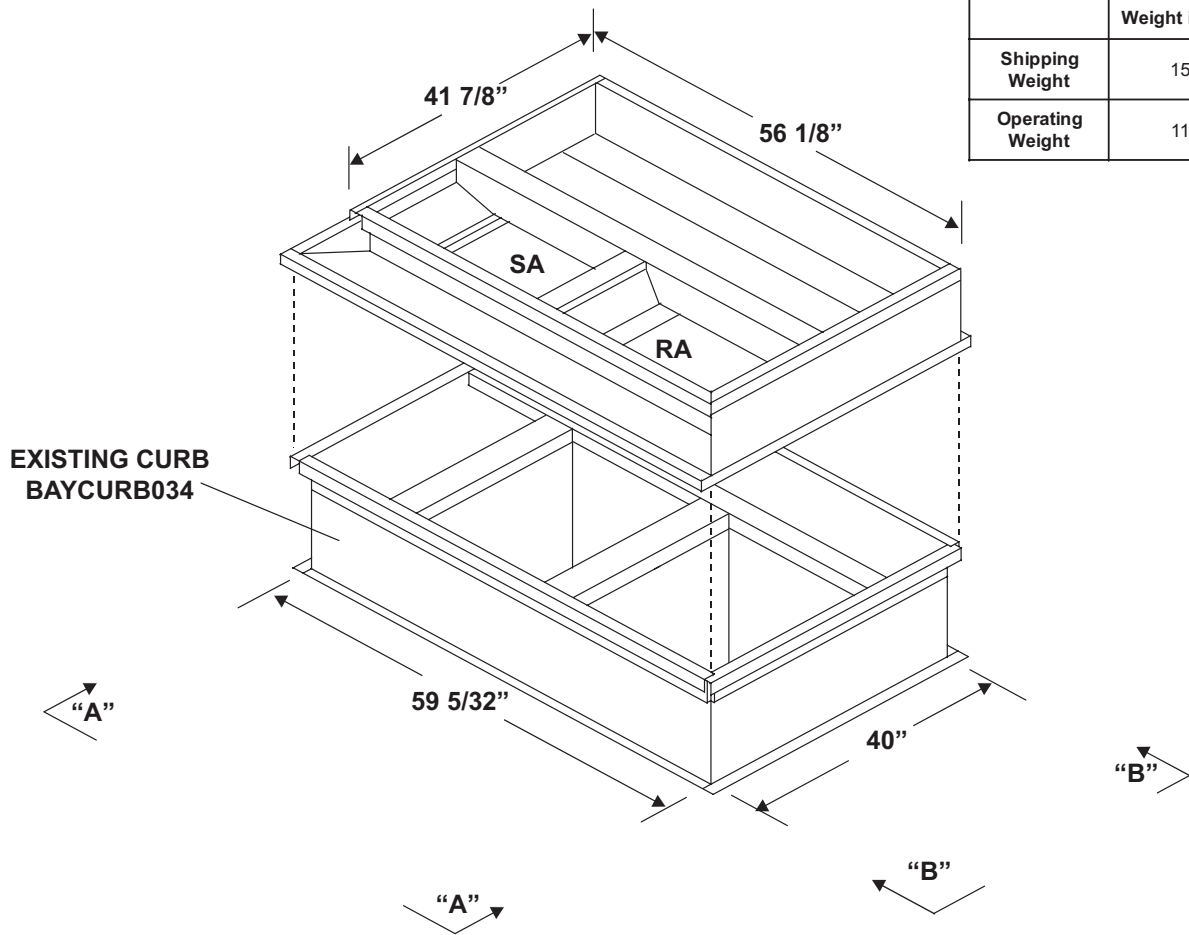

VIEW "A"-"A"

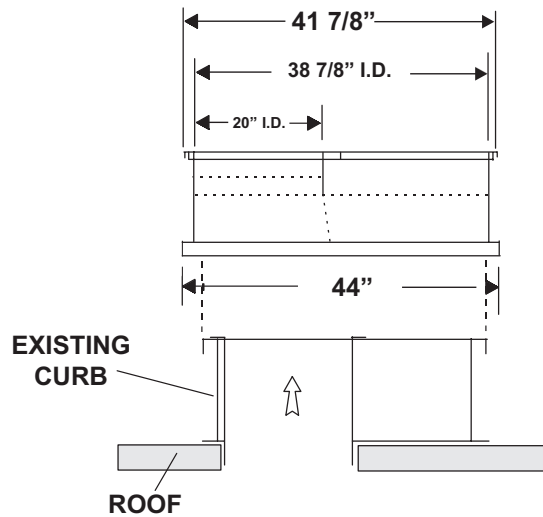

VIEW "B"-"B"

* All 15 digit model numbers are starting with a number and YCC, YCX, TCC, TCX, WCC, WCX YCY, TCY, WCY, DCY, YCZ, WCZ, and DCZ

ROOF MOUNTING CURB (CONT.) P.V.C. RUBBER GASKET POSITION ON BAYCURB FOR UNIT PLACEMENT

1. Install the insulated deck pans (if required) on the curb before placing the 1-1/2" x 1/2" P.V.C. rubber tape (gasket) on mounting curb as illustrated. P.V.C. tape to be applied to curb as shown just prior to setting unit on the mounting curb.
2. P.V.C. rubber tape (supplied with curb) must be applied in continuous strips of overlapped 1" minimum for complete watertight seal.

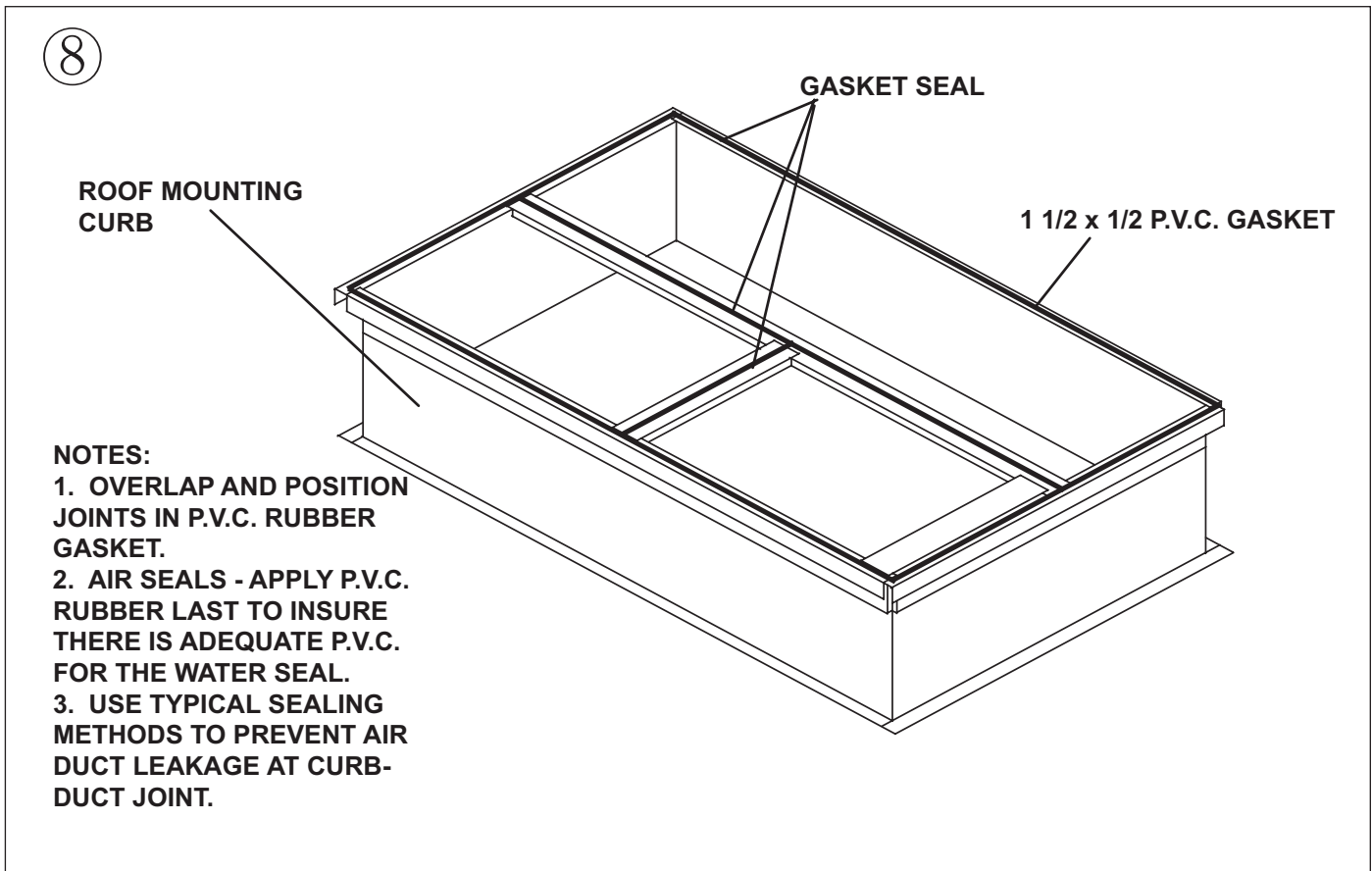

About Trane and American Standard Heating and Air Conditioning

Trane and American Standard create comfortable, energy efficient indoor environments for residential applications. For more information, please visit www.trane.com or www.americanstandardair.com

The manufacturer has a policy of continuous data improvement and it reserves the right to change design and specifications without notice. We are committed to using environmentally conscious print practices.

18-HE42D6-3B-EN 14 Jul 2023

Supersedes 18-HE42D6-3A-EN (July 2020)

© 2023