

Installer's Guide

Down Discharge Economizer and Rain Hood

Model:

BAYECON107A
BAYECON108A
BAYRLAY006B

Used with:

*DCZ, *WCZ, *Y CZ *018-036
*DCZ, *WCZ, *Y CZ *042-060
(Relay required in *WC* Units)

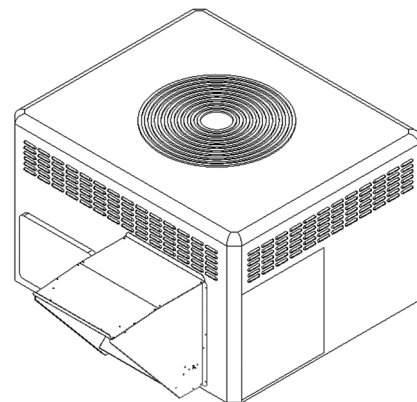

Note: "Graphics in this document are for representation only. Actual model may differ in appearance."

*Note: * indicates an alphanumeric character.*

⚠ SAFETY WARNING

Only qualified personnel should install and service the equipment. The installation, starting up, and servicing of heating, ventilating, and air-conditioning equipment can be hazardous and requires specific knowledge and training. Improperly installed, adjusted or altered equipment by an unqualified person could result in death or serious injury. When working on the equipment, observe all precautions in the literature and on the tags, stickers, and labels that are attached to the equipment.

⚠ WARNING: HAZARDOUS VOLTAGE - DISCONNECT POWER BEFORE SERVICING

ALL phases of this installation must comply with NATIONAL, STATE AND LOCAL CODES

IMPORTANT — This Document is **customer property** and is to remain with this unit. Please return to service information pack upon completion of work.

General

The economizer is a multi-damper design. It is installed in the return air stream and is connected to the unit low voltage supply through wire leads. The economizer is fully accessible through the Coil access panel.

Important: After the Economizer installation you must install an air filter rack ordered separately. Use:

BAYFLTR101 for *WCZ, *YCZ, *DCZ *024-036
BAYFLTR201 for *WCZ, *YCZ, *DCZ *042-060.

When the economizer is installed in *WCZ and *DCZ models, relay accessory kit BAYRLAY006B is required. Refer to the appropriate hookup diagram, depending on model number of unit to make your relay wiring connections in the Control Box.

IMPORTANT: In order to maintain a specific minimum fresh air cfm during each mode of operation, you must order and install a BAYOSAC001 (outside air control) accessory.

Identify Economizer Kit Contents

Refer to Figures 1 and 2 to identify the kit contents.

Inspect Contents

You must report damage and make claims to the transportation company immediately. Report missing parts to your supplier immediately and replace with authorized parts only.

⚠ WARNING

ELECTRIC SHOCK HAZARD

Open and lock out all unit disconnects prior to accessory installation or unit maintenance, to prevent injury or death from electrical shock or contact with moving parts.

⚠ WARNING

SAFETY HAZARD

Do not remove end covers from economizer actuator; the spring-return assembly may release and cause personal injury.

⚠ CAUTION

Use care when inserting the economizer in the return air compartment, to prevent damaging the foil faced insulation.

Install Economizer Kit

1. Remove Power

Disconnect and verify that power is off.

2. Remove Access Panels

Remove these four (4) access panels (see Figure 3):

- Control/Heat access panel
- Blower access panel
- Coil access panel
- Downflow Return Air panel

3. BAYRLAY006B Installation (Required for *WCZ and *DCZ units only, for *YCZ units skip to step 4)

1. Remove wire harness that came attached to the BAYECON Logic Module being installed.

IMPORTANT: Do NOT remove the resistors from the Logic Module. Also, Do NOT remove the YL and YL/BK wires connected to SO and + on the Logic Module

2. Locate the ICMC Board in the upper left hand corner of the unit control box and the DFC board in the upper center of the unit control box. See Figure 8.
3. Using the existing holes in the back of the unit control box, mount the relay bracket assembly using the 2 screws supplied with the BAYRLAY006B Kit. See Figure 8.
4. Route the BAYRLAY006B wire harness attached to the relays to the logic module as shown in Figure 11.
5. Connect the BAYRLAY006B to the economizer Logic Module and make the field connections as shown in the appropriate hookup diagram depending on model number of unit.

4. Install Economizer Assembly

NOTE: You must install the filter rack per the instructions provided with the filter rack after you install the economizer.

1. The economizer ships with the return air damper folded up to allow the assembly to fit through the Coil opening in the side of the unit. Insert the economizer assembly into the unit through the Coil access panel opening. See Figure 4.
2. Swing the return air damper section down so that it rests on the bottom of the unit. The economizer will sit completely over the return air opening in the bottom of the unit. See Figure 5.

A gear and (1) E-Clip will be provided with each of the economizers, that will need to be installed after the above process has been completed.

3. Insert a screw through the pre-punched hole in the side flange of the return air damper and into the mating hole in the economizer assembly and tighten. See Figure 5.
4. Insert 2 screws through the holes in the front face of the unit and into the matching attachment holes in the economizer assembly. See Figure 6.

5. Install Rain Hood Assembly

1. Locate the rainhood assembly, which includes the relief damper and the mist eliminator. The back of the hood side mating flanges need to be gasketed (gaskets included in kit). Loosen the right two (2) screws on the unit's top sealing flange above the economizer. See Figure 7.
2. Slide the top flange of the hood underneath the unit's top sealing flange. Drive two self tapping screws into the keyhole openings on the side flanges of the hood. Tighten the two (2) screws on the top sealing flange and the screws on the hood side flanges. See Figures 7 and 9.

6. Mount Mixed Air Sensor

1. Mount the Mixed Air sensor (with wiring) to the left Blower partition using two sheetmetal screws. See Figure 10. The male tabs on the Yellow and Yellow/Black wires will connect to the Economizer wiring harness in a later step.
2. Enthalpy Sensor If used, install this option at this time per instructions provided in the sensor kit.

7. Route Main Wiring

1. From the Economizer assembly, pass the wire harness through the coil grommet. See Figure 11 (view A). Continue routing the harness behind the Compressor compartment and into the Blower compartment.
2. Continue routing the remaining harness through the grommet in the Control Box partition and into the Control Box.

8. Complete Installation (*WCZ, *DCZ, *YCZ)

1. In the Control Box, locate the ICMC Board in the upper left hand corner of the Control Box. Find the YL/RD and YL wires in the 12 pin connector. Leaving enough length of these wires so that the ends going to the ICMC Board can be stripped, cut these wires in two. Strip the cut end of the wires going to the ICMC Board and connect to economizer wires as per the appropriate hookup diagrams. Cap the ends of the Yellow and Yellow/Red wires not being hooked up. Secure all wires with wire ties so that there is no interference with any moving parts or sharp edges in the unit.

CAUTION

Be certain to cap the ends of the cut YL/RD and YL wires that are not being connected to an accessory or the unit to reduce the risk of a short.

2. In the Control Box, complete the wiring connections per the appropriate wiring diagram. Note that 2 additional blue wires separate from the harness have been provided for installations in R454b (A2L) models that have a mitigation board. The longer of the 2 blue wires is to be connected to the mitigation board as shown in the wiring diagram and is to be routed to the unit low voltage control box. The shorter blue wire is to be connected to the mitigation board as shown in wiring diagram and is to be routed as needed to connect to the appropriate wires as indicated by the wiring diagram. Secure all wires so that there is no interference with any moving parts and do not come into contact with any sharp edges..
3. Power the economizer and run the checkout procedure. Make desired adjustments to the controller setting the minimum occupied damper position, the outside air setting (if enthalpy control used).
4. Replace the unit Coil access panel, the Blower access panel, and the Control/Heat access panel.

INSTALLER'S GUIDE

Installing the BAYECON Gears

1. (1) Gear and (1) E-Clip will be provided.
2. Line up return air blade with the gear as shown on gear install.
3. Once both gear and blade are lined up, install the E-Clip to set them in position.

Notes:

- **BAYECON105A/106A will have one of the RA blade brackets behind the bottom gear. Once economizer is set inside the unit, carefully push the bottom/back side of the economizer to pop the bracket off behind the gear to be able to lay the back of the economizer on your unit.**
- **Make sure you line up the bottom/top hole of the gear to the blade in the damper.**
- **Make sure the top of the brackets on return air blades are facing each other (screw heads facing each other) as shown.**

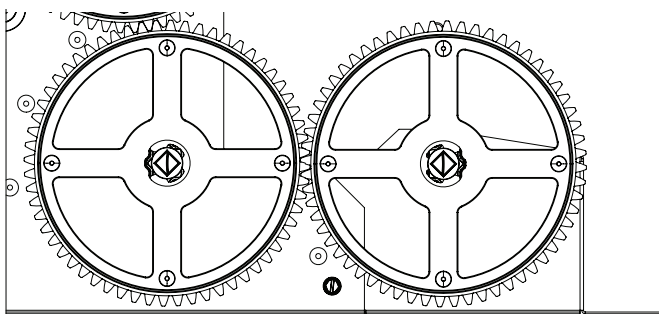
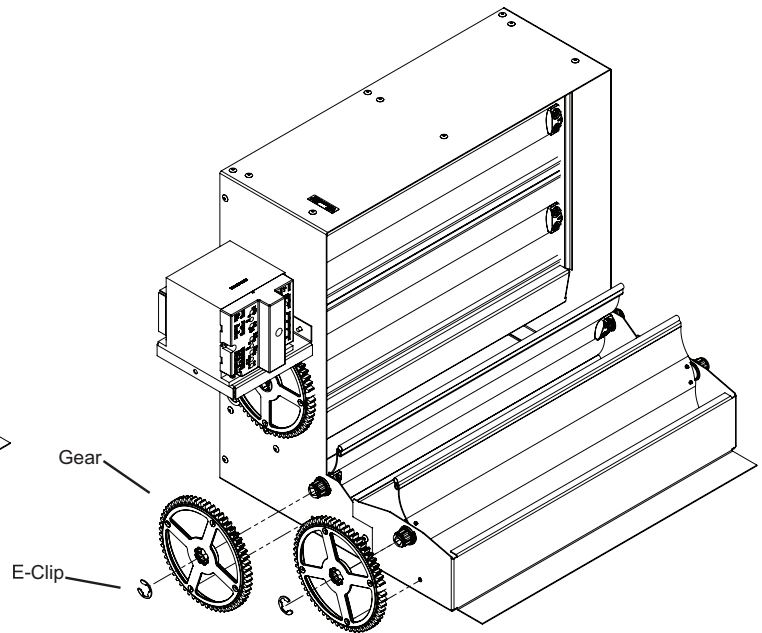
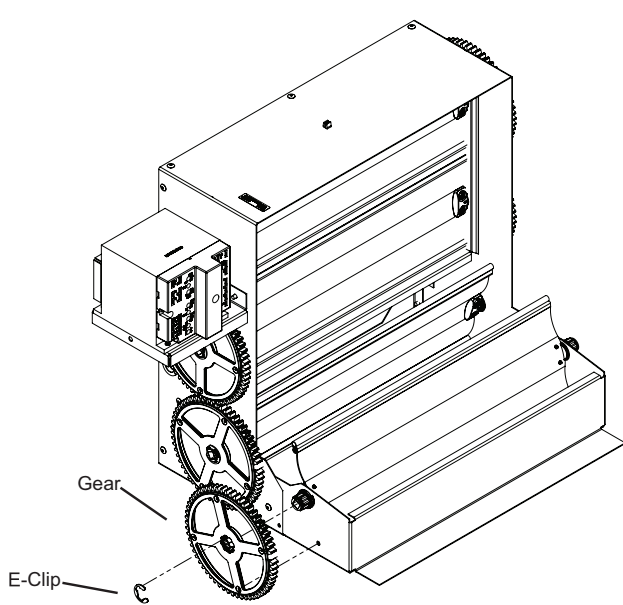

BAYECON107A GEAR INSTALL

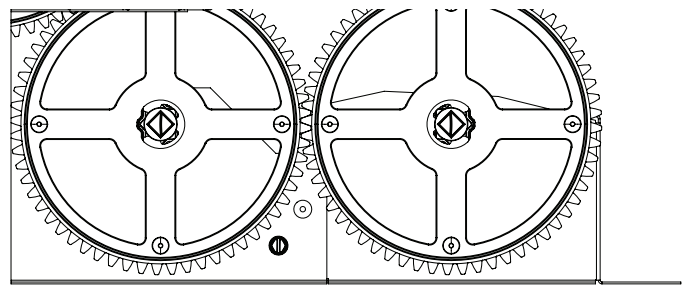

BAYECON108A GEAR INSTALL

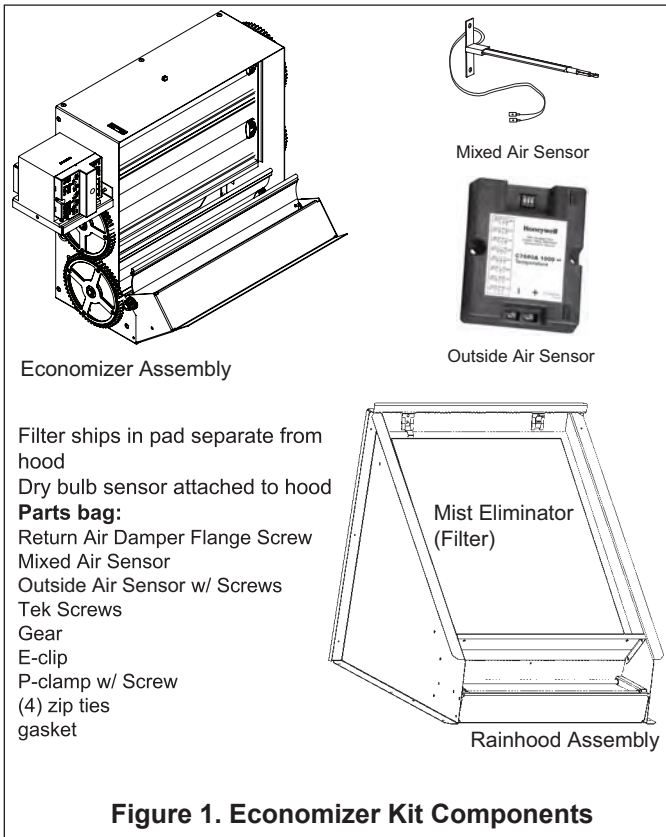

Figure 1. Economizer Kit Components

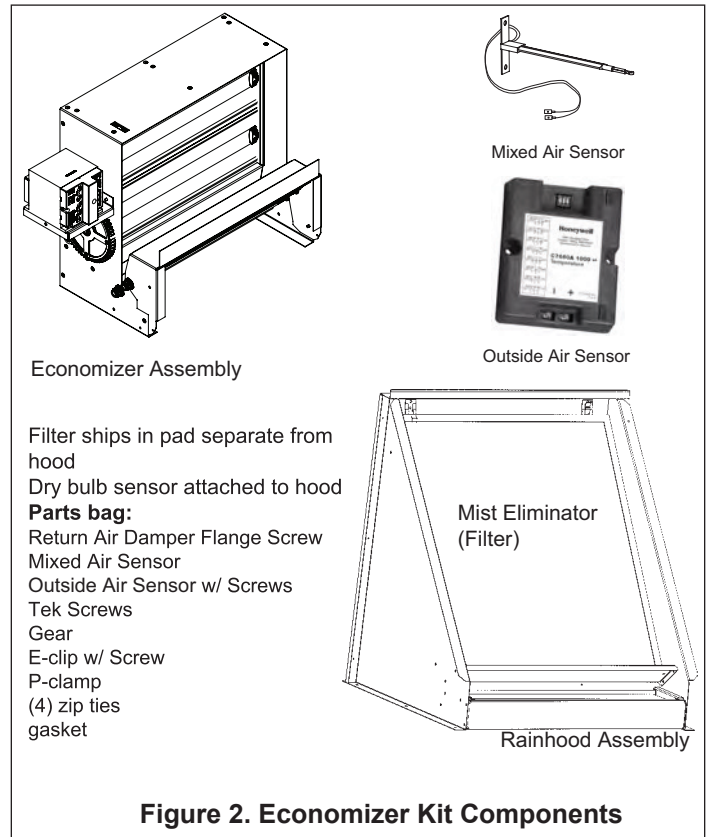

Figure 2. Economizer Kit Components

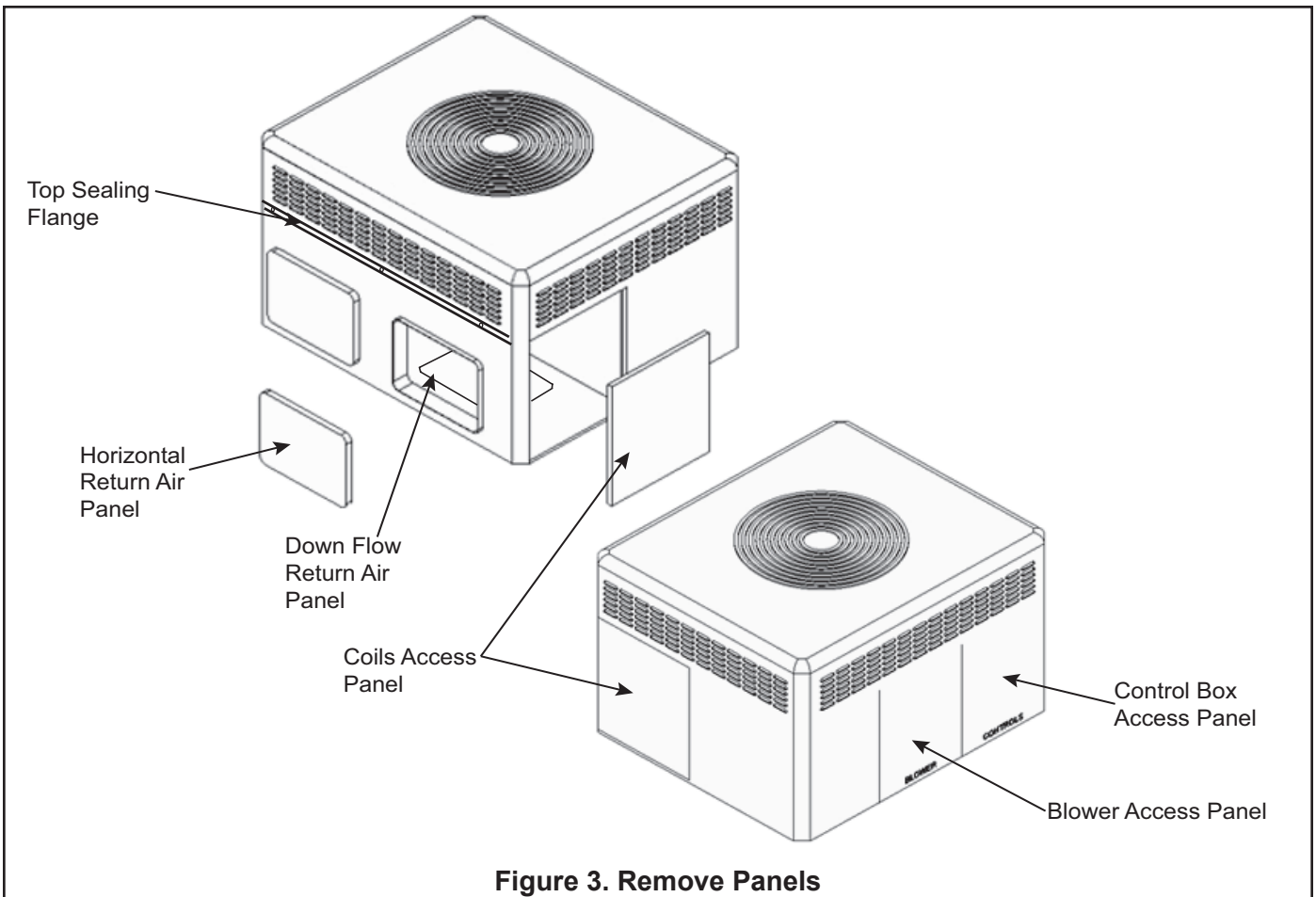

Figure 3. Remove Panels

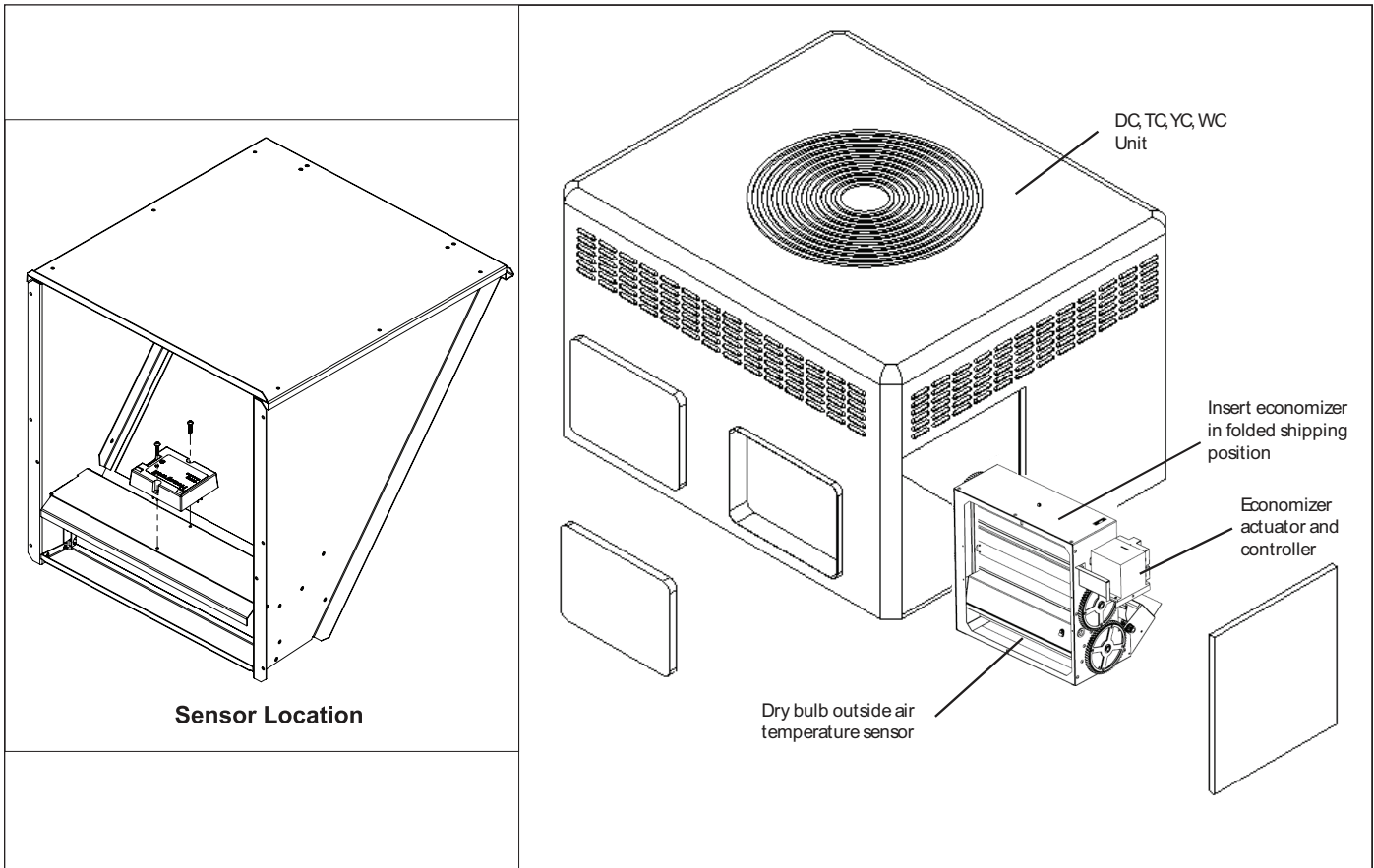

Figure 4. Insert Economizer in Shipping Position

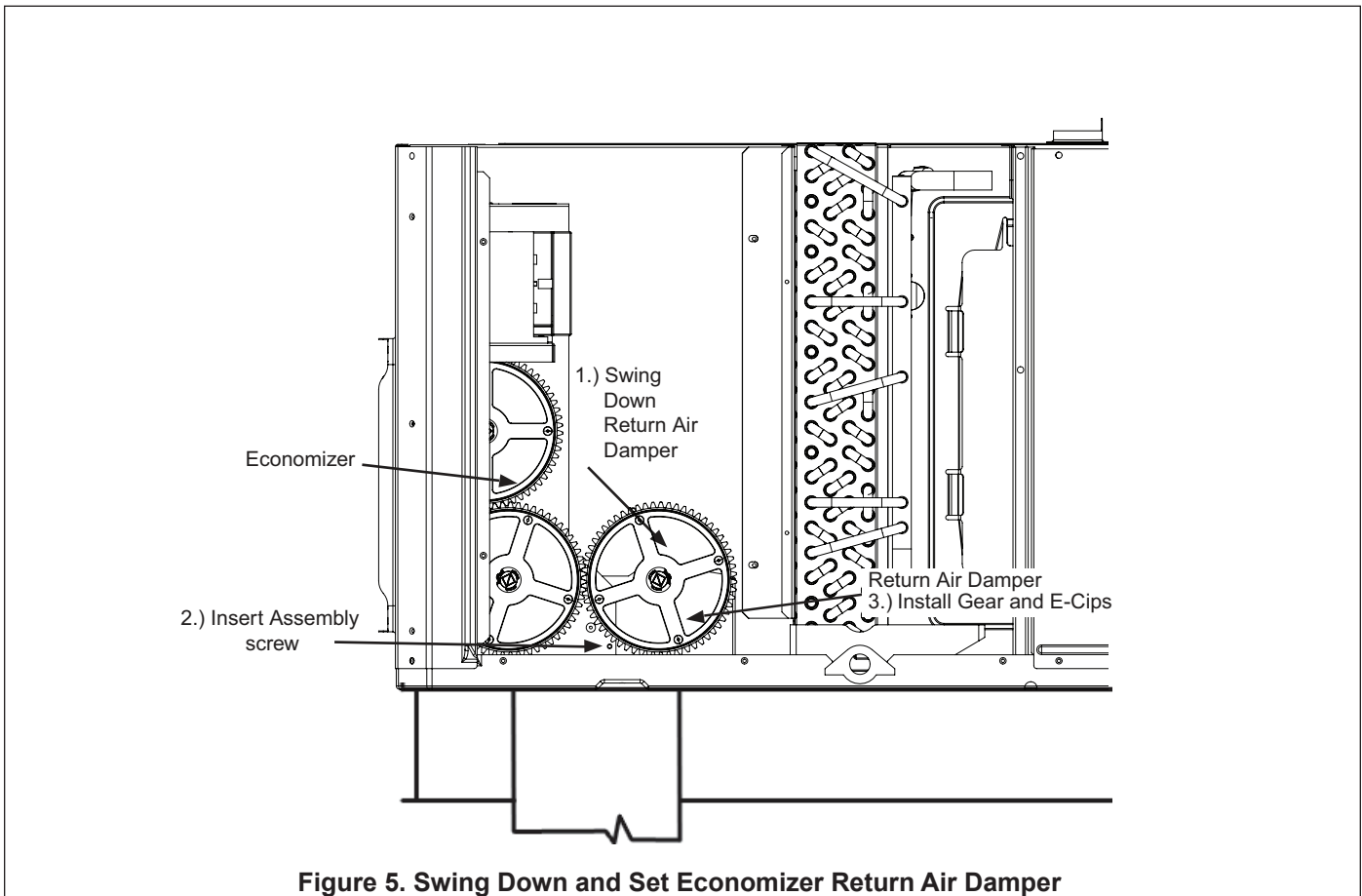
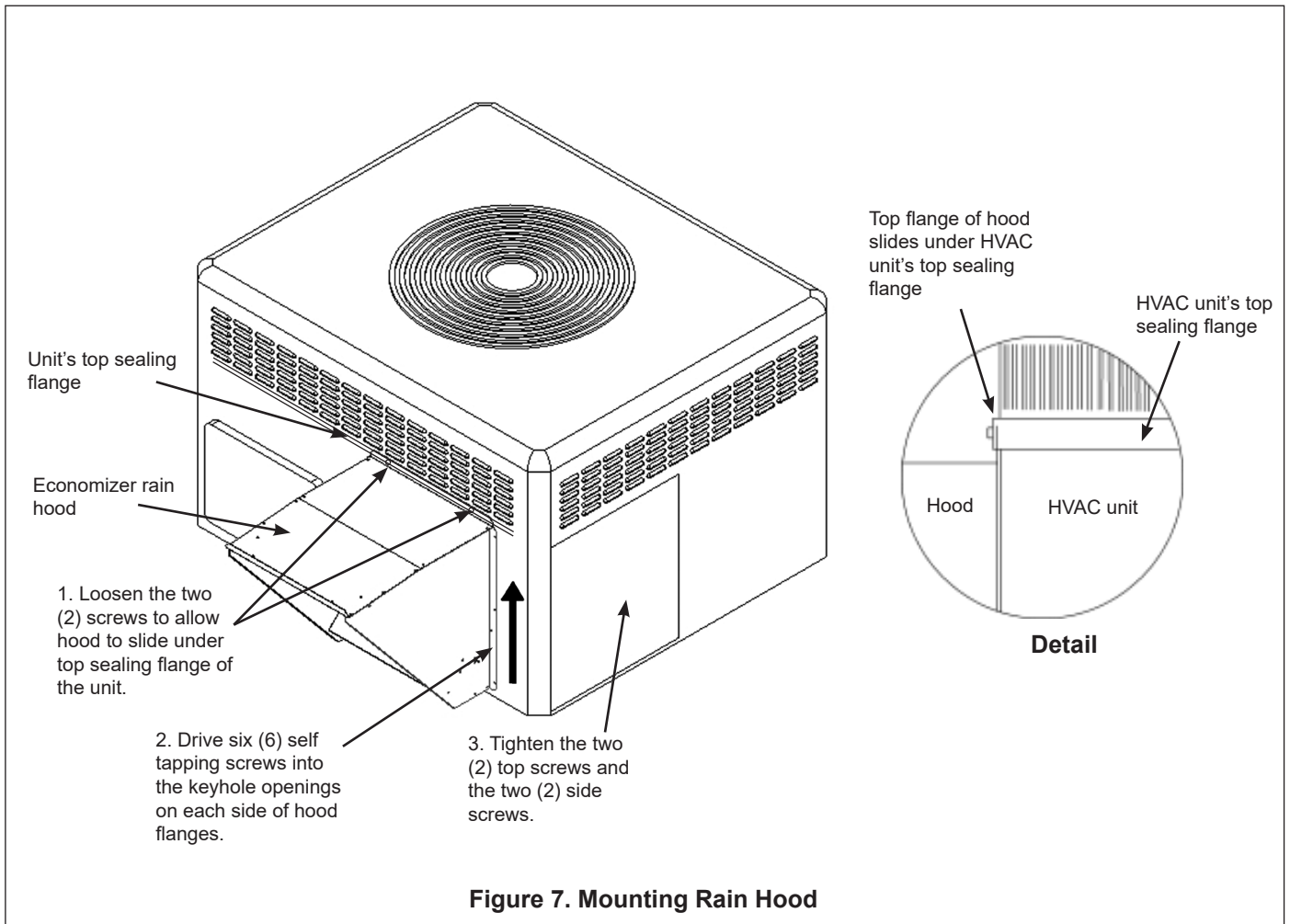
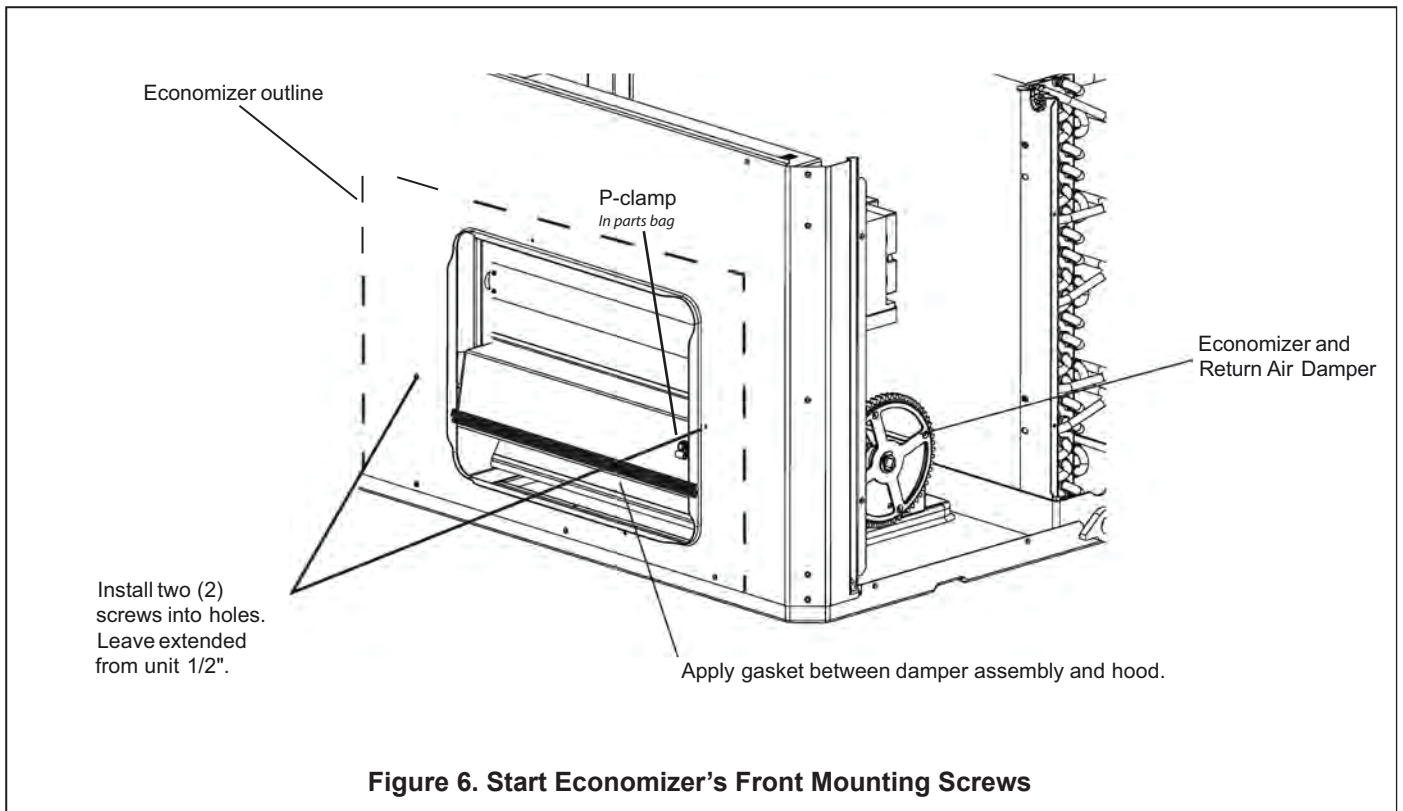

Figure 5. Swing Down and Set Economizer Return Air Damper



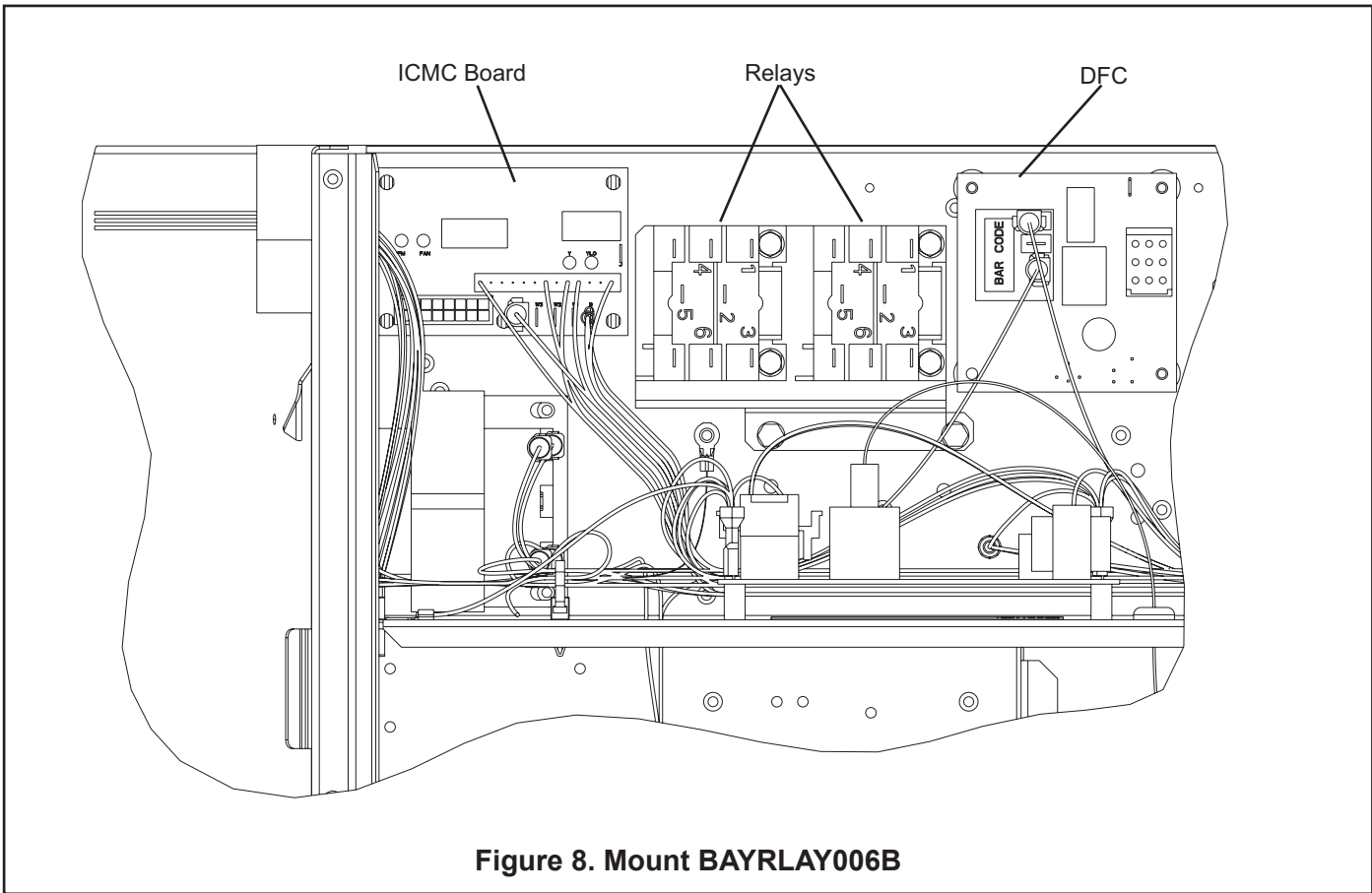

Figure 8. Mount BAYRLAY006B

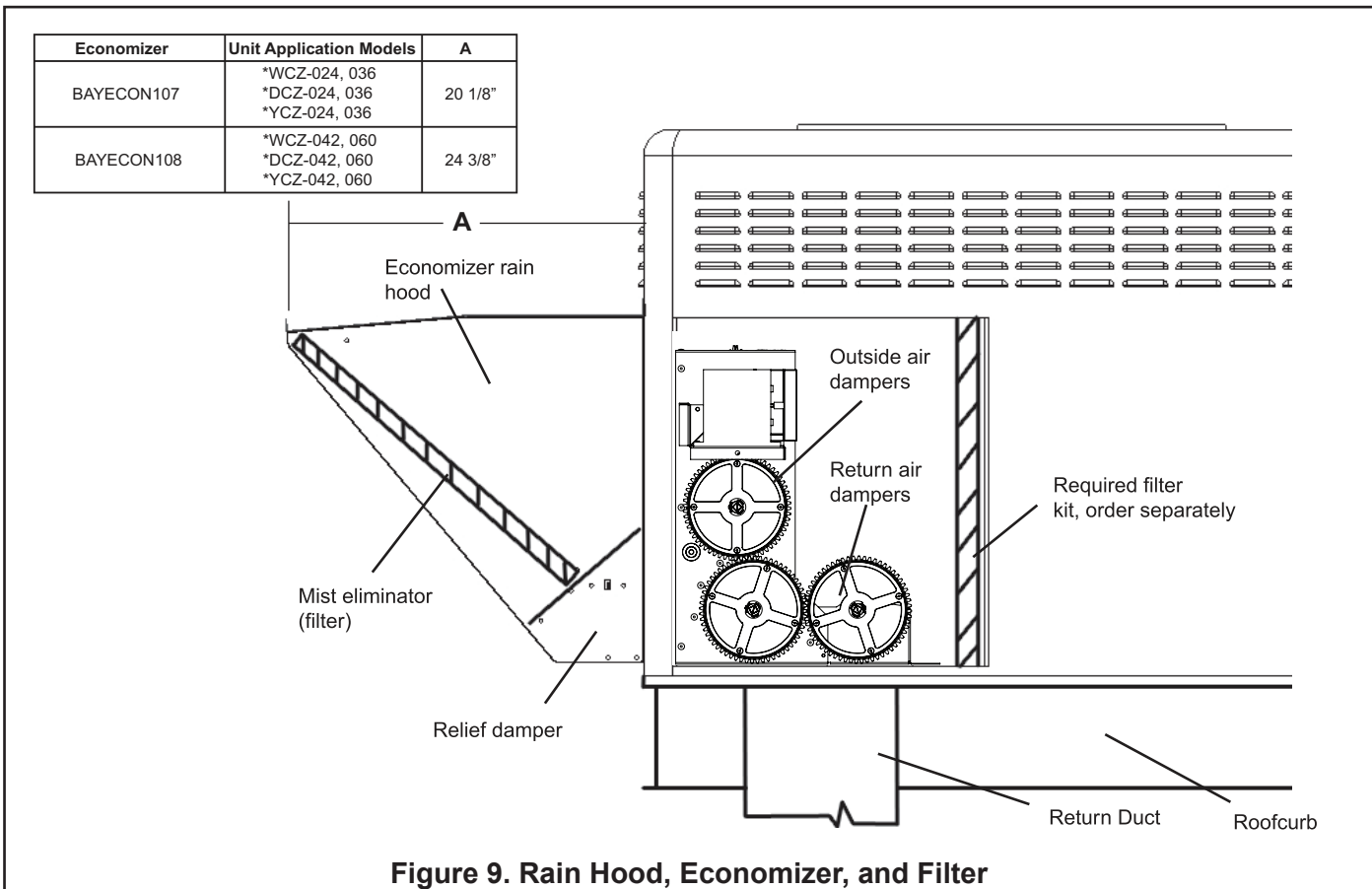
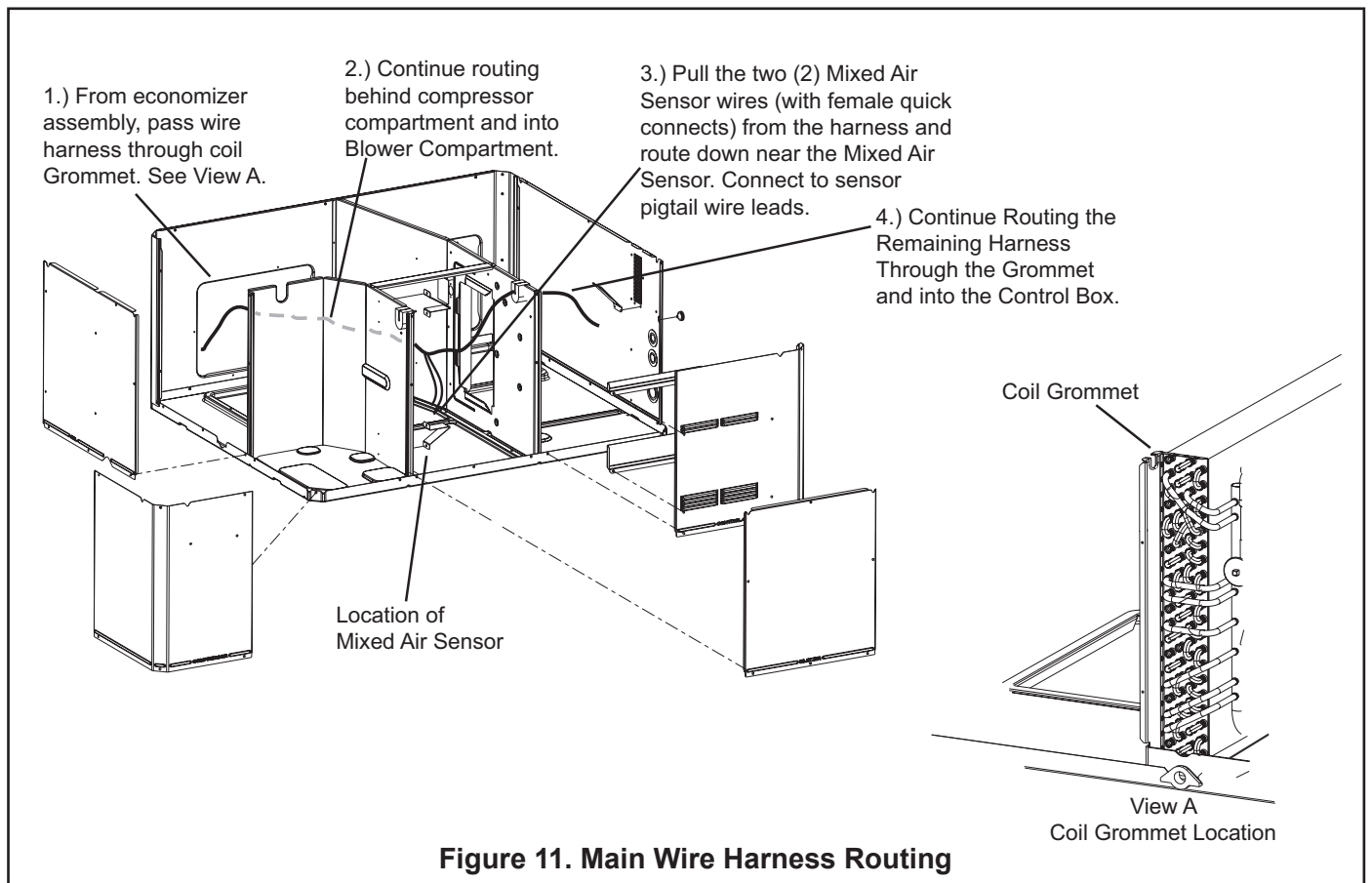
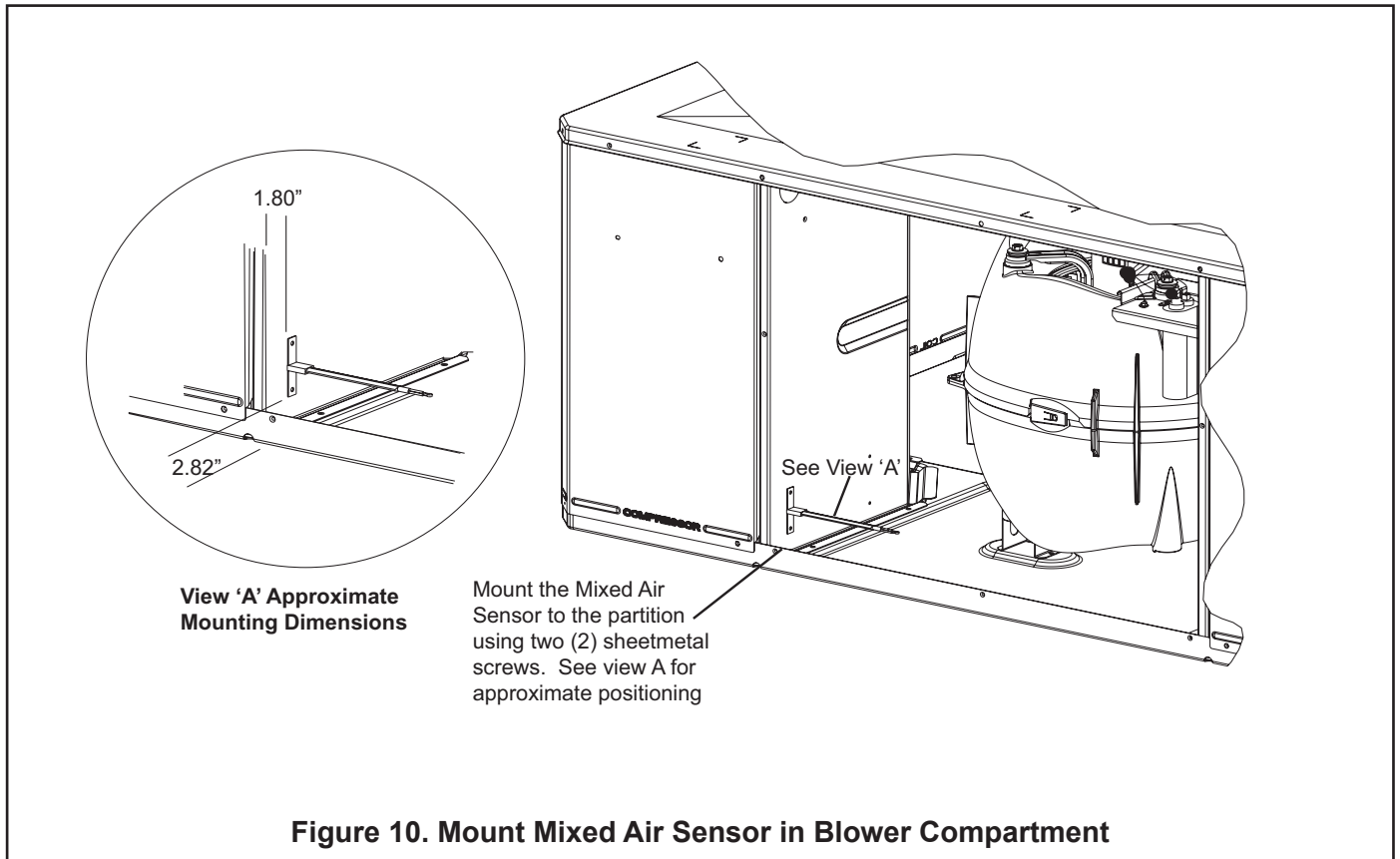

Figure 9. Rain Hood, Economizer, and Filter



Wiring Diagram for Economizer Using a Honeywell W7212 Logic

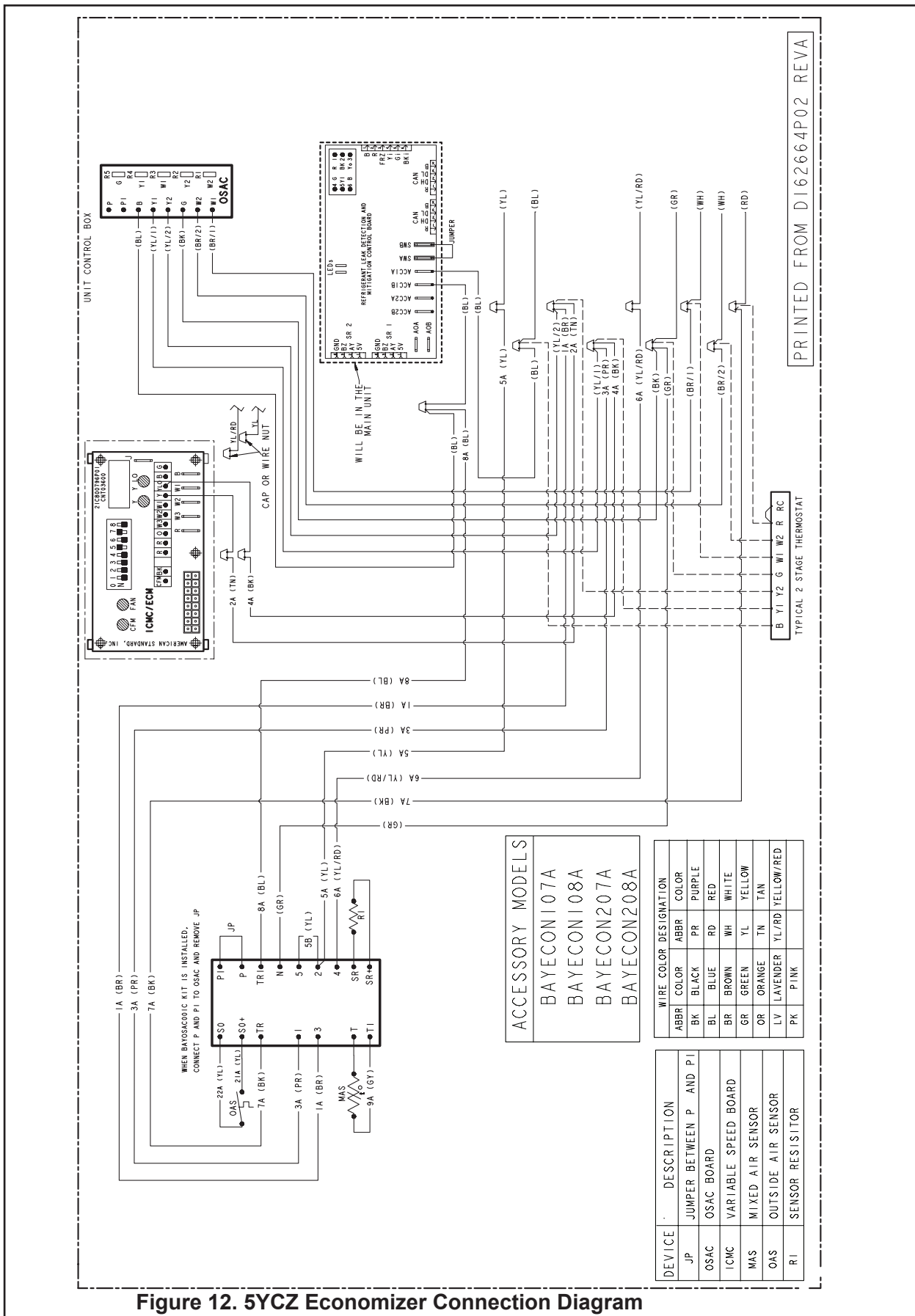

Figure 12. 5YCZ Economizer Connection Diagram

IMPORTANT-Retain this wiring diagram; please return this document to service information pack upon completion of work.

Wiring Diagram for Economizer Using a Honeywell W7212 Logic

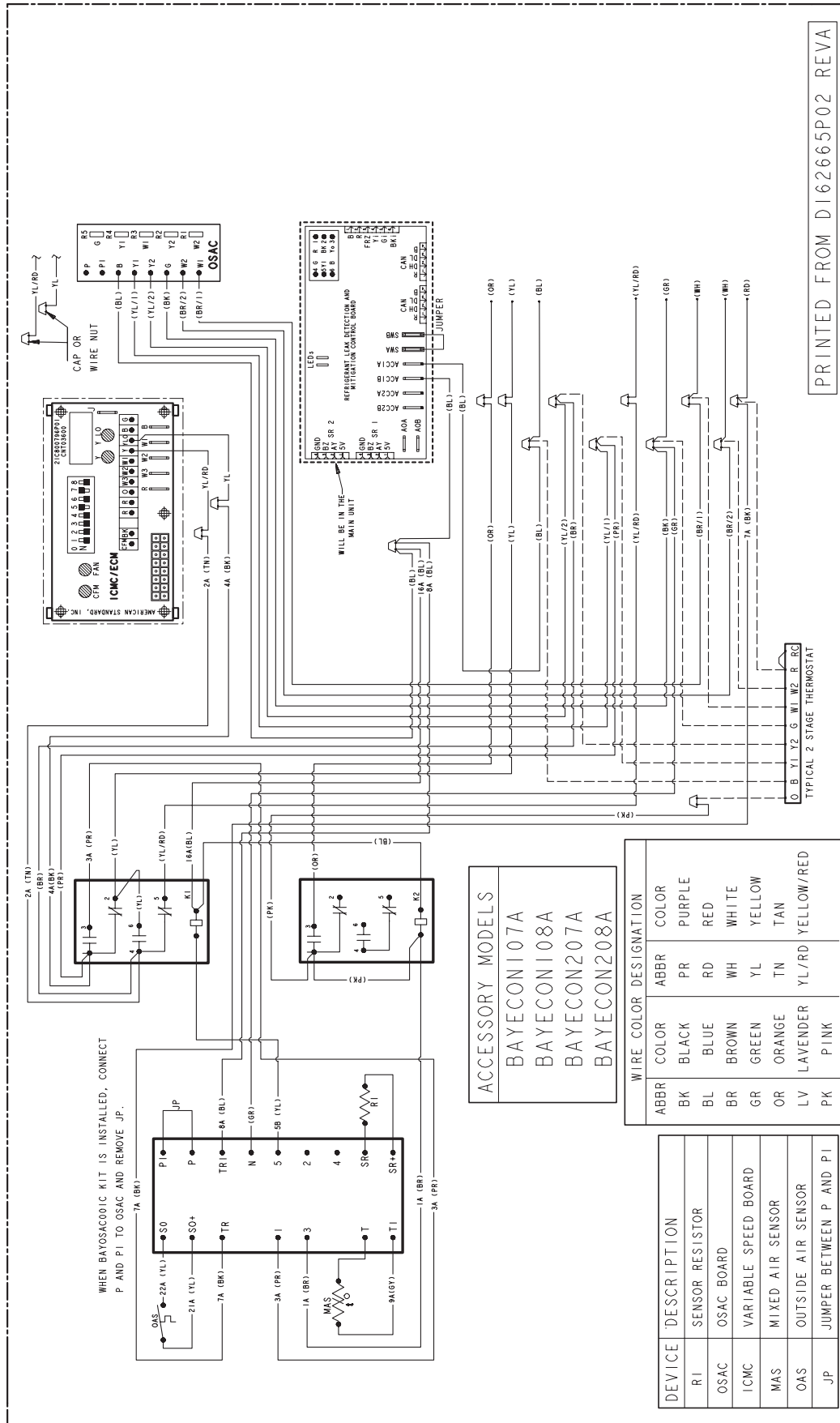

Figure 13. 5WCZ/DCZ Economizer Connection Diagram

IMPORTANT-Retain this wiring diagram; please return this document to service information pack upon completion of work.

Wiring Diagram for Economizer Using a Honeywell W7212 Logic

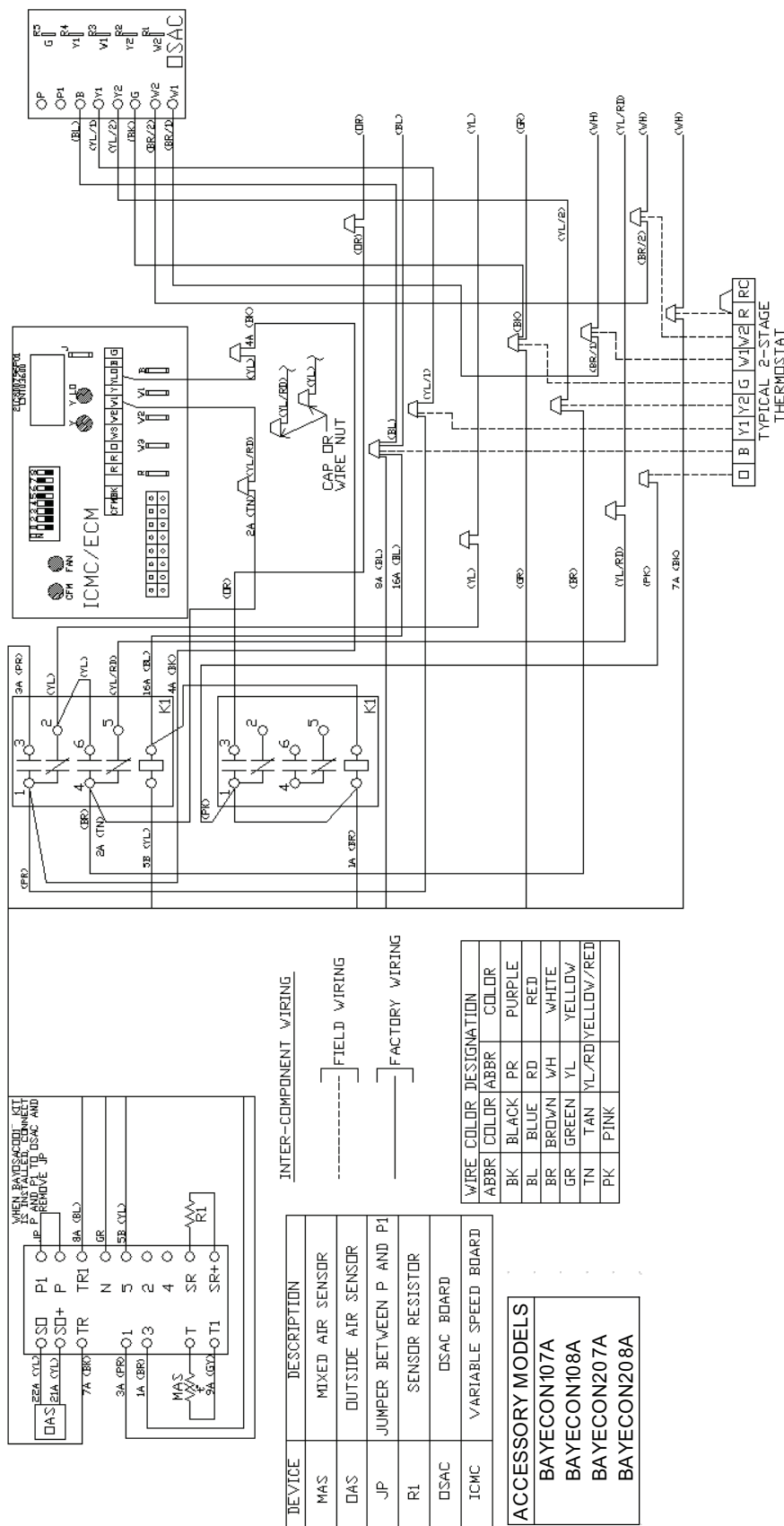

Figure 14. 2/4WCZ/DCZ Economizer Connection Diagram

IMPORTANT-Retain this wiring diagram; please return this document to service information pack upon completion of work.

Wiring Diagram for Economizer Using a Honeywell W7212 Logic

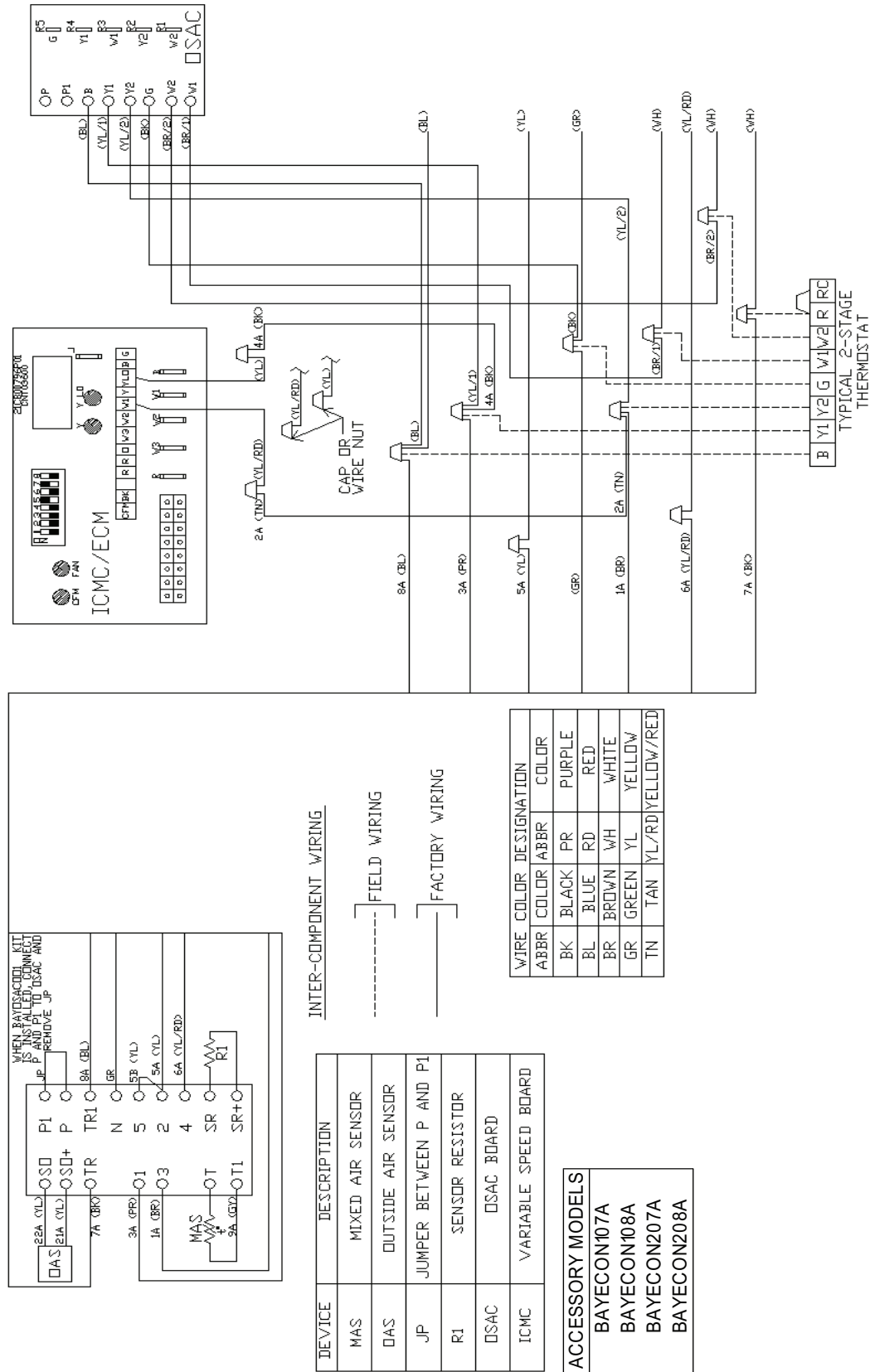

Figure 15. 2/4YCZ Economizer Connection Diagram

IMPORTANT-Retain this wiring diagram; please return this document to service information pack upon completion of work.

INSTALLER'S GUIDE

Sequence Of Operation

NOTE: A (G) signal is required for the economizer to operate. As shipped, the economizer will not operate when there is a signal for Heating Modes utilizing gas heat.

Fan Only (G): When the thermostat sends a signal for fan only (G), the economizer will open to the minimum position regardless of the outdoor air conditions and the indoor blower will operate at approximately 50% airflow.

Heating (W1), (W2), (Y1, Y2 on Heat Pump or Dual Fuel Models): When the thermostat sends a signal for auxiliary heat (G) +(W1) or first stage heat (G) + (Y1,Y2), the economizer will open to the minimum position setting. When the ambient temperature may be below 70°F, the economizer will not fully open to the economizing position, when there is a signal for heat. In order to receive fresh air and open the dampers to the minimum position setting, you must provide a G signal to the unit from the thermostat or comfort control being used.

FREE COOLING NOT AVAILABLE: When the outdoor air conditions are not sufficient for "Free Cooling" the Economizer will open to the minimum position setting only and the unit will function.

FREE COOLING AVAILABLE:

1st Stage Cooling (Y1) + (O for Heat Pumps and Dual Fuel models): When outdoor air conditions are sufficient for "Free Cooling" and the thermostat sends a signal for 1st stage cooling (G) + (Y1) + (O for Heat Pumps and Dual Fuel models), the economizer will modulate accordingly and the indoor blower will run at approximately 70% airflow.

2nd Stage Cooling (Y1) + (Y2) + (O for Heat Pumps and Dual Fuel models): When outdoor air conditions are sufficient for "Free Cooling" and the thermostat sends a signal for 2nd stage cooling (G) + (Y1) + (Y2) + (O for Heat Pumps and Dual Fuel models), the economizer will modulate accordingly, the compressor will operate on low speed, and the indoor blower will operate at 100% airflow.

Unit "OFF" Mode

When the economizer is not receiving a 24V signal to the TR terminal, or if power is disconnected to the unit, the dampers will be fully closed to the outside air and fully open to the return air.

NOTE: Free Cooling refers to the process of circulating unconditioned outside air, without operating the compressor, to cool the structure.

Single enthalpy: The enthalpy changeover set point is set to return the outdoor air damper to minimum position when the enthalpy rises above its set point. The enthalpy set point scale markings, located on W7459, are A,B,C,D; see table for the corresponding control point. The factory-installed R4 WHITE 620-ohm jumper must be in place across terminals + and SR.

CONTROL CURVE	CONTROL POINT APPROX. F (C) AT 50% RH
A	73 (23)
B	70 (21)
C	67 (19)
D	63 (17)

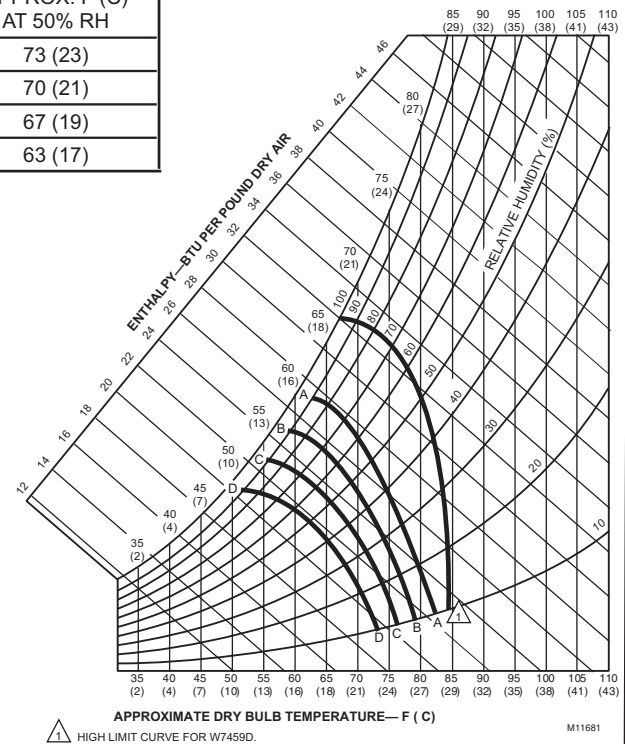

Figure 16. Single Enthalpy Changeover Set Point

Table 1. Motor Operation Checkout - W7459 Control Only

DRIVE MOTOR OPEN	DRIVE MOTOR CLOSED	SPRING RETURN
Power to TR and TR1, jumper T and T1	Disconnect jumper at T or T1 and disconnect P or P1, if connected	Disconnect power at TR and TR1

Table 2. Temp vs. OHM Values for MAS (Mixed Air Sensor)

Temp F	Temp C	R(K OHMS)	DC Volts
33.8	1	9.576	3.910
35.6	2	9.092	3.882
37.4	3	8.636	3.894
39.2	4	8.204	3.863
41.0	5	7.796	3.829
42.8	6	7.412	3.790
44.6	7	7.048	3.749
46.4	8	6.705	3.713
48.2	9	6.380	3.674
50.0	10	6.073	3.634
51.8	11	5.782	3.590
53.6	12	5.507	3.550
55.4	13	5.247	3.507
57.2	14	5.000	3.420
59.0	15	4.767	3.373
60.8	16	4.545	3.328
62.6	17	4.335	3.283
64.4	18	4.136	3.239
66.2	19	3.948	3.180
68.0	20	3.769	3.157
69.8	21	3.599	3.118
71.6	22	3.437	3.080
73.4	23	3.284	3.034
75.2	24	3.138	3.007
77.0	25	3.000	2.971
78.8	26	2.869	2.932
80.6	27	2.744	2.896
82.4	28	2.625	2.860
84.2	29	2.512	2.824
86.0	30	2.404	2.787
87.8	31	2.301	2.750
89.6	32	2.204	2.714
91.4	33	2.111	2.676
93.2	34	2.023	2.639
95.0	35	1.938	2.600
96.8	36	1.858	2.561
98.6	37	1.781	2.526
100.4	38	1.708	2.484

INSTALLER'S GUIDE

CHECKOUT - For Units with a Honeywell W7212 Control

CHECKOUT AND TROUBLESHOOTING

Checkout requires a 9V battery, 620 ohm, 1.2K ohm, 5.6K ohm, and 6.8K ohm resistors. Use Table 4 and Fig. 18 for checkout.

CAUTION

Equipment Damage Hazard.
Excessive force can damage potentiometer controls. Use a small screwdriver when adjusting enthalpy changeover and minimum damper position controls.

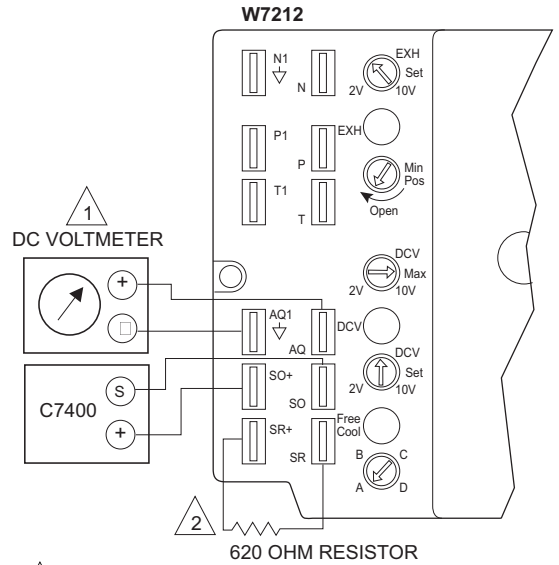

- 1 INSERT DC VOLT METER BETWEEN AQ AND AQ1 FOR CHECKOUT AND TROUBLESHOOTING.
 - 2 JUMPER USED FOR SINGLE ENTHALPY CONTROL.
- M20612

Fig. 17. Meter location for checkout and troubleshooting (W7212 shown).

Table 3. Checkout for W7212, W7213, W7214 Economizer Connected to Honeywell Actuator

Step	Checkout Procedure	Proper Response
1.	CHECKOUT PREPARATION FOR ECONOMIZING ONLY	
	Disconnect power at TR and TR1	All LED are off; Exhaust Fan contacts are open
	Disconnect devices at P and P1	
	Jumper P to P1 (defaults to on board MIN POS potentiometer).	
	Place 5.6K ohm resistor across T and T1 (Blue sleeve-provides input to economizer that the MAT is between 50-55F).	
	Jumper TR to 1 (call for cooling from the thermostat).	
	W7212 only jumper TR to N (places economizer in occupied mode).	
	If connected, remove C7400 Enthalpy Sensor from terminals S _o and +.	
	Connect 1.2K ohm, from 4074EJM Checkout Resistor kit, (purple sleeve) across terminals S _o and + (makes OA enthalpy high).	
	Place 620 ohm resistor (white sleeve) across S _r and + (makes return enthalpy lower than OA).	
	Set MIN POS and DCV MAX potentiometers fully CCW.	
	Turn DCV setpoint potentiometer mid position (this sets the DCV ventilation at approximately 1000 ppm).	
	Turn exhaust potentiometer to mid position (motor will be approximately 50% open when the exhaust fan contacts make).	
Set enthalpy potentiometer to D.		
W7214 only Jumper TR to O.		
Apply power (24 Vac) to terminals TR and TR1		

Table 3. Checkout for W7212, W7213, W7214 Economizer Connected to Honeywell Actuator (Cont.)

Step	Checkout Procedure	Proper Response
2.	DIFFERENTIAL ENTHALPY	
	Execute stop one, Checkout Preparation.	—
	Turn DCV MAX to mid position.	
	Place 620 ohm resistor across S _O and + (white sleeve resistor makes OA enthalpy low).	
	Place 1.2K ohm resistor across S _R and + (purple sleeve resistor makes RA enthalpy high).	Free cool LED turn on; motor drives to approximately 45 degrees (half) open.
	Remove 620 ohm resistor from S _O and +.	Free cool LED turn off; motor drives closed
3.	SINGLE ENTHALPY	
	Execute stop one, Checkout Preparation.	—
	Turn DCV MAX to mid position.	
	Set enthalpy potentiometer to A (fully CCW).	Free cool LED turns on; motor drives to approximately 45 degrees (half) open.
	Set enthalpy potentiometer to D or E for W7212C (fully CW).	Free cool LED turns off; motor drives closed.
4.	DCV AND EXHAUST	
	Execute step one, Checkout Preparation.	—
	LED for both DCV and Exhaust should be off.	
	Turn DCV MAX to mid position.	Motor drives to mid position, 45 degrees open.
	Turn MIN POS fully CW.	Motor drives fully open.
	Turn MIN POS and DCV MAX to fully CCW.	Motor drives closed.
	Turn DCV MAX to mid position. Connect 9V battery positive to AQ and negative to AQ1.	LED for both DCV and Exhaust turn on. Actuator drives to 45 degrees open.
	Remove jumper from N terminal (economizer goes into not occupied mode).	Motor remains at 45 degrees open.
	Adjust DCV MAX towards CW.	Motor will move to position set by DCV MAX pot.
	Adjust DCV MAX to fully CCW.	Motor will drive closed.
	Reconnect jumper to N terminal.	
	Adjust DCV MAX and MIN POS pots.	Motor will drive to the most open position of the pots.
	Adjust DCV MAX and MIN POS pots to fully CCW.	
	Remove power from N terminal adjust MIN POS towards CW.	Motor should not move.
Adjust DCV MAX towards CW.	Motor will move to position set by DCV MAX pot.	
5.	MINIMUM AND MAXIMUM POSITION	
	Execute stop one, Checkout Preparation.	—
	Connect 9V battery positive to AQ and negative to AQ1. Adjust DCV MAX potentiometer to mid position.	DCV LED turns on. Actuator drives to 45 degrees open.
	Turn DCV maximum position potentiometer to fully CCW.	Actuator drives fully closed.
	Turn minimum position potentiometer to midpoint.	Actuator drives to 45 degrees open.
	Turn minimum position potentiometer fully CW.	Actuator drives fully open.
	Turn MIN POS to fully CCW.	Actuator drives fully closed.
	W7212: Remove jumper from TR and N. W7214: Jumper TR to O.	Actuator drives fully closed.
	6.	MIXED AIR INPUT
Execute stop one, Checkout Preparation.		—
Turn DCV MAX to mid position; set enthalpy potentiometer to A.		Free cool LED turns on. Actuator drives to 45 degrees open.
Remove 5.6K ohm resistor (green sleeve) and place jumper from T and T1.		Actuator drives to 45 degrees open.
Remove jumper from T and T1 and leave open.		Actuator drives fully closed.

Troubleshooting - No Minimum Fresh Air

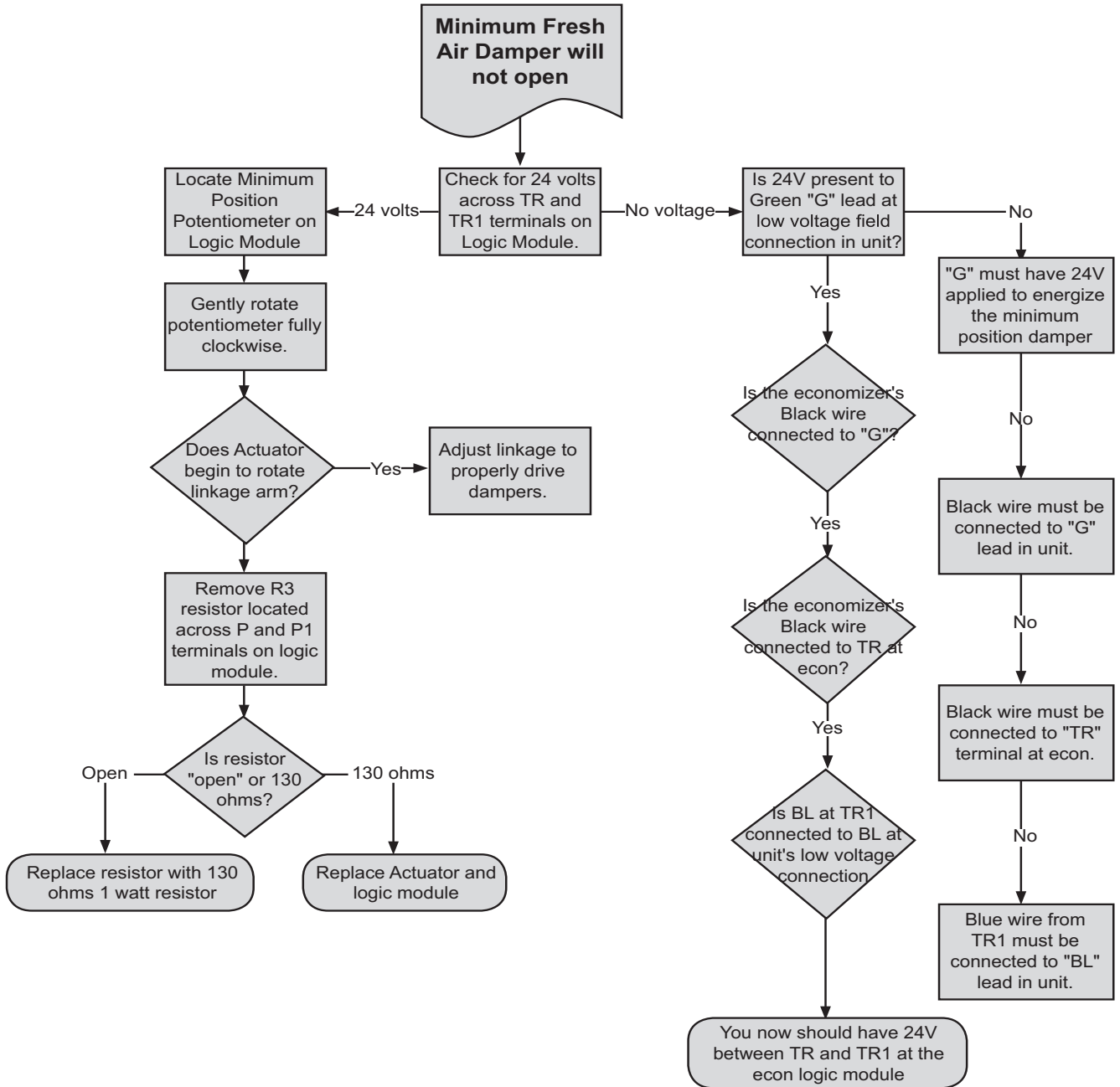

Troubleshooting - Unit Will Not Economize

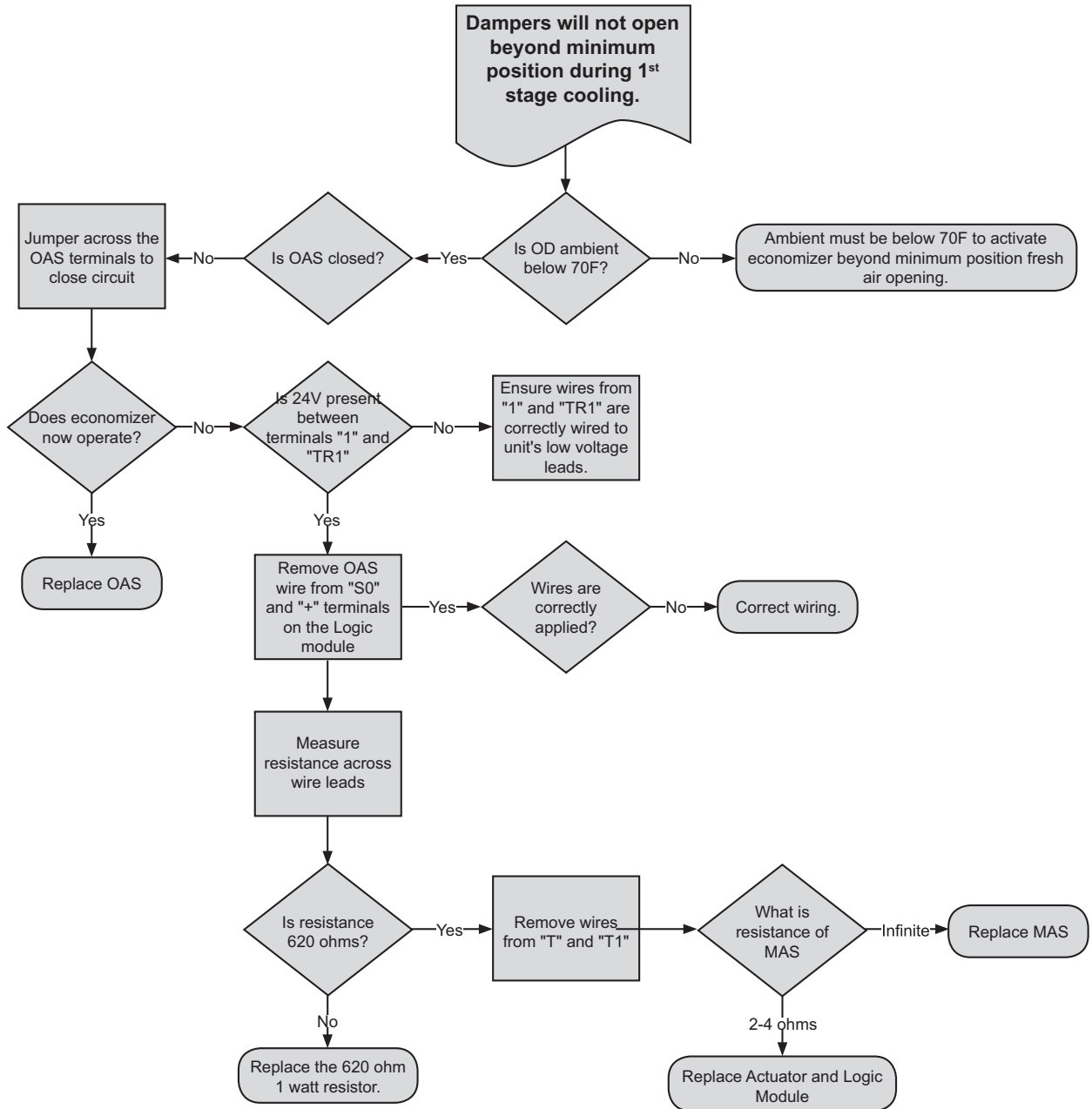

Troubleshooting - 2nd Stage Inoperable

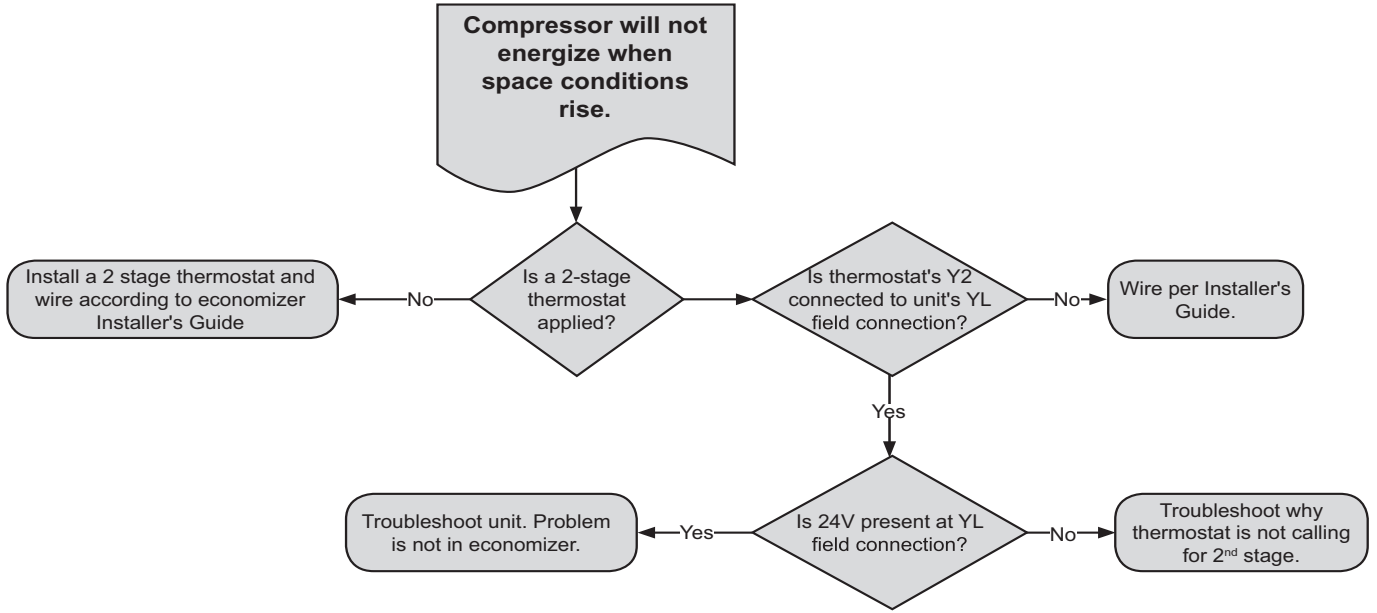

Troubleshooting - Dampers Open With G

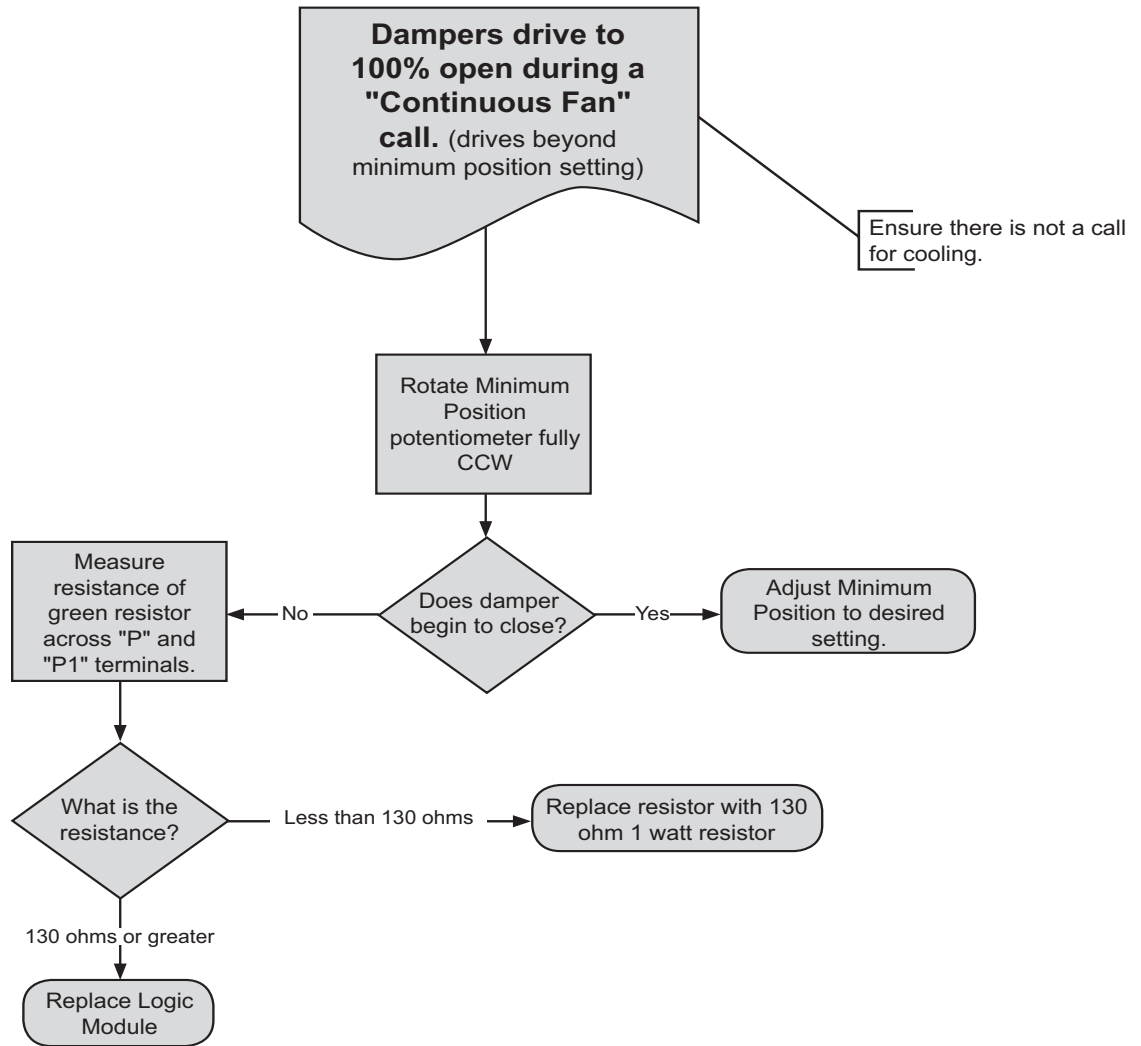

Troubleshooting - Mixed Air Sensor

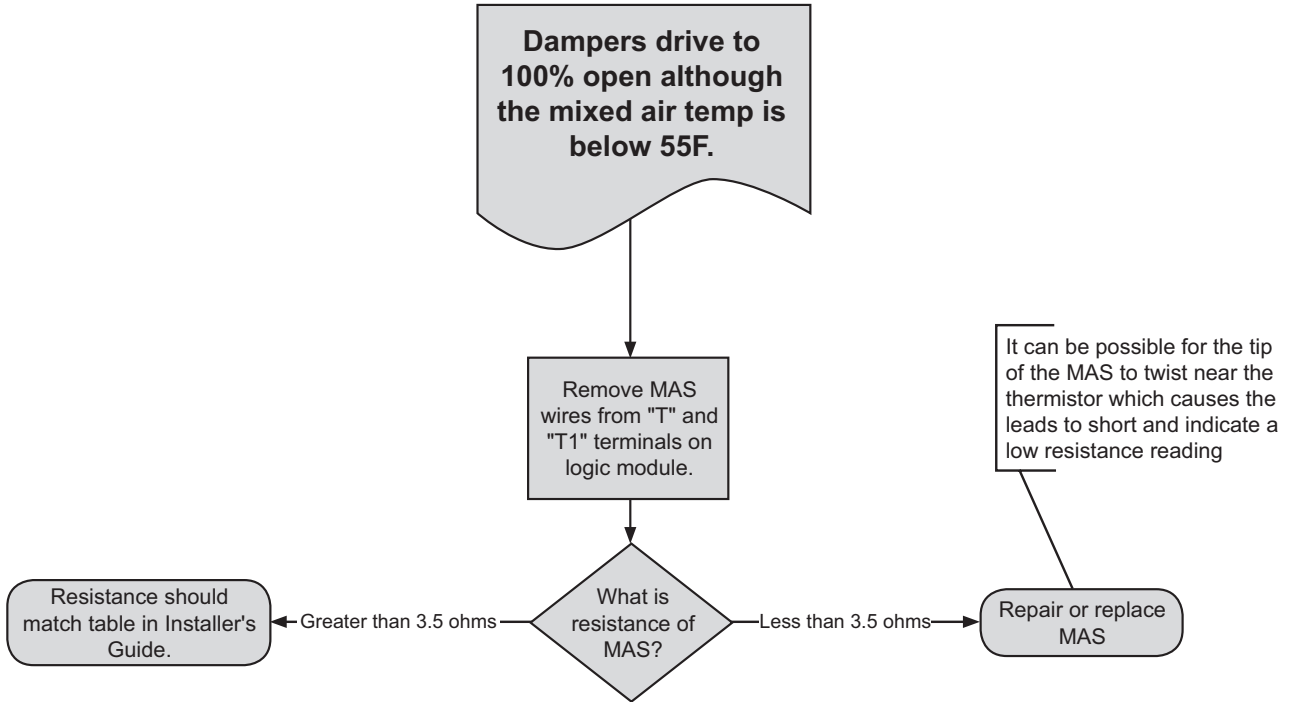

Troubleshooting - Logic Module Failures

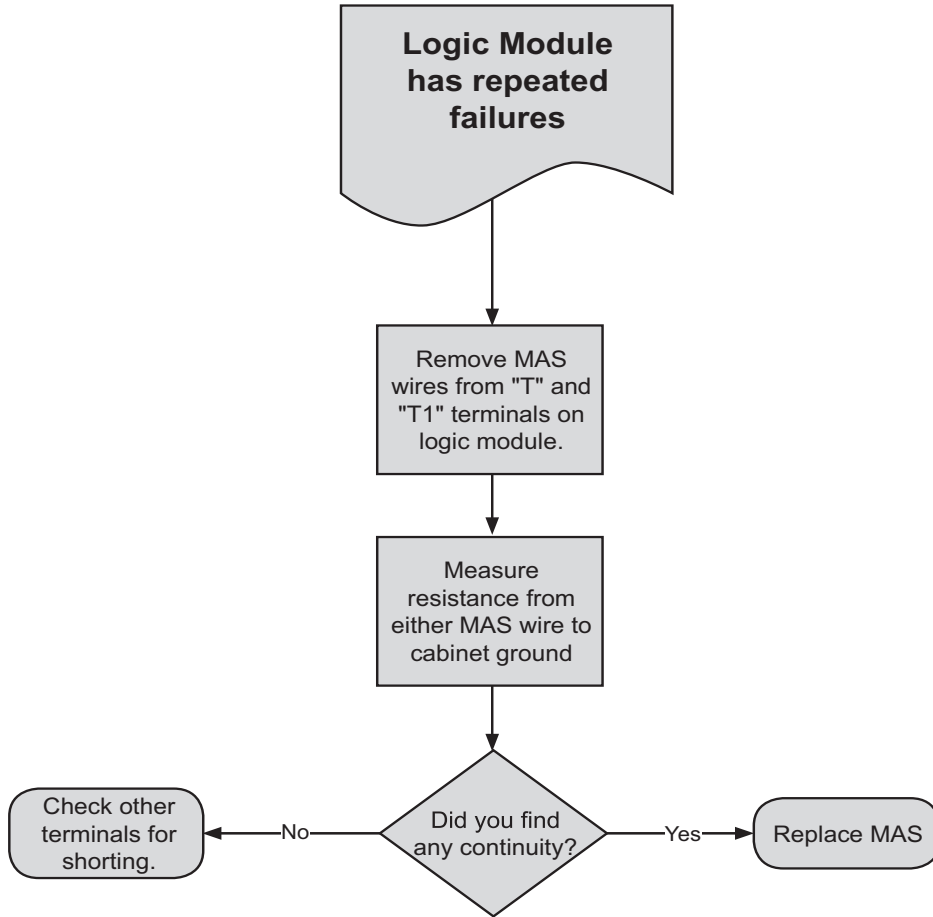

About Trane and American Standard Heating and Air Conditioning

Trane and American Standard create comfortable, energy efficient indoor environments for residential applications. For more information, please visit www.trane.com or www.americanstandardair.com

The manufacturer has a policy of continuous data improvement and it reserves the right to change design and specifications without notice. We are committed to using environmentally conscious print practices.