

EDHUM070H

INSTALLATION & OPERATION INSTRUCTIONS



The **EDHUM070H** is a ventilating dehumidifier that is integrated into the heating and cooling system to provide the ultimate in comfort, health and property protection through:

- + Dehumidification
- + Fresh Air Ventilation (Optional)
- + Air Filtration

Serial Number _____

Install Date _____

Sold By _____



TABLE OF CONTENTS

Safety Instructions.....	3
Dehumidifier Set Up.....	4
Attaching Duct Collars.....	5
Electrical Requirements.....	6
Drain Installation.....	7
Ducting to HVAC Systems.....	9
Recommended HVAC System Installation.....	9
Fresh Air Ventilation.....	10
Determine Ventilation Requirements.....	11
Controls.....	12
Wiring Controls.....	12
Air Filtration.....	13
MERV Rating Chart.....	14
Service.....	15
Warranty.....	17

Trane Technologies is committed to manufacturing quality products. To maintain our standards, product specifications may change without notice.

SAFETY INSTRUCTIONS

READ THE INSTALLATION, OPERATION AND MAINTENANCE INSTRUCTIONS CAREFULLY BEFORE INSTALLING AND OPERATING THIS DEVICE. PROPER ADHERENCE TO THESE INSTRUCTIONS IS ESSENTIAL TO OBTAIN MAXIMUM BENEFIT FROM YOUR WHOLE HOUSE VENTILATING DEHUMIDIFIER.

⚠ WARNING!

THIS SYMBOL MEANS IMPORTANT INSTRUCTIONS. FAILURE TO HEED THEM CAN RESULT IN SERIOUS INJURY OR DEATH.

⚠ CAUTION!

THIS SYMBOL MEANS IMPORTANT INSTRUCTIONS. FAILURE TO HEED THEM CAN RESULT IN INJURY OR MATERIAL PROPERTY DAMAGE.

Registrations



This Trane dehumidifier conforms to unified standard UL 60335-2-40 and CSA Standard C22.2.60335-2-40.

⚠ WARNING!

120 VOLTS MAY CAUSE SERIOUS INJURY FROM ELECTRIC SHOCK. DISCONNECT ELECTRICAL POWER BEFORE STARTING INSTALLATION OR SERVICING, AND LEAVE POWER DISCONNECTED UNTIL INSTALLATION OR SERVICE IS COMPLETED.

⚠ CAUTION!

READ ALL INSTRUCTIONS BEFORE BEGINNING INSTALLATION.
ALWAYS USE CAUTION AND WEAR CUT RESISTANT GLOVES WHEN HANDLING SHEET METAL.
IMPROPER INSTALLATION MAY CAUSE PROPERTY DAMAGE OR INJURY.
INSTALLATION, SERVICE, AND MAINTENANCE MUST BE PERFORMED BY A QUALIFIED SERVICE TECHNICIAN.
DEHUMIDIFIER IS HEAVY. HANDLE WITH CARE AND FOLLOW INSTALLATION INSTRUCTIONS.
NEVER OPERATE A UNIT WITH A DAMAGED POWER CORD. IF THE POWER CORD IS DAMAGED, IT MUST BE REPLACED BY THE MANUFACTURER, ITS SERVICE AGENT, OR A SIMILARLY QUALIFIED PERSON IN ORDER TO AVOID A HAZARD.
THIS APPLIANCE IS NOT INTENDED FOR USE BY PERSONS (INCLUDING CHILDREN) WITH REDUCED PHYSICAL, SENSORY OR MENTAL CAPABILITIES, OR LACK OF EXPERIENCE OR KNOWLEDGE, UNLESS THEY HAVE BEEN GIVEN SUPERVISION OR INSTRUCTION CONCERNING THE USE OF THE APPLIANCE BY A PERSON RESPONSIBLE FOR THEIR SAFETY. CHILDREN SHOULD BE SUPERVISED TO ENSURE THAT THEY DO NOT PLAY WITH THE APPLIANCE.

SPECIFICATIONS

▶ EDHUM070H



THE COMPACT **EDHUM070H** IS DESIGNED TO FIT IN TIGHT, LOW-CLEARANCE SPACES WHERE MOST DEHUMIDIFIERS CANNOT. IDEAL FOR SMALL HOMES, CONDO OR APARTMENT APPLICATIONS, THIS DEHUMIDIFIER IS ENERGY STAR RATED.

MODEL EDHUM070H

PERFORMANCE

Water Removal	70 Pints / 8.75 Gallons
Efficiency	5.0 Pints/kWh
Energy Factor	2.4 L/kWh
Blower	150 CFM @ 0.0" WG 140 CFM @ 0.2" WG 130 CFM @ 0.4" WG
Operating Temperature	49°F Min., 95°F Max.
Sizing	Up to 1,800 Sq. Ft. / 18,000 Cu. Ft.

ELECTRICAL

Power	580 watts @ 80°F and 60% RH
Supply Voltage	115 volt – 1 phase – 60 Hz
Current Draw	5.1 amps
Power Cord	9', 115 VAC, Ground
Circuit Requirement	15 Amps

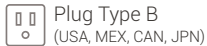

SPECIFICATIONS

Duct Connections	8" Round Inlet, 8" Round Outlet
Drain Connection	3/4" Threaded Female NPT
Refrigerant	R410A, 15 oz.
Unit Dimensions	12"W x 12"H x 28"D
Unit Weight	55 lbs.

SHIPPING

Shipping Dimensions	15"W x 16"H x 31"D
Shipping Weight	65 lbs.
Pallet Quantity	12 per pallet
UPC Number	859029004632
Shipping Options	UPS and LTL

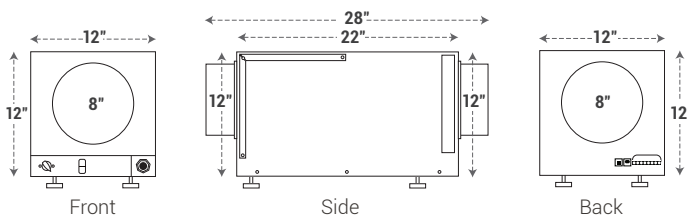

Specifications are subject to change without notice. Performance is based on pints / gallons per day @80°F/60%RH. Sizing is based on 10 foot ceiling height. Unit dimensions and weight are with collars on.

FEATURES

- + Small footprint (12" x 12" x 22") fits low profile spaces
- + Rotatable exhaust outlet provides for horizontal or vertical discharge
- + Ducting option for fresh outdoor air ventilation
- + Onboard dehumidistat with optional DEH 3000/R digital control
- + Features MERV-13 filter for superior air filtration
- + Push button reset for transformer protection



DEHUMIDIFIER SET UP

Important Precautions

- The device is designed to be installed indoors in a space that is protected from rain and flooding.
- Install the unit with enough space to access all sides for maintenance and service. The entire shell needs to be removed in order to do repairs.
- Avoid directing the discharge air at people. The dehumidifier should be used in the upright position.
- If used near a water source; be certain there is no chance the unit could fall into the water or get splashed and that it is plugged into a dedicated circuit and Ground Fault Circuit Interrupter (GFCI) protected outlet.
- DO NOT use the dehumidifier as a bench or table.
- DO NOT place the dehumidifier directly on structural building members without vibration absorbers or unwanted noise may result. Place the EDHUM070H on supports to raise the base of the unit.
- A drain pan with a float switch **MUST** be placed under the dehumidifier if installed above a living area or above an area where water leakage could cause damage.

Location Considerations

- Allow sufficient clearance to handle the unit's overall dimensions as well as the necessary return and supply ductwork to the unit.
- Allow sufficient clearance for filter removal and to prevent airflow obstruction.
- Electrical service access will require the removal of the outside shell. Allow sufficient clearance around the unit.
- Locate the dehumidifier in an area where the cord's length (9') easily reaches a 115 VAC electrical outlet with a minimum of a 15 Amp circuit capacity.
- Locate the dehumidifier in an area where field wiring the control (low voltage) to the unit will be possible.
- It is recommended that a backdraft damper be used in the discharge duct of the EDHUM070H, especially when connecting to the supply ducting system. The backdraft damper prevents supply air from counter flowing through the EDHUM070H when it is not operating. The dehumidifier's location should be chosen to allow installation of this accessory if necessary.
- The EDHUM070H may be suspended with the hang kit or a suitable alternative from structural members, ensuring the assembly supports the dehumidifier's base in its entirety. DO NOT hang the EDHUM070H from its' cabinet.
- Allow for proper drainage and routing of needed drain pipes.

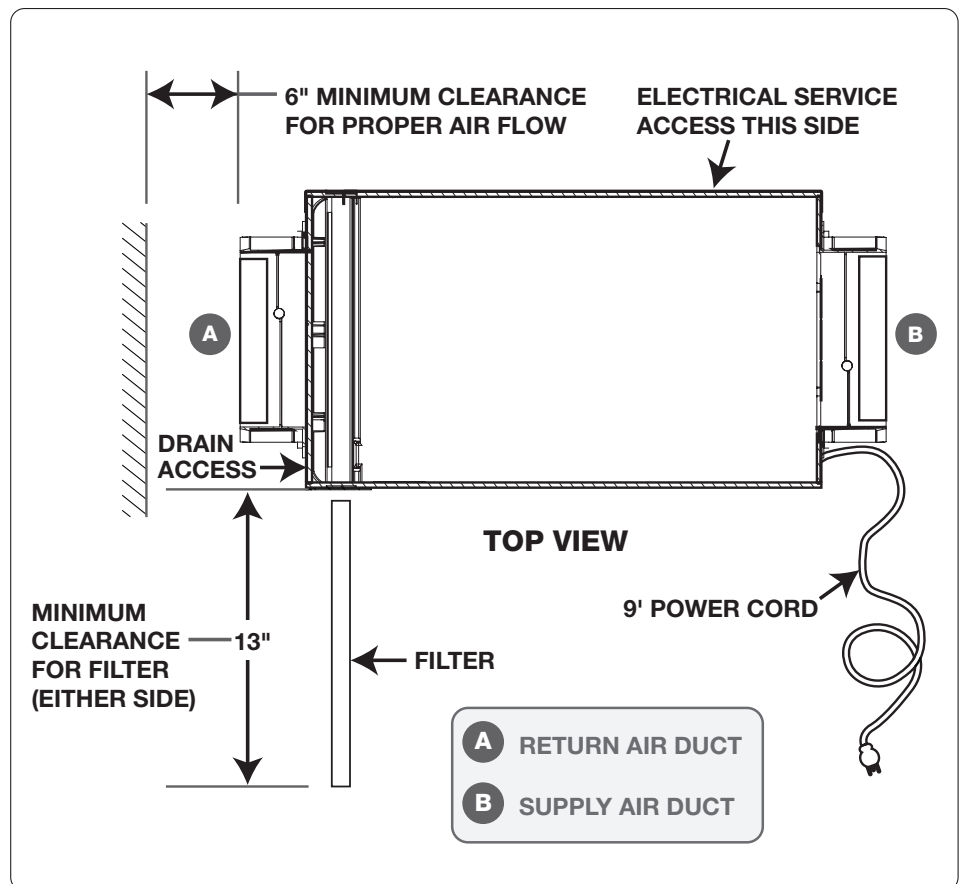

ATTACHING DUCT COLLARS

Fresh Air Ventilation Duct

Fresh air ventilation is optional. If setting up the unit to provide fresh air ventilation, see page 10.

Return Air Inlet

An 8" diameter duct collar is attached to the unit.

Supply Air Outlet

The back panel of the dehumidifier can be rotated to allow for horizontal flow through or vertical flow through of the supply air.

- **Horizontal Flow Through**

The unit ships configured for a horizontal flow through. An 8" diameter duct collar is attached to the unit.

- **Vertical Flow Through**

Remove the exhaust panel using a T20 torx bit. Rotate the panel so the exhaust collar is located on the top of the unit. Align screw holes and snap the panel onto the base. Secure the exhaust panel to the base by replacing the six screws.

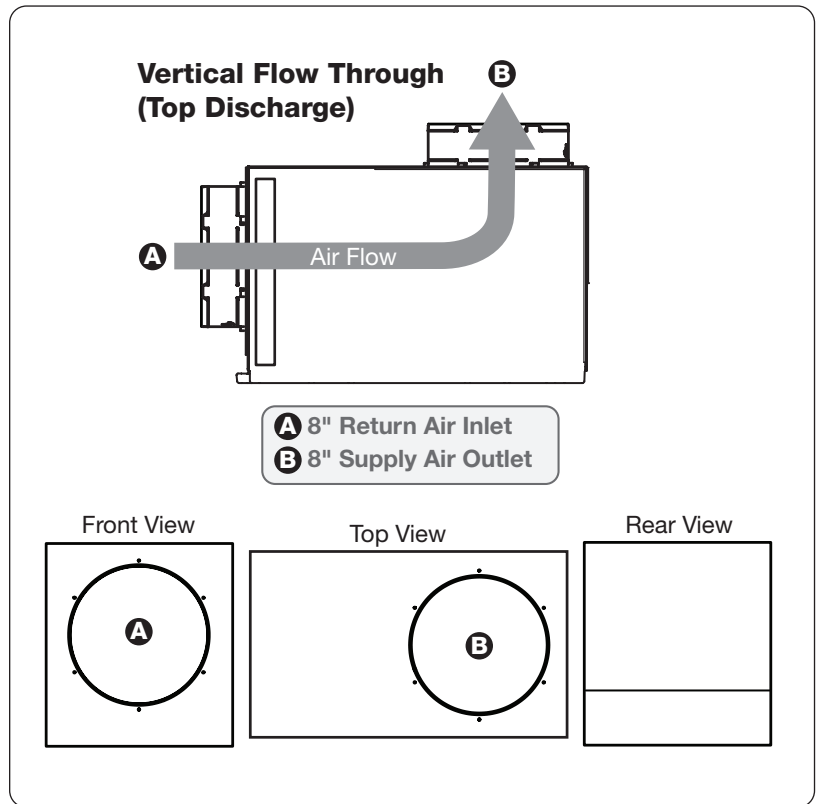
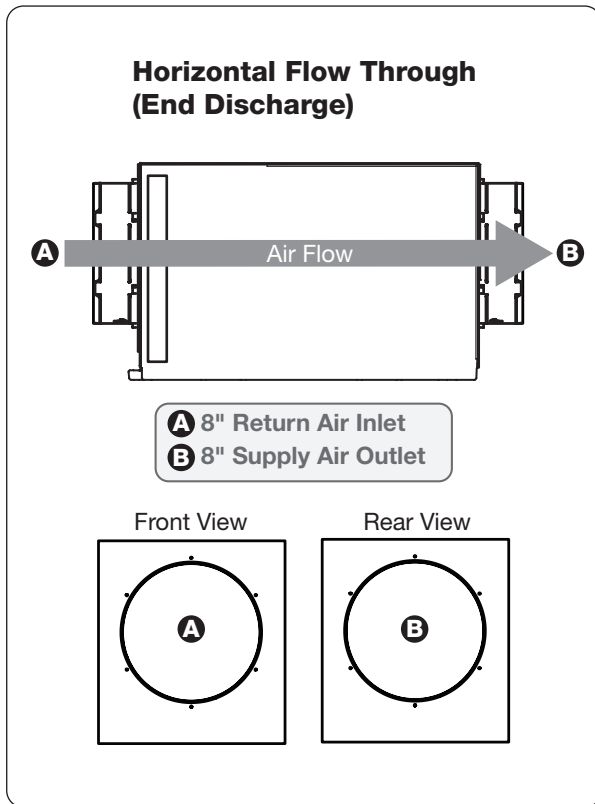

ELECTRICAL REQUIREMENTS

The EDHUM070H plugs into a common grounded 115VAC outlet. The device draws 5.1 Amps at 80°F and 60% RH. Locate the dehumidifier in an area where the cord's length (9') easily reaches a 115 VAC electrical outlet with a minimum of 15 Amp circuit capacity. If used in an area that may become wet, a GFCI protected circuit is recommended. Consult local electrical codes for any further information.

There are multiple control devices that can be used with EDHUM070H. The controls are to be located remotely from the dehumidifier and placed in the space to be conditioned. Low voltage (24 Volt) controls can be used with the EDHUM070H and MUST be connected with low voltage (18-22 gauge) thermostat wire.

⚠ WARNING!

THE REMOTE CONTROLS OF THE EDHUM070H ARE POWERED BY A LOW VOLTAGE CIRCUIT (24VAC) AND MUST NEVER CONTACT OR BE CONNECTED TO A HIGH VOLTAGE CIRCUIT.

⚠ CAUTION!

DO NOT ALLOW THE 24V TERMINAL TO CONTACT THE COM/DMPR TERMINALS ON THE EDHUM070H OR DAMAGE TO THE TRANSFORMER WILL RESULT.

⚠ CAUTION!

SOME OF THE SCREWS TERMINALS ON THE EDHUM070H MAY NOT BE USED WITH CERTAIN CONTROLS AND SHOULD BE LEFT UNCONNECTED.

Electrical Precautions

- Do not install the control where it may not accurately sense the relative humidity such as near HVAC supply registers, near exterior doors, on an outside wall, near a window, or near a water source.
- The screw terminals on the EDHUM070H and the control are labeled to prevent confusion.
- Be sure to consult the electrical schematic in the CONTROLS Section (page 12) of this manual or inside the access panel of the EDHUM070H before making control connections.

Wiring Schematic

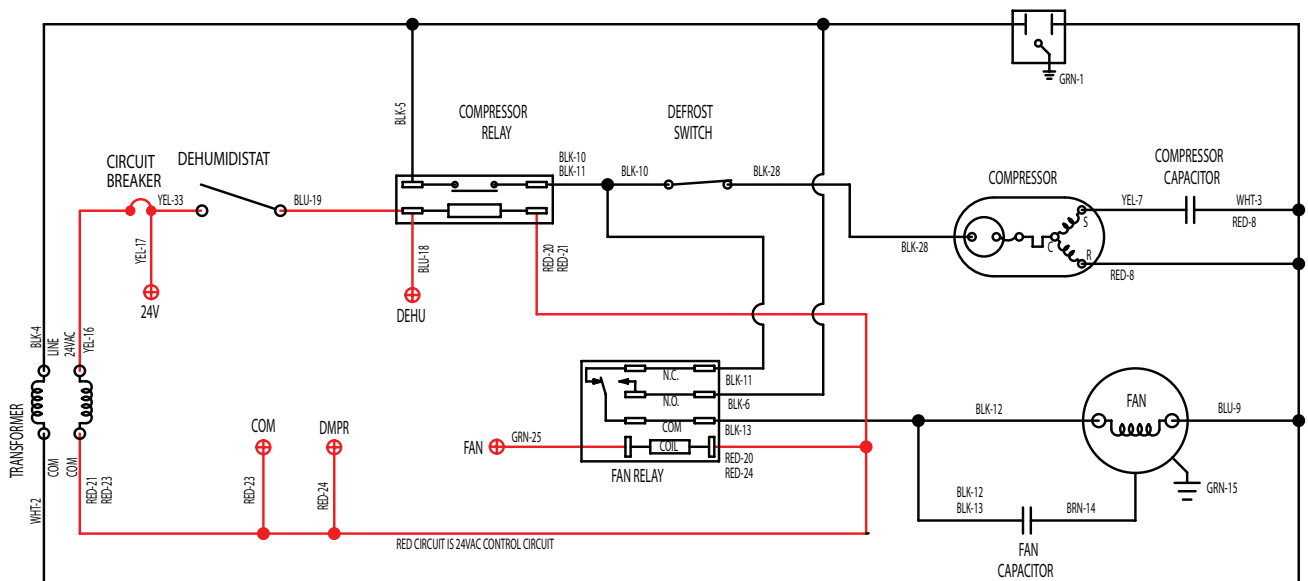

DRAIN INSTALLATION

The EDHUM070H generates condensate.

Place a secondary drain pan with a float switch under the dehumidifier if it is suspended above a finished area or above an area where water leakage could cause damage.

A drain trap is required for the dehumidifier to run properly. Install a 3/4" threaded male NPT adapter to the drain pan. Install a drain pipe assembly utilizing 3/4" PVC pipe to transport the condensate to a drain. Pitch of drain should be 1" per 10'.

An optional condensate pump kit is available for use with the EDHUM070H and may be installed if lift is required to dispose of condensate. Condensate is automatically pumped to a remote location when the water level in the pump's reservoir rises to close the float switch.

The pump also contains a safety float switch. The white leads from this switch extend from beneath the pump cover. This switch should be installed in series with the field wire that connects to the common lead from the EDHUM070H to the control panel. If the pump fails, this switch opens the common control circuit and stops water production before the reservoir overflows. Contact a qualified electrician to install the safety float switch to the EDHUM070H dehumidifier.

Note: An optional condensate pump kit can be purchased from a local dealer or online.

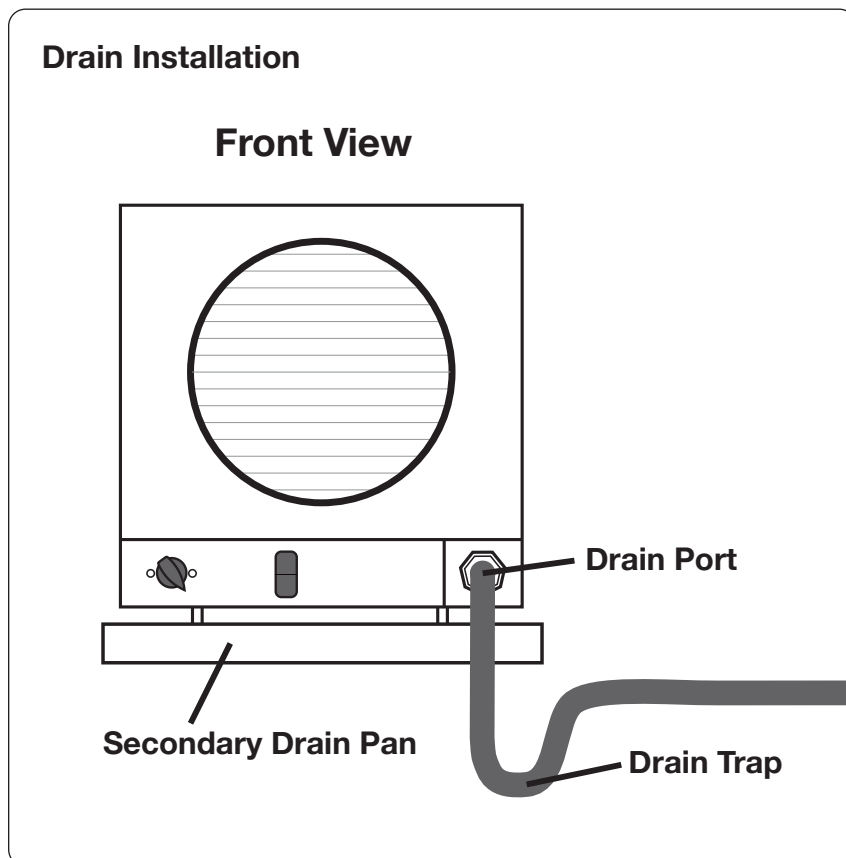

DUCTING TO HVAC SYSTEMS

The recommended installation creates a separate return for the EDHUM070H in a central area of the structure. Duct the supply of the unit to the air supply of the existing HVAC system. Connect an insulated duct from outside to provide fresh make-up air (optional).

⚠ CAUTION!

DO NOT CONNECT WITH A STATIC PRESSURE GREATER THAN OR EQUAL TO +0.5 WG. CONTACT TECHNICAL SUPPORT AT (800) 533-7533 FOR ADDITIONAL DETAILS.

Ducting Considerations:

- All flexible ducting connected to the EDHUM070H should be UL listed.
- A short piece of flexible ducting on all EDHUM070H duct connections is recommended to reduce noise and vibration transmitted to rigid ductwork in the structure.
- Use a minimum 8" diameter round or equivalent rectangular duct for total duct lengths of up to 25'. Use a minimum 10" diameter or equivalent for longer lengths.
- Grills or diffusers on the duct ends must not excessively restrict airflow.
- A length of 8" or more of insulated flex duct or any other vibration isolating material on the outlet of the EDHUM070H will reduce air noise from the blower.
- Effective dehumidification may require that ducting be branched to isolated, stagnant air flow areas. When ducting to two or three areas, use 6" or larger diameter branch ducting. When ducting to four or more areas, use 4"-6" or larger diameter branch ducting. Provisions must be made to provide airflow from supply locations to the central return location. Proper air distribution is important to ensure even humidity control and heat distribution throughout the structure.
- DO NOT locate the return in a bathroom or a kitchen.

DUCTING TO HVAC SYSTEMS

Recommended HVAC System Installation

The recommended installation draws air from a dedicated indoor air return and ducts the supply of the dehumidifier to the air supply of the existing HVAC system. Utilize the optional fresh air ventilation duct to provide outside air.

- Install a dedicated 8" air return for the EDHUM070H from a central area of the structure.
- Duct the supply of the EDHUM070H to the supply of the existing HVAC system with a backdraft damper.
- If the existing system has multiple returns, instead of installing a dedicated return to the EDHUM070H, it is possible to select one to disconnect from the existing HVAC system and use it for the dedicated EDHUM070H return. Select a return from a central location in the house that is always open to the rest of the structure. DO NOT use a return from a room where doors are kept closed.
- DO NOT locate return in a bathroom or kitchen.
- Control should be located remotely from the dehumidifier and placed in a central location.

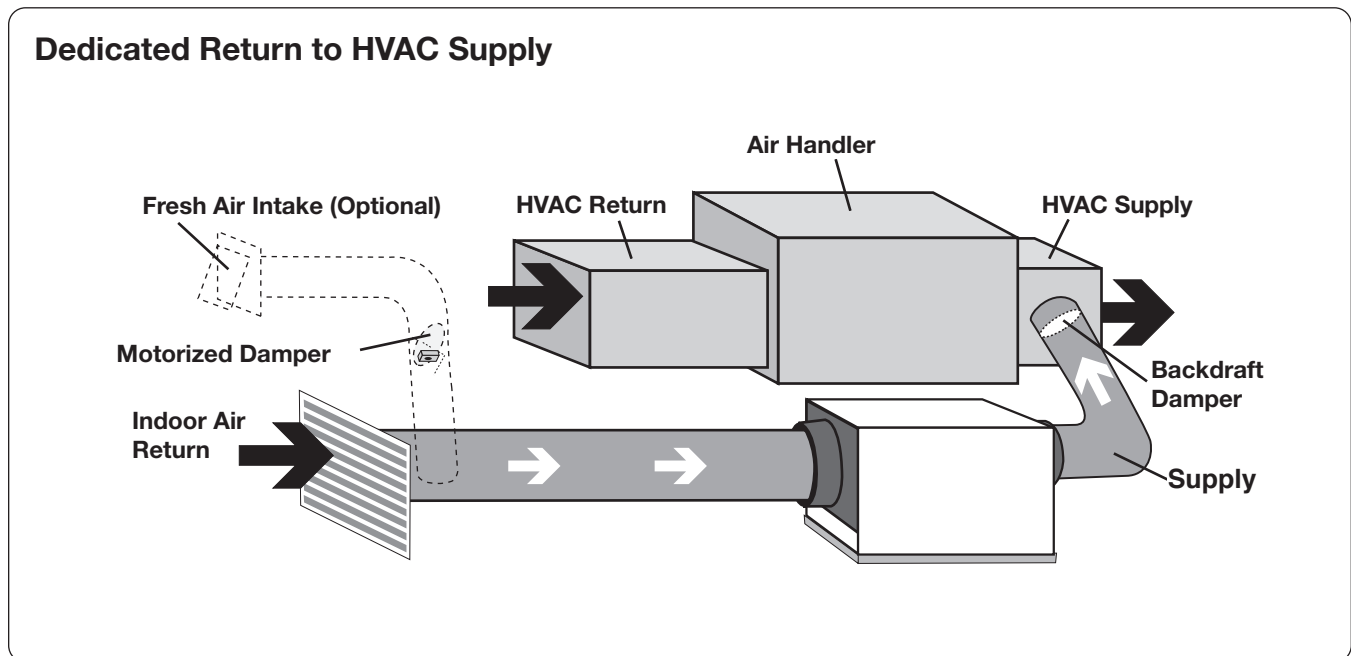

FRESH AIR VENTILATION

Fresh air ventilation is optional.

Fresh air may be brought into the structure by connecting an insulated duct from outside the structure to a tee located in the inlet duct of the EDHUM070H. A ventilation control is needed to program the time and frequency that the unit introduces outside air. The time and frequency of ventilation should be based on the size and occupancy of the residence.

- The 6" fresh air ventilation duct should tee into the 8" round collar on the front of the EDHUM070H.
- An insulated 6" diameter duct can provide up to 55 CFM of outside air.
- Performance of the EDHUM070H can be impacted by inside and outside air conditions.
- When a 6" motorized damper is used, a digital control is required.
- It may be necessary to use 8" duct work if additional fresh air is required.
- In cold climates or at times when the dew point is low, ventilation can be used to dehumidify the structure, making the EDHUM070H capable of year-round drying.

Fresh Air Ventilation With Dehumidifier Off and Fan Only Operation

Outside air mixes with return air prior to beginning the dehumidification process. Outside and inside temperature and relative humidity will impact the combined outlet air conditions.

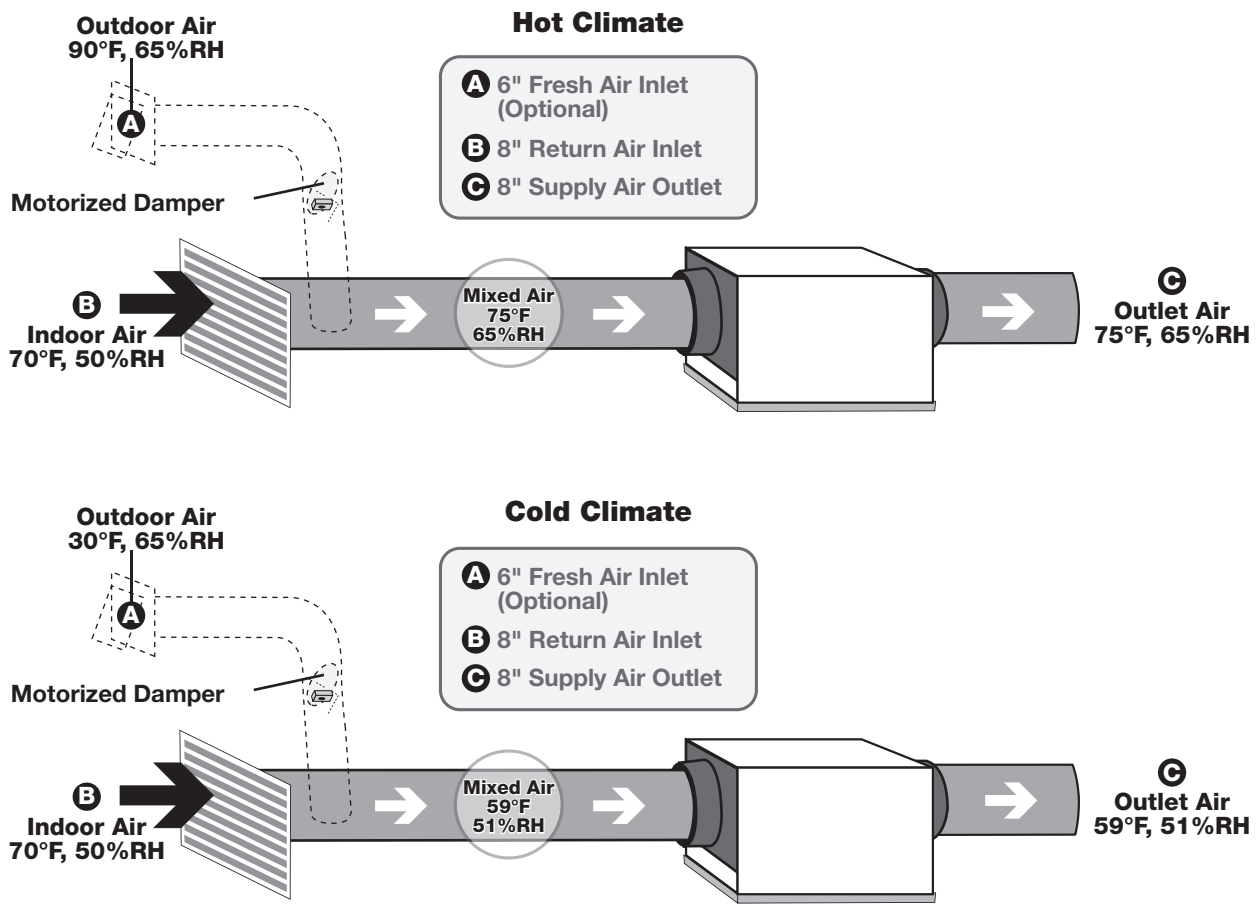

FRESH AIR VENTILATION

Determine Ventilation Requirements

The MINIMUM ventilation requirement is calculated using ASHRAE 62.2-2016. Use one or both of the options below to determine your ventilation requirement. Follow all local and national building and safety codes.

Option 1: Calculating Airflow Requirement Using ASHRAE 62.2-2016 Airflow Equation

ASHRAE Airflow in CFM = [House Area in Sq.Ft. x 0.03] + [(Number of Bedrooms + 1) x 7.5]

NOTE: Use 'Number of Bedrooms + 1' or 'Number of Occupants', whichever is larger.

Example 1: Number of Bedrooms + 1

1800 square foot house with 3 bedrooms, 4 occupants = [1800 X 0.03] + [(3+1) X 7.5] = 84 CFM

Example 2: Number of Occupants

1800 square foot house with 3 bedrooms, 5 occupants = [1800 X 0.03] + [5 X 7.5] = 91.5 CFM

Record the required CFM _____

Option 2: Calculating Airflow Requirement Using Table 4.1 from ASHRAE 62.2-2019

Ventilation Air Requirements, CFM

Floor Area (ft ²)	Number of Bedrooms				
	1	2	3	4	5
< 500	30	38	45	53	60
501 - 1000	45	53	60	68	75
1001 - 1500	60	68	75	83	90
1501 - 2000	75	83	90	98	105
2001 - 2500	90	98	105	113	120
2501 - 3000	105	113	120	128	135
3001 - 3500	120	128	135	143	150
3501 - 4000	135	143	150	158	165
4001 - 4500	150	158	165	173	180
4501 - 5000	165	173	180	188	195

Table 4.1 from ASHRAE 62.2-2019

Record the required CFM _____

CONTROLS

A control can be used with the EDHUM070H. Santa Fe offers the DEH 3000 proprietary control. The DEH 3000 monitors and controls relative humidity and proper ventilation levels in their home. This control is also available with a remote sensing option. The EDHUM070H features a built-in dehumidistat control as well as the ability to wire a remote mounted control to the unit. If the EDHUM070H is located outside of the area where humidity control is desired, consider using a remote wired humidity controller that is located in the area where humidity control is desired. If using the built-in dehumidistat to control the unit, locate the control in an area where it can accurately sense the humidity of the area where humidity control is desired. If the EDHUM070H is located in the area where humidity control is desired, consider using the built-in control. Adjust the humidity control so that the unit maintains the desired level of humidity.

Note: The DEH 3000 is sold separately and can be purchased online or through your local dealer. Other thermostats are compatible with the EDHUM070H.

Wiring Controls

⚠ CAUTION!

DO NOT ALLOW THE 24V TERMINAL FROM THE EDHUM070H TO CONTACT THE COM TERMINAL ON THE EDHUM070H OR DAMAGE TO THE TRANSFORMERS WILL RESULT.

Circuit Breaker

To prevent damage to the 24 volt control transformer, the EDHUM070H comes with a resettable circuit breaker. Check wiring for any electrical short and repair before resetting breaker. Resetting the circuit breaker without correcting the electrical short may result in transformer damage. Be sure to check the electrical schematic in this manual or inside the access panel of the EDHUM070H before making any control connections. The reset button for the circuit breaker can be found on the back of the unit.

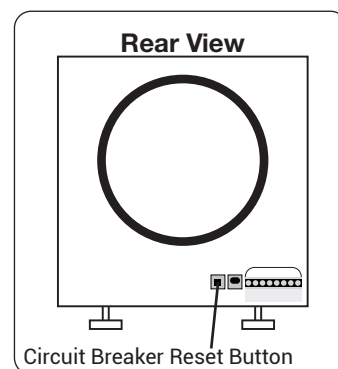

Control Connections

The control and the EDHUM070H are labeled to prevent confusion. Depending on the control, some of the screw terminals on the EDHUM070H may not be used. Be sure to consult the electrical schematic in this manual or inside the access panel of the EDHUM070H before making control connections.

A low voltage control must be used with the EDHUM070H.

Terminal Block Control Operation:

COM	24VAC Power Transformer Neutral Side
FAN	Fan Control
24V	Transformer High Side
DEHU	Dehumidification (Fan and Compressor) Control
DMPR	24VAC Power Transformer Neutral Side
*	Spare Terminal (Open)

Between the COM lead and the 24V TERMINAL is a 40VA transformer. This low voltage power source powers the relay coils which control the fan and compressors. This 24VAC transformer can also be used to power HVAC accessories external to the dehumidifier.

Compressor ON / Fan ON	Make contact between 24V and DEHU terminals
Compressor OFF / Fan ON	Make contact between 24V and FAN terminals
Power HVAC Accessory	Connect the accessory to the DMPR and 24V terminals

NOTE: 18 gauge wire needed between the EDHUM070H dehumidifier and the external control.

AIR FILTRATION

The EDHUM070H is equipped with a MERV-13 (Dimensions: 0.75" x 9.00" x 11.38") air filter. The filter should be checked and replaced every three to six months. Operating the unit with a dirty filter will reduce dehumidifier capacity and efficiency.

DO NOT operate the unit without the recommended filter. Filter non-compliance voids the product warranty.

⚠ CAUTION!

MAKE SURE UNIT IS OFF BEFORE CHANGING THE FILTER.

Changing the Filter

For greatest filtration and efficiency of the EDHUM070H, it is recommended the air filter be replaced every three to six months with a MERV-13 rated filter.

Step 1: Remove the filter door from one side of the EDHUM070H by pushing the snap button in and gently pulling the door away from the unit. Then pull up to disengage the door from the slot.

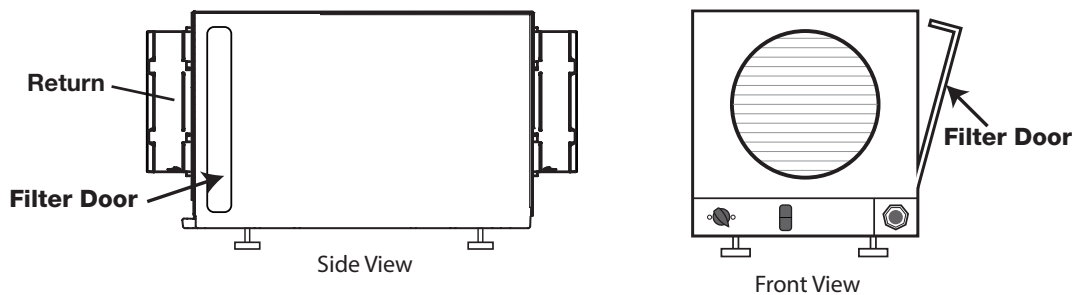

Step 2: Remove the filter by gently pulling straight out of the unit. Insert new filter by gently pushing it straight into the unit. Make sure the AIR FLOW arrow on the filter is pointing into the unit.

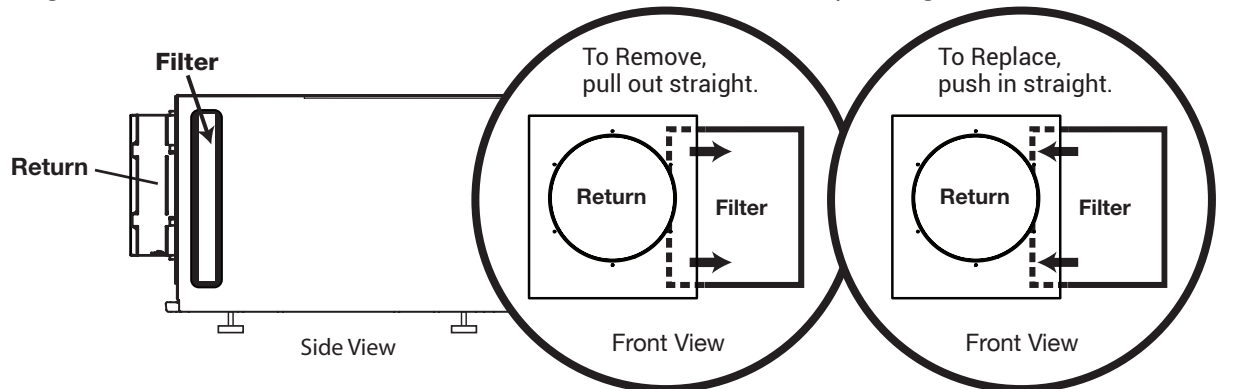

Step 3: Replace filter door ensuring the opening is fully covered.

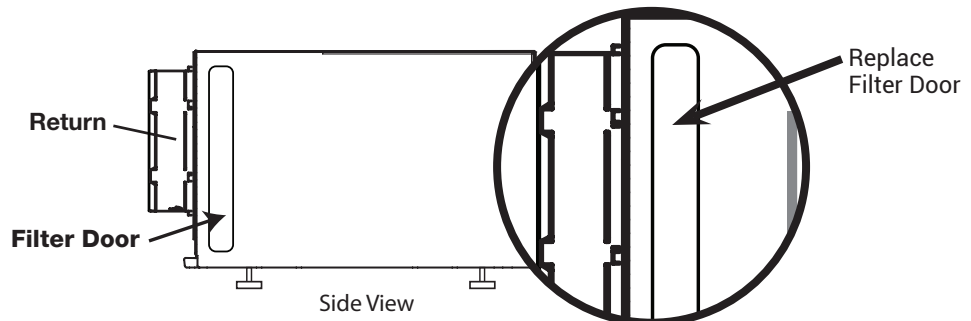

AIR FILTRATION

MERV Rating Chart

Standard 52.5 Minimum Efficiency Reporting Value	Dust Spot Efficiency	Arrestance	Typical Controlled Contaminant	Typical Applications and Limitations	Typical Air Filter/Cleaner Type
20	n/a	n/a	< 0.30 pm Particle Size	Cleanrooms	≥99.999% eff. On .10-.20 pm Particles
19	n/a	n/a	Virus (unattached)	Radioactive Materials	Particulates
18	n/a	n/a	Carbon Dust	Pharmaceutical Man.	Particulates
17	n/a	n/a	All Combustion Smoke	Carcinogenetic Materials	≥99.97% eff. On .30 pm Particles
16	n/a	n/a	.30-1.0 pm Particle Size	General Surgery	Bag Filter - Nonsupported
15	>95%	n/a	All Bacteria	Hospital Inpatient Care	microfine fiberglass or synthetic media, 12-36 in. deep, 6-12 pockets.
14	90-95%	>98%	Most Tobacco Smoke	Smoking Lounges	Box Filter - Rigid Style Cartridge Filters 6 to 12" deep may use lofted or paper media.
13	89-90%	>98%	Proplet Nuceli (Sneeze)	Superior Commercial Buildings	
12	70-75%	>95%	1.0-3.0 pm Particle Size Legionella	Superior Residential	Bag Filter - Nonsupported microfine fiberglass or synthetic media, 12-36 in. deep, 6-12 pockets.
11	60-65%	>95%	Humidifier Dust Lead Dust	Better Commercial Buildings	
10	50-55%	>95%	Milled Flour Auto Emissions	Hospital Laboratories	Box Filter - Rigid Style Cartridge Filters 6 to 12" deep may use lofted or paper media.
9	40-45%	>90%	Welding Fumes		
8	30-35%	>90%	3.0-10.0 pm Particle Size	Commercial Buildings	Pleated Filters - Disposable, extended surface area, thick with cotton-polyester blend media, cardboard frame.
7	25-30%	>90%	Mold Spores Hair Spray	Better Residential	
6	<20%	85-90%	Fabric Protector Dusting Aids	Industrial Workplace	Cartridge Filters - Graded density viscous coated cube or pocket filters, synthetic media.
5	<20%	80-85%	Cement Dust Pudding Mix	Paint Booth Inlet	Throwaway - Disposable synthetic panel filter.
4	<20%	75-80%	>10.0 pm Particle Size	Minimal Filtration	Throwaway - Disposable fiberglass or synthetic panel filter.
3	<20%	70-75%	Pollen Dust Mites	Residential	Washable - Aluminum Mesh.
2	<20%	65-70%	Sanding Dust Spray Paint Dust		
1	<20%	<65%	Textile Fibers Carpet Fibers	Window A/C Units	Electrostatic - Self charging woven panel filter.

Table Data Source: United States Environmental Protection Agency

SERVICE

Troubleshooting

⚠ CAUTION!

TROUBLESHOOTING SHOULD BE PERFORMED BY A QUALIFIED HVAC TECHNICIAN.

Symptom	Possible Reason	Troubleshooting Procedure
Neither fan nor compressor running. Dehumidification is being called for.	<ol style="list-style-type: none"> 1. Dehumidifier unplugged or no power to outlet. 2. Humidity control set too high. 3. Loose connection in internal or control wiring. 4. Defective compressor relay. 5. Defective control transformer. 	<div style="border: 1px solid black; padding: 5px; margin-bottom: 10px;"> <p>⚠ WARNING!</p> <p>ELECTRICAL SHOCK HAZARD: ELECTRICAL POWER MUST BE PRESENT TO PERFORM SOME TESTS. THESE TESTS SHOULD BE PERFORMED BY A QUALIFIED SERVICE PERSON.</p> </div> <p>Troubleshooting Procedure for Control Related Issues</p> <p>This method of diagnosis will test the 3 main components of the control circuit individually to indicate any potential problems. This is to be used when the control will not activate the main unit.</p> <ol style="list-style-type: none"> 1. Detach field control wiring connections from the terminals on the main unit. 2. Connect the 24V and FAN terminals together; only the fan should run. Disconnect the terminals. 3. Connect the 24V and DEHU terminals together; fan and compressor should run. Disconnect the terminals. 4. If this test works, the main unit is working correctly from a control standpoint. 5. Reconnect field control wiring to the terminals on the main unit. 6. Remove the control panel cover and detach the field wiring from the control connections. 7. Connect the 24V and FAN terminals together; only the fan should run. Disconnect the terminals. 8. Connect the 24V and DEHU terminals together; fan and compressor should run. Disconnect the terminals. 9. If this test works, then the field control wiring is ok. 10. If the problem persists, then the control is most likely faulty.
Compressor is not running. Dehumidification is being called for. Fan is running.	<ol style="list-style-type: none"> 1. Defective compressor run capacitor. 2. Loose connection in compressor circuit. 3. Defective compressor overload. 4. Defective compressor. 5. Defrost thermostat open. 	
Compressor cycles on and off. Dehumidification is being called for.	<ol style="list-style-type: none"> 1. Low ambient temperature and/or humidity causing unit to cycle through defrost mode. 2. Defective compressor overload. 3. Defective compressor. 4. Defrost thermostat defective. 5. Dirty air filter(s) or air flow restricted. 6. Defective fan or relay. 	
Fan is not running. Dehumidification or fan is being called for.	<ol style="list-style-type: none"> 1. Loose connection in fan circuit. 2. Obstruction prevents fan impeller rotation. 3. Defective fan. 4. Defective fan relay. 	

SERVICE

Troubleshooting (Continued)

Symptom	Possible Reason	Troubleshooting Procedure
Low dehumidification capacity (evaporator is frosted continuously). Dehumidification is being called for.	<ol style="list-style-type: none"> 1. Defrost thermostat loose or defective. 2. Low refrigerant charge. 3. Dirty air filter(s) or air flow restricted. 4. Excessively restrictive ducting connected to unit. 	<div style="background-color: #333; color: white; padding: 5px; margin-bottom: 10px;"> ⚠ WARNING! </div> <p>ELECTRICAL SHOCK HAZARD: ELECTRICAL POWER MUST BE PRESENT TO PERFORM SOME TESTS. THESE TESTS SHOULD BE PERFORMED BY A QUALIFIED SERVICE PERSON.</p> <p>Troubleshooting Procedure for Performance Related Issues This method of diagnosis is used to function check the internal components in the dehumidifier. This is to be used when a performance issue is suspected.</p> <ol style="list-style-type: none"> 1. Set the humidity controller all the way to the most humid setting or off position – Did the unit shut off? 2. If yes, turn the fan setting to the ON position – does the fan start? 3. If fan starts, leave in the fan ON position and set the humidity all the way to driest setting. May have to wait 5 minutes for the compressor to start. 4. Listen for a distinct buzzing/humming sound of a compressor starting up – do you hear this noise? 5. If compressor is running and continues to run, after about 15 minutes you should feel a slight increase in air temperature being discharged out of the discharge air side of the unit. 6. If so, depending on your environmental conditions (temp/Rh%), you should see some water production out of the hose within 30 minutes or so. <i>(Note: If the room temperature is 55 degrees or below and/or in area of low relative humidity, the dehumidifier will produce little to no water.)</i> 7. Collecting the water removed in a 24 hour period will give a measurement of performance.
No ventilation. Ventilation is being called for.	<ol style="list-style-type: none"> 1. Loose connection in ventilation control circuit. 2. Loose connection in damper power circuit. 3. Defective fresh air damper. 	
Dehumidifier removes some water, but not as much as expected.	<ol style="list-style-type: none"> 1. Air temperature and/or humidity have dropped. 2. Humidity meter and or thermometer used are out of calibration. 3. Unit has entered defrost cycle. 4. Dirty air filter(s) or air flow is restricted. 5. Defective defrost thermostat. 6. Low refrigerant charge. 7. Air leak such as loose cover or ducting leaks. 8. Defective compressor. 9. Restrictive ducting. 	

Refrigerant Charging

⚠ WARNING!

SERVICING THE EDHUM070H WITH ITS HIGH PRESSURE REFRIGERANT SYSTEM AND HIGH VOLTAGE CIRCUITRY PRESENTS A HEALTH HAZARD WHICH COULD RESULT IN DEATH, SERIOUS BODILY INJURY, AND/OR PROPERTY DAMAGE. SERVICE MUST BE PERFORMED BY A QUALIFIED SERVICE TECHNICIAN.

If the refrigerant charge is lost due to service or a leak, the leak should be repaired and a new charge must be accurately weighed in. If any of the old charge is left in the system, it must be recovered before weighing in the new charge. Refer to the unit nameplate for the correct charge weight and refrigerant type.

WARRANTY

Limited Warranty

Subject to the terms and conditions of this limited warranty, Trane U.S., Inc. ("Company") extends a limited warranty to the original purchaser only for parts (but not labor) replaced as a result of manufacturing defects for the product(s) identified in **Tables 1, 1A** attached hereto ("Products") that are installed in residential/multi-family application (personal, family, or household purposes) and subject to normal use and maintenance in the United States and Canada. All repairs of Products covered under this limited warranty must be made with authorized service parts and by a licensed service provider. Additionally, commercial applications are treated differently under this limited warranty as stated in **Tables 1, 1A** attached hereto. "Commercial applications" shall mean any application other than for personal, family or household use.

This limited warranty applies to Products manufactured on or after January 1, 2021. Please read it in its entirety.

TERM: Tables 1, 1A (attached hereto) contain the Limited Warranty Period for the original purchaser:

- For most installed Products including, but not limited to, Products installed in a builder's model home, the Commencement Date shall be the date that the original installation is complete and all Product start-up procedures have been properly completed and recorded on the installer's invoice, which includes all model and serial numbers of the installed Product(s). If the installation and start-up date was not recorded on the installer's invoice the Commencement Date shall be sixty (60) days after the factory manufacture date, which is determined by the Product serial number.
- If a Product is installed in a newly constructed home, the Commencement Date is the date the original purchaser purchased the residence from the builder. Proof of Product purchase, installation, and/or closing date of the residence may be required to confirm the Commencement Date.
- The installation of Product replacement parts under this limited warranty shall not extend the original warranty period. The warranty period for any Product part replaced under this limited warranty is the applicable warranty period remaining under the original Product warranty.
- If the original purchaser sells the home within five (5) years of the Commencement Date, this limited warranty shall apply to the subsequent purchaser(s) for all parts except the heat exchanger until five (5) years from the Commencement Date and for the heat exchanger until twenty (20) years from the Commence Date.

How to Obtain Service: To locate a service provider in your area, who will provide service under this limited warranty, for Trane Product(s) please visit: www.trane.com or call 877-263-7578, for American Standard Product(s) please visit: www.americanstandardair.com or call 855-480-2741. Company may request proof of Product purchase and/or installation, including installation address, in order to provide replacement part(s) under this limited warranty.

What Company Will Do: As the Company's only responsibility and the purchaser's only remedy under this limited warranty, Company will furnish a replacement part for installation by licensed HVAC service provider, without charge for the part only, to replace any Product part that fails due to a manufacturing defect under normal use and maintenance. The purchaser must pay for any and all shipping and handling charges and other costs of warranty service for the replacement part. If the Product part is not available, the Company will, at its option, provide a free suitable part or provide a credit in the amount of the then factory selling price for a new suitable substitute part to be used by the purchaser towards the retail purchase price of a new Company product. Any new Product purchase shall be at purchaser's sole cost and expense including, but not limited to, all shipping, removal, and installation costs and expenses.

Eligibility Requirements: The following items are required in order for the Product(s) to be covered under this limited warranty:

- The Product(s) must be in the same location where they were originally installed.
- The Product(s) must be properly installed, operated, and maintained by a licensed HVAC service provider in accordance with the Product specifications or installation, operation, and maintenance instructions provided by Company with each Product. Failure to conform to such specification and/or installation, operation, and maintenance instructions shall void this limited warranty.
- Company may request written documentation showing the proper preventative maintenance.
- All Product parts replaced by Company under this limited warranty must be given to the servicing provider for return to Company.
- Air handler, air conditioner, heat pumps, cased or uncased coils, stand-alone furnaces, and packaged units must be part of an Air Conditioning, Heating, and Refrigeration Institute rated and matched system or a specification in a Company provided bulletin or otherwise approved in writing by a Company authorized representative.
- All claims under this limited warranty must be filed within 90 days of failure date.

Exclusions: Following are not covered by this limited warranty:

- Labor costs, including, but not limited to, costs for diagnostic calls or the removal and reinstallation of Products and/or Product parts.
- Shipping and freight expenses required to ship Product replacement parts.
- Failures, defects or damage (including, but not limited to, any loss of data or property) caused by:
 - o Any third party product, service, or system connected or used in conjunction with the Product(s);
 - o Any use that is not designed or intended for the Product(s);
 - o Modification, alteration, abuse, misuse, negligence, or accident;
 - o Improper storage, installation, maintenance, or operation including, but not limited to, operation of electrical equipment at voltages other than that the range specified on the Product nameplate;
 - o Any use in violation of the written instructions or specifications provided by Company;
 - o Any acts of God including, but not limited to, fire, water, storms, lightning, or earthquakes, or any theft or riots;
 - o A corrosive atmosphere or contact with corrosive material such as, but not limited to, chlorine, fluorine, salt, sulfur, recycled waste water, urine, fertilizers, rust, or other damaging substances or chemicals.
- Products purchased direct including, but not limited to, Internet, or auction purchases and purchases made on an uninstalled basis.
- Cabinets or cabinet pieces that do not affect Product performance, air filters, refrigerant, refrigerant line sets, belts, wiring, fuses, surge protection devices, non-factory installed driers, and Product accessories.
- Increased utility usage costs.
- Replacement parts required to convert Product(s) from R-410A refrigerant to any other refrigerant.
- Use of alternate, contaminated, counterfeit, non-manufacture approved refrigerants, and/or non-approved refrigerant additives including, but not limited to, dyes will void this warranty.
- Liquid line filter drier must be replaced when a compressor replacement is necessary. A suction line filter drier must be added for compressor failures defined as burnouts and failure to do so will void this limited warranty.

GW-AHDL-2101A

WARRANTY

Additional Terms: THIS LIMITED WARRANTY AND LIABILITY SET FORTH HEREIN ARE IN LIEU OF ALL OTHER WARRANTIES AND LIABILITIES, WHETHER IN CONTRACT OR IN NEGLIGENCE, EXPRESS OR IMPLIED, IN LAW OR IN FACT. THE IMPLIED WARRANTIES OF MERCHANTABILITY AND FITNESS FOR A PARTICULAR PURPOSE ARE LIMITED TO THE DURATION OF THE APPLICABLE PRODUCT WARRANTY. COMPANY DOES NOT AUTHORIZE ANY PERSON TO CREATE FOR IT ANY OBLIGATION OR LIABILITY IN CONNECTION WITH THE PRODUCT(S). NOTWITHSTANDING ANYTHING IN THIS LIMITED WARRANTY TO THE CONTRARY, COMPANY SHALL NOT BE LIABLE FOR ANY INCIDENTAL, CONSEQUENTIAL, INDIRECT, SPECIAL, AND/OR PUNITIVE DAMAGES, WHETHER BASED ON CONTRACT, WARRANTY, TORT, (INCLUDING, BUT NOT LIMITED TO, STRICT LIABILITY OR NEGLIGENCE), PATENT INFRINGEMENT, OR OTHERWISE, EVEN IF ADVISED OF THE POSSIBILITY OF SUCH DAMAGES. COMPANY'S MAXIMUM LIABILITY HEREUNDER IS LIMITED TO THE ORIGINAL PURCHASE PRICE FOR THE PRODUCT(S).

No action arising out of any claimed breach of this limited warranty may be brought by the purchaser more than one (1) year after the cause of action has arisen.

This limited warranty gives you specific legal rights, and you also have other rights that vary from state to state. If this Product is considered a consumer product, please be advised that some state laws do not allow exclusions or limitations on incidental or consequential damages, or limitations on how long a warranty lasts; or how long an implied warranty lasts, so that the above limitations may not apply to you. Refer to your local laws for your specific rights under this limited warranty. If you have any questions regarding this limited warranty, please contact your original installation dealer, or any participating dealer, should your original installation dealer no longer be available.

Customer Relations, PO Box 4419, Bridgeton, MO 63044; Phone 1-800-945-5884
Or visit our website at www.trane.com or www.americanstandardair.com

Table 1: Warranty Time Periods for Trane and American Standard Products applied in residential applications

Air Handlers:

TAM, GAF2, GAM5, GMU, GMV, TEM, TMM
Limited Warranty Period – Original Purchaser
Indoor Coil and Parts – ten (10) years

ACCESSORIES:

Electric Heaters for Multi-Position Air Handlers
BAYEA, BAYEC, BAYHTR15, BAYHTR35, BAYHTRM5
Limited Warranty Period – Original Purchaser: ten (10) years

Optional Accessories for Multi-Position Air Handlers
UVC LIGHTS: BAYUVC
Limited Warranty Period – Original Purchaser: Ballast – ten (10) years, Bulbs – one (1) year

Hydronic Heaters for Multi-Position Air Handlers BAYWA
Limited Warranty Period – Original Purchaser: ten (10) years

Specific Terms for Commercial Applications
Limited Warranty Period: Coil, Parts – one (1) year

Table 1A: Limited Warranty Time Periods for Trane and American Standard Products applied in residential applications

(May be applicable to Air Handler or Furnace Products)

Controls: *CONT102, *CONT103, *CONT202, *CONT203, *CONT302, *CONT303, *CONT401, *CONT402, *CONT624, *CONT724, ZSENS930, TCONT830
Limited Warranty Period – Original Purchaser: five (5) years

Controls: *CONT824, *CONT850, *ZON1050, *ZON1040
Limited Warranty Period – Original Purchaser: ten (10) years

Zoning Products: ZZONEPNLAC52Z, ZZONEEXPAC52Z, ZZSENSAL0400, BAYSEN01ATEMPA, BAY24VRP, ZDAMP RD, ZDAMP SM, ZDAMP BM, ZDAM-PRR
Limited Warranty Period – Original Purchaser: ten (10) years

Humidifiers: *HUMD200, *HUMD300, *HUMD500 and EHUM800
Limited Warranty Period – Original Purchaser: ten (10) years

Energy Recovery Ventilator (EERV): EERV100, EERV200 & EERV300
Limited Warranty Period – Original Purchaser: ten (10) years

Fans And Other Ventilation Products: Ventilator QF130V
Limited Warranty Period – Original Purchaser: five (5) years

Air Cleaners: TFD, AFD & EFD
Limited Warranty Period – Original Purchaser: ten (10) years

*(First digit may be a "T", "E" or an "A")

Dehumidifiers: 70V, 98H, 105XT, SD-12, 100V, 155XT, 205H
Limited Warranty Period: Five (5) Year Functional Parts, Five (5) Year Unit Exchange

*Refrigerant System Failure *Refrigerant System Failure means a failed component in the sealed refrigerant circuit including compressor, coil and related components.

Note: If any part of your Dehumidifier Refrigerant System fails because of a manufacturing defect under normal use and maintenance within the Limited Warranty Period the affected unit will be exchanged. The purchaser must return the affected unit to the place of purchase in exchange for an equal replacement unit. Documentation relating to original owner, purchase date and install location will be required including a service diagnosis of failure. The purchaser is responsible for all costs of warranty service including, but not limited to, any related service labor or diagnosis calls. The purchaser relinquishes all rights to ownership of the returned unit.

Specific Terms For Commercial Applications:
Limited Warranty Period Applies for all controls, zoning products, humidifiers, dehumidifiers and ERV's, Fans and Air Cleaners.
Limited Warranty Period – five (5) years