

INSTALLER'S GUIDE

18-HE128D1-1C-EN

ALL phases of this installation must comply with NATIONAL, STATE AND LOCAL CODES.

Coil TXV Kit:

Fits Coil Models:

4TXC, 4PXC, 4PXA, and A4MX

4AYTXVH4A1830A
4AYTXVH4A3042A
4AYTXVH4A4860A

IMPORTANT— This Document is customer property and is to remain with this unit. Please return to service information pack upon completion of work.

General Information

This TXV kit is intended for use with A4MX, 4TXC, 4PXC, and 4PXA coil families.

This kit may be used to improve efficiency and ratings on the A4MX coils. This kit may also be used to lower the superheat on 4TXC, 4PXC, and 4PXA coils to improve latent capacity in high humidity environments.

NOTE: The TXV type must always match the refrigerant type listed on the name plate of the outside unit.

Kit Identification

Confirm the Coil TXV Kit type is approved to be used with the coil model. See Table 1 to verify proper kit and product model number.

Inspection

Check carefully for any shipping damage. Any damage must be reported to, and claims made against the transportation company immediately. Any missing parts should be reported to your supplier at once and replaced with authorized parts only.

Table 1. Air Conditioning and Heat Pump Systems

ADJUSTABLE R410A TXV KIT	4PXC-U & 4PXA:	4PXC-D:	4TXC:	A4MX:
4AYTXVH4A1830A	24	24-30	A002	A1824
4AYTXVH4A3042A	30-42	36-42	A032, B003-C005	B1832, A3036, B3642, C3642, B4248
4AYTXVH4A4860A	48-60	48-60	B006-D010	C4248, D4248, C4260, D4260

Coil TXV Kit Contents

Open and inspect contents for damage or missing items. Each kit contains:

No.	Qty	Description
1*	1	R-410A Expansion Valve
2	1	Hose Clamp
3	3	Teflon® Washer
4	3	Insulation 3.5" x 7"
5	1	Orifice Removal Tool
6	1	Installer's Guide (Not shown)
7*	1	3/4" or 7/8" Vapor Line Adaptor
8*	1	3/8" Liquid Tube Assembly

*See table below for the contents in the respective TXV kit

Adjustable R410A TXV Kit	TXV Part #	Vapor Line Adaptor	Liquid Tube Assy
4AYTXVH4A1830A	P01	3/4"	3/8"
4AYTXVH4A3042A	P02	3/4" and 7/8"	-
4AYTXVH4A4860A	P03	7/8"	-

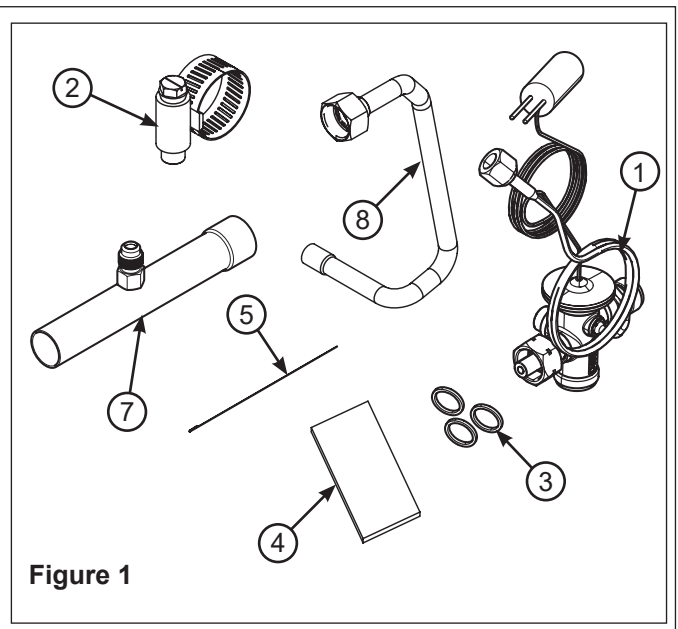

⚠ CAUTION

Do not use adjustable TXV kit with a variable-speed outdoor unit.

⚠ CAUTION

Do not adjust TXV superheat until unit is properly charged. Refer to "Adjusting Superheat" below.

Installation Instructions for Replacing Piston with TXV in Models A4MX

NOTICE

The superheat on these TXV kits is pre-adjusted for A4MX models. No additional adjustment is required for installation.

1. If the coil has been previously installed, recover system charge or "pump-down" system charge into the condensing unit complying with EPA regulations. Un-braze the field lines from the line set of the cased coil.
2. Remove the line set panel and coil panel from the coil (Figure 2).
3. Cut the wire tie around the liquid tube assembly.
4. Using a back-up wrench, loosen the mechanical fittings between the liquid tube assembly and the distributor (Figure 3).

NOTE: If installing TXV Kit on A4MXA1824, discard existing liquid line and install new liquid line provided.

5. Using the orifice removal tool, remove the orifice piston from inside of the distributor (Figure 3). Discard the orifice piston.

IMPORTANT: Proper installation of TXV is critical for preventing leaks. DO NOT oil any threads on TXV, distributor, or liquid line fittings.

6. To install the TXV, install one new Teflon washer over the distributor fitting and the other new Teflon washer over the liquid line fitting (Figure 4). Hand-tighten the adapters to make sure proper mating of threads. Tighten until bodies "bottom" or a definite resistance is felt. Using a back-up wrench, tighten an additional 1/4 turn.
7. Adjust the distributor and TXV as needed to pass the liquid line through the line set panel hole. Do not bend or kink the liquid line.

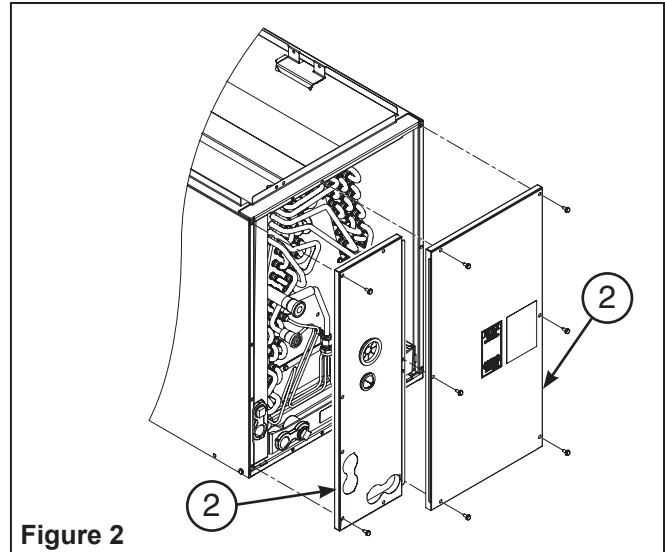

Figure 2

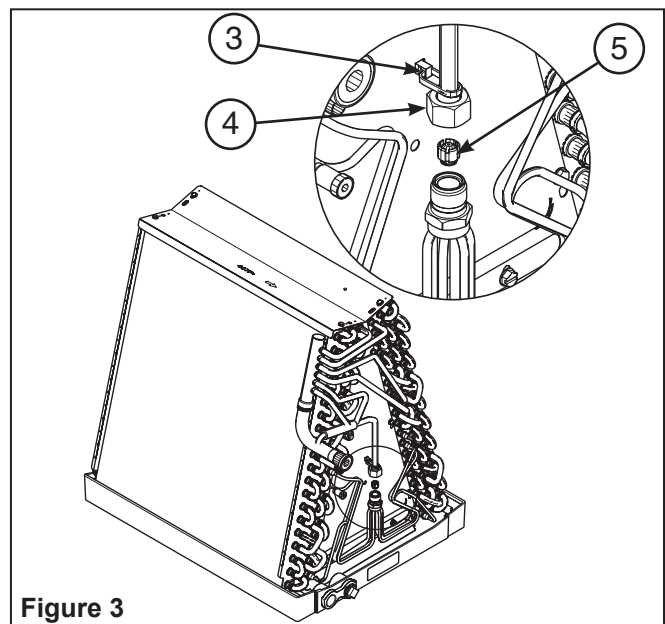

Figure 3

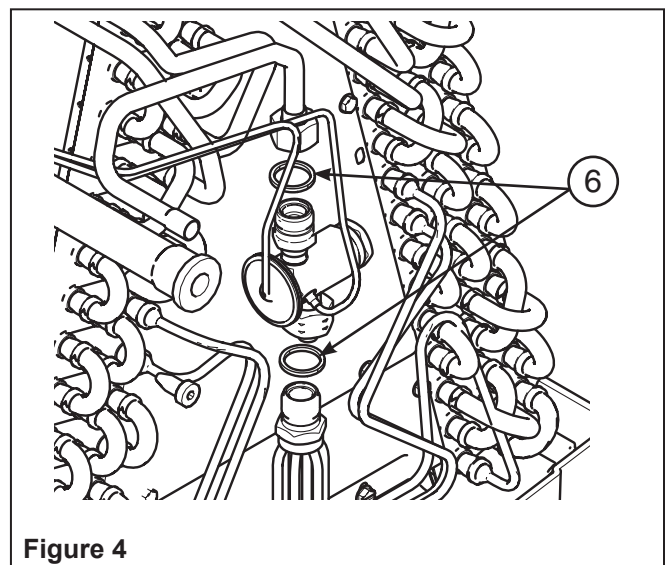

Figure 4

8. Pull the TXV equalizer line through the liquid line opening (smaller opening) on the coil line set panel (Figure 5). The TXV equalizer line must be connected to the vapor line adaptor outside of the unit.
9. Pull the TXV sensing bulb through the liquid line opening (smaller opening) on the coil line set panel (Figure 5). The TXV sensing bulb must be mounted on the vapor line set outside of the unit.
10. To prevent leaks due to corrosion from copper-aluminum interaction, loosely wrap the bulb line, equalizer line and 3/8" liquid line together with provided insulation where they cross the aluminum slab or aluminum tubing inside the cabinet (Figure 5). Make sure that the installed insulation prevents any copper from touching aluminum.
11. Carefully pull the equalizer and sensing bulb lines through the liquid line opening. Ensure these lines do not cover the right-center screw hole on the line set panel to prevent screws from puncturing lines during coil panel installation (Figure 6).
12. Verify that all distributor tubes are positioned within the drain pan perimeter to ensure distributor tubing condensate is collected, then install the coil panel on the cabinet (Figure 6).
13. Before brazing, pull bulb and equalizer lines away from refrigerant lines and wrap them with a wet rag to avoid damaging the TXV during brazing (Figure 7). Wrap the equalizer port on the vapor line adaptor with wet rag to avoid damaging the braze joint.
14. Braze the vapor line adaptor provided onto the coil vapor line (Figure 7).
15. Braze the field lines to the coil liquid line and vapor line adaptor (Figure 7).

IMPORTANT: Proper installation of the sensing bulb is critical to valve performance.

- The TXV bulb capillary tube should not touch any surfaces colder than the vapor line.
- Make sure that the entire length of the bulb is in firm contact with the vapor line.
- Position the bulb on a smooth straight section of the vapor line downstream of the equalizer fitting as illustrated in Figure 8. If the bulb must be mounted vertically, ensure that the bulb tube is pointed upward.
- When the bulb is installed on a horizontal section of the field vapor line, align the bulb at the 10 or 2 o'clock position.

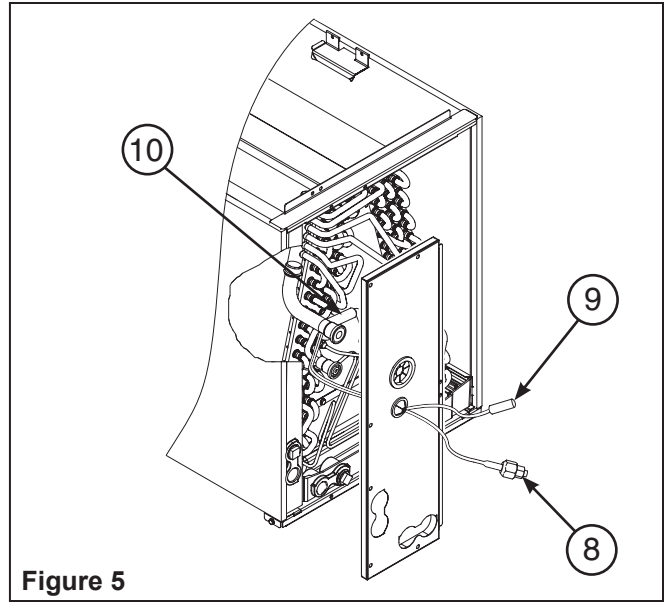

Figure 5

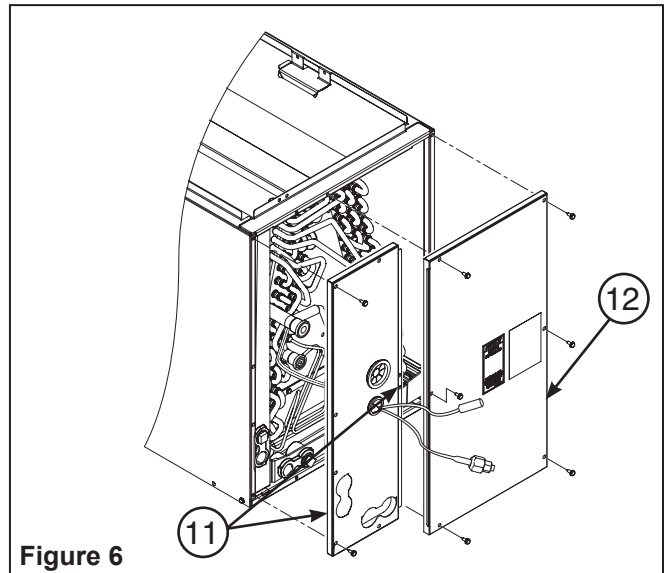

Figure 6

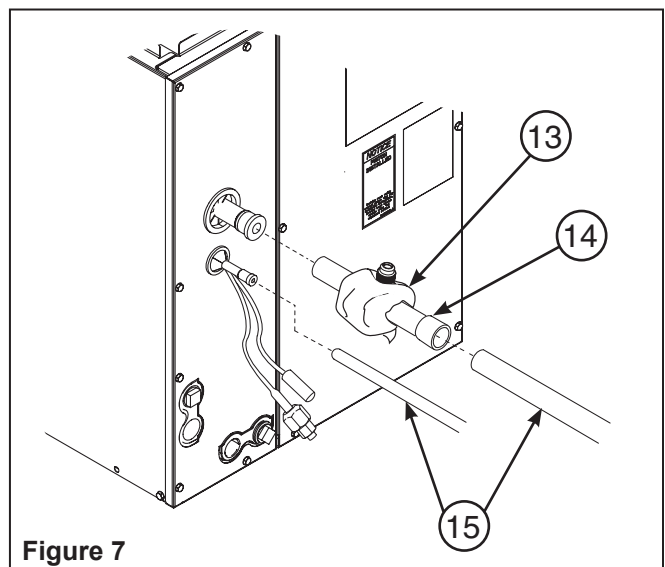

Figure 7

16. Attach the bulb to the vapor line using the supplied hose clamp (Figure 8). The clamp should be “snug” but not “tight” – spec is to torque the hose clamp to 20 ± 5 in-lb. Make sure that the entire length of the bulb is in firm contact with a straight smooth section of the vapor line. Wrap with supplied insulation.
17. Connect the TXV equalizer line to the equalizer fitting. Hand-tighten until flare bottoms. Use a back-up wrench to tighten securely.

IMPORTANT: Replacing the liquid line filter drier is recommended if system has been commissioned. This is not necessary if this kit is being installed on a new system.

18. Pressurize with dry nitrogen and leak test all joints to make sure no leaks exist. Evacuate system to a minimum of 500 microns.
19. Open valves to outdoor unit if pumped-down or charge to a minimum of 50 psig static pressure. Start system and charge to a minimum of 8° F subcooling or Outdoor Unit nameplate subcooling, whichever is higher. Refer to Outdoor Unit nameplate and Installer’s Guide for further information.

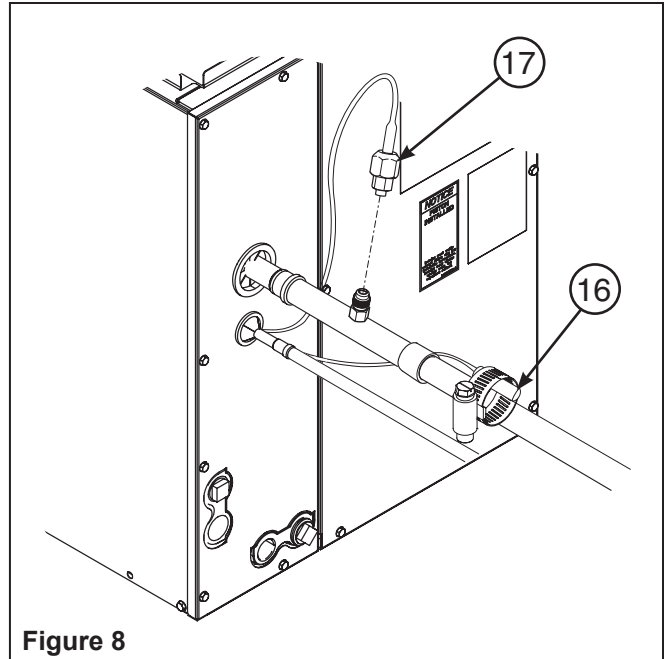

Figure 8

⚠ CAUTION

Do not adjust TXV superheat until unit is properly charged. Refer to “Adjusting Superheat” below.

Installation Instructions for Replacing TXV in Models 4TXC/4PXC/4PXA

1. If the coil has been previously installed, recover system charge or “pump-down” system charge into the condensing unit complying with EPA regulations.
2. Remove the line set panel and coil panel from the coil (Figure 2).
3. Remove the sensing bulb from the vapor line by removing the bulb insulation and hose clamp (Figure 9).
4. Using a back-up wrench, loosen the external equalizing coupling (Figure 9).
5. Cut the wire tie around the TXV body and remove from coil (Figure 9).
6. Using a back-up wrench, loosen the mechanical fittings. Remove the TXV (Figure 9).

IMPORTANT: Proper installation of TXV is critical for preventing leaks. DO NOT oil any threads on TXV, distributor, or liquid line fittings.

- Remove and discard the Teflon washers from the existing flow control assembly.
- Minimize the amount of movement of the aluminum distributor tubes to prevent tube weakening.

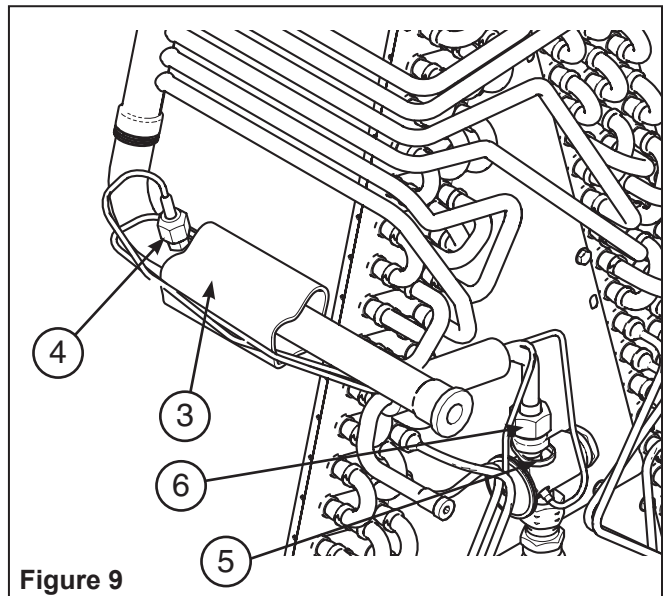
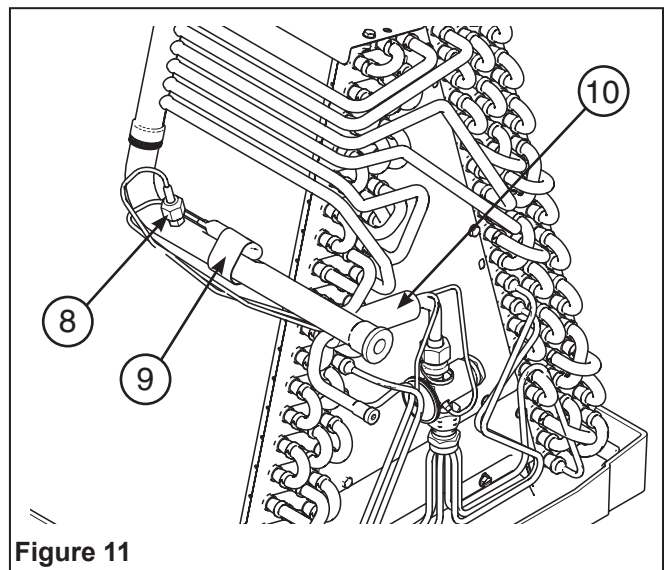
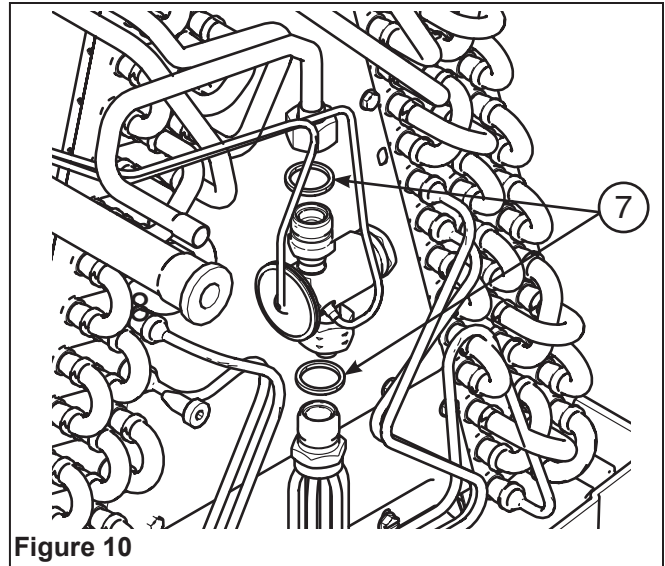

Figure 9

7. To install the TXV, install one new Teflon washer over the distributor fitting and the other new Teflon washer over the liquid line fitting (Figure 10). Hand-tighten the adapters to make sure proper mating of threads. Tighten until bodies “bottom” or a definite resistance is felt. Using a back-up wrench, tighten an additional 1/4 turn.
8. Connect the TXV equalizer line to the equalizer fitting (Figure 11). Hand-tighten until flare bottoms. Use a back-up wrench to tighten securely.
9. Attach the bulb to the vapor line using the supplied hose clamp. The clamp should be “snug” but not “tight” – spec is to torque the hose clamp to 20 ± 5 in-lb. Wrap with supplied insulation. Make sure that the entire length of the bulb is in firm contact with a smooth, straight section of the vapor line. If a bulb indentation is present in line, locate bulb squarely within indentation and do not allow bulb to overhang.
10. To prevent leaks due to corrosion from copper-aluminum interaction, loosely wrap the bulb line and equalizer line and 3/8” liquid line together with provided insulation where they cross the aluminum slab or aluminum tubing inside the cabinet (Figure 11). Make sure that installed insulation prevents any copper from touching aluminum.
11. Verify that all distributor tubes are positioned within the drain pan perimeter to ensure distributor tubing condensate is collected, then install the coil panel on the cabinet.

IMPORTANT: Replacing the liquid line filter drier is recommended if system has been commissioned. This is not necessary if this kit is being installed on a new system.

12. Pressurize with dry nitrogen and leak test all joints to ensure no leaks exist. Evacuate system to a minimum of 500 microns.
13. Open valves to outdoor unit if pumped-down or charge to a minimum of 50 psig static pressure. Start system and charge to a minimum of 8° F subcooling or Outdoor Unit nameplate subcooling, whichever is higher. Refer to Outdoor Unit nameplate and Installer’s Guide for further information.



Adjusting Superheat

NOTE: The coil panel must be installed to prevent inaccurate SH measurement when charging and before any SH adjustment is made.

1. Unit should be charged and running for at least 15 minutes before measuring superheat and adjusting TXV.
2. Remove coil panel to access TXV (Figure 12).
3. Remove adjustment valve cap (Figure 12). Mark the adjustable valve stem and TXV body to indicate the starting position of the valve.
4. Reduce superheat by turning valve counterclockwise a maximum of $\frac{1}{4}$ turn (Figure 12).
5. Reinstall coil panel to prevent air leakage from cabinet. Wait 15 minutes for system stability, then measure superheat.
6. If further adjustment is desired, repeat steps 2 through 4. Adjustment steps may be repeated as needed up to a total of one full turn.
7. Once desired superheat is reached, replace adjustment valve cap and tighten "snug".

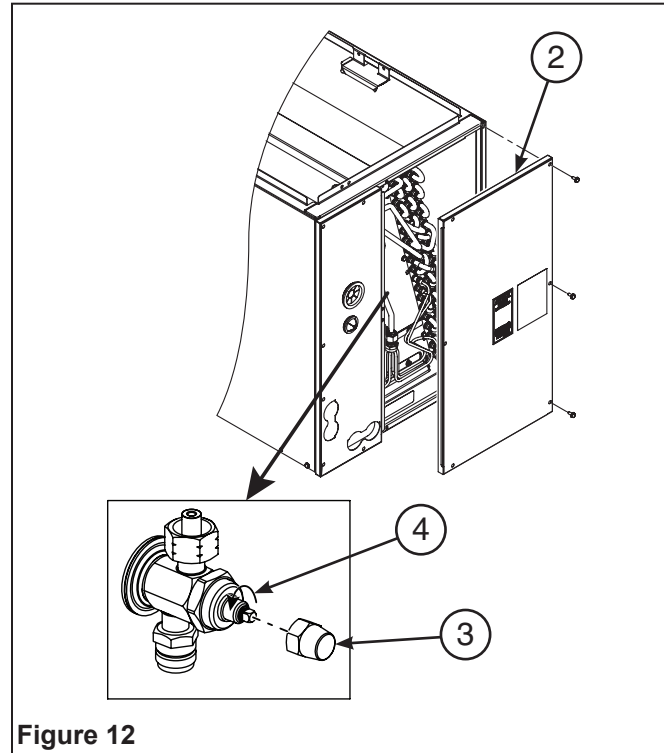

Figure 12

⚠ WARNING

Do not adjust TXV valve more than one full turn. Do not adjust below 10°F super heat to avoid reduction in system life.

About Trane and American Standard Heating and Air Conditioning

Trane and American Standard create comfortable, energy efficient indoor environments for residential applications. For more information, please visit www.trane.com or www.americanstandardair.com

The manufacturer has a policy of continuous data improvement and it reserves the right to change design and specifications without notice. We are committed to using environmentally conscious print practices.