

Envirowise[®]

INDOOR AIR SYSTEMS



Installation Instructions

INSTALLATION BY A HVAC PROFESSIONAL IS RECOMMENDED

The Envirowise SD12 is a split system dehumidifier with sensible cooling that is integrated into the heating and cooling system to provide the ultimate in comfort and property protection through:

- Dehumidification
- Sensible Cooling
- Fresh Air Ventilation (Optional)
- Air Filtration

The two-piece design allows the sensible heat load generated from dehumidifying the house to be released in the outside condensing unit, thus eliminating additional cooling requirements.

HVAC Installer: Please Leave Manual for Homeowner

P/N: EDHUMS12 Serial No.: _____ Install Date: _____

Installing Dealer: _____



TABLE OF CONTENTS

Safety Instructions	3
Specifications	4
General Set Up	5
Attaching Duct Collars	7
Electrical Requirements	8
Line Set Installation	11
Drain Installation	18
Ducting to HVAC Systems	19
Recommended HVAC System Installations	20
No Existing Ductwork Installation	21
Fresh Air Ventilation	22
Determine Ventilation Requirements	23
Controls	24
Filter Instructions	27
Optional Accessories	28
Service	29
Troubleshooting.....	29

Ingersoll Rand is committed to manufacturing quality products. To maintain our standards, product specifications may change without notice.



Ingersoll Rand, 6200 Troup Hwy. Tyler, TX 75707

Items Included in Box:

- Envirowise SD12 Dehumidifier
- Envirowise SD12 Condensing Unit
- Envirowise SD12 Installation Instructions
- Envirowise SD12 Leveling Feet

SAFETY INSTRUCTIONS

READ THE INSTALLATION, OPERATION AND MAINTENANCE INSTRUCTIONS CAREFULLY BEFORE INSTALLING AND OPERATING THIS DEVICE. PROPER ADHERENCE TO THESE INSTRUCTIONS IS ESSENTIAL TO OBTAIN MAXIMUM BENEFIT FROM YOUR ENVIROWISE WHOLE HOUSE VENTILATING DEHUMIDIFIER.

⚠ WARNING!

THIS SYMBOL MEANS IMPORTANT INSTRUCTIONS. FAILURE TO HEED THEM CAN RESULT IN SERIOUS INJURY OR DEATH.

⚠ CAUTION!

THIS SYMBOL MEANS IMPORTANT INSTRUCTIONS. FAILURE TO HEED THEM CAN RESULT IN INJURY OR MATERIAL PROPERTY DAMAGE.

Registrations



The Envirowise SD12 conforms to unified standard UL 474 and CSA Standard C22.2 No. 92.

⚠ WARNING!

120 VOLTS MAY CAUSE SERIOUS INJURY FROM ELECTRIC SHOCK. DISCONNECT ELECTRICAL POWER BEFORE STARTING INSTALLATION OR SERVICING, AND LEAVE POWER DISCONNECTED UNTIL INSTALLATION OR SERVICE IS COMPLETED.

IMPROPER INSTALLATION MAY CAUSE PROPERTY DAMAGE OR INJURY. INSTALLATION, SERVICE, AND MAINTENANCE MUST BE PERFORMED BY A QUALIFIED SERVICE TECHNICIAN.

⚠ CAUTION!

READ ALL INSTRUCTIONS BEFORE BEGINNING INSTALLATION.

ALWAYS USE CAUTION AND WEAR CUT RESISTANT GLOVES WHEN HANDLING SHEET METAL.

IMPROPER INSTALLATION MAY CAUSE PROPERTY DAMAGE OR INJURY. INSTALLATION, SERVICE, AND MAINTENANCE MUST BE PERFORMED BY A QUALIFIED SERVICE TECHNICIAN.

DEHUMIDIFIER IS HEAVY. HANDLE WITH CARE AND FOLLOW INSTALLATION INSTRUCTIONS.

DO NOT USE IN POOL APPLICATIONS, OR WARRANTY WILL BE VOID.

NEVER OPERATE A UNIT WITH A DAMAGED POWER CORD. IF THE POWER CORD IS DAMAGED, IT MUST BE REPLACED BY THE MANUFACTURER, ITS SERVICE AGENT, OR A SIMILARLY QUALIFIED PERSON IN ORDER TO AVOID A HAZARD.

THIS APPLIANCE IS NOT INTENDED FOR USE BY PERSONS (INCLUDING CHILDREN) WITH REDUCED PHYSICAL, SENSORY OR MENTAL CAPABILITIES, OR LACK OF EXPERIENCE OR KNOWLEDGE, UNLESS THEY HAVE BEEN GIVEN SUPERVISION OR INSTRUCTION CONCERNING THE USE OF THE APPLIANCE BY A PERSON RESPONSIBLE FOR THEIR SAFETY. CHILDREN SHOULD BE SUPERVISED TO ENSURE THAT THEY DO NOT PLAY WITH THE APPLIANCE.

THE CLEAN AIR ACT OF 1990 BANS THE INTENTIONAL VENTING OF REFRIGERANT (CFCs, HCFCs, AND HFCs) AS OF JULY 1, 1992. APPROVED METHODS OF RECOVERY, RECYCLING OR RECLAIMING MUST BE FOLLOWED. FINES AND/OR INCARCERATION MAY BE LEVIED FOR NONCOMPLIANCE.

SPECIFICATIONS

Dehumidifier

Part Number:	EDHUMS121S1MDA	
Blower:	406 CFM @ 0.0" WG 374 CFM @ 0.2" WG 348 CFM @ 0.4" WG	
Power:	160 Watts @ 80°F and 60% RH	
Supply Voltage:	115 VAC – 1phase – 60 Hz	
Current Draw:	1.4 Amps	
Transformer Protection:	Push Button Reset (located near power cord)	
Circuit Requirement:	15 Amps, Dedicated	
Energy Factor:	3.1 L/kWh	
Operating Range:	49°F Min, 95°F Max (Inlet Air Temperature)	
Sized For:	Up to 4,000 Square Feet	
Minimum Performance at:	80°F and 60% RH	70°F and 60% RH
Water Removal:	184 Pints/Day	150 Pints/Day
Sensible Cooling:	4,300 BTUs/Hour	5,100 BTUs/Hour
Efficiency:	6.6 Pints/kWh	6.0 Pints/kWh
Duct Connections:	6" Round Inlet; 10" Round Inlet; 10" Oval Outlet	
Air Filter:	MERV-11, Standard Pleat	
Efficiency:	65% ASHRAE® Dust Spot	
Size:	16" x 20" x 2"	
Power Cord:	9', 115 VAC, Ground	
Internal Insulated Cabinet:	Yes	
Drain Connection:	3/4" Threaded Female NPT	
Line Set Requirements:	50 Feet (maximum)	
Liquid Line:	1/4"	
Gas Line:	3/8"	

Dimensions:	Unit With Collars	Unit Without Collars	Shipping
Width:	20 1/4"	20 1/4"	35"
Height:	21 3/4"	21 3/4"	44"
Length:	41 1/2"	37 3/4"	44"
Weight:	110 lbs.	109 lbs.	225 lbs.

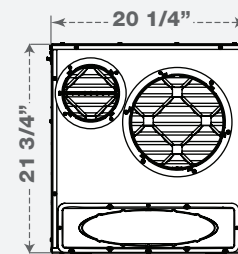

FRONT VIEW

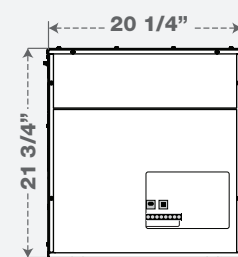

BACK VIEW

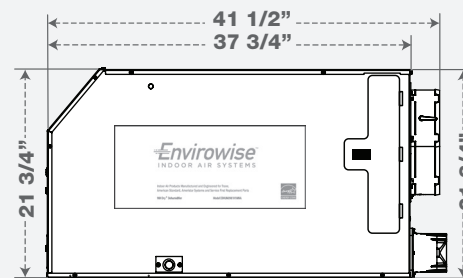

SIDE VIEW

Condenser

Part Number:	E4037626
Power:	1080 Watts @ 80°F and 60% RH
Supply Voltage:	115 VAC – 1phase – 60 Hz
Current Draw:	9.7 Amps
Minimum Circuit Ampacity:	20 Amps, Dedicated
Maximum Fuse / Breaker:	20 Amps
Refrigerant Type:	R410A
Refrigerant Amount:	36 oz.
Operating Range:	40°F Min, 115°F Max
Dimensions:	10"W x 25.5"H x 33"L - 75 lbs.
Power Cord:	Hard-Wired

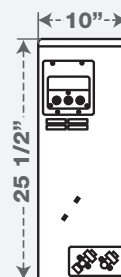

SIDE VIEW

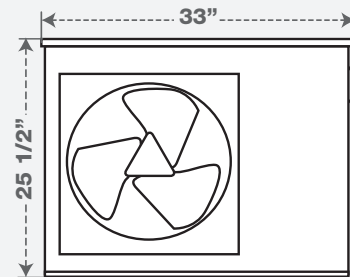

FRONT VIEW

Important Precautions

- The dehumidifier is designed to be installed indoors in a space that is protected from rain and flooding.
- Install the dehumidifier with enough space to access the back and side panels for maintenance and service.
- Avoid directing the discharge air at people.
- If used near a water source, be certain there is no chance the dehumidifier could fall into the water or get splashed and that it is plugged into a dedicated circuit and Ground Fault Circuit Interrupter (GFCI) protected outlet.
- DO NOT use the dehumidifier as a bench or table.
- DO NOT place the dehumidifier directly on structural building members without vibration absorbers or unwanted noise may result. Place the dehumidifier on supports to raise the base of the unit.
- A drain pan with a float switch MUST be placed under the dehumidifier if installed above a living area or above an area where water leakage could cause damage.

Location Considerations

- Avoid using the dehumidifier in stand-alone crawl space or basement applications. The cool air in the crawl space or basement, along with the cool air produced by the dehumidifier, will have a negative effect on the performance of the machine and cause the system to fall into a defrost cycle.
- Allow sufficient clearance to handle the unit's overall dimensions as well as the necessary return and supply ductwork to the unit.
- Allow sufficient clearance for filter removal and to prevent airflow obstruction.
- Electrical service access will require the removal of a side panel. Allow sufficient clearance on a side of the unit.
- Locate the dehumidifier in an area where the cord's length (9') easily reaches a 115 VAC electrical outlet with a minimum of a 15 Amp dedicated circuit capacity.
- Locate the dehumidifier in an area where field wiring the control (low voltage) to the unit will be possible.
- It is recommended that a backdraft damper be used in the discharge duct of the dehumidifier, especially when connecting to the supply ducting system. The backdraft damper prevents supply air from counter flowing through the dehumidifier when it is not operating. The dehumidifier's location should be chosen to allow installation of this accessory if necessary.
- The dehumidifier may be suspended from structural members with steel hanger straps or a suitable alternative, ensuring the assembly supports the dehumidifier's base in its entirety. DO NOT hang the dehumidifier from its cabinet.
- Allow for proper routing and drainage of needed drain pipes.

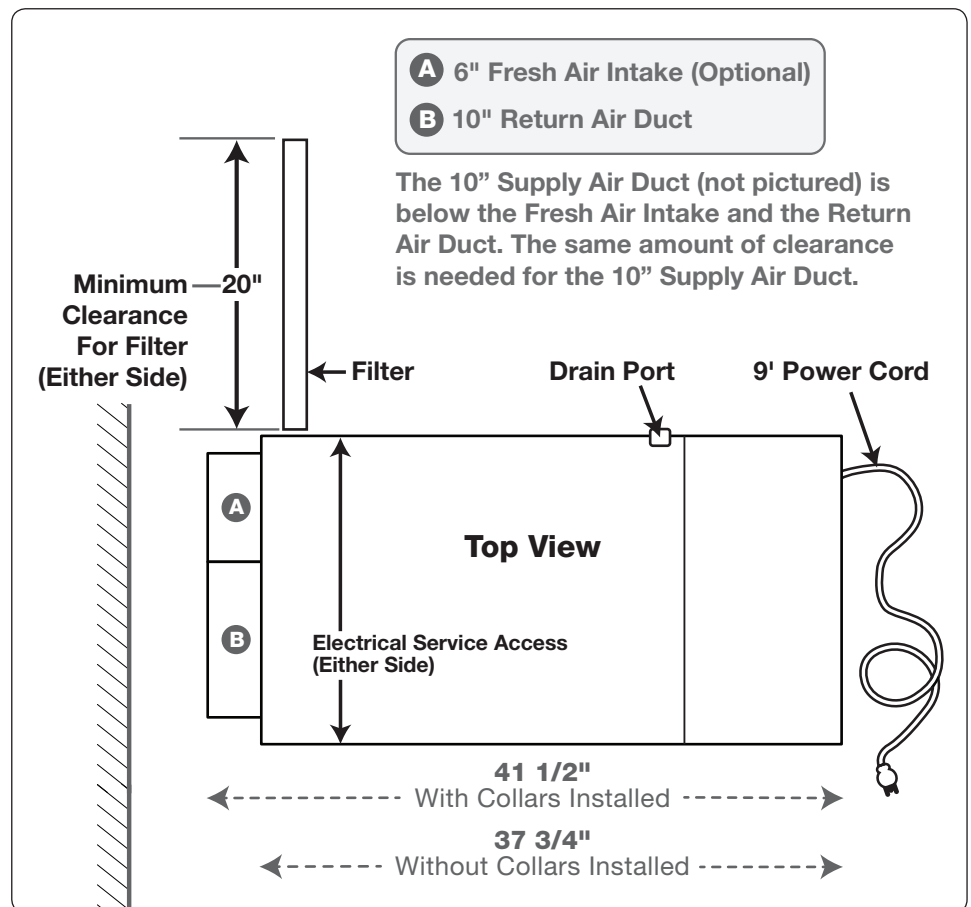

GENERAL SET UP

⚠ CAUTION!

THIS SYSTEM CONTAINS BOTH REFRIGERANT AND OIL. SOME RUBBER ROOFING MATERIAL MAY ABSORB OIL AND CAUSE THE RUBBER TO SWELL WHEN IT COMES INTO CONTACT WITH OIL. THE RUBBER WILL THEN BUBBLE AND COULD CAUSE LEAKS. PROTECT THE ROOF SURFACE TO AVOID EXPOSURE TO REFRIGERANT AND OIL DURING SERVICE AND INSTALLATION. FAILURE TO FOLLOW THIS NOTICE COULD RESULT IN DAMAGE TO ROOF SURFACE.

Important Precautions

- The condensing unit is designed to be installed outdoors in a space that is protected from extreme weather (rain, wind, etc.). Do not place the condensing unit in direct sunlight.
- Place the condensing unit at least 1" above ground level.
- Place the condensing unit as close as possible to the dehumidifier to minimize the length of the connecting lines. The maximum line set length is 50 feet.
- Ensure the mounting of the condensing unit can withstand strong winds and earthquakes when mounting above ground level.
- The condensing unit may be mounted to a wall (with brackets) or placed on a roof.
- Mount the base of the condensing unit to a sturdy level pad (or bracket) using 3/8" (10mm) bolts.
- Avoid directing the discharge air at people.
- If used near a water source, be certain there is no chance the condensing unit could fall into the water or get splashed and that it is plugged into a dedicated circuit and Ground Fault Circuit Interrupter (GFCI) protected outlet.
- DO NOT use the condensing unit as a bench or table.
- DO NOT place the condensing unit where the sound and vibration caused by running the unit will cause a nuisance. Vibration dampening material may be installed between the condensing unit base and the mounting pad if required.

Location Considerations

- Allow sufficient clearance to handle the unit's overall dimensions.
- Place the condensing unit where there is adequate space for the unit and the air required by the unit.
- Install the condensing unit with space to access the top and side panels for maintenance and service.

Minimum Distance Required for Condensing Unit and The Footing Dimensions

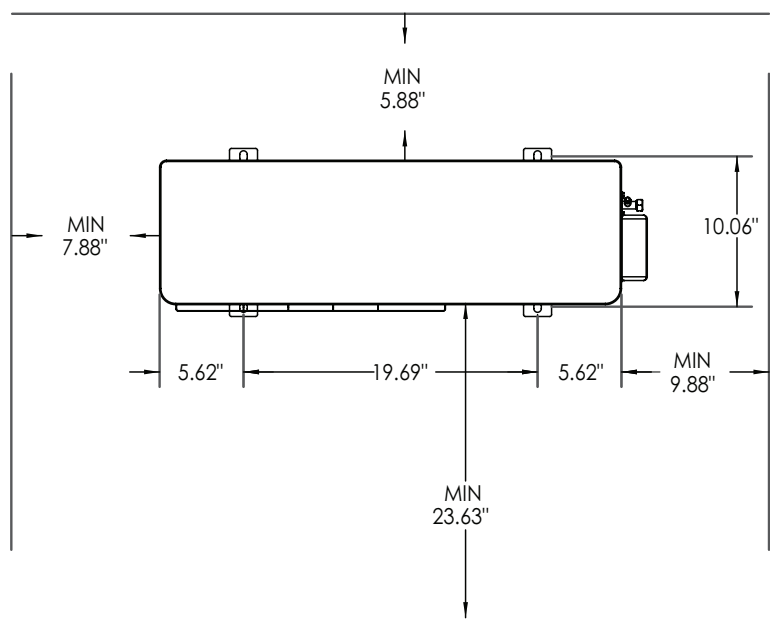

ATTACHING DUCT COLLARS

Duct Collar Installation

Remove the two round ducts, oval duct, and oval duct seal and small bag of mounting hardware from inside the rectangle opening.

Fresh Air Ventilation Duct

Fresh air ventilation is optional. Attach 6" diameter duct to the unit using the screws provided. The 6" duct should be capped if fresh air is not desired. If setting up the unit to provide fresh air ventilation, see page 24.

Return Air Inlet

Attach 10" diameter duct collar to the unit with the screws provided.

Supply Air Outlet

Adhere seal onto the back of the oval duct and mount the duct to the front of the dehumidifier using the screws provided.

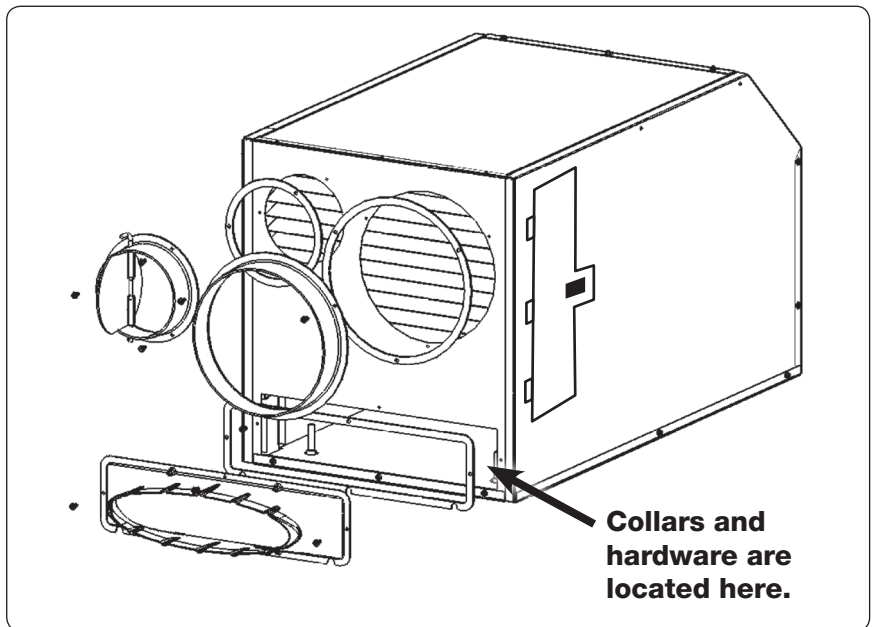
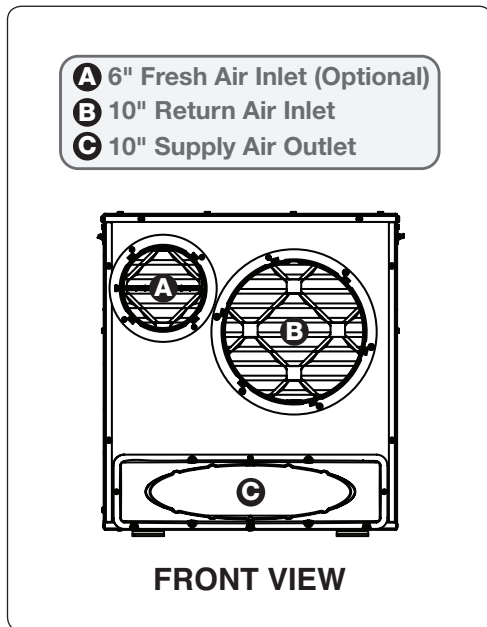

GENERAL SET UP

Electrical Requirements

⚠ WARNING!

ELECTRIC SHOCK HAZARD. CAN CAUSE INJURY OR DEATH. UNIT MUST BE GROUNDED IN ACCORDANCE WITH NATIONAL AND LOCAL CODES. DISCONNECT ALL REMOTE ELECTRIC POWER SUPPLIES BEFORE OPENING ACCESS PANEL. UNIT MAY HAVE MULTIPLE POWER SUPPLIES.

The dehumidifier plugs into a dedicated grounded 115 VAC outlet. The device draws 1.4 Amps at 80°F and 60% RH and can be plugged into a shared branch circuit. Locate the dehumidifier in an area where the cord's length (9') easily reaches a 115 VAC electrical outlet. If used in an area that may become wet, a GFCI protected circuit is recommended. Consult local electrical codes for further information. Field wiring must comply with the National Electric Code (C.E.C. in Canada) and any applicable local codes or ordinances.

Envirowise offers a variety of control devices for use with the Envirowise SD12. The control is to be located remotely from the dehumidifier and placed in the space to be conditioned. A low voltage (24 Volt) control **MUST** be used with the Envirowise SD12 and **MUST** be connected with low voltage (18-22 gauge) thermostat wire.

⚠ WARNING!

THE REMOTE CONTROLS OF THE ENVIROWISE SD12 ARE POWERED BY A LOW VOLTAGE CIRCUIT (24 VAC) AND MUST NEVER CONTACT OR BE CONNECTED TO A HIGH VOLTAGE CIRCUIT.

⚠ CAUTION!

DO NOT ALLOW THE 24V TERMINAL TO CONTACT THE COM TERMINAL ON THE ENVIROWISE SD12 OR DAMAGE TO THE TRANSFORMER WILL RESULT.

⚠ CAUTION!

SOME OF THE SCREW TERMINALS ON THE ENVIROWISE SD12 MAY NOT BE USED WITH CERTAIN CONTROLS AND SHOULD BE LEFT UNCONNECTED.

Electrical Precautions

- Do not install the control where it may not accurately sense the relative humidity such as near HVAC supply registers, near exterior doors, on an outside wall, near a window, or near a water source.
- The screw terminals on the Envirowise SD12 and the control are labeled to prevent confusion.
- Be sure to consult the electrical schematic in the CONTROLS Section (page 24) of this manual or inside the access panel of the dehumidifier before making control connections.

Dehumidifier Wiring Diagram

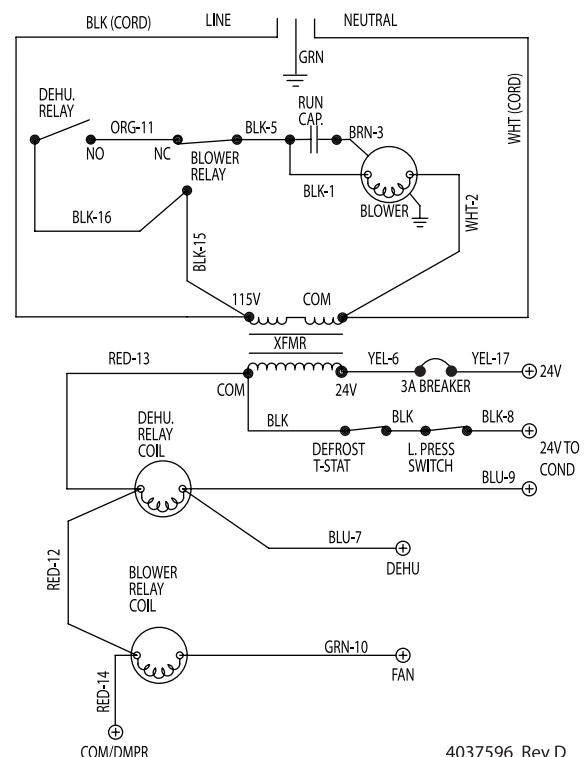

Electrical Requirements

The condensing unit requires a dedicated 120 VAC 20 Amp circuit capacity. Install a properly sized branch circuit disconnect (20 Amp) within sight of the unit. The installer must supply the power wiring for the condensing unit. The power wiring must have a Minimum Circuit Ampacity of 20A and be run within a rain-tight conduit. The condensing unit must be grounded as required by applicable code(s).

Field Wiring the Condensing Unit:

1. Take off the panel (top), by removing the one screw that secures it to the condensing unit.
2. Loosen the two strain relief block screws.
3. Insert the power and control wires through the strain relief block.
4. Connect the power supply wires and control wires to the corresponding terminals on the terminal board.
5. Ground the condensing unit in accordance with local and national electrical codes.
6. Secure the power and control wires to the strain relief block by tightening the screws.
7. Reinstall the panel (top) by inserting the one screw that secures it to the condensing unit.

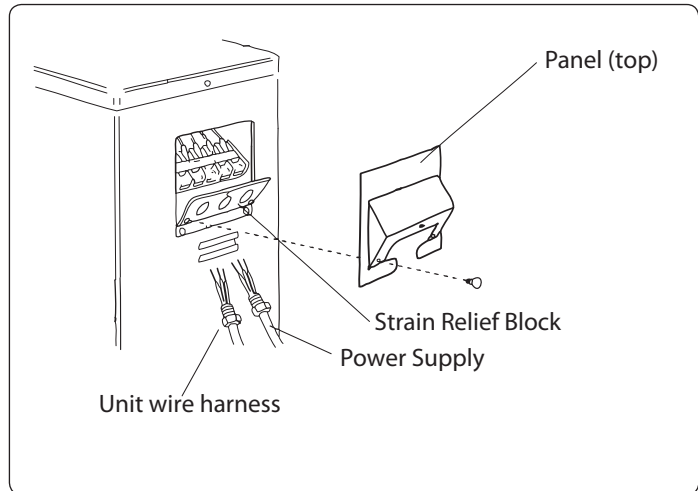

Condensing Unit Electrical Control Connections:

Connect the “24V TO COND” terminals on the dehumidifier to terminal 1 and N for “24VAC SIGNAL FROM DEHU” on the condensing unit.”

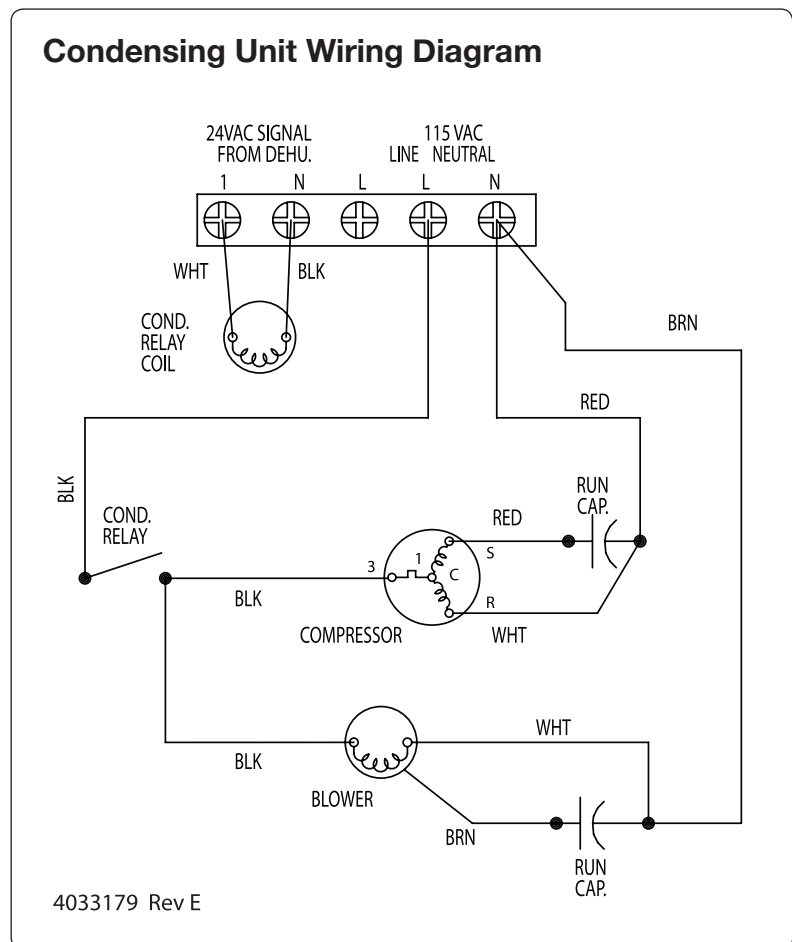

GENERAL SET UP

Electrical Requirements

Condensing Unit and Dehumidifier Wiring

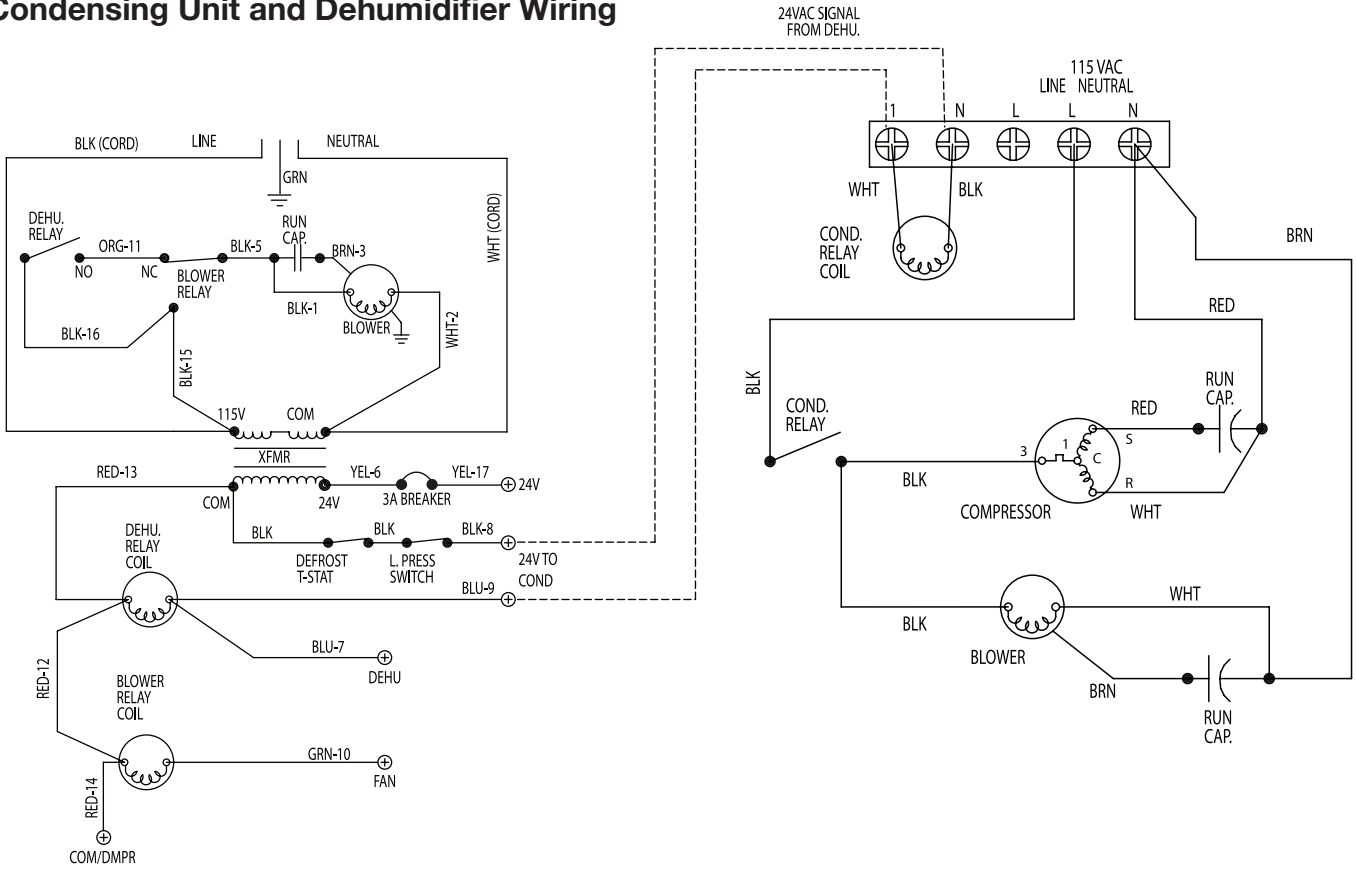

Line Set Installation

The installer must supply a line set (1/4" liquid line, 3/8" gas line) suitable for use with R410A refrigerant to connect the indoor unit to the outdoor unit. **The maximum allowable length of the line set is 50 feet.** The installer must braze the lines to the dehumidifier and the condensing unit. The gas (suction) line must be insulated to prevent the formation of condensation on the outside of the line. Contact technical support for questions on longer line set lengths.

Refrigerant Line Set - Transition From Vertical to Horizontal

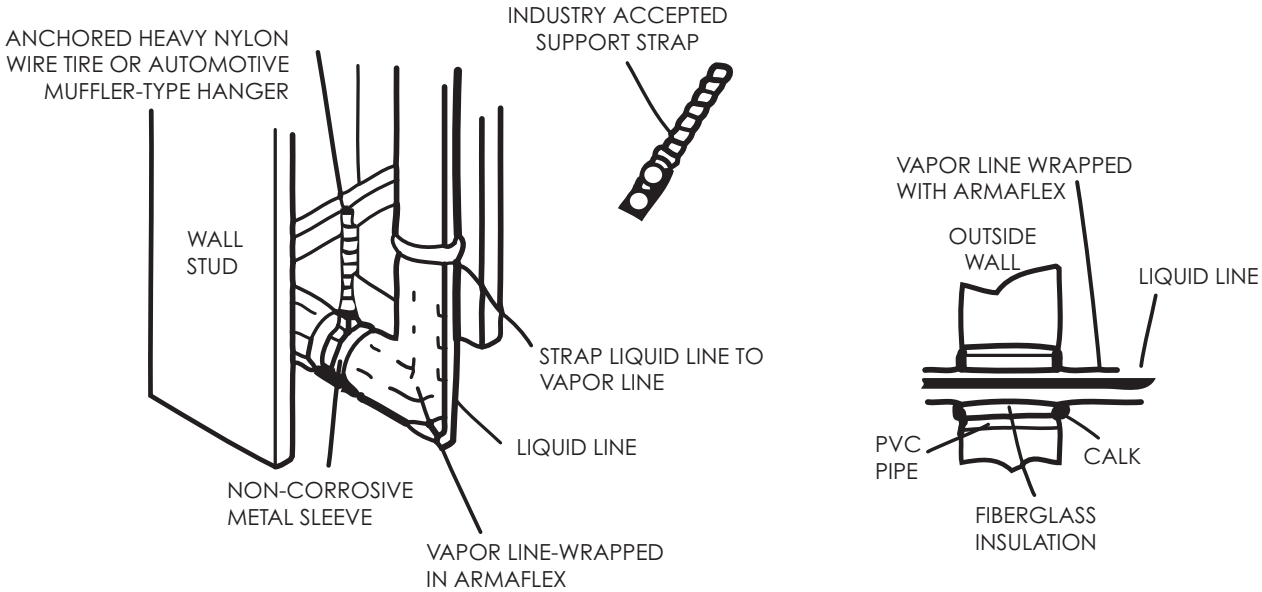

Refrigerant Line Set - Installing Horizontal Runs

To hang line set from joist or rafter, use either metal strapping material or anchored heavy nylon wire ties.

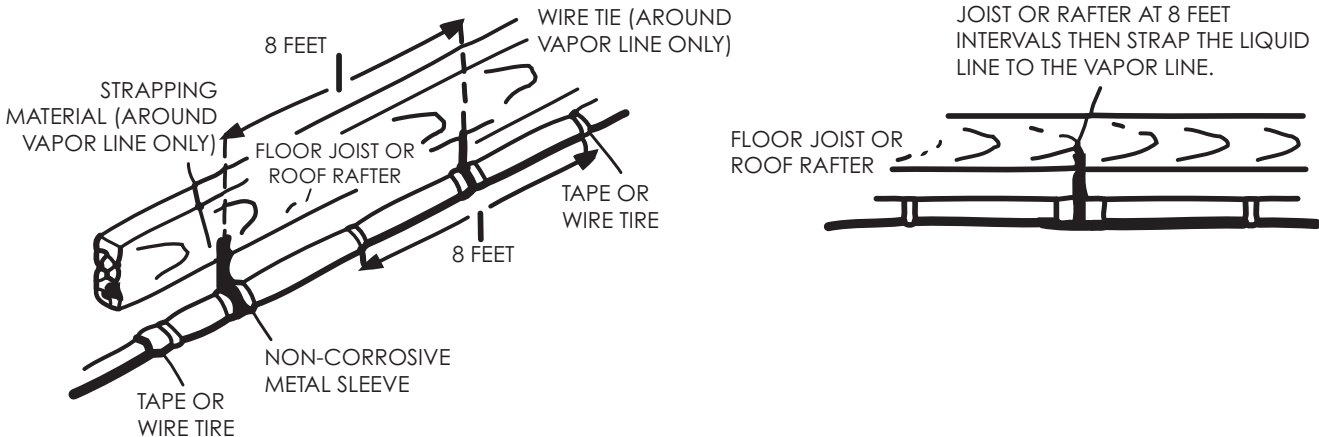

GENERAL SET UP

Line Set Installation

When installing the line set:

- Make sure the lines are suitable for use with R410a.
- Do not crush the lines and always allow a minimum bend radius of 2 inches.
- Keep the ends of the lines covered to prevent dirt and debris from entering the lines during installation.
- Secure the line set to the building with isolating hardware to prevent vibration transmission to the building.
- Seal and isolate the opening(s) where the line set is routed into the building.
- Insulate the gas (suction) line to prevent water condensation on the gas line.
- Flush the lines with an inert gas before and/or during brazing to prevent oxidation inside the lines.
- Release the inert gas holding charge and remove the plugs in the dehumidifier lines before brazing.
- Do not overheat the lines connected to the dehumidifier or the condensing unit when brazing.
- Be aware of the relative location of the dehumidifier (Indoor unit) and condensing unit (Outdoor Unit) when installing the line set.

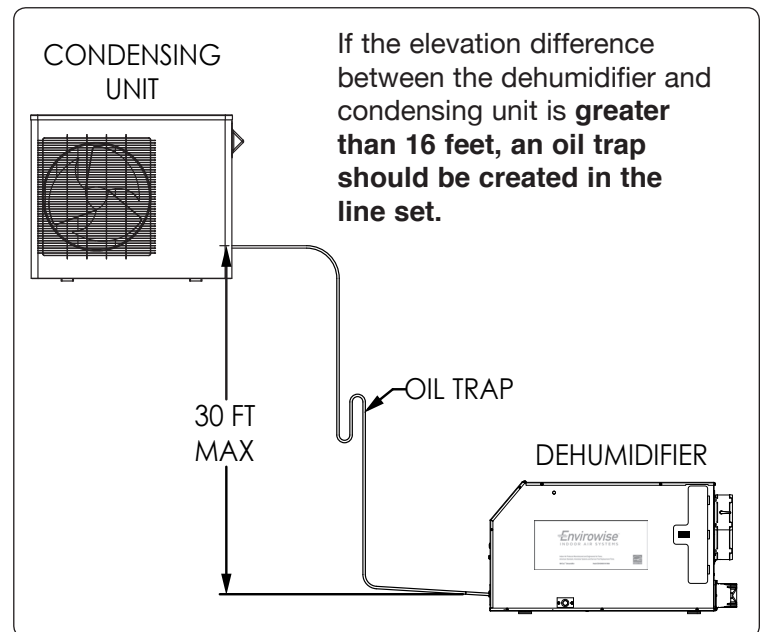
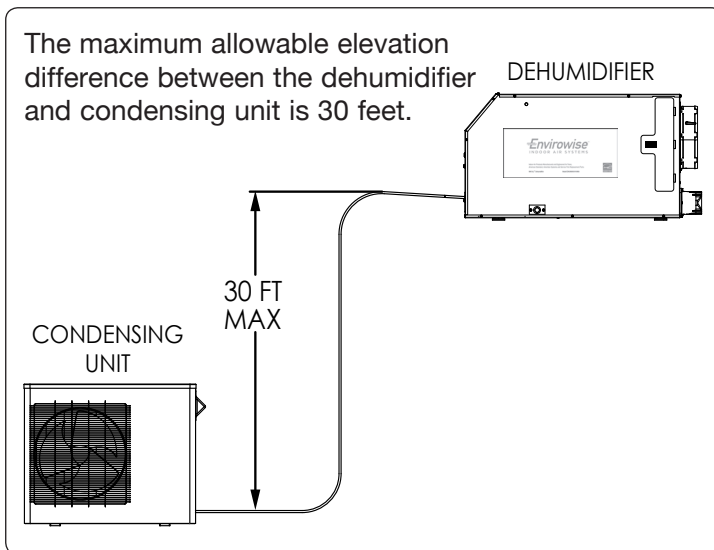

Line Set Installation

Brazing the Line Set

⚠ WARNING!

POLYOL ESTER (POE) OILS USED WITH HFC-410A REFRIGERANT ABSORB MOISTURE VERY QUICKLY. IT IS VERY IMPORTANT THAT THE REFRIGERANT SYSTEM BE KEPT CLOSED AS MUCH AS POSSIBLE. DO NOT REMOVE LINE SET CAPS OR SERVICE VALVE STUB CAPS UNTIL YOU ARE READY TO MAKE CONNECTIONS.

⚠ WARNING!

WHEN USING A HIGH PRESSURE GAS SUCH AS DRY NITROGEN TO PRESSURIZE A REFRIGERATION OR AIR CONDITIONING SYSTEM, USE A REGULATOR THAT CAN CONTROL THE PRESSURE DOWN TO 1 OR 2 PSIG.

⚠ CAUTION!

BRAZING ALLOYS AND FLUX CONTAIN MATERIALS WHICH ARE HAZARDOUS TO YOUR HEALTH. AVOID BREATHING VAPORS OR FUMES FROM BRAZING OPERATIONS. PERFORM OPERATIONS ONLY IN WELL-VENTILATED AREAS. WEAR GLOVES AND PROTECTIVE GOGGLES OR FACE SHIELD TO PROTECT AGAINST BURNS. WASH HANDS WITH SOAP AND WATER AFTER HANDLING BRAZING ALLOYS AND FLUX.

TO PREVENT STRIPPING OF THE VARIOUS CAPS USED, THE APPROPRIATELY SIZED WRENCH SHOULD BE USED AND FITTED SNUGLY OVER THE CAP BEFORE TIGHTENING.

ALLOW BRAZE JOINT TO COOL BEFORE REMOVING THE WET RAG FROM THE SERVICE VALVE. TEMPERATURES ABOVE 250° CAN DAMAGE VALVE SEALS.

USE SILVER ALLOY BRAZING RODS WITH 5% MINIMUM SILVER ALLOY FOR COPPER-TO-COPPER BRAZING. USE 45% MINIMUM SILVER ALLOY FOR COPPER-TO-BRASS AND COPPER-TO-STEEL BRAZING.

⚠ WARNING!

FIRE, EXPLOSION AND PERSONAL SAFETY HAZARD. FAILURE TO FOLLOW THIS WARNING COULD RESULT IN DAMAGE, PERSONAL INJURY OR DEATH. NEVER USE OXYGEN TO PRESSURIZE OR PURGE REFRIGERATION LINES. OXYGEN WHEN EXPOSED TO A SPARK OR OPEN FLAME, CAN CAUSE FIRE AND/OR AN EXPLOSION, THAT COULD RESULT IN PROPERTY DAMAGE, PERSONAL INJURY OR DEATH.

Note: There is a service port inside the dehumidifier (on the gas line) and both stub tubes of condensing unit. These service ports can be used to introduce and release nitrogen during brazing.

GENERAL SET UP

Line Set Installation

⚠ CAUTION!

THE DEHUMIDIFIER IS SHIPPED FROM THE FACTORY PRESSURIZED WITH A CHARGE OF INERT GAS AND WITH RUBBER PLUGS IN THE LINES. PURGE THE INERT GAS FROM THE DEHUMIDIFIER BY REMOVING THE RUBBER PLUGS IN THE LIQUID AND GAS LINES TO RELEASE THE INERT GAS BEFORE CONNECTING THE LINE SET.

Note: If there is no pressure in the dehumidifier when the first plug is removed, check the dehumidifier for damage and leaks before continuing with the installation.

Use the following procedure to connect the line set to the Dehumidifier:

1. Purge the inert gas from the dehumidifier by removing the rubber plugs in the liquid and gas lines to release the inert gas before connecting the line set.
2. Place a field-provided heat shield, such as a wet rag, against the dehumidifier and around the piping stubs. The heat shield must be in place to protect the cabinet from heat damage.
3. Swage the liquid and gas lines (if necessary) to fit onto the dehumidifier lines.
4. Purge the dehumidifier lines and the line set with dry nitrogen (Inert gas) to prevent oxidation during brazing. Flow dry nitrogen into the lines at a low pressure of 1 to 2 psig.
5. Braze the line set lines to the dehumidifier lines.
6. Remove the heat shield after brazing and allow the connections to cool.

Use the following procedure to connect the line set to the Condensing Unit:

1. Cut the line set lines to the proper required length. Deburr the cut ends of the line set lines.
2. Fit the line stubs with flare fittings (included with the condensing unit) onto the line set if necessary.
3. Swage the liquid and gas lines (if necessary) to fit onto the line stubs with the flare fittings.
4. Remove service valve caps and cores.
5. Purge the lines with dry nitrogen (Inert gas) to prevent oxidation during brazing.
6. Braze the line set lines to the line stubs.
7. Apply a light coating of refrigeration oil to the flare fitting threads on the condensing unit valves.
8. Start each flare nut on the corresponding flare fitting on the condensing unit valves by hand, making sure the threads are properly engaged. Tighten the flare nuts hand tight.
9. Carefully torque the flare nuts to the corresponding flare fittings on the condensing unit valves.
 - Torque the liquid line flare nut to 13.3 ft-lbs.
 - Torque the suction line flare nut to 30.1 ft-lbs.
10. Reinstall service valve caps and cores.

Note: Alternately, the stubs with the flare fittings can be connected to the condensing unit before brazing the line set. In this case a field provided heat shield, such as a wet rag, must be placed over the flare fittings and valves on the condensing unit to protect them from heat damage. The service valve cap and core should be removed before brazing near stub tubes.

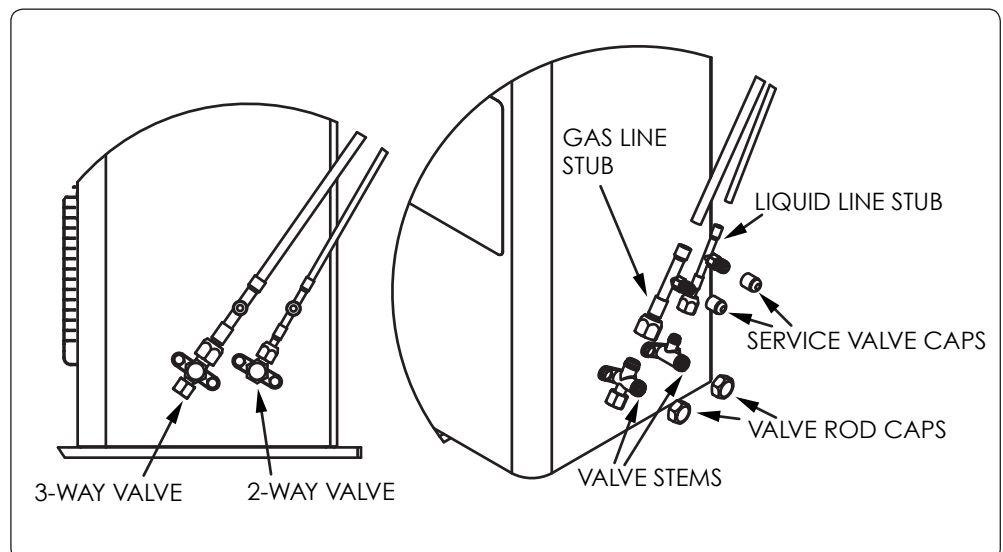

Line Set Installation

Leak Test Line Set and Dehumidifier

Manifold Gauge Set

When checking the system charge, use a manifold gauge set that features low loss anti-blow back fittings.

Manifold gauge set used with HFC-410A refrigerant systems must be capable of handling the higher system operating pressures. The gauges should be rated for use with high side operating pressures of 0 – 800 psig and low side operating pressures of 30 inches of vacuum to 250 psig. Dampened gauges or anti-flutter gauges are recommended. Gauge hoses must be rated for use at up to 800 psig of pressure with a 4000 psig burst rating.

⚠ CAUTION!

THE ENVIRONMENTAL PROTECTION AGENCY (EPA) PROHIBITS THE INTENTIONAL VENTING OF HFC REFRIGERANTS DURING MAINTENANCE, SERVICE, REPAIR AND DISPOSAL OF APPLIANCE. APPROVED METHODS OF RECOVERY, RECYCLING OR RECLAIMING MUST BE FOLLOWED.

⚠ WARNING!

WHEN USING A HIGH PRESSURE GAS SUCH AS DRY NITROGEN TO PRESSURIZE A REFRIGERATION OR AIR CONDITIONING SYSTEM, USE A REGULATOR THAT CAN CONTROL THE PRESSURE DOWN TO 1 OR 2 PSIG.

⚠ CAUTION!

LEAK DETECTOR MUST BE CAPABLE OF SENSING HFC REFRIGERANT.

⚠ WARNING!

REFRIGERANT CAN BE HARMFUL IF IT IS INHALED. REFRIGERANT MUST BE USED AND RECOVERED RESPONSIBLY. FAILURE TO FOLLOW THIS WARNING MAY RESULT IN PERSONAL INJURY OR DEATH.

1. Connect the HFC-410A manifold gauge set high pressure hose to the service port on the suction gas line. **Note:** Connecting the high pressure hose to the service port on the gas line will protect the manifold gauge set from high pressure damage during leak testing. Cap liquid line service port.
2. Make sure all of the valves on the manifold gauge set are closed. Connect a cylinder of HFC-410A refrigerant to the center port of the manifold gauge set.
3. Position the HFC410A refrigerant cylinder to deliver vapor only. Open the valve on the HFC-410A refrigerant cylinder.
4. Open the high pressure side of the manifold gauge set to allow HFC-410A into the line set and dehumidifier. Weigh in a trace amount of HFC-410A [A trace amount is a maximum of two ounces (57g) of refrigerant or 3 PSI]. Close the valve on the HFC-410A cylinder and the valve on the high pressure side of the manifold gauge set.
5. Disconnect the HFC-410A refrigerant cylinder from the manifold gauge set.
6. Connect a cylinder of dry nitrogen with a pressure regulating valve to the center port of the manifold gauge set.
7. Adjust the dry nitrogen pressure regulator to 150 psig. Open the valve on the high pressure side of the manifold gauge set to pressurize the line set and dehumidifier.
8. Close the valve on the dry nitrogen cylinder. Close the valve on the high pressure side of the manifold gauge set.
9. Allow the system to rest for a few minutes.
10. Check all (brazed and threaded) joints for leaks using a leak detector designed to sense HFC refrigerants.
11. After leak testing is complete, disconnect the dry nitrogen cylinder from the center port of the manifold gauge set and disconnect the high pressure hose of the manifold gauge set from the suction gas line service port.

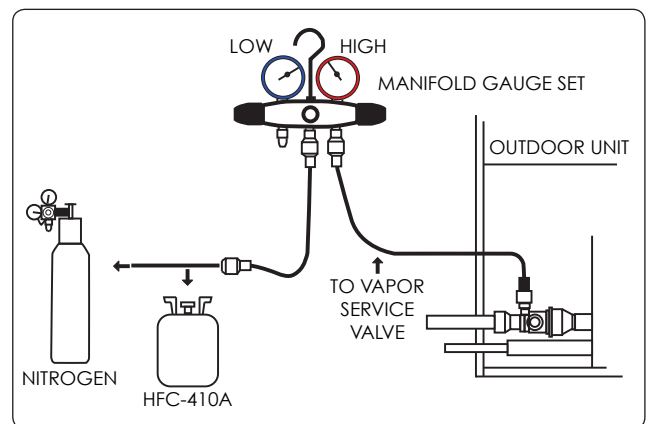

GENERAL SET UP

Line Set Installation

Evacuating the Line Set and The Dehumidifier

1. Remove the valve cores from the service ports on the liquid and gas line stubs using no-loss valve core removal tools.
2. Connect a 1/4" SAE in-line tee to the gas line stub valve core removal tool.
3. Connect the low pressure side of the manifold gauge set to one of the ports on the 1/4" SAE in-line tee.
4. Connect a micron gauge to the remaining port of the 1/4" SAE in-line tee.
5. Connect the high pressure side of the manifold gauge set to the liquid line stub service port.
6. Connect a vacuum pump to the center port on the manifold gauge set.
7. Open the valve core removal tool valves.
8. Open the high and low pressure sides of the manifold gauge set and start the vacuum pump.
9. After evacuating for a few minutes, close the high and low pressure sides of the manifold gauge set and observe the behavior of the micron gauge. A rapid rise in the micron gauge reading (pressure) indicates a leak in the system. If this occurs, check the manifold gauge set, hoses, tee, and valve core removal tools for leaks. If no leak is found, repeat the leak test procedure on Page 15.
10. Evacuate the line set and dehumidifier for a minimum of 15 minutes and check that the micron gauge reads below 500 microns.
11. Close the low and high pressure sides of the manifold gauge set and stop the vacuum pump.
12. Wait 10 minutes.
13. If the micron gauge reading rises above 800 microns, check for leaks and return to step 9.
14. If the micron gauge reading remains below 800, close the valves on the valve core removal tools.
15. Remove the tee from the gas line stub valve core removal tool. Connect the low pressure side of the manifold gauge set to the gas line stub valve core removal tool.
16. Install the valve core into the liquid line stub service port.
17. Remove the vacuum pump from the center port of the manifold gauge set and proceed to the next section to charge the system.

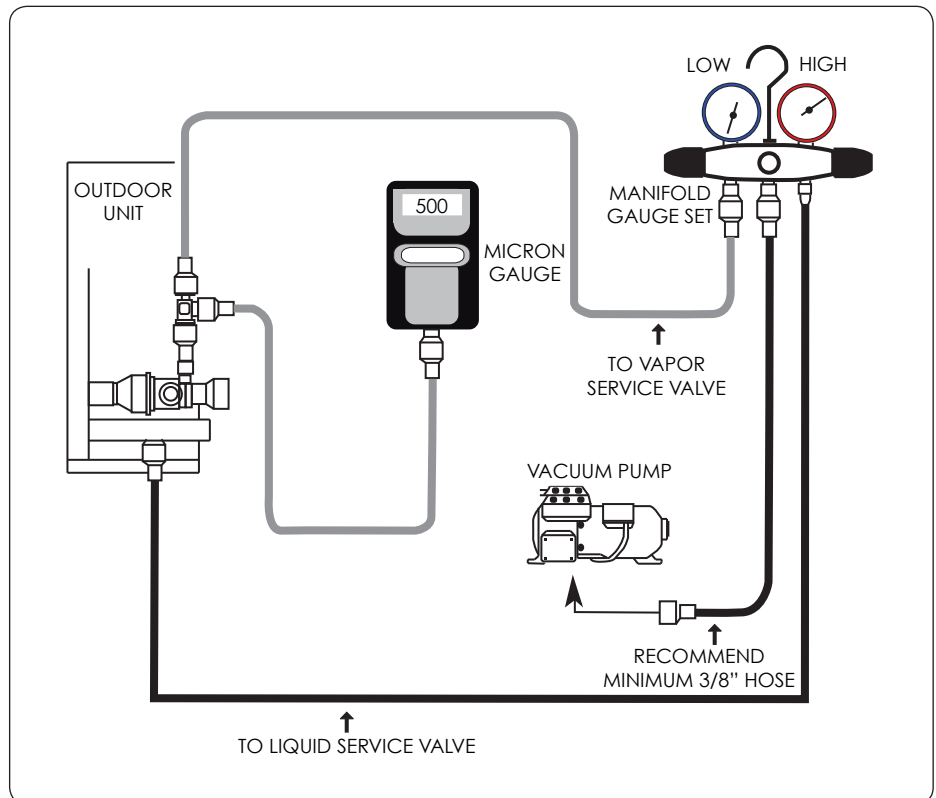

Line Set Installation

Charging the System

The condensing unit is pre-charged with 36 oz. of HFC-410A refrigerant. The installer will add HFC-410A refrigerant for the dehumidifier and line set.

1. Calculate the amount of HFC-410A required by determining the length of the line set and performing the calculation below:
 $11\text{oz} + 2.2\text{oz per every 10 feet of line set length} = \text{Total charge required}$
2. Connect a cylinder of HFC-410A refrigerant to the center port of the manifold gauge set. Position the HFC-410A refrigerant cylinder to deliver liquid only.
3. Open the valve on the HFC-410A cylinder.
4. Place the HFC-410A cylinder on a refrigerant scale and zero the scale.
5. Open the valve on the gas line stub valve core removal tool.
6. Open the low pressure side of the manifold gauge set and weigh in the amount of HFC-410A calculated in step 1.
7. Close the valve on the HFC-410A cylinder and the low pressure side of the manifold gauge set.
8. Close the valve on the gas line stub valve core removal tool.
9. Remove the high and low pressure sides of the manifold gauge set from the valve core removal tools.
10. Install the valve core in the gas line stub port using the no-loss valve core removal tool
11. Remove the no-loss valve core removal tools from the service ports on the liquid and gas line stubs.
12. Install the caps on the service ports of the liquid and gas line stubs finger tight, then tighten an additional 1/6 turn. Check the service port caps for leakage – reinstall if necessary.

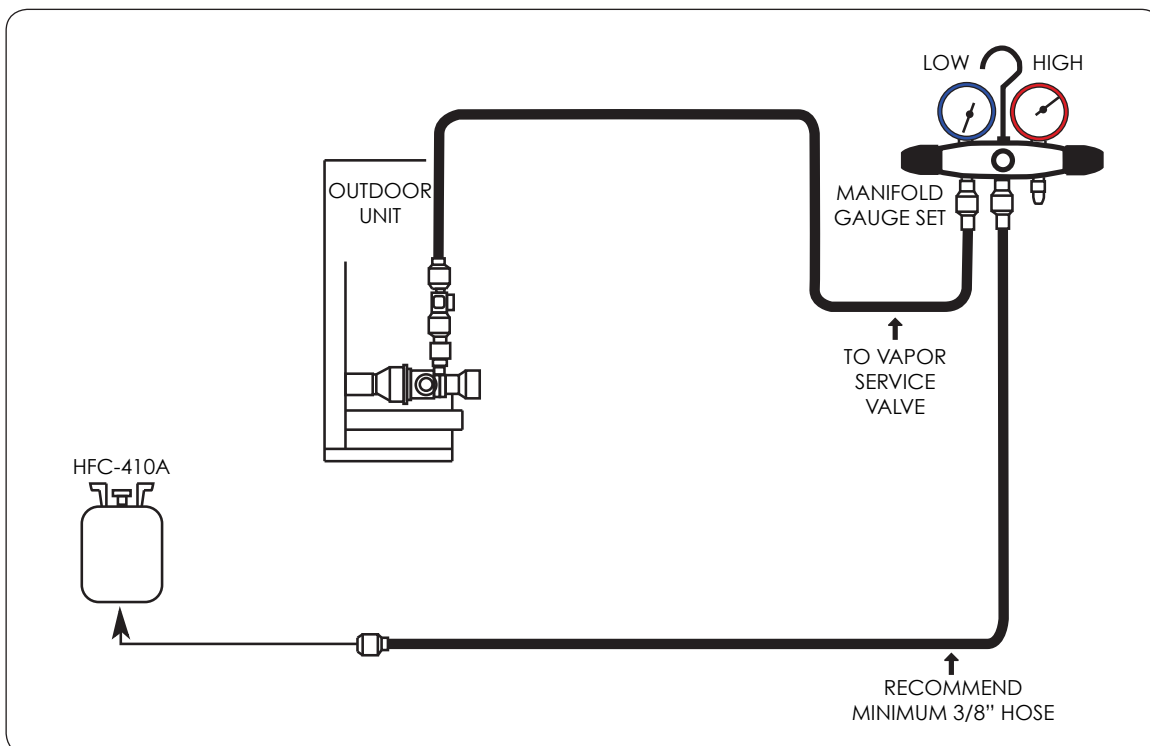
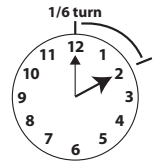

GENERAL SET UP

Drain Installation

The Envirowise SD12 dehumidifier generates condensate.

Place a secondary drain pan with a float switch under the dehumidifier if it is suspended above a finished area or above an area where water leakage could cause damage.

A drain trap is required for the dehumidifier to drain properly. Install a 3/4" threaded male NPT adapter to the drain pan. Install a drain pipe assembly utilizing 3/4" PVC pipe to transport the condensate to a drain. Pitch of drain should be 1" per 10'.

An optional condensate pump kit is available for use with the Envirowise SD12 and may be installed if lift is required to dispose of condensate. Condensate is automatically pumped to a remote location when the water level in the pump's reservoir rises to close the float switch.

The pump also contains a safety float switch. The white leads from this switch extend from beneath the pump cover. This switch should be installed in series with the field wire that connects to the common lead from the Envirowise SD12 to the control panel. If the pump fails, this switch opens the common control circuit and stops water production before the reservoir overflows. Contact a qualified electrician to install the safety float switch to the Envirowise SD12 dehumidifier.

Note: An optional condensate pump kit and an automatic cut-off device can be purchased through your dealer or online.

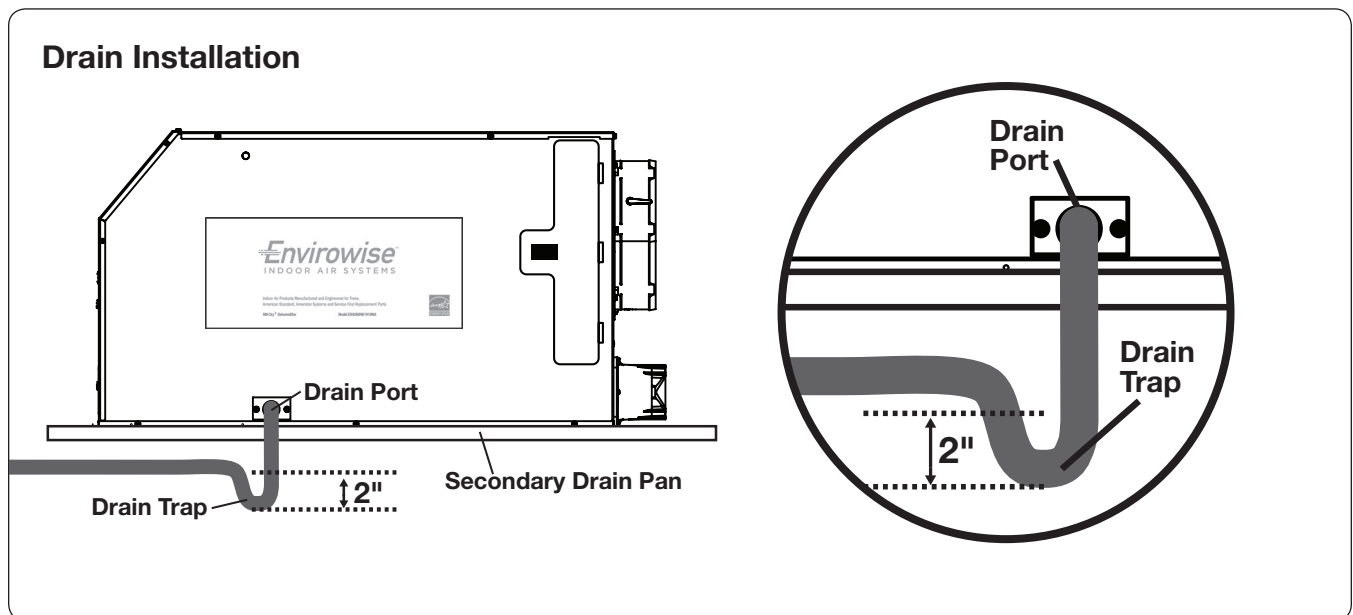

Ducting to HVAC Systems

The recommended installation creates a separate return for the Envirowise SD12 in a central area of the structure. Duct the supply of the unit to the air supply of the existing HVAC system. Connect an insulated duct from outside to the 6" collar of the Envirowise SD12 to provide fresh make-up air. Adjust the damper in the duct to provide the desired amount of fresh air.

CAUTION!

**DO NOT CONNECT WITH A STATIC PRESSURE GREATER THAN OR EQUAL TO +0.5 WG.
CONTACT TECHNICAL SUPPORT AT (800) 533-7533 FOR ADDITIONAL DETAILS.**

Ducting Considerations:

- All flexible ducting connected to the Envirowise SD12 should be UL listed.
- A short piece of flexible ducting on all Envirowise SD12 duct connections is recommended to reduce noise and vibration transmitted to rigid ductwork in the structure.
- Use a minimum 10" diameter round or equivalent rectangular duct for total duct lengths of up to 25'. Use a minimum 12" diameter round or equivalent rectangular duct for longer lengths.
- Grills or diffusers on the duct ends must not excessively restrict airflow.
- A length of 10" or more of insulated flex duct or any other vibration isolating material on the outlet of the Envirowise SD12 will reduce air noise from the blower.
- Effective dehumidification may require that ducting be branched to isolated, stagnant air flow areas. When ducting to two or three areas, use 8" or larger diameter branch ducting. When ducting to four or more areas, use 6" or larger diameter branch ducting. Provisions must be made to provide airflow from supply locations to the central return location. Proper air distribution is important to ensure even humidity control and heat distribution throughout the structure.
- DO NOT locate the return in a bathroom or a kitchen.

System Start Up:

1. Rotate the condensing unit fan to check for binding.
2. Inspect all factory and field wiring for loose connections.
3. Check the voltage supply at the condensing unit disconnect switch and make sure it is 120 VAC $\pm 10\%$. If the supply voltage is outside this range, do not start the system and repair the power supply circuit.
4. Plug in the dehumidifier and set the remote control to dehumidify. Close the condensing unit disconnect to start the condensing unit.
5. Recheck the voltage supply at the condensing unit and make sure it is 120 VAC $\pm 10\%$ while the unit is operating.
6. Check the condensing unit and dehumidifier operation.

GENERAL SET UP

Recommended HVAC Ducting Installations

The recommended installation draws air from a dedicated indoor air return and ducts the supply of the dehumidifier to the air return of the existing HVAC system. Utilize the optional fresh air ventilation duct to provide outside air.

- Install a dedicated 10" air return for the Envirowise SD12 from a central area of the structure.
- Install an insulated duct from outside to the 6" collar of the Envirowise SD12 to provide fresh air ventilation (optional).
- Duct the supply of the Envirowise SD12 to the return side of the existing HVAC system with a backdraft damper. HVAC system interlock is recommended.
- DO NOT locate return in a bathroom or kitchen.
- The optional D30 or a system thermostat control with integrated dehumidification software should be located remotely from the dehumidifier and placed in a central location.

Attic Installation - Dedicated Return to HVAC Return

Create a separate return for the Envirowise SD12 in a central area of the building.

Installing the supply air from the Envirowise SD12 to the return of the HVAC system requires the HVAC fan to run when the Envirowise SD12 is operating.

HVAC system fan interlock is recommended to reduce potential comfort issues with this application.

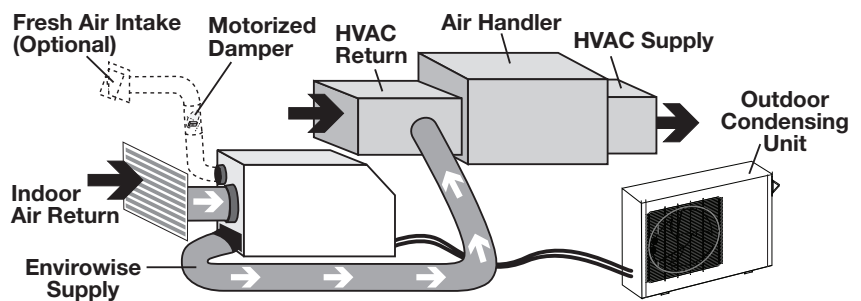

Basement/Crawl Space Installation - Dedicated Return to HVAC Return

Duct the supply of the Envirowise SD12 to a 10" x 10" x 10" tee damper that is 20 percent open to the basement/crawl space.

Positive pressurization of crawl spaces with dehumidification added could potentially bring unwanted, unhealthy air into living spaces. The recommended application with dehumidification added is to achieve neutral pressure in crawl spaces.

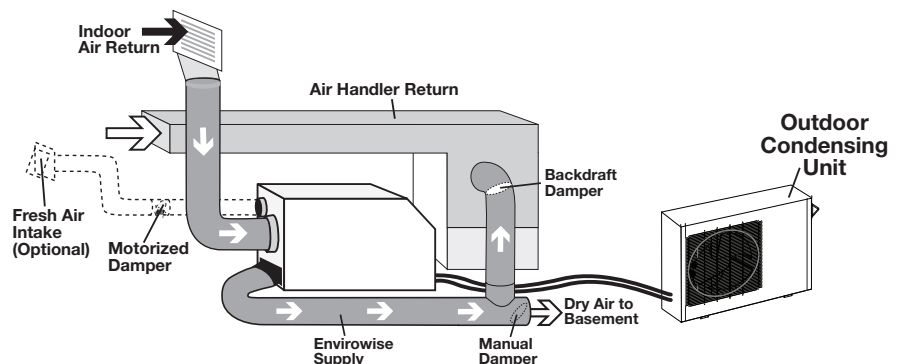

GENERAL SET UP

No Existing Ductwork Installation

When installing the Envirowise SD12 in a structure that does not have a forced air HVAC system, a single return for the Ultra Aire SD12 should be installed in a central location.

Install an insulated duct from outside to the 6" collar of the Envirowise SD12 to provide fresh air ventilation (optional).

The supply of the Envirowise SD12 should be ducted to remote areas of the structure such as bedrooms, living room, den, etc. Be sure to utilize multiple rooms to allow air inside the structure to properly circulate. Proper air distribution is important to ensure even humidity control and heat distribution throughout the structure.

Use insulated duct work on the supply duct work of the dehumidifier. A 6" diameter duct is recommended for branches to bedrooms. An 8" diameter duct is recommended for branches to larger areas.

- DO NOT locate the return in a bathroom or kitchen.
- DO NOT locate the supply in rooms where doors may be closed.
- Control should be located remotely from the dehumidifier and placed in a central location.

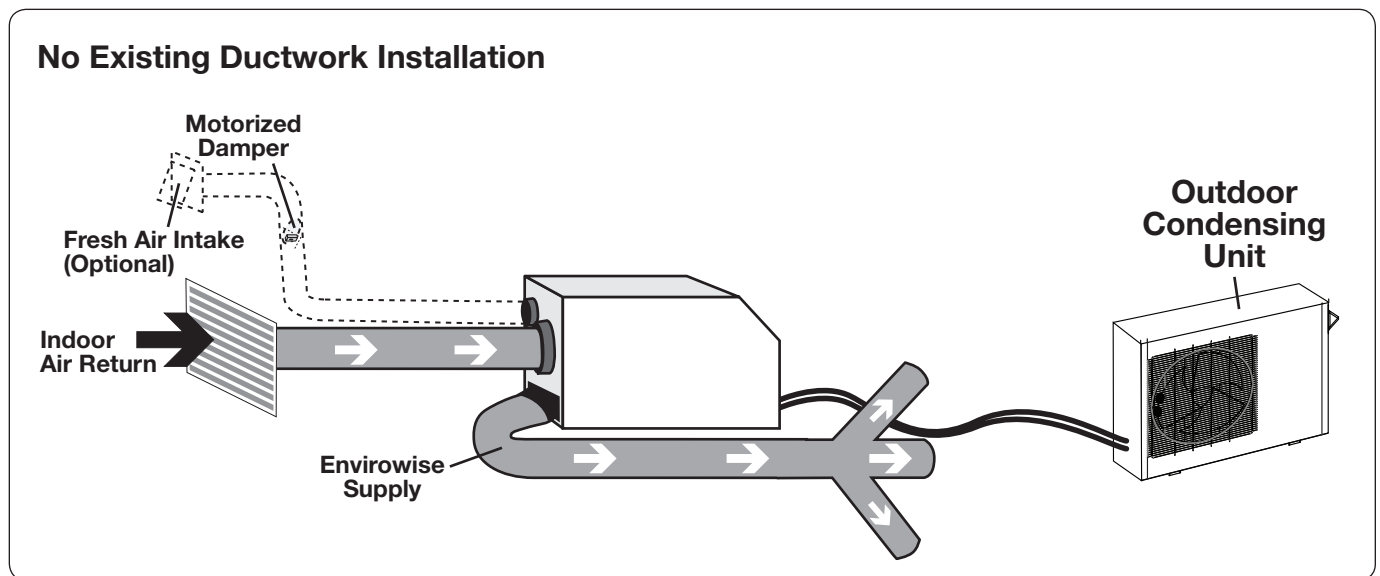

Fresh Air Ventilation

Fresh air ventilation is optional.

Fresh air may be brought into the structure by connecting an insulated duct from outside the structure to the 6" inlet of the Envirowise SD12. A ventilation control is needed to program the time and frequency that the unit introduces outside air. The time and frequency of ventilation should be based on the size and occupancy of the residence.

- The fresh air ventilation duct should be connected to the 6" round collar on the front of the Envirowise SD12.
- An insulated 6" diameter duct provides up to 150 CFM of outside air.
- If a motorized damper is not being used, fresh air is controlled by the manual damper in the 6" collar of the Envirowise SD12. Performance of the Envirowise SD12 can be impacted by inside and outside air conditions.
- When a 6" motorized damper is used, a digital control is required.
- It may be necessary to use 8" duct work if additional fresh air is required over 150 CFM.
- In cold climates or at times when the dew point is low, ventilation can be used to dehumidify the structure, making the Envirowise SD12 capable of year-round drying.

Fresh Air Ventilation With Dehumidifier Off and Dehumidifier Fan Only Operation

Outside air mixes with the dehumidifier's return air before being supplied to the home. Outside temperature, inside temperature and relative humidity will impact the combined outlet air conditions.

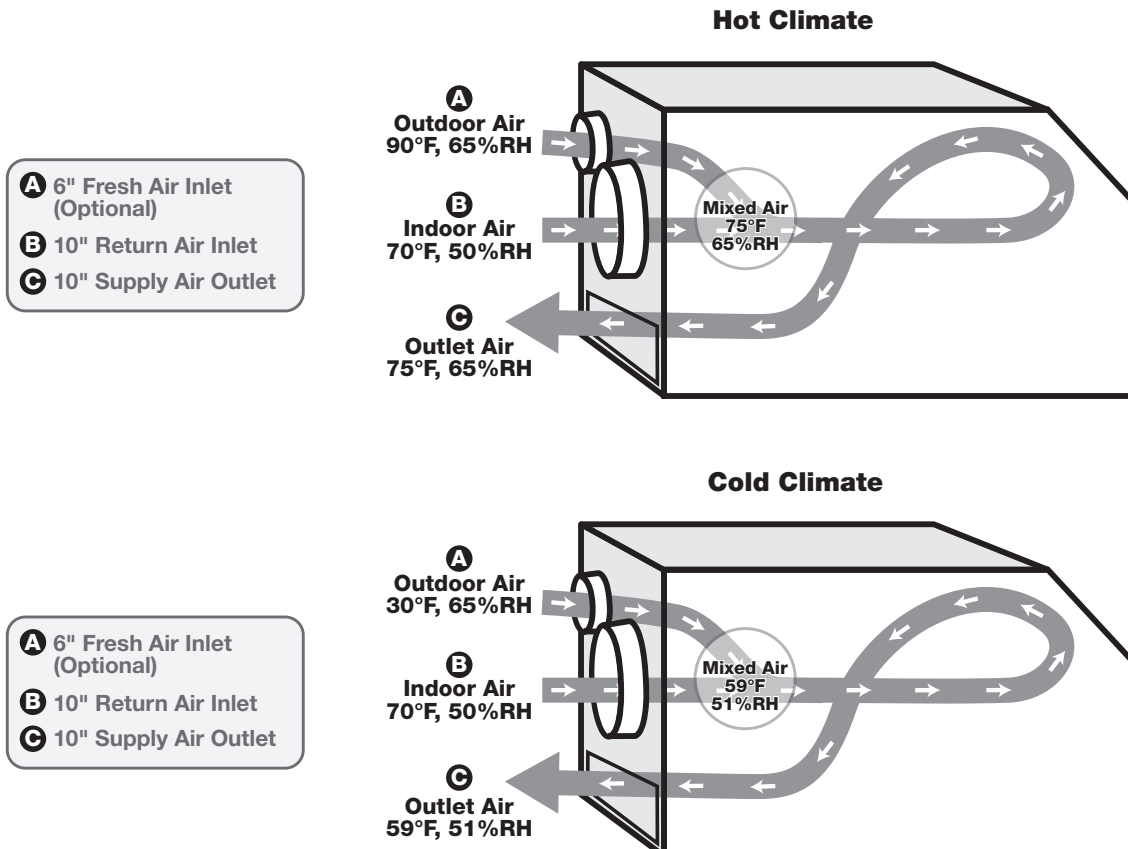

Note: Temperature and relative humidity may vary depending on duct distribution scheme.

GENERAL SET UP

Determine Ventilation Requirements

The MINIMUM ventilation requirement is calculated using ASHRAE 62.2-2016. Use one or both of the options below to determine your ventilation requirement. Follow all local and national building and safety codes.

Option 1: Calculating Airflow Requirement Using ASHRAE 62.2-2016 Airflow Equation

ASHRAE Airflow in CFM = [House Area in Sq.Ft. x 0.03] + [(Number of Bedrooms + 1) x 7.5]

NOTE: Use 'Number of Bedrooms + 1' or 'Number of Occupants', whichever is larger.

Example 1: Number of Bedrooms + 1

2500 square foot house with 3 bedrooms, 4 occupants = [2500 X 0.03] + [(3+1) X 7.5] = 105 CFM

Example 2: Number of Occupants

2500 square foot house with 3 bedrooms, 5 occupants = [2500 X 0.03] + [5 X 7.5] = 112.5 CFM

Record the required CFM _____

Option 2: Calculating Airflow Requirement Using Table 4.1 from ASHRAE 62.2-2016

Ventilation Air Requirements, CFM

Floor Area (ft ²)	Number of Bedrooms				
	1	2	3	4	5
< 500	30	38	45	53	60
501 - 1000	45	53	60	68	75
1001 - 1500	60	68	75	83	90
1501 - 2000	75	83	90	98	105
2001 - 2500	90	98	105	113	120
2501 - 3000	105	113	120	128	135
3001 - 3500	120	128	135	143	150
3501 - 4000	135	143	150	158	165
4001 - 4500	150	158	165	173	180

Table 4.1 from ASHRAE 62.2-2016

Record the required CFM _____

A control must be used with the Envirowise SD12. Nexia® Connected Controls, like the 824, 850 and 1050, have built-in dehumidification software that allows homeowners to monitor and control relative humidity and proper ventilation levels in their home. Nexia Controls are available from your installing contractor. The diagrams below show how the SD12 connects to Nexia Controls.

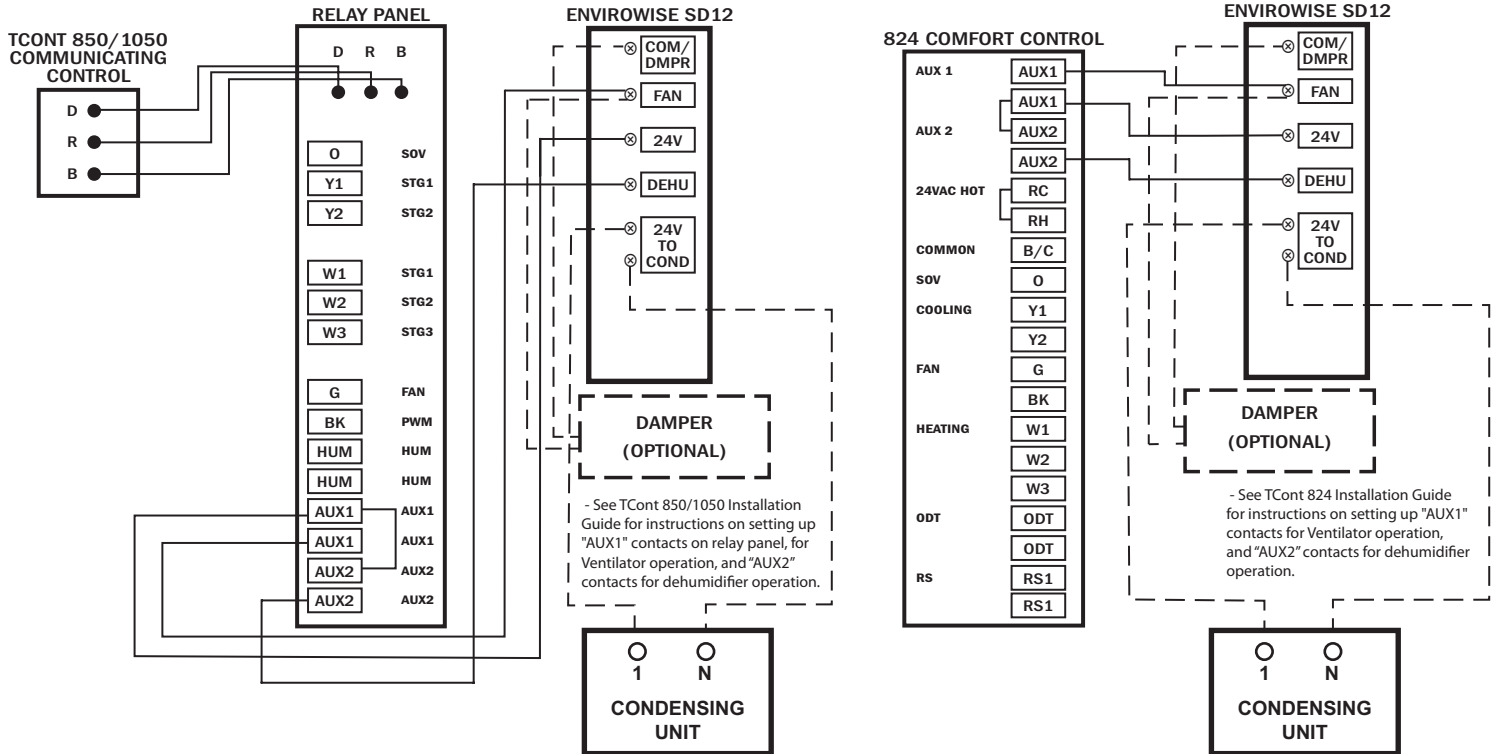

CONTROLS

A control must be used with the Envirowise SD12. Envirowise offers the D30 proprietary control. The D30 allows homeowners to monitor and control relative humidity and proper ventilation levels in their home. This control is also available with a remote sensing option.

Note: The D30 is sold as an accessory and can be purchased through your installing contractor.

Envirowise D30 Digital Control

- **Central Fan Integration** – Operates HVAC fan with dehumidifier operation.
- **A/C Sensor** – Automatically activates or deactivates the dehumidifier when the air conditioner runs.
- **High Temperature Cut-Out** – Disables dehumidifier operations if household temperature reaches the cut-out setpoint.
- **Dry-Out Cycle Timer** – Automatic fan cycling to ensure dry and clean coils.
- **Auto Reboot** – Resumes operation with prior settings in the event of power failure.

See D30 manual for detailed instructions.

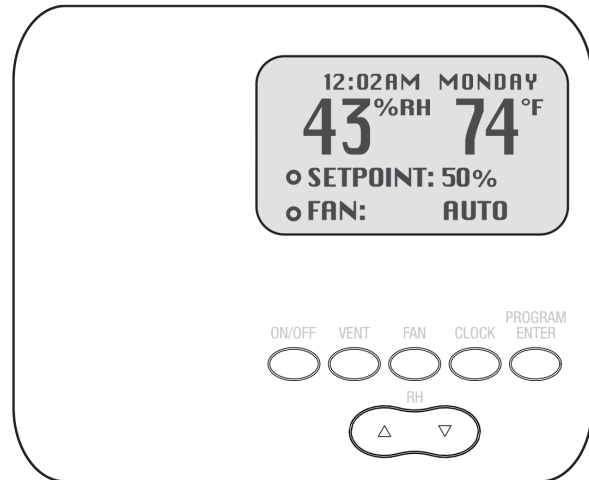

Wiring Controls

⚠ CAUTION!

DO NOT ALLOW THE 24V TERMINAL FROM THE ENVIROWISE SD12 TO CONTACT THE COM TERMINAL ON THE ENVIROWISE SD12 OR DAMAGE TO THE TRANSFORMER WILL RESULT.

Circuit Breaker

To prevent damage to the 24 volt control transformer, the Envirowise SD12 comes with a resettable circuit breaker. Check wiring for any electrical short and repair before resetting breaker. Resetting the circuit breaker without correcting the electrical short may result in transformer damage. Be sure to check the electrical schematic in this manual or inside the access panel of the Envirowise SD12 before making any control connections. The reset button for the circuit breaker can be found on the back of the unit.

Control Connections

The control and the Envirowise SD12 are labeled to prevent confusion. Depending on the control, some of the screw terminals on the Envirowise SD12 may not be used. Be sure to consult the electrical schematic in this manual or inside the access panel of the Envirowise SD12 before making control connections.

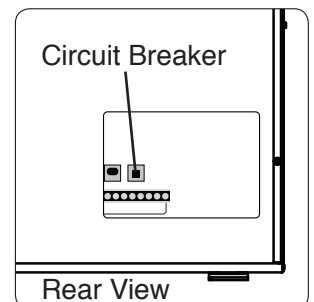

Envirowise SD12 Wired to the D30 Digital Control (Part # E4037893)

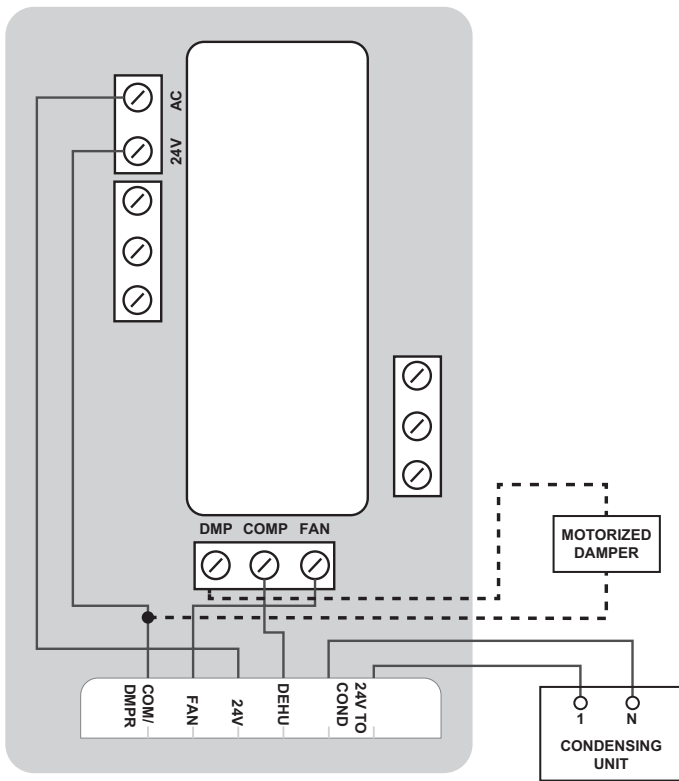

Envirowise SD12 Wired to a 2-Wire Thermal-Mechanical Dehumidistat

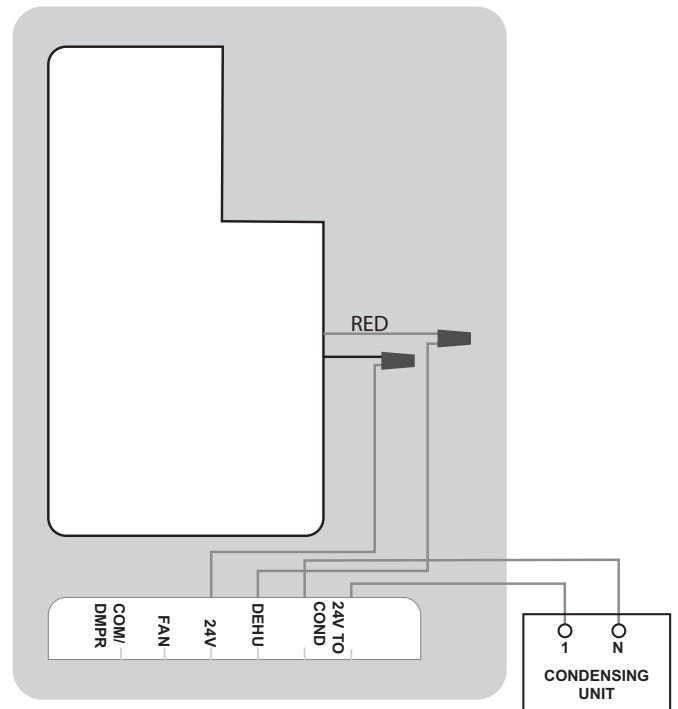

A low voltage control must be used with the Envirowise SD12.

Terminal Block Control Operation:

COM/DMPR	24VAC Power Transformer Neutral Side
FAN	Fan Control
24V	Transformer High Side
DEHU	Dehumidification (Fan and Compressor) Control
24V TO COND	24VAC Power Transformer High and Neutral Side to Condenser Unit (2 Terminals)

Between the COM lead and the 24V TERMINAL is a 40VA transformer. This low voltage power source powers the relay coils which control the fan and compressors. This 24VAC transformer can also be used to power HVAC accessories external to the dehumidifier.

Compressor ON / Fan ON	Make contact between 24V and DEHU terminals
Compressor OFF / Fan ON	Make contact between 24V and FAN terminals
Power HVAC Accessory	Connect the accessory to the COM and 24V terminals

NOTE: 18 gauge wire needed between the Envirowise SD12 dehumidifier and the external control.

FILTER INSTRUCTIONS

The Envirowise SD12 is equipped with a MERV-11 air filter. Contact your installing contractor for more information. DO NOT operate the unit without the standard MERV-11 filter. Operating the unit with no filter in place will damage the coil and may void the factory warranty.

⚠ CAUTION!

MAKE SURE UNIT IS OFF BEFORE CHANGING THE FILTER.

Changing the Filter

For greatest filtration and efficiency of the Envirowise SD12, it is recommended the air filter be replaced every three to six months with a MERV-11 filter.

Step 1: The filter door is attached to the cabinet by three hinges. Release the latch from the cabinet by pulling it towards the front of the unit. The filter door will swing open to gain access to the filter.

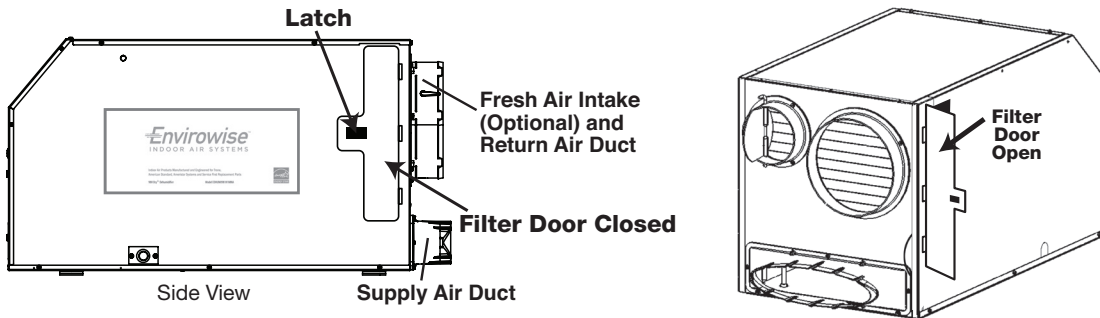

Step 2: Remove the filter by gently pulling it straight out of the unit. Insert new filter by gently pushing it straight into the unit. Make sure the AIR FLOW arrow on the filter is pointing into the unit.

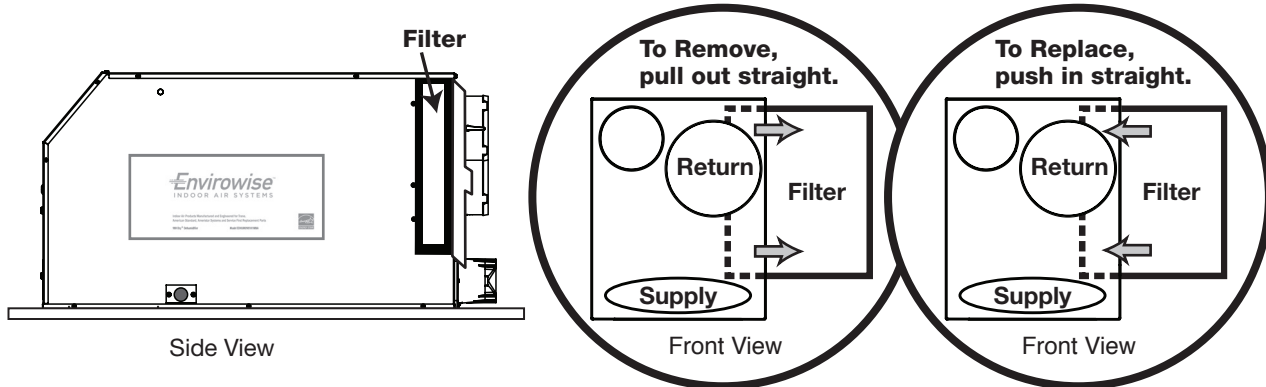

Step 3: Close the filter door by swinging it shut and reattaching the latch.

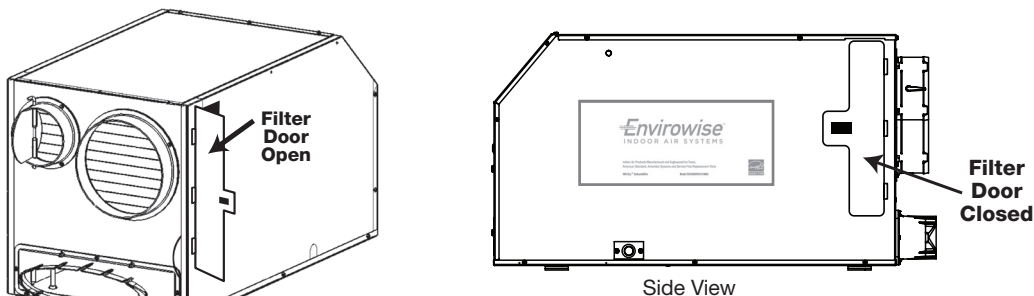

OPTIONAL ACCESSORIES

E4037893	D30 Control
E4037897	D30 Control W/ Remote
E4037878	MERV-11 Filters 4-Pack
E4037885	MERV-11 Filters 12-Pack
E4037905	Pump Kit
E4037872	Hang Kit
E4037861	6" Motorized Damper
E4037907	6" Inlet Hood
E4037865	10" Gravity Damper
E4037867	10" Oval to Round Adapter

SERVICE

Troubleshooting

⚠ CAUTION!

TROUBLESHOOTING SHOULD BE PERFORMED BY A QUALIFIED HVAC TECHNICIAN.

Symptom	Possible Reason	Troubleshooting Procedure
Neither fan nor compressor running. Dehumidification is being called for.	<ol style="list-style-type: none"> 1. Dehumidifier unplugged or no power to outlet. 2. Humidity control set too high. 3. Loose connection in internal or control wiring. 4. Defective compressor relay. 5. Defective control transformer. 	<div style="border: 1px solid black; padding: 5px; margin-bottom: 10px;"> <h3>⚠ WARNING!</h3> <p>ELECTRICAL SHOCK HAZARD: ELECTRICAL POWER MUST BE PRESENT TO PERFORM SOME TESTS. THESE TESTS SHOULD BE PERFORMED BY A QUALIFIED SERVICE PERSON.</p> </div> <p>Troubleshooting Procedure for Control Related Issues</p> <p>This method of diagnosis will test the 3 main components of the control circuit individually to indicate any potential problems. This is to be used when the control will not activate the main unit.</p> <ol style="list-style-type: none"> 1. Detach field control wiring connections from the pigtails on the main unit. 2. Jumper a wire from the 24V terminal to the FAN terminal; only the fan should run. Disconnect when complete. 3. Jumper the 24V terminal to the DEHU terminal; the fan and compressor should run. Disconnect when complete. 4. If this test works, the main unit is working correctly from a control standpoint. 5. Reconnect field control wiring to the Terminal block on the main unit. 6. Remove the control panel cover and detach the field wiring from the control connections. 7. Connect the 24V terminal and the FAN terminal wires together; the fan only should run. Disconnect when complete. 8. Jumper a wire from the 24V and DEHU terminal; fan and compressor should run. Disconnect when complete. 9. If this test works, then the field control wiring is ok. 10. If the problem persists, then the control is most likely faulty.
Compressor is not running. Dehumidification is being called for. Fan is running.	<ol style="list-style-type: none"> 1. Defective compressor run capacitor. 2. Loose connection in compressor circuit. 3. Defective compressor overload. 4. Defective compressor. 5. Defrost thermostat open. 	
Compressor cycles on and off. Dehumidification is being called for.	<ol style="list-style-type: none"> 1. Low ambient temperature and/or humidity causing unit to cycle through defrost mode. 2. Defective compressor overload. 3. Defective compressor. 4. Defrost thermostat defective. 5. Dirty air filter(s) or air flow restricted. 6. Defective fan or relay. 	

Troubleshooting (Continued)

Symptom	Possible Reason	Troubleshooting Procedure
Fan is not running. Dehumidification or fan is being called for.	<ol style="list-style-type: none"> 1. Loose connection in fan circuit. 2. Obstruction prevents fan impeller rotation. 3. Defective fan. 4. Defective fan relay. 	<div style="border: 1px solid black; padding: 5px; margin-bottom: 10px;"> <p>⚠ WARNING!</p> <p>ELECTRICAL SHOCK HAZARD: ELECTRICAL POWER MUST BE PRESENT TO PERFORM SOME TESTS. THESE TESTS SHOULD BE PERFORMED BY A QUALIFIED SERVICE PERSON.</p> </div> <p>Troubleshooting Procedure for Performance Related Issues</p> <p>This method of diagnosis is used to function check the internal components in the dehumidifier. This is to be used when a performance issue is suspected.</p> <ol style="list-style-type: none"> 1. Set the humidity controller all the way to the most humid setting or off position – Did the unit shut off? 2. If yes, turn the fan setting to the ON position – does the fan start? 3. If fan starts, leave in the fan ON position and set the humidity all the way to driest setting. May have to wait 5 minutes for the compressor to start. 4. Listen for a distinct buzzing/humming sound of a compressor starting up – do you hear this noise? 5. If compressor is running and continues to run, after about 15 minutes you should feel a slight increase in air temperature being discharged out of the discharge air side of the unit. 6. If so, depending on your environmental conditions (temp/Rh%), you should see some water production out of the hose within 30 minutes or so. <i>(Note: If the room temperature is 55 degrees or below and/or in area of low relative humidity, the dehumidifier will produce little to no water.)</i> 7. Collecting the water removed in a 24 hour period will give a measurement of performance.
Low dehumidification capacity (evaporator is frosted continuously). Dehumidification is being called for.	<ol style="list-style-type: none"> 1. Defrost thermostat loose or defective. 2. Low refrigerant charge. 3. Dirty air filter(s) or air flow restricted. 4. Excessively restrictive ducting connected to unit. 	
No ventilation. Ventilation is being called for.	<ol style="list-style-type: none"> 1. Loose connection in ventilation control circuit. 2. Loose connection in damper power circuit. 3. Defective fresh air damper. 	
Dehumidifier removes some water, but not as much as expected.	<ol style="list-style-type: none"> 1. Air temperature and/or humidity have dropped. 2. Humidity meter and/or thermometer used are out of calibration. 3. Unit has entered defrost cycle. 4. Dirty air filter(s) or air flow is restricted. 5. Defective defrost thermostat. 6. Low refrigerant charge. 7. Air leak such as loose cover or ducting leaks. 8. Defective compressor. 9. Restrictive ducting. 	

SERVICE

Troubleshooting (Continued)

CAUTION!

TROUBLESHOOTING SHOULD BE PERFORMED BY A QUALIFIED HVAC TECHNICIAN.

Symptom	Possible Reason	Troubleshooting Procedure
Control not powering dehumidifier.	<ol style="list-style-type: none">1. No power to dehumidifier.2. 24 volt circuit breaker tripped or faulty transformer.3. Loose or missing wire to the COMP Terminal on the humidity control.4. Loose or missing wire to the DEHU Terminal on the unit.5. Humidity control defective.	<div data-bbox="841 562 1458 808"><h3> WARNING!</h3><p>ELECTRICAL SHOCK HAZARD: ELECTRICAL POWER MUST BE PRESENT TO PERFORM SOME TESTS. THESE TESTS SHOULD BE PERFORMED BY A QUALIFIED SERVICE PERSON.</p></div> <ol style="list-style-type: none">1. Verify power to the unit at power outlet.2. Look for short in control wiring.3. Check wire connections at control and unit.4. Reset circuit breaker button on dehumidifier.



Ingersoll Rand (NYSE:IR) advances the quality of life by creating comfortable, sustainable and efficient environments. Our people and our family of brands—including Club Car®, Ingersoll Rand®, Thermo King® and Trane®—work together to enhance the quality and comfort of air in homes and buildings; transport and protect food and perishables; and increase industrial productivity and efficiency. We are a global business committed to a world of sustainable progress and enduring results



ingersollrand.com

Ingersoll Rand has a policy of continuous product and product data improvements and reserves the right to change design and specifications without notice. We are committed to using environmentally conscious print practices.

Envirowise and Nexia are trademarks of Trane in the United States and other countries. Energy Star is a trademark of the U.S. Environmental Protection Agency. ASHRAE is a trademark of the American Society of Heating, Refrigerating, and Air-Conditioning Engineers, Inc. All trademarks referenced are the trademarks of their respective owners.

© 2019 Ingersoll Rand. All Rights Reserved.

18-HE108D1-1-EN (JUNE 2019)
Supersedes (NEW)