

Installer's Guide

5TEM6/A5AHV 208/230V Conversion

Used with 5TEM6 / A5AHV Air Handlers to
Convert it back to 230V from 120V.

Scan the below QR code for more information.

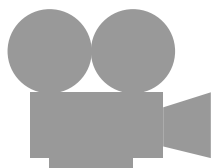

Scan to see help
videos on this
product

Note: ALL phases of this installation must comply with
NATIONAL, STATE AND LOCAL CODES.

Note: "Graphics in this document are for representation
only. Actual model may differ in appearance."

⚠ SAFETY WARNING

Only qualified personnel should install and service the equipment. The installation, starting up, and servicing of heating, ventilating, and air-conditioning equipment can be hazardous and requires specific knowledge and training. Improperly installed, adjusted or altered equipment by an unqualified person could result in death or serious injury. When working on the equipment, observe all precautions in the literature and on the tags, stickers, and labels that are attached to the equipment.

Safety Section

⚠ WARNING

HAZARDOUS VOLTAGE!

Failure to follow this Warning could result in property damage, severe personal injury, or death.

Disconnect all electric power, including remote disconnects before servicing. Follow proper lockout/tagout procedures to ensure the power cannot be inadvertently energized.

⚠ WARNING

LIVE ELECTRICAL COMPONENTS!

Failure to follow this Warning could result in property damage, severe personal injury, or death.

Follow all electrical safety precautions when exposed to live electrical components. It may be necessary to work with live electrical components during installation, testing, servicing, and troubleshooting of this product.

⚠ WARNING

GROUNDING REQUIRED!

The Cabinet must have an uninterrupted or unbroken ground according to National Electrical Code, ANSI/NFPA 70 – "latest edition" and Canadian Electrical Code, CSA C22.1 or local codes to minimize personal injury if an electrical fault should occur. Failure to follow this warning could result in an electrical shock, fire, injury, or death.

⚠ WARNING

HOT SURFACE!

Prevent all wires from touching any hot surfaces. Failure to follow this warning could result in dangerous operation, serious injury, death, or property damage.

⚠ CAUTION

DO NOT USE ELECTRIC HEATER!

Do Not Use 208/230V heater when 120V conversion kit is installed in the unit. Failure to follow this Caution could result in property damage or personal injury.

⚠ CAUTION

SHARP EDGE HAZARD!

Failure to follow this Caution could result in property damage or personal injury. Be careful of sharp edge on equipment or any other cuts made on sheet metal while installing or servicing.

Table of Contents

Application 4
Installation Instructions for Converting
the unit back to 208/230V 5

Wiring Diagram 12
Check List 14

Application

This procedure is to uninstall BAYAH120VKT and convert 5TEM6/A5AHV unit to factory configuration. With these steps customers can use 208/230V field supply to power up the AHU.

Installation Instructions for Converting the unit back to 208/230V

Prerequisite before converting the unit to 230V:

- Use 230/24V Transformer that was retained earlier during 120V conversion. If it is not available/damaged, the same can be ordered by TRR01557 at Trane part store.
- Use Jumper that was retained earlier during 120V conversion. If it is not available, the same can be ordered by WIR13821 at Trane part store.
- Use Male 6-pin polarized plug-Red and Black, that was retained earlier during 120V conversion or the Male 6-Pin polarized plug from heater, for heater installation.

Follow the steps below to convert the 5TEM6/A5AHV units with 120V conversion kit to a standard 208/230V primary, 24V secondary transformer operating unit.

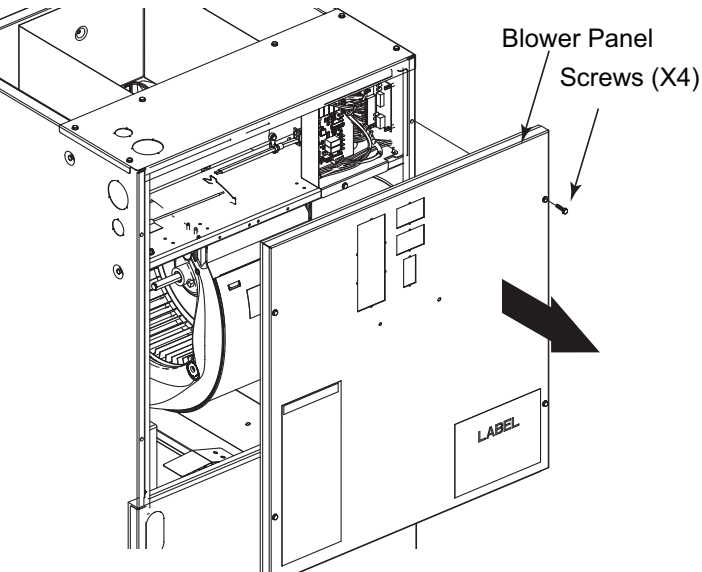
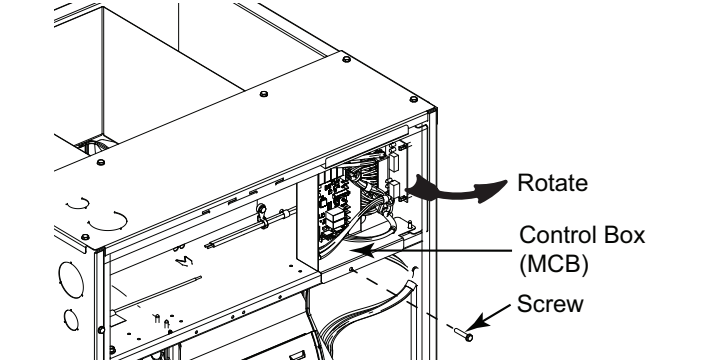
<ol style="list-style-type: none">1. Disconnect the power supply of the unit.2. Remove the Front Blower Panel to get access to the Control Panel.	 <p>Blower Panel Screws (X4)</p>
<ol style="list-style-type: none">3. Remove the screw that attaches Control Board (MCB) to the frame.4. Rotate the Control Board (MCB) clockwise to get access to the backside of the controls.	 <p>Rotate Control Box (MCB) Screw</p>

Installation Instructions for Converting the unit back to 208/230V

5. Disconnect the male **6-pin polarized plug** with White and Black wire from the unit.

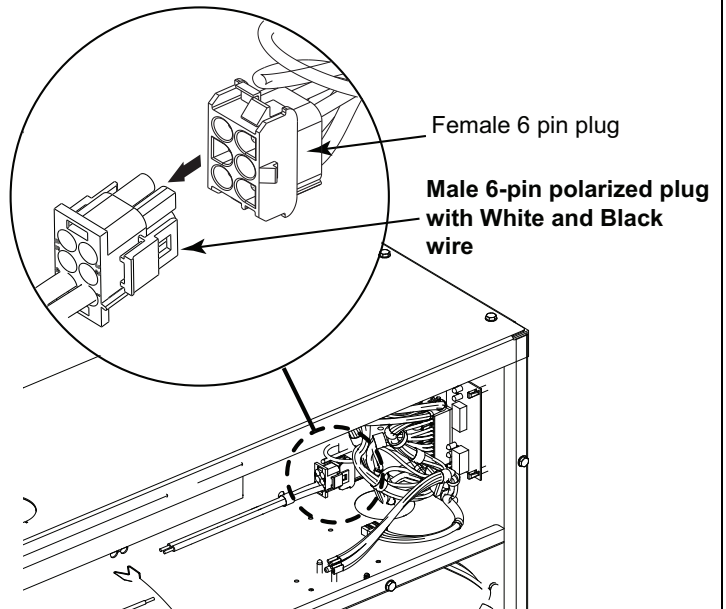
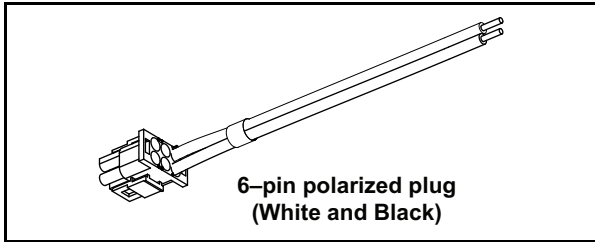

Note: The Mitigation Control Board Box is not shown for clarity.

6. Disconnect the **Line Choke** terminals from the Red wires.

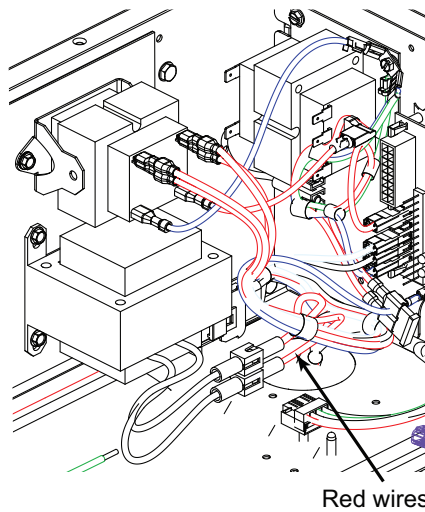

Installation Instructions for Converting the unit back to 208/230V

7. Disconnect the Blue wire from one end and Blue & Green/Yellow wire (Crimped Together in one terminal) from the other end of the **Ground Terminal**.

Note: Refer Wiring Diagram (Figure 2) for detailed wiring information.

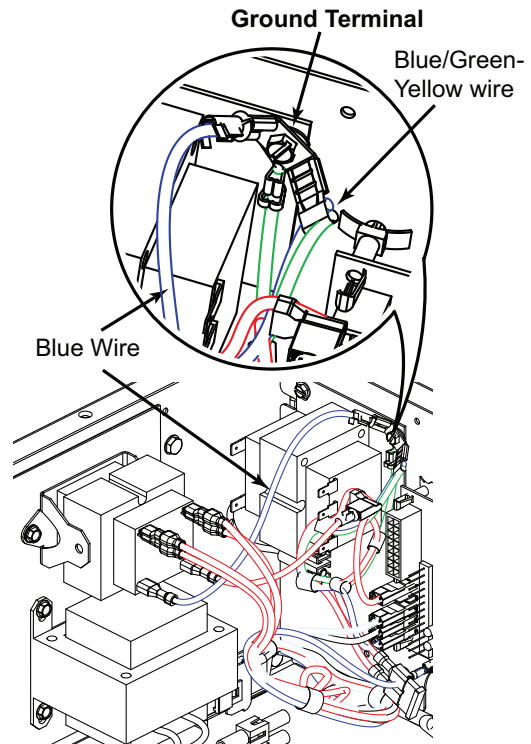

8. Disconnect the Red 24V Wire from **35VA 120/24V Transformer** and the Red Wire of the unit Harness (From Fuse).

Note: Refer Wiring Diagram (Figure 2) for detailed wiring information.

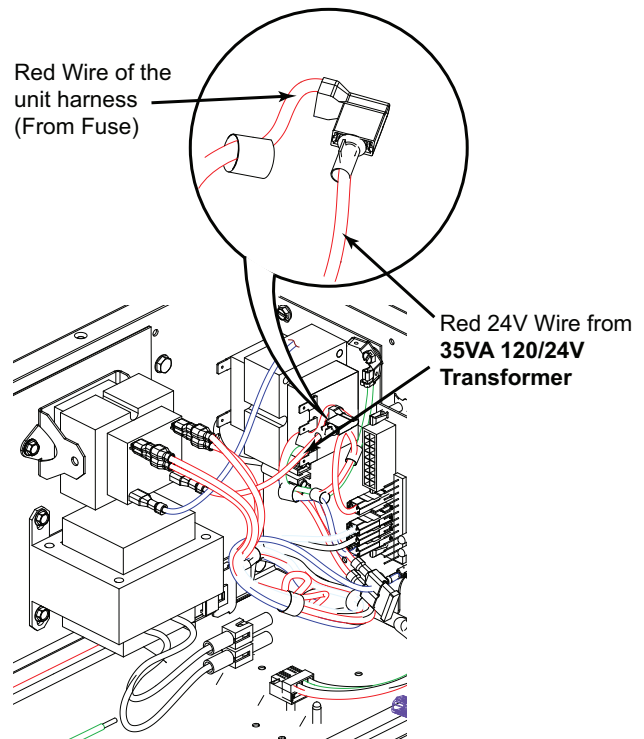

Installation Instructions for Converting the unit back to 208/230V

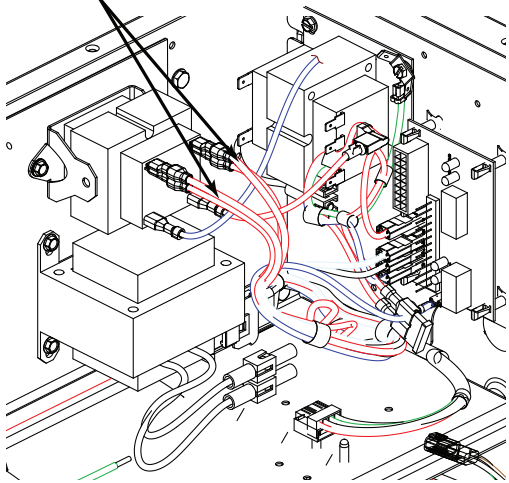
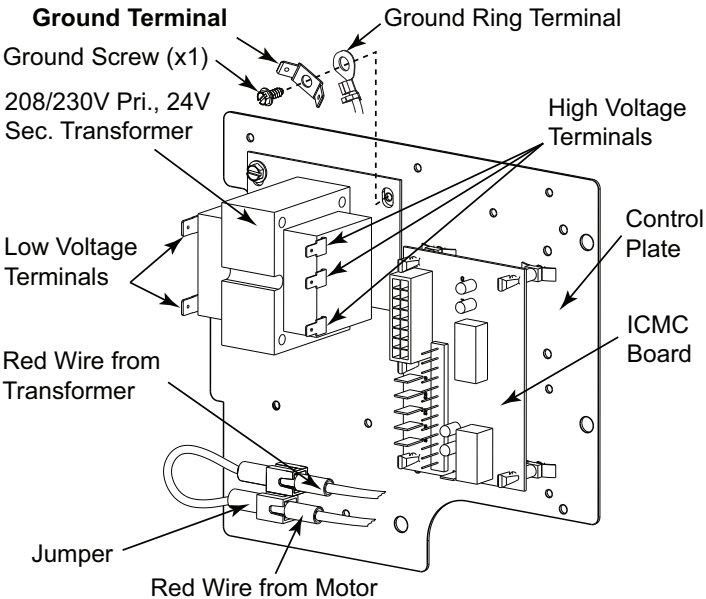
<p>9. Disconnect the High Voltage Harness (Black and Red) wires from the Primary side terminals of the 35VA 120/24V Transformer.</p>	<p style="text-align: center;">High Voltage Harnesses</p> 
<p>10. Connect the harnesses removed from 35VA 120/24V Transformer to 230/24V Transformer (High Voltage & Low Voltage Terminal). Also, remove the Ground Terminal.</p> <p>11. Connect back the retained Jumper to its position as shown in figure and Wiring Diagram.</p> <p>Note: Refer Wiring Diagram (Figure 1) for detailed wiring information.</p>	 <p style="text-align: center;">Note: Full unit is not shown for better view.</p>

12. Once all the harnesses are connected to 230V/24V transformer, unscrew the **35VA 120/24V Transformer** and **Line Choke** from Heater Knock-out Plate.

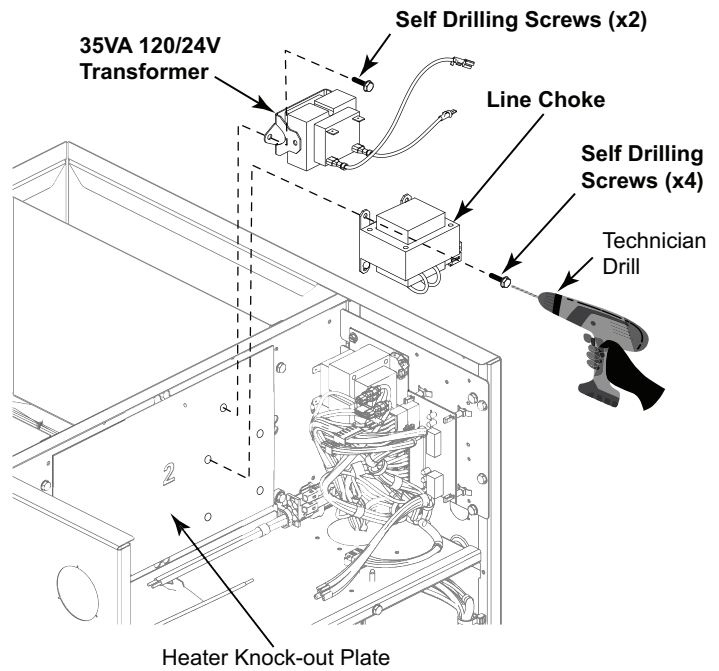

13. Connect the Male 6-pin polarized plug with Red and Black wire to the female 6-pin plug or connect to the Male 6-Pin polarized plug from heater, if heater to be installed.

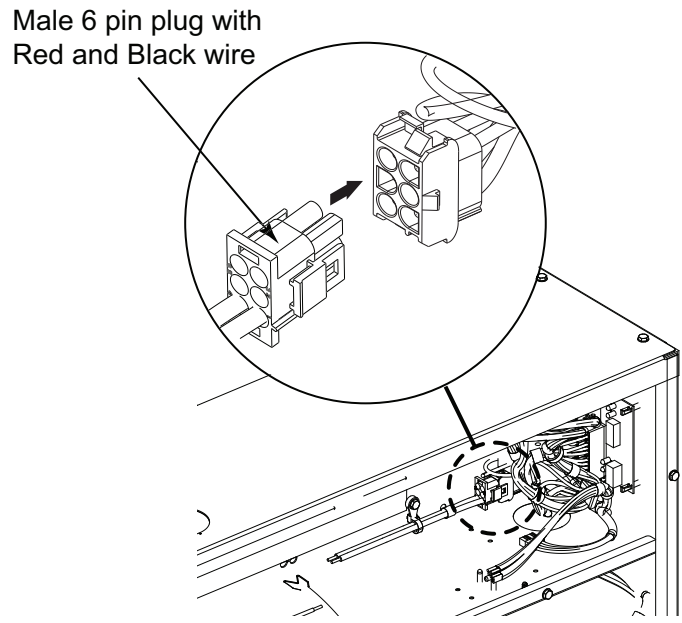

Installation Instructions for Converting the unit back to 208/230V

14. Re-attach the Control Box (MCB) to the frame using the screw that was removed earlier in the Step 3.

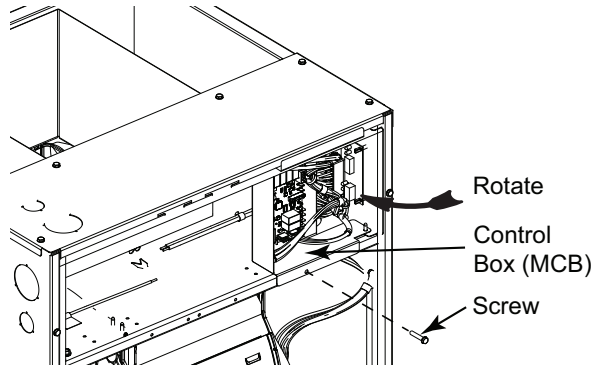

15. Remove the **120V Adapter Harness for Motor**.
16. Directly plug—in the High Voltage Harness (Red and Black) male connector to the motor as shown in **Remove 120V Adapter Harness from Motor**.

Unit Connection with BAYAH120VKT

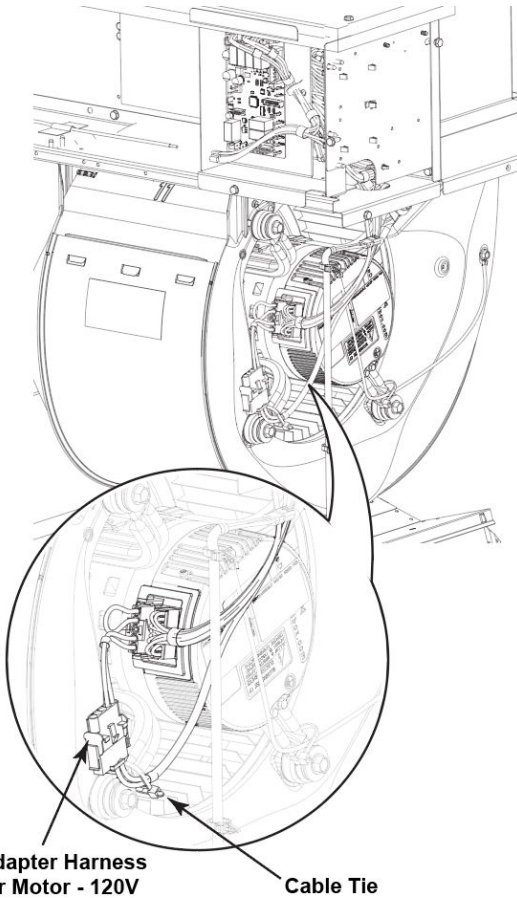

Remove 120V Adapter Harness from Motor

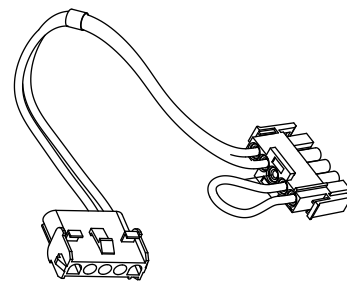
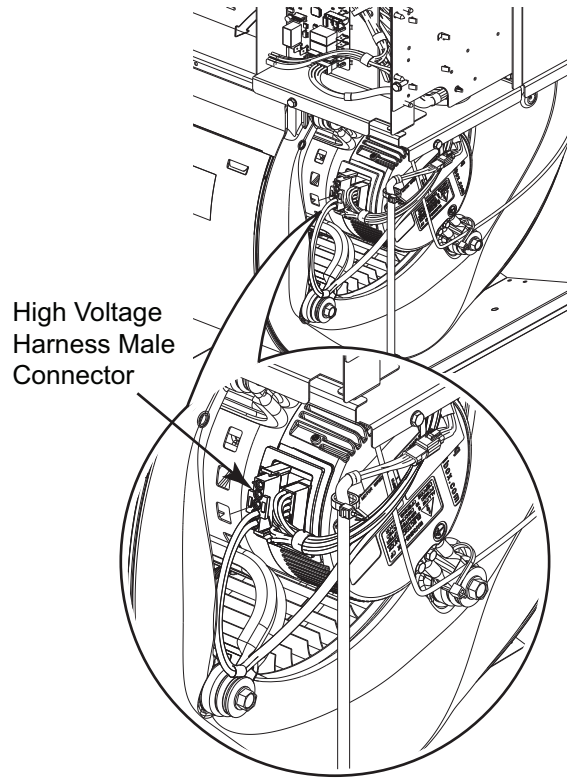

**Adapter Harness for
Motor - 120V**

Installation Instructions for Converting the unit back to 208/230V

17. Secure back the Front Blower Panel.
18. Remove the **120V conversion label** from the Front Blower Panel and the unit is now ready for the 230V field application.

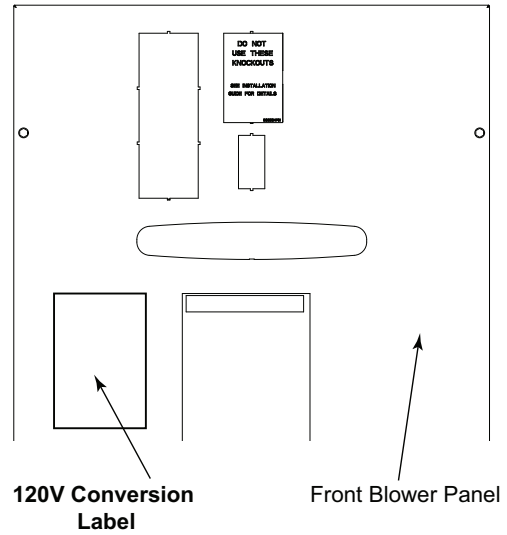

Check List

Check List to follow after Kit removal for 208/230V application:

1. Ensure 35VA 120/24V transformer is removed.
2. Ensure the line choke is removed.
3. Check the wire harnesses are connected to the correct terminals of the components by verifying with the wiring diagram as shown in Figure 1.
4. Ensure the 120V adapter harness for motor is removed.
5. Ensure the 120V conversion label is removed from the front blower panel.

About Trane and American Standard Heating and Air Conditioning

Trane and American Standard create comfortable, energy efficient indoor environments for residential applications. For more information, please visit www.trane.com or www.americanstandardair.com.



The manufacturer has a policy of continuous data improvement and it reserves the right to change design and specifications without notice. We are committed to using environmentally conscious print practices.

18-GJ97D1-1C-ADD-EN 12 Dec 2024

Supersedes 18-GJ97D1-1B-ADD-EN (November 2024)

©2024