

# Installer's Guide

## Variable Speed Air Handlers Convertible 2 – 5 Ton

TAM9A0A24V21DB  
TAM9A0B30V31DB  
TAM9A0C36V31DB  
TAM9A0C42V41DB  
TAM9A0C48V41DB  
TAM9A0C60V51DB

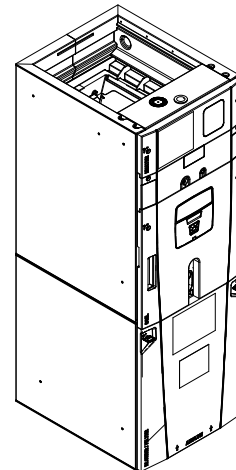

*Note: "Graphics in this document are for representation only. Actual model may differ in appearance."*

*Note: For use with BAYEA series heaters ONLY*

### **▲ SAFETY WARNING**

Only qualified personnel should install and service the equipment. The installation, starting up, and servicing of heating, ventilating, and air-conditioning equipment can be hazardous and requires specific knowledge and training. Improperly installed, adjusted or altered equipment by an unqualified person could result in death or serious injury. When working on the equipment, observe all precautions in the literature and on the tags, stickers, and labels that are attached to the equipment.

# SAFETY SECTION

**Important** — This document contains a wiring diagram, a parts list, and service information. This is customer property and is to remain with this unit. Please return to service information pack upon completion of work.

## ⚠ WARNING

### HAZARDOUS VOLTAGE!

Failure to follow this Warning could result in property damage, severe personal injury, or death.

Disconnect all electric power, including remote disconnects before servicing. Follow proper lockout/tagout procedures to ensure the power cannot be inadvertently energized.

## ⚠ CAUTION

### GROUNDING REQUIRED!

Failure to inspect or use proper service tools may result in equipment damage or personal injury. Reconnect all grounding devices. All parts of this product that are capable of conducting electrical current are grounded. If grounding wires, screws, straps, clips, nuts, or washers used to complete a path to ground are removed for service, they must be returned to their original position and properly fastened.

## ⚠ WARNING

### LIVE ELECTRICAL COMPONENTS!

Failure to follow this Warning could result in property damage, severe personal injury, or death.

Follow all electrical safety precautions when exposed to live electrical components. It may be necessary to work with live electrical components during installation, testing, servicing, and troubleshooting of this product.

## ⚠ WARNING

### PRESSURIZED REFRIGERANT!

Failure to follow this Warning could result in personal injury

System contains oil and refrigerant under high pressure. Recover refrigerant to relieve pressure before opening the system. Do not use non-approved refrigerants or refrigerant substitutes or refrigerant additives.

## ⚠ CAUTION

### SHARP EDGE HAZARD!

Failure to follow this Caution could result in property damage or personal injury.

Be careful of sharp edges on equipment or any cuts made on sheet metal while installing or servicing.

## ⚠ WARNING

### WARNING!

This product can expose you to chemicals including lead, which are known to the State of California to cause cancer and birth defects or other reproductive harm. For more information go to [www.P65Warnings.ca.gov](http://www.P65Warnings.ca.gov).

**Important:** Panel damage can occur with prolonged exposure to POE lubricants. Air handler front panels that come in contact with POE oil must be washed immediately with soapy water.

**Important:** The TAM9 air handlers are only compatible with BAYEA\*\* internal electric heaters.

**Note:** Representative illustrations only included in this document. Most illustrations display the upflow configuration.

# Table of Contents

Installer Guide Notes .....	4	Refrigerant System Layout .....	18
Unit Design.....	5	Refrigerant Line Brazing .....	19
Filters.....	6	Condensate Drain Piping .....	21
Unit Install Preparation .....	7	Electrical — Low Voltage .....	23
Optional Accessories .....	7	Control Panel Reinstallation .....	27
Optional Cabinet Disassembly.....	8	Electrical — High Voltage.....	28
Placing Unit at Location .....	10	Outline Drawing .....	30
Unit Location Considerations.....	11	Display Assembly / Human	
Four-Way Conversion.....	11	Interface .....	31
Ducted and Non-Ducted Return		TAM9 — Technician Menu and	
Applications.....	12	Configuration tree .....	32
Additional Unit Preparation		Start Up .....	37
Considerations .....	13	System Charge Adjustments .....	37
Setting the Unit — Vertical		<b>System Start Up</b> .....	37
Installation .....	14	Sequence of Operation .....	38
Setting the Unit — Horizontal		Abbreviations .....	38
Installations .....	16	Fault Reporting.....	39
Connecting the Duct work .....	17	Checkout Procedures .....	40
Refrigerant Line .....	18		

# Installer Guide Notes

**ALL Phases of this installation must comply with NATIONAL, STATE and LOCAL CODES!**

**Important:** This Document is customer property and is to remain with this unit. Please return to service information upon completion of work

**Important:** These instructions do not cover all variations in systems nor provide for every possible contingency to be met in connection with the installation. Should further information be desired or should particular problems arise which are not covered sufficiently for the purchaser's purposes, the matter should be referred to your installing dealer.

**See TAM9 Service Facts document for information on reading the Display, Air Flow Tables and Troubleshooting Flowcharts.**

**Important:** The low voltage wire harness is shipped in the supplied document pack.

**Note:** The manufacturer recommends installing ONLY A.H.R.I. approved, matched indoor and outdoor systems. Some of the benefits of installing approved matched indoor and outdoor split systems are maximum efficiency, optimum performance, and the best overall system reliability.

**Note:** Condensation may occur on the surface of the air handler when installed in unconditioned spaces, verify that all electrical and refrigerant line penetrations on the air handler are sealed completely.

The TAM9 air handlers will only use the following internal electric heaters:

BAYEAAC04BK1	BAYEAAC10LG1
BAYEAAC04LG1	BAYEAAC10LG3
BAYEAAC05BK1	BAYEABC15BK1
BAYEAAC05LG1	BAYEABC15LG3
BAYEAAC08BK1	BAYEABC20BK1
BAYEAAC08LG1	BAYEACC25BK1
BAYEAAC10BK1	

**Note:** Duct heaters cannot be applied with this air handler.

**Note:** The heater size needs to be configured in the Configuration Menu.

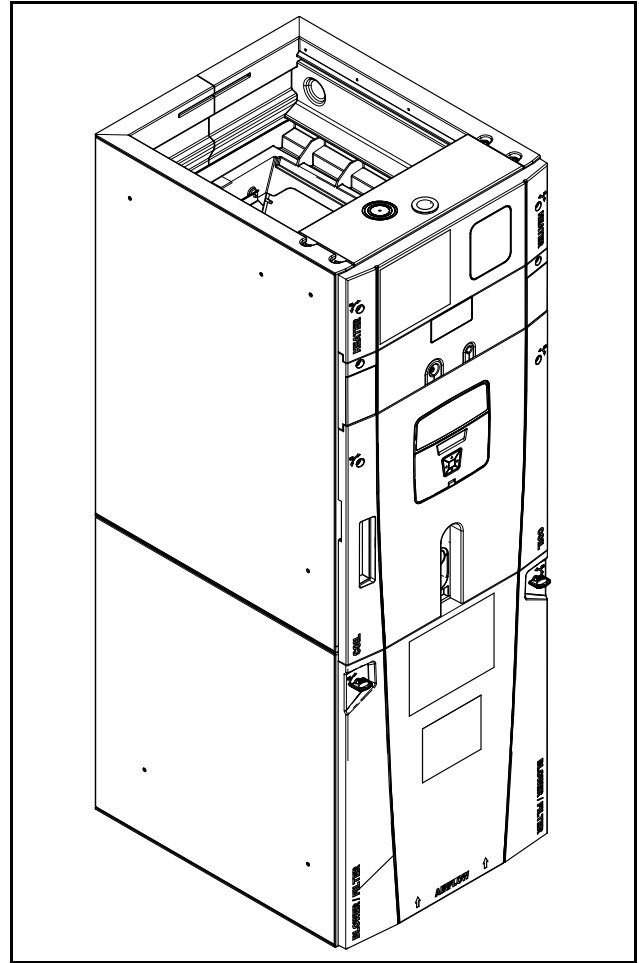

# Unit Design

## Cabinet Penetration

**Important:** Due to the unique design of this unit, which allows the electrical wiring to be routed within the insulation, do not screw, cut, or otherwise puncture the unit cabinet in any location other than the ones illustrated.

**Important:** Under no conditions should metal strapping be attached to the unit to be used as support mechanisms for carrying or suspension purposes.

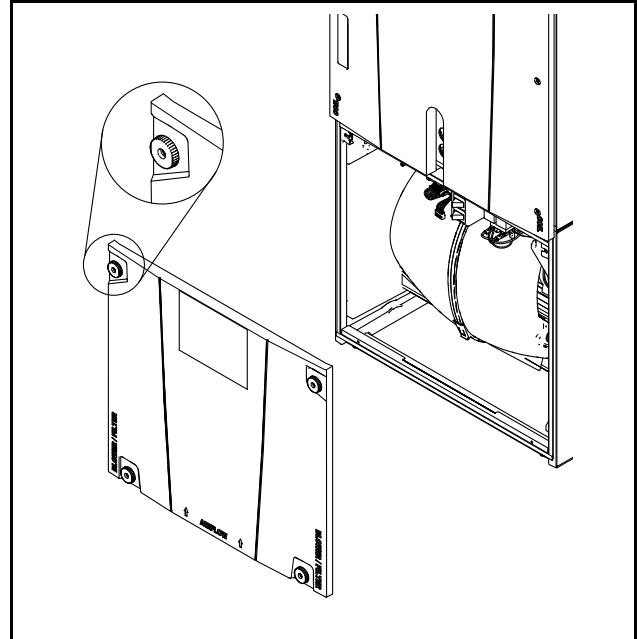
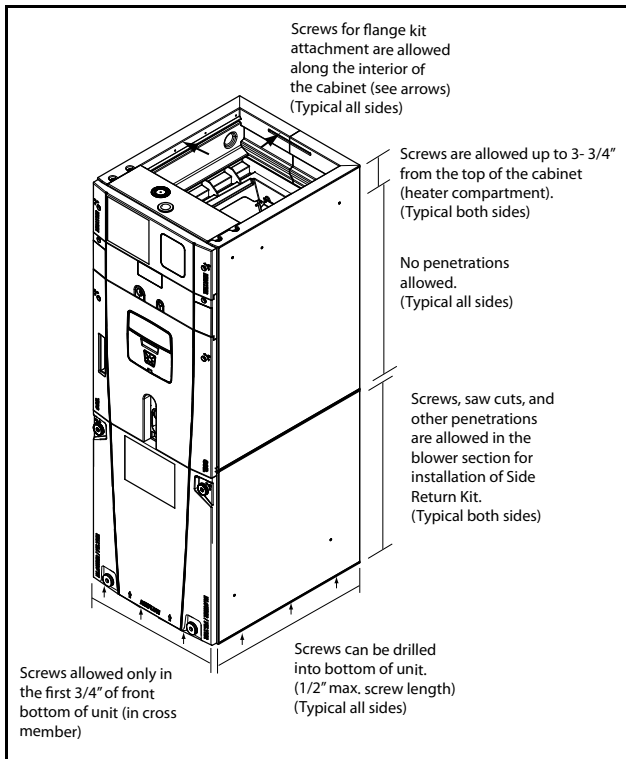

The Coil, Line Set, and Heater panels are removed using Phillips head screws.

Removal requires #3 Size Phillips

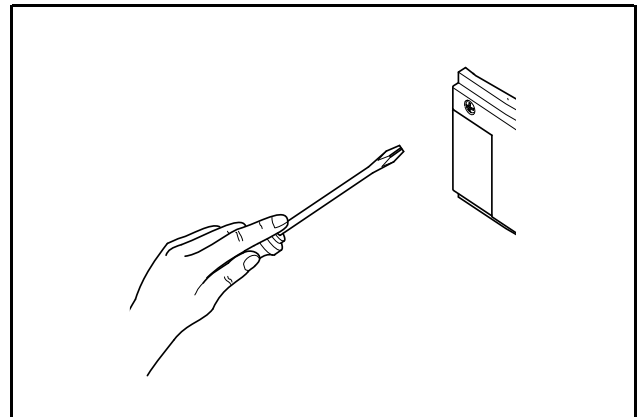

## Panel Removal

The unit contains four (4) access panels: Blower/Filter, Coil, Line Set, and Heater.

The Blower/Filter panel is removed using 1/4 turn thumb screws.

1. Turn thumb screws on Blower/Filter panel.
2. Pull top of panel out, away from cabinet.
3. Lift panel up out of channel.
4. Set aside.

Coil and Heater panels must be removed prior to removing the Line Set panel.

To remove Coil Panel:

1. Turn screws on Coil panel.
2. Rotate bottom of panel away from cabinet.
3. Disconnect the plug from the door to the unit.
4. Remove panel from channel.
5. Set aside.

## Unit Design

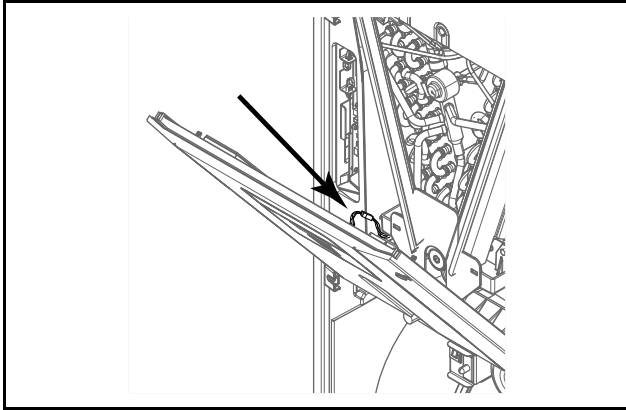

To remove Heater Panel:

1. Turn screws on Heater panel.
2. Pull panel straight out, away from cabinet.
3. Set aside.

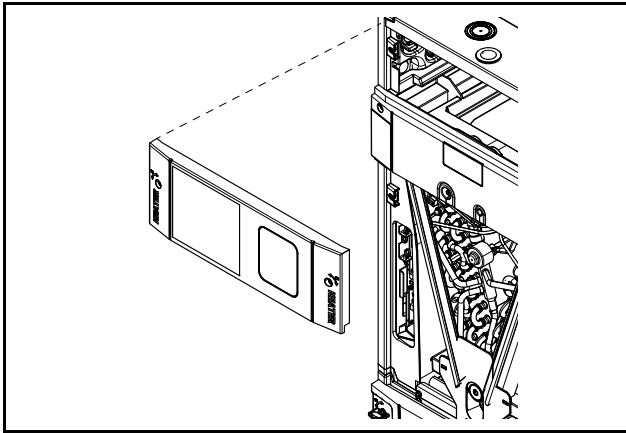

Removal of the Line Set panel is required for all refrigerant line brazing and some condensate line assembly depending on your orientation.

To remove Line Set panel:

1. Remove both Heater and Coil panels.
2. Turn screws on Line Set panel.
3. Pull panel straight out, away from cabinet.
4. Set aside.

**Note:** After replacing all panels, loosen the Line Set panel screws approximately 1/4 – 1/2 turn. This will improve the seal between the Heater Panel and Line Set panel.

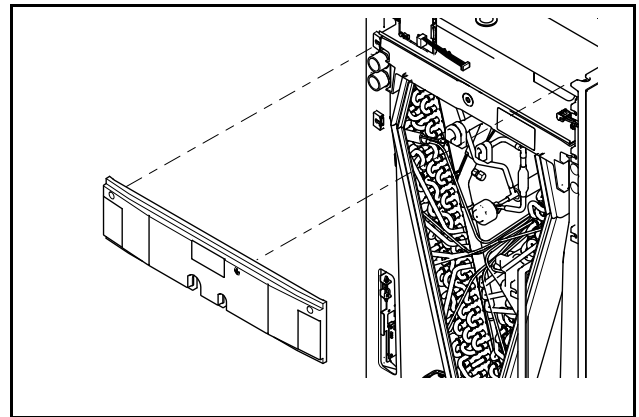

## Filters

**Table 1. Filter Considerations**

- A filter must be installed within the system.
- A filter channel is provided in the unit at the bottom of the Blower/Filter compartment.
- For customer ease of filter maintenance, it is recommended that a properly sized remote filter grill(s) be installed for units that are difficult to access. Airflow should not exceed the maximum rated velocity of the filter being used.

**Table 2. Filter Sizes**

Cabinet Size *	A	B	C
Filter Size	16 x 20	20 x 20	22 x 20
* Cabinet size is indicated by the 7th digit in model number.			

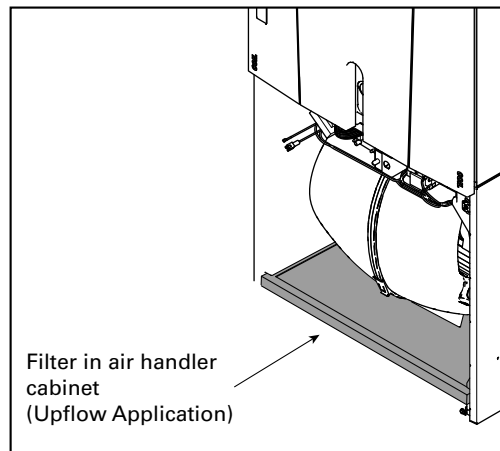

# Unit Install Preparation

1. Check for damage and report promptly to the carrier any damage found to the unit.

**Note:** If the unit must be transported in a horizontal position, it must be laid on its back (marked "REAR" on carton).

**Note:** After unit is removed from the carton, verify coil is pressurized. Carefully remove the liquid line plug. If no pressure is released, check for leaks.

**Note:** Remove the cardboard from the bottom of the blower. Cut the tie wrap and remove the foam shipping block located at the motor.

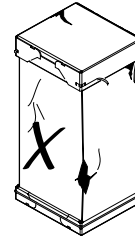

## Optional Accessories

Accessory Number	Description	Fits Cabinet Size (a)
BAYEAAC04BK1	Electric Heater, 4kW, Breaker, 24V Control, 1 Ph	A to C
BAYEAAC04LG1	Electric Heater, 4kW, Lugs, 24VControl, 1 Ph	A to C
BAYEAAC05BK1	Electric Heater, 5kW, Breaker, 24V Control, 1 Ph	A to C
BAYEAAC05LG1	Electric Heater, 5kW, Lugs, 24VControl, 1 Ph	A to C
BAYEAAC08BK1	Electric Heater, 8kW, Breaker, 24V Control, 1 Ph	A to C
BAYEAAC08LG1	Electric Heater, 8kW, Lugs, 24VControl, 1 Ph	A to C
BAYEAAC10BK1	Electric Heater, 10kW, Breaker, 24V Control, 1 Ph	A to C
BAYEAAC10LG1	Electric Heater, 10kW, Lugs, 24VControl, 1 Ph	A to C
BAYEABC15BK1	Electric Heater, 15kW, Breaker, 24V Control, 1 Ph	B to C
BAYEABC20BK1	Electric Heater, 20kW, Breaker, 24VControl, 1 Ph	C
BAYEACC25BK1	Electric Heater, 25kW, Breaker, 24V Control, 1 Ph	C
BAYEAAC10LG3	Electric Heater, 10kW, Lugs, 24VControl, 3 Ph	A to C
BAYEABC15LG3	Electric Heater, 15kW, Lugs, 24V Control, 3 Ph	B to C
BAYSUPFLGAA	Supply Duct Flange A	A
BAYSUPFLGBA	Supply Duct Flange B	B
BAYSUPFLGCA	Supply Duct Flange C	C
BAYRETLGAA	Return Duct Flange A	A
BAYRETLGBA	Return Duct Flange B	B
BAYRETLGCA	Return Duct Flange C	C
BAYSRKIT100A	Side Return Kit	A to C
BAYFLR1620A	High Velocity Filter Kit, 16" x 20" x 1" (10 filters)	A
BAYFLR2020A	High Velocity Filter Kit, 20" x 20" x 1" (10 filters)	B
BAYFLR2220A	High Velocity Filter Kit, 22" x 20" x 1" (10 filters)	C
TASB175SB (b) (c)	Plenum Stand with integrated sound baffle A	A
TASB215SB	Plenum Stand with integrated sound baffle B	B
TASB235SB	Plenum Stand with integrated sound baffle C	C
MITISRKIT01A	Side Return Kit with 16" x 20" Filter	A to C
BAYFRKIT175	Front Return Kit for 17.5" Cabinet	A
BAYFRKIT210	Front Return Kit for 21.0" Cabinet	B
BAYFRKIT235	Front Return Kit for 23.5" Cabinet	C
TAYBASETAMA	Downflow Sub-Base Kit	A to C
BAYBAFKT175A (d)	Sound Baffle Kit for 17.5" Cabinet	A
BAYBAFKT215A	Sound Baffle Kit for 21.0" Cabinet	B
BAYBAFKT235A	Sound Baffle Kit for 23.5" Cabinet	C
TASSBK175 (e) (f)	Sound Baffle Kit for 17.5" Cabinet	A
TASSBK210	Sound Baffle Kit for 21.0" Cabinet	B
TASSBK235	Sound Baffle Kit for 23.5" Cabinet	C
BAYICKSKIT01A	Internal Condensate Switch Kit	A to C
BAYHHKIT001A	Horizontal Hanger Kit	A to C
BAYUVCLK001A	UV Lights	A to C
BAYLVKIT100A	Low Voltage Conduit Entry Kit	A to C
BAYSPEKT200A	Single Power Entry Kit	A to C
BAYWAAA05SC1AA	Hydronic Coil — 50,000 BTUH — Slide-in	A to A
BAYWABB075SC1AA	Hydronic Coil — 70,000 BTUH — Slide-in	B to B
BAYWACC085SC1AA	Hydronic Coil — 80,000 BTUH — Slide-in	C to C
BAYWACC115SC1AA	Hydronic Coil — 100,000 BTUH — Add on	C to C
BAYWAKIT24VAC	Hydronic Heater Relay Kit — (used in Communicating mode only)	A to C
BAYINSKT175A	Solcoustic® Liner Kit for 17.5" cabinet	A
BAYINSKT215A	Solcoustic® Liner Kit for 21.5" cabinet	B
BAYINSKT235A	Solcoustic® Liner Kit for 23.5" cabinet	C
BAYCNDPIP01A	3/4" PVC Threaded Pipe Kit foam Seal (10 per box)	A to C
BAYAHEMIKIT001A	EMI/EFI Air Handler Electronic noise kit for variable speed blower motor	A to C

(a) A Cabinet is 17.5" wide, B Cabinet is 21.5" wide, C Cabinet is 23.5" wide.

(b) Contact your distributor for information.

(c) In open air applications, the plenum stand with sound baffle provides sound reduction.

(d) Mounts inside air handler filter channel.

(e) In return plenum applications, use TASSBK for sound reduction.

(f) Mounts to TASB original plenum stand without integrated baffle.

# Optional Cabinet Disassembly

**Note:** If the unit must be transported in a horizontal position, it must be laid on its back (marked "REAR" on carton).

**Note:** To reassemble cabinet, follow the steps in reverse order. Ensure electrical connections are secure and the plug clips are engaged.

1. Remove all four front panels.
2. Remove the two screws on the seal bar and pull the seal bar straight out.
3. Disconnect all wiring connections routed to the blower assembly.

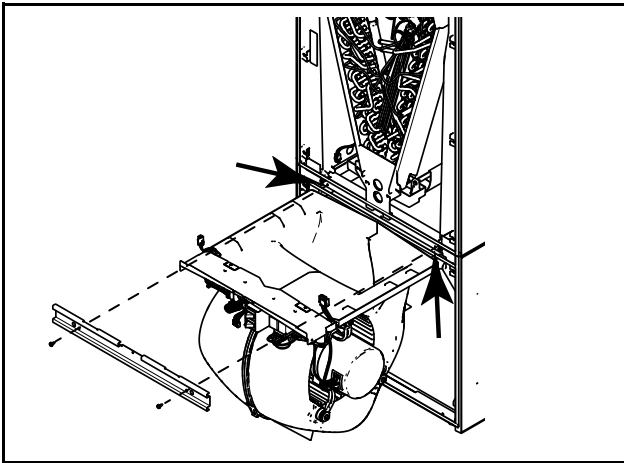

4. Slide Blower assembly out of unit using built-in blower support channels and set aside.

**Note:** Remove the cardboard from the bottom of the blower. Cut the tie wrap and remove the foam block located at the motor.

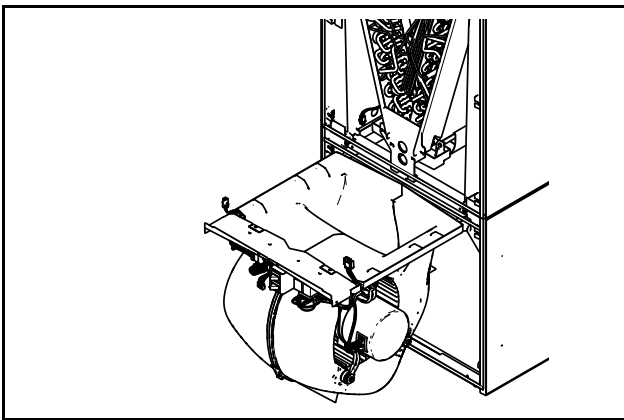

5. Disconnect wires to the EEV motor and sensors. Cut the wire ties on those wire harnesses if necessary and replace after re-installing.

**Note:** If cut, wire ties that held the sensor must be replaced after the coil is placed back into the cabinet.

6. Slide Coil assembly out of unit using built-in coil support channels and set aside

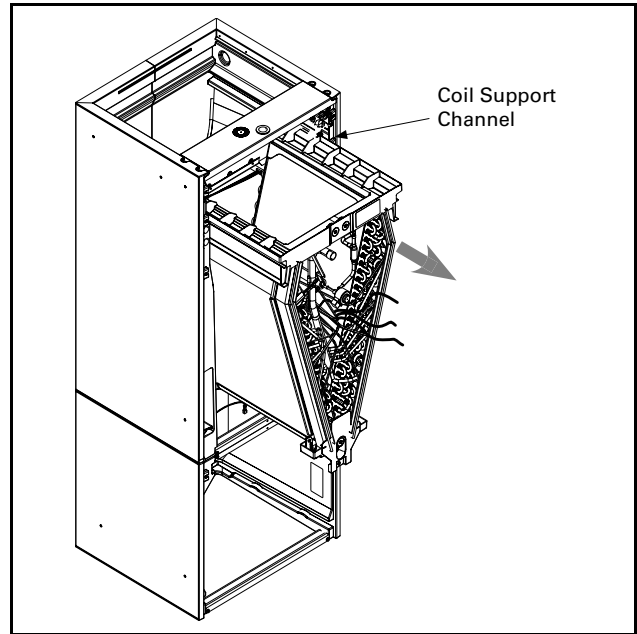

7. Use a 5/16 Allen wrench on the locking mechanism on each side of the bottom half of the cabinet to loosen the locking mechanism. The locks loosen by turning counter-clockwise approximately 3/4 of a turn.

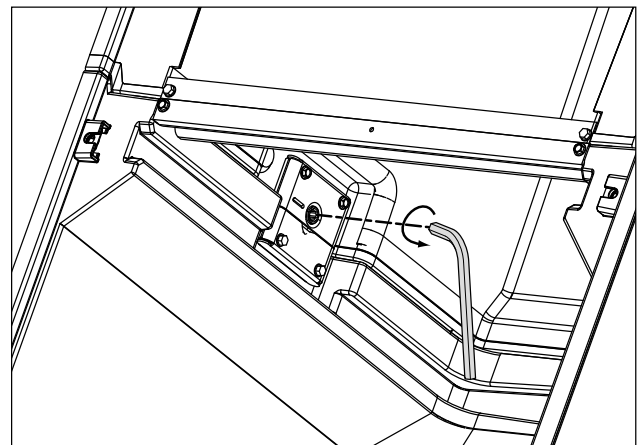



8. Lift the Coil section up and away from the Blower section. Set aside.

**Note:** When separating the two cabinet pieces, make sure the gasket remains intact.

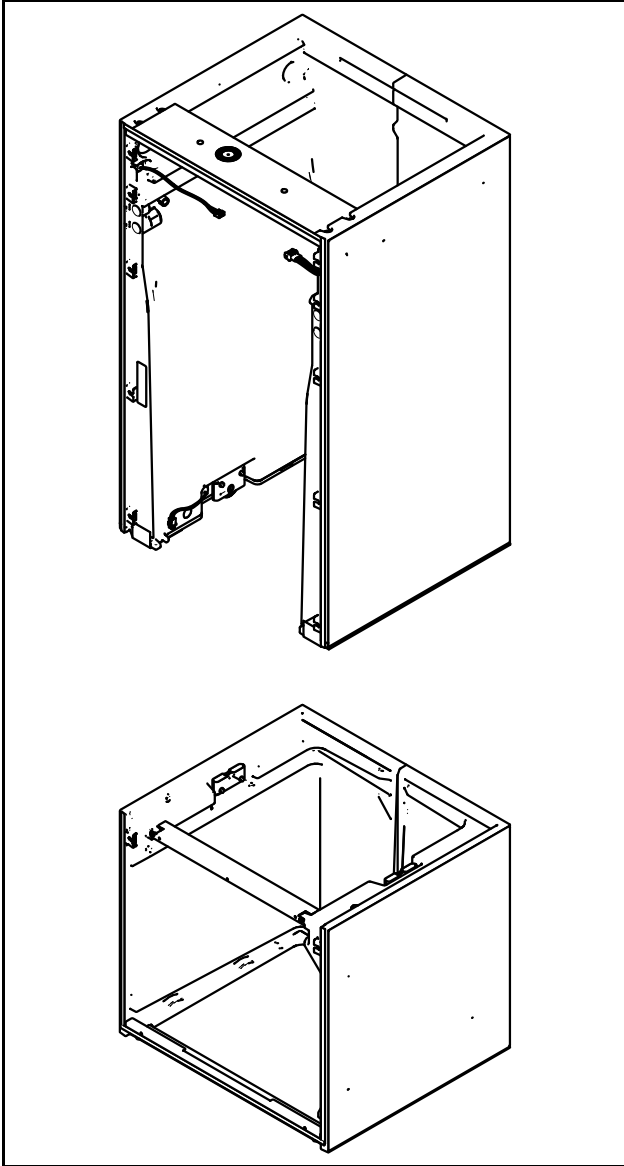

9. For extremely tight spaces where the cabinet needs to be rotated through a small opening, remove the top panel and all cross members. Use a manual driver to avoid stripping screw holes.

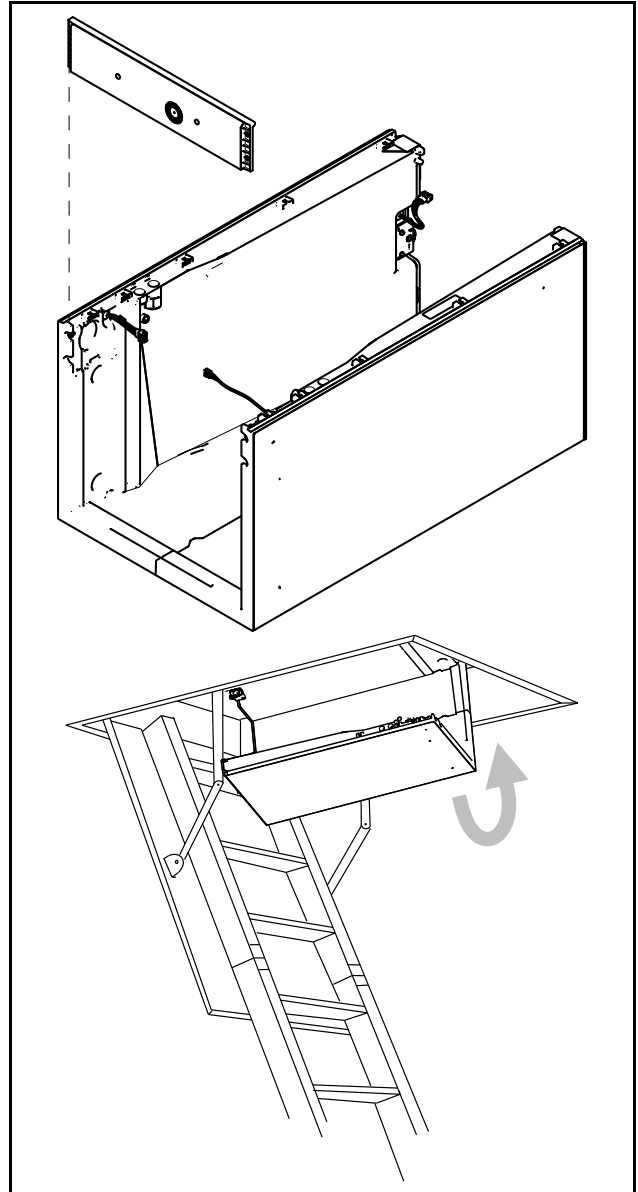

10. Continue preparation by following the proper carrying procedures shown in the next section.

# Placing Unit at Location

1. Carry the unit to the installation location
2. Reassembly by reversing the steps listed in Section 4 if disassembly was required. If cut, wire ties that held the sensor wiring must be replaced.

**Important:** Under no conditions should metal strapping be attached to the unit to be used as support mechanisms for carrying or suspension purposes.

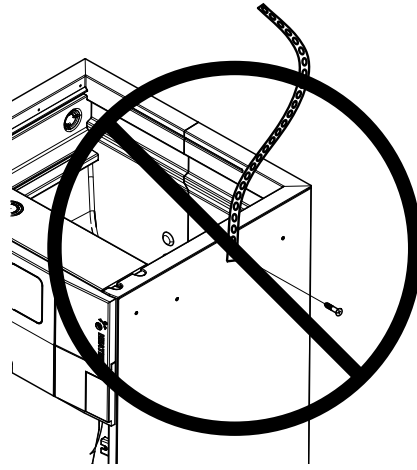

## Approved Carrying:

- Hold by the cross members within the cabinet or unit top plate and use as handles for lifting and carrying the coil and blower sections.

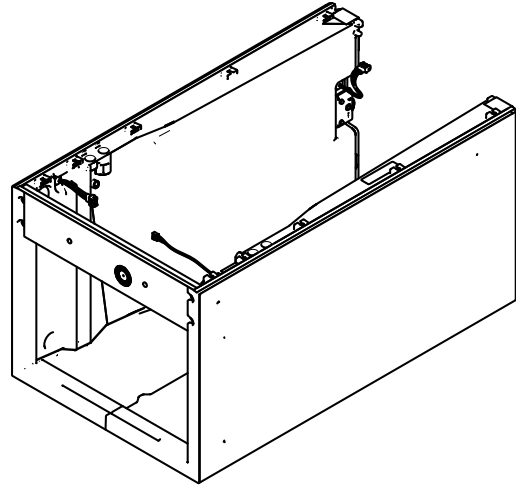

Cross Members

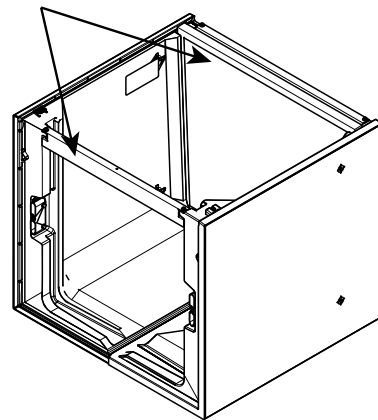

# Unit Location Considerations

**Table 3. Unit Dimensions and Weight**

MODEL NUMBER	H x W x D (inches)	Coil and Heater Compartment Height * (inches)	Unit Net Weight (pounds)
TAM9A0A24V21DB	49.9 x 17.5 x 21.8	28.1	116
TAM9A0B30V31DB	55.7 x 21.3 x 21.8	33.9	138
TAM9A0C36V31DB	56.9 x 23.5 x 21.8	35.1	146
TAM9A0C42V41DB	56.9 x 23.5 x 21.8	35.1	150
TAM9A0C48V41DB	61.7 x 23.5 x 21.8	39.9	162
TAM9A0C60V51DB	61.7 x 23.5 x 21.8	39.9	163

\* Blower compartment height is 21.8 inches.

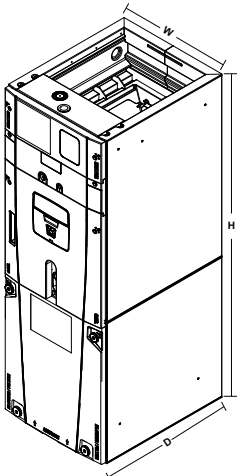

## Four-Way Conversion

To place the unit in the configuration your application requires (upflow, downflow, horizontal right, or horizontal left), simply turn the unit to that orientation. Remember to adjust the badge accordingly.

**Note:** The air handlers are shipped from the factory suitable for four-way application.

**Note:** Entry for low voltage connections is allowed on either side of cabinet.

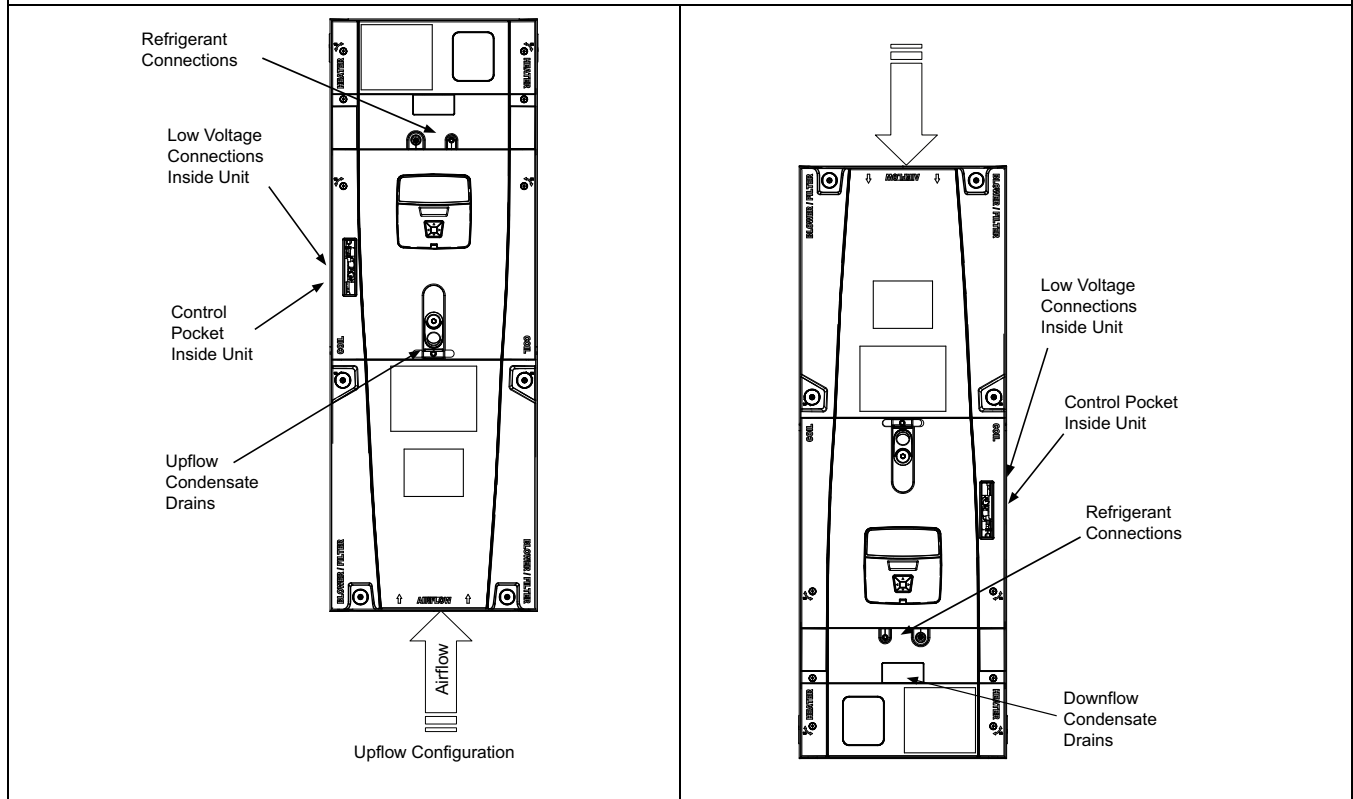

# Unit Location Considerations

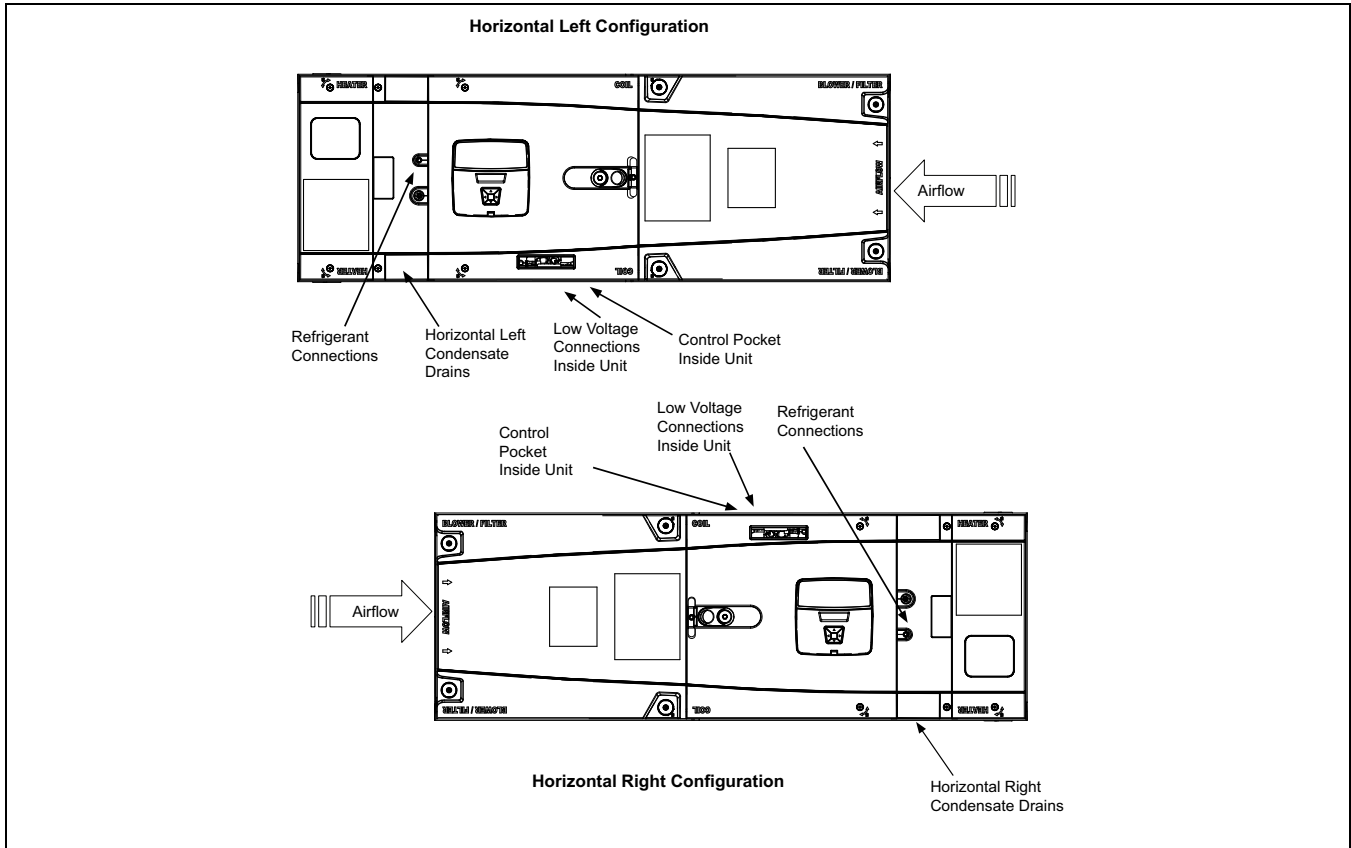

## Ducted and Non-Ducted Return Applications

Table 4. Non-Ducted Applications

<p><b>⚠ CAUTION</b> <b>HAZARDOUS VAPORS!</b> Failure to follow this Caution could result in property damage or personal injury. Hazardous vapors can be distributed throughout the conditioned space and equipment damage can result. Do not install an air handler with a non-ducted return in the same closet, alcove, or utility room as a fossil fuel device.</p>	<p>Supply Duct</p> <p>Plenum Accessory with Safety Guard</p> <p>Non-Ducted Return</p>
<p><b>Non-Ducted Return Installations:</b></p> <ul style="list-style-type: none"> <li>• Installation in a closet, an alcove, or a utility room without a return duct requires the use of a plenum accessory kit as it uses the area space as a return air plenum. Minimum clearances to combustible materials and service access must be observed (see outline drawing).</li> <li>• This area may also be used for other purposes, including an electric hot water heater, but in no case shall a fossil fuel device be installed and/or operated in the same closet, alcove, or utility room.</li> <li>• Review local codes to determine limitations if the unit is installed without a return air duct.</li> </ul>	

**Table 5. Ducted Return Installations.**

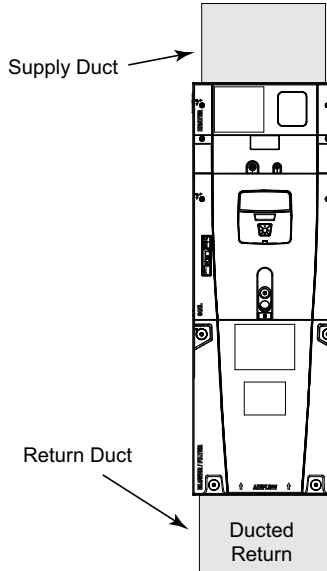
<p><b>Ducted Return Installations:</b></p> <ul style="list-style-type: none"> <li>Installation in an attic, garage, or crawl space with ducted supply and return air is appropriate. Minimum clearances to combustible materials and service access must be observed (see outline drawing).</li> </ul>	 <p>The diagram illustrates a vertical ducted return installation. At the top, a rectangular box is labeled 'Supply Duct'. Below it is a central air handler unit with various components like filters and coils. At the bottom, another rectangular box is labeled 'Ducted Return'. Arrows point from the text labels to their respective parts in the diagram.</p>
--	--

## Additional Unit Preparation Considerations

For proper installation the following items must be considered prior to moving the unit to its installation site:

- Pursuant to Florida Building Code 13-610.2A.2.1, this unit meets the criteria for a factory sealed air handler.
- If a side return is needed for your application, the side return **MUST** be prepared prior to moving the air handler to its installation location. See the Side Return Kit #BAYSRKIT100A Installer Guide for detailed instructions, if used.
- When the air handler is located adjacent to the living area, the system should be carefully designed with returns which minimize noise transmission through the return air grill. Although the air handler is designed with large blowers operating at moderate speeds, any blower moving a high volume of air will produce audible noise which could be objectionable when the unit is located very close to a living area. It is often advisable to route the return ducts under the floor through the attic. Such design permits the installation of air return remote from the living area (i.e. central hall).
- Study the unit's outline drawing and dimensions prior to selecting the installation site. Note in advance which electrical conduit entry points and condensate drain holes are to be used, so that proper clearance allowances can be made for installation and future maintenance.
- Installation of the air handler must be made prior to, or at the same time as, the installation of the

outdoor unit in order to allow access for refrigerant lines.

- Consider the overall space needed when external accessories are used, additional height and width requirements may exist.
- These units are not approved for outdoor installation.
- These units must be installed in the proper air flow direction.
- Any third-party heater accessories or hydronic coils must be downstream of the unit.

**Note:** No atomizing style humidifier is allowed in the return plenum with the use of this unit.

- Excessive bypass air may cause water blow-off, which will adversely affect system operation and air cleaner performance. To verify bypass airflow, follow the Bypass Humidifier Pre-Installation Checkout and Set-Up Procedures available through your local distributor. Ask for publication number 18-CH37D1-\* Steam and Flow-through Fan Power Duct-mounted Humidifiers. Follow the humidifier installation instructions. These should only be installed on the supply air side of the system.

**Note:** The air handlers have been evaluated in accordance with the Code of Federal Regulations, Chapter XX, Part 3280 or the equivalent. "SUITABLE FOR MOBILE HOME USE."

**Note:** This unit is certified to UL 1995. The interior cabinet wall meets the following:

- UL94-5VA Flame Class Listed
- UL723 Steiner Tunnel Listed for 25/50 Flame/Smoke
- UL746C Listed for Exposure to Ultraviolet Light, Water Exposure and Immersion

# Setting the Unit – Vertical Installation

**Table 6. Considerations**

Provide a minimum height of 14 inches for proper unrestricted airflow below the unit. Allow a minimum of 21 inches clearance in front of the air handler to permit maintenance and removal of filter.

- Position unit on suitable foundation. If a manufacturer approved accessory is not used, a frame strong enough to support the total weight of the unit, accessories, and duct work must be provided.
- Isolate unit from the foundation using a suitable isolating material.

**Note:** The following sound insulation kits are available to lessen objectionable sound.

- BAYINSKT175A for use with 17.5" cabinets
- BAYINSKT215A for use with 21.5" cabinets
- BAYINSKT235A for use with 23.5" cabinets

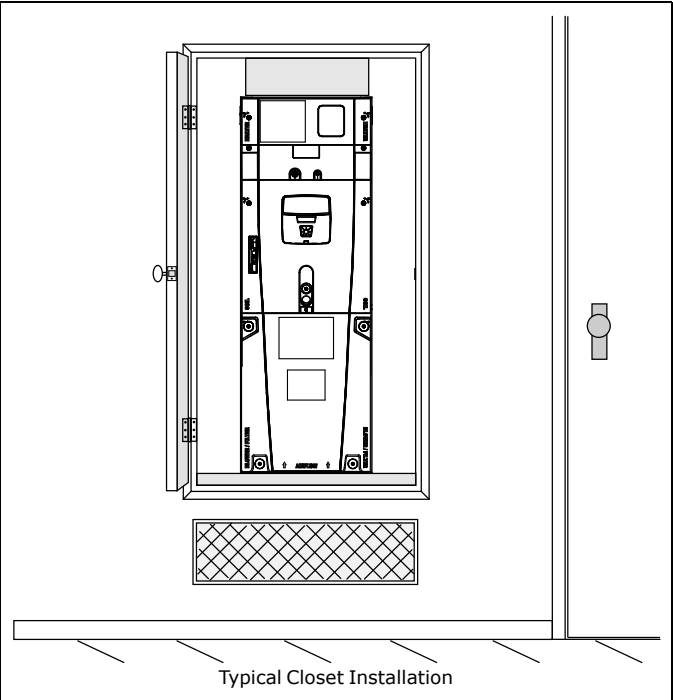

**Table 7. Upflow Installation**

**TASB Installation**

1. Install the TASB plenum stand with integrated sound baffle using the TASB instructions.

**Note:** Kit is used for open air applications.

- TASB175SB for use with 17.5" cabinets
- TASB215SB for use with 21.5" cabinets
- TASB235SB for use with 23.5" cabinets
- MITISRKIT1620 — Side return kit with 16" x 20" filter

Contact your distributor for more information.

**Note:** The following sound insulation kits are available to lessen objectionable sound.

- BAYINSKT175A for use with 17.5" cabinets
- BAYINSKT215A for use with 21.5" cabinets
- BAYINSKT235A for use with 23.5" cabinets

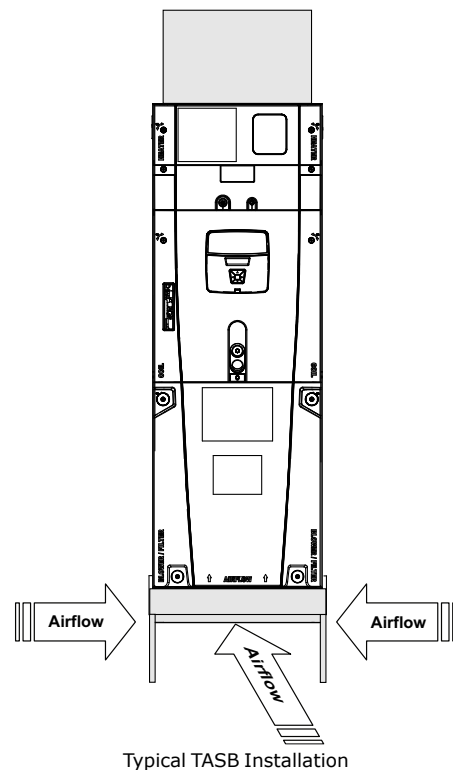

**Table 8. Plenum Installation**

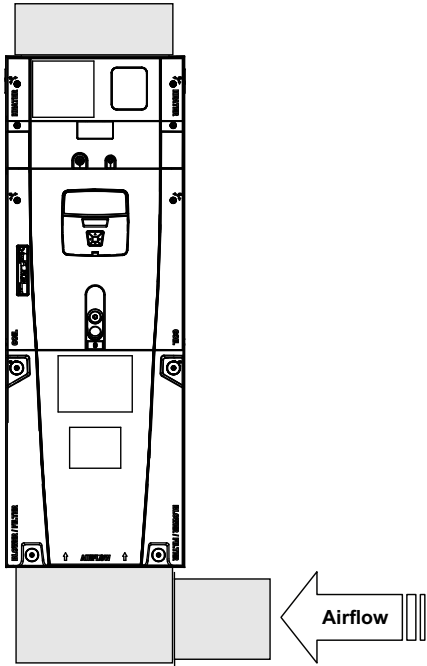
<p>2. Assemble the plenum using the plenum’s Installer Guide.</p> <p>On units with sheet metal returns: Return plenum must be flanged. Sheet metal drill point screws must be 1/2” in length or shorter.</p>	 <p style="text-align: center;">Typical Plenum Installation</p>
--	---

**Table 9. Downflow Installation**

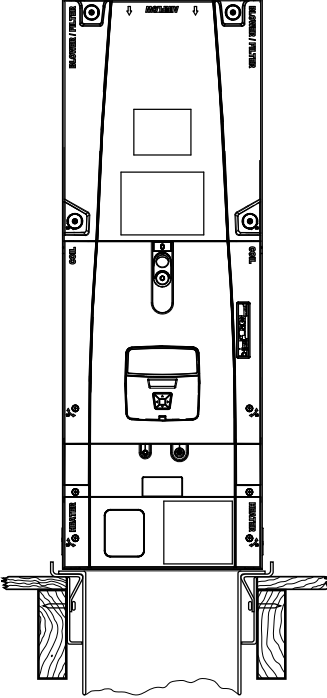
<ul style="list-style-type: none"> <li>• Downflow installation must comply with national, state, and local codes.</li> </ul> <ol style="list-style-type: none"> <li>3. Prepare the location site as appropriate for your application and per national, state, and local code requirements.</li> <li>4. Set the unit in position.</li> </ol>	 <p style="text-align: center;">Typical Downflow Installation</p>
---	---

# Setting the Unit – Horizontal Installations

**Table 10. Considerations**

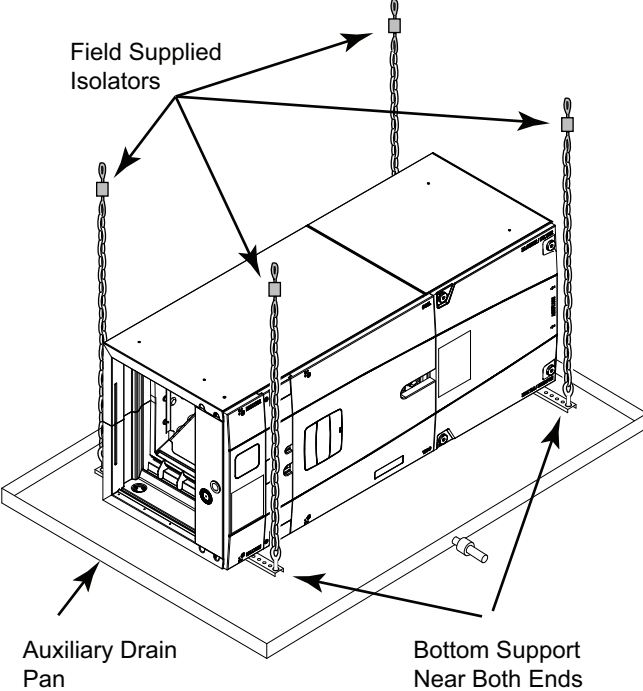
<p><b>Important:</b> Due to the unique design of this unit, which allows the electrical wiring to be routed within the insulation, do not screw, cut, or otherwise puncture the unit cabinet in any location other than the ones illustrated in this Installer Guide or in an approved accessory's Installer Guide.</p> <p><b>Important:</b> Make certain that the unit has been installed in a level position to ensure proper draining.</p> <p><b>Important:</b> Under no conditions should metal strapping be attached to the unit to be used as support mechanisms for carrying or suspension purposes.</p> <ol style="list-style-type: none"> <li>1. Support the unit from the bottom (near both ends). The service access must remain unobstructed.             <ol style="list-style-type: none"> <li>a. Approved bottom support methods are rail, u-channels (Unistrut®), or other load bearing materials.</li> <li>b. The unit must be isolated carefully to prevent sound transmission. Field supplied vibration isolators are recommended.</li> </ol> </li> </ol> <p><b>Important:</b> The unit can only be supported from the bottom unless using kit BAYHHKIT001A. Do not drill or screw supports into any area of the cabinet.</p> <p><b>Note:</b> Do not allow the unit to be used as strain relief.</p> <ol style="list-style-type: none"> <li>2. Install an auxiliary drain pan under the horizontal air handler to prevent possible damage to ceilings.             <ol style="list-style-type: none"> <li>a. Isolate the auxiliary drain pan from the unit and from the structure.</li> <li>b. Connect the auxiliary drain pan to a separate drain line and terminate according to local codes.</li> </ol> </li> </ol>	 <p><b>Note:</b> BAYHHKIT001A Hanging Bracket Kit may be ordered separately.</p> <p><b>Important:</b> The BAYHHKIT001A may not be used if the cabinet has been altered per Installer Guide 18-GJ58D1-5A-EN</p>
---	---



# Connecting the Duct work

**Table 11. Duct Connection Considerations**

**Important:** Due to the unique design of this unit, which allows the electrical wiring to be routed within the insulation, do not screw, cut, or otherwise puncture the unit cabinet in any location other than the ones illustrated in this Installer Guide or in an approved accessory's Installer Guide.

**Important:** Under no conditions should metal strapping be attached to the unit to be used as support mechanisms for carrying or suspension purposes.

**Important:** On units with sheet metal returns: Return air plenum must be flanged. Sheet metal drill point screws must be 1/2" in length or shorter.

- The supply and return air ducts must be connected to the unit with non flammable duct connectors.
- See the Outline drawing for sizes of the duct connections.
- After the ducts are secured, seal around the supply and return ducts to prevent air leakage.
- Insulate all duct work that will be outside of conditioned spaces.
- Convertible Duct Flange Kits are available to connect the supply plenum or for mounting on the discharge opening to provide a "flush fit" for 1-1/2" duct board applications.
- If front or rear return is required, the air handler must be elevated — placed on a pedestal or plenum and duct must be connected to this pedestal or plenum.
- If side return is required, the Side Return Kit # BAYSRKIT100A accessory must be used. A remote filter will be required.
- To ensure maximum efficiency and system performance, the existing supply and return duct system static pressures must not exceed the total available static pressure of the air handler. Reference ACCA Manual D, Manual S and Manual RS along with the air handler Product Data and Service Facts for additional information.

**Note:** Side return is not approved without Side Return Kit # BAYSRKIT100. More than one Side Return Kit may be necessary depending on the application. Refer to the Installation Guide in BAYSRKIT100 for approved duct connections, sizing, number, transitions, and accessory application.

**Note:** Duct work must be supported as appropriate. See National and local codes for guidelines. Do not depend on the unit to support duct work.

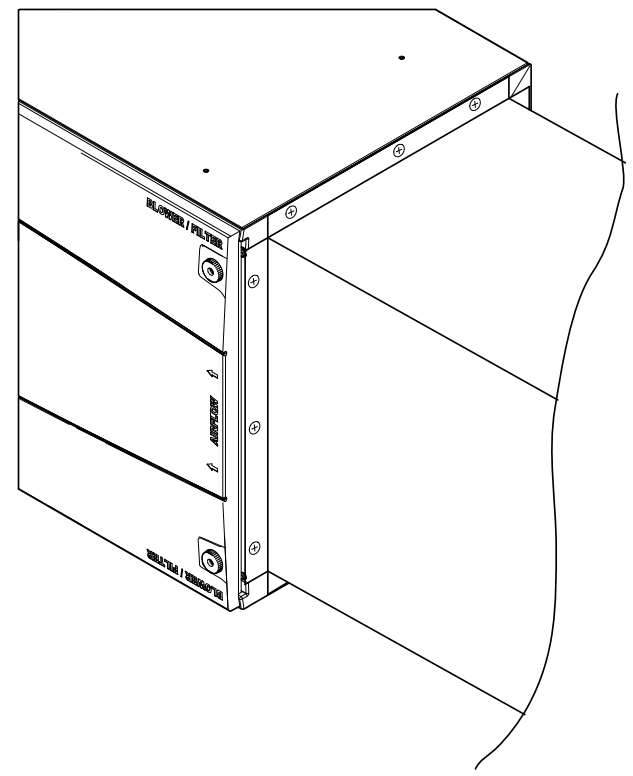
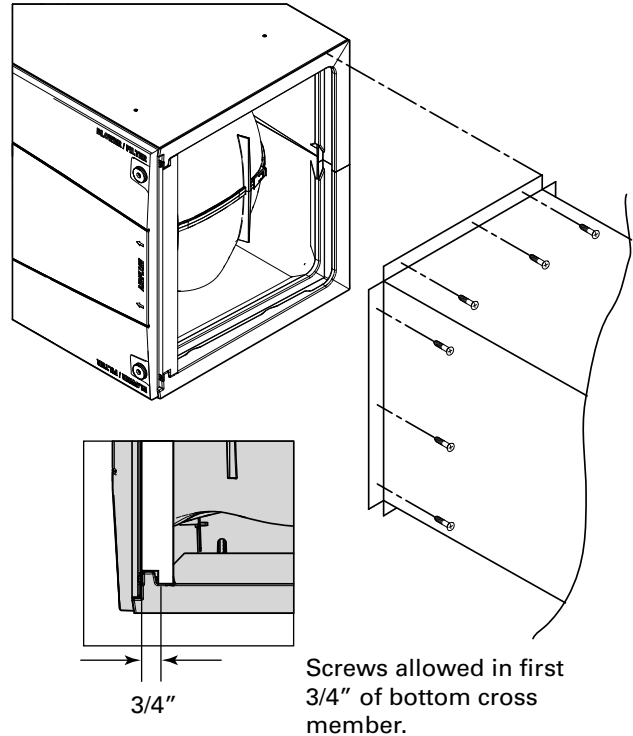

# Refrigerant Line

**Table 12. Refrigerant Line Connection Sizes**

Model	Vapor Line Connection	Liquid Line Connection
TAM9A0A24V21DB	3/4	3/8
TAM9A0B30V31DB	3/4	3/8
TAM9A0C36V31DB	7/8	3/8
TAM9A0C42V41DB	7/8	3/8
TAM9A0C48V41DB	7/8	3/8
TAM9A0C60V51DB	7/8	3/8

**Notes:**

1. This table indicates the tubing connection diameters at the indoor coil. A field supplied reducing coupling may be required.
2. All AHRI listed systems are tested with 25 feet of refrigeration tubing; the rated tubing diameters are located in the electronic performance data system.
3. If the refrigeration lines exceed 60 feet in linear length and/or if alternate size refrigeration tubing is present at the job, please consult SS-APG006-EN or 32-3312\*\* (latest version)

## Refrigerant System Layout

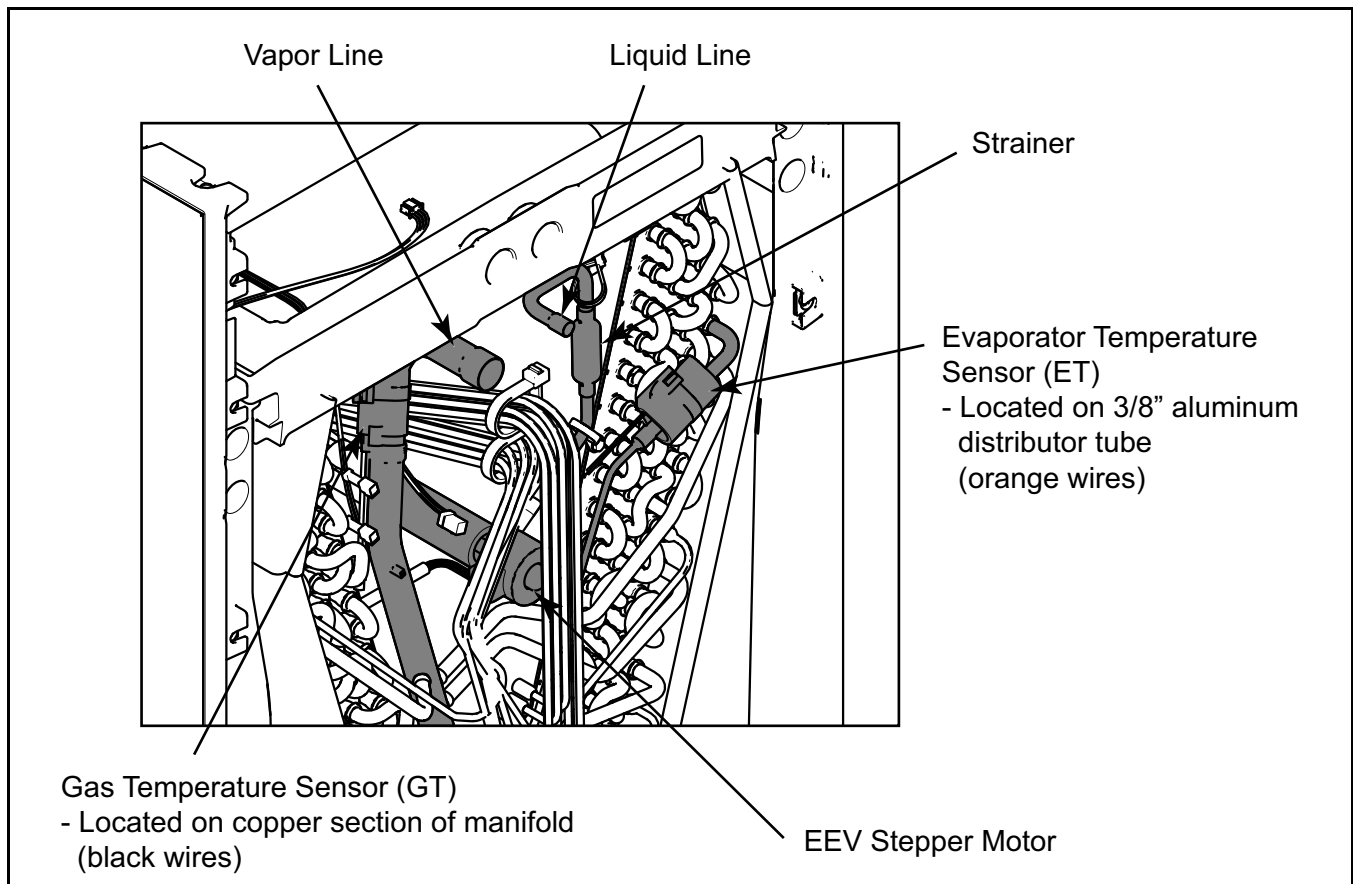

# Refrigerant Line Brazing

## Braze the Refrigerant Lines

1. Remove Heater, Coil, and Line Set panels.

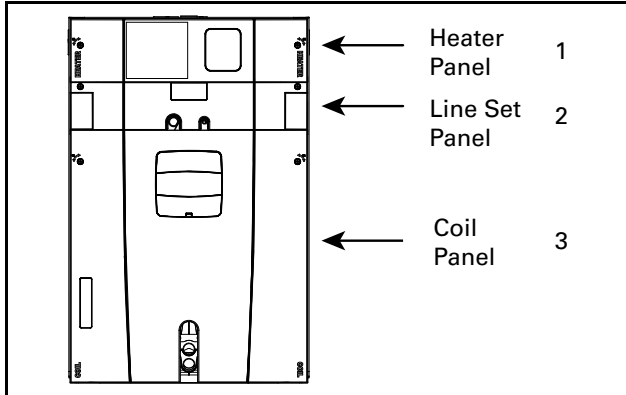

**Important:** Do NOT unseal coil refrigerant connection stubs until ready to make connections.

**Important:** Heat Sensitive Sensors. The Gas Temperature Sensor must be removed or a wet rag must be wrapped around the suction line between the Sensor and the braze joint to protect it from failure due to overheating.

2. Remove the sealing plug from the indoor coil suction line.
3. Remove the sealing plug from the indoor coil liquid line.

This coil is pressurized with 8–12 PSIG of dry air. Do not stand directly in front of the coil connections when removing sealing plugs.

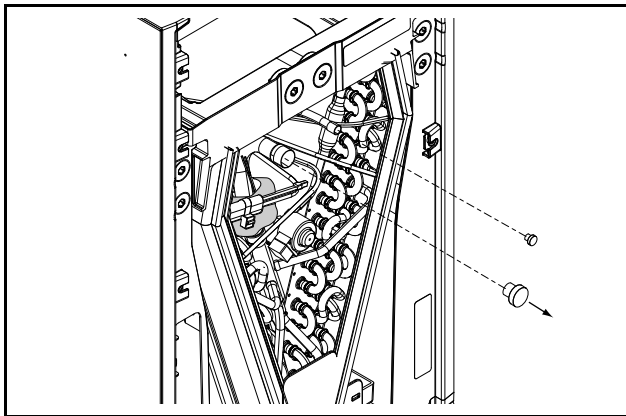

4. Connect, but do not braze field line set to indoor coil.
  - a. Allow a minimum of 1.5 inches of refrigerant line set before using an elbow coupling.

**Important:** Service access to the auxiliary heater must remain unobstructed.

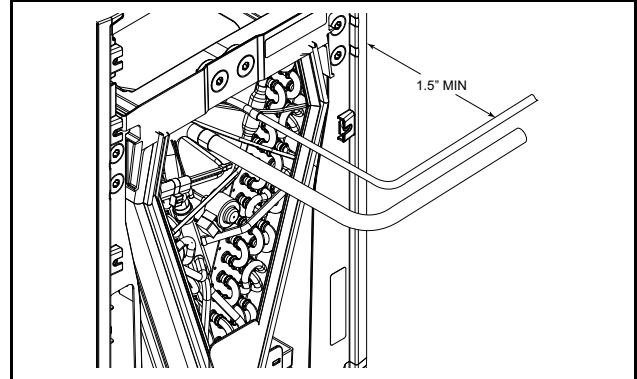

**Important:** Heat Sensitive Sensor. The temperature Sensor must be removed or a wet rag must be wrapped around the suction line between the Sensor and the braze joint to protect the Sensor from failure due to overheating.

5. Braze refrigerant line connections.
  - a. Pull back the insulation before brazing the suction line.
  - b. Wrap the Gas Temperature Sensor (GT) with a wet rag.
  - c. Braze the refrigerant line connections.

**Important:** Care must be taken during brazing to avoid damage to unit components and wiring.

**Note:** The suction line must be insulated prior to brazing the line set to the air handler stubs.

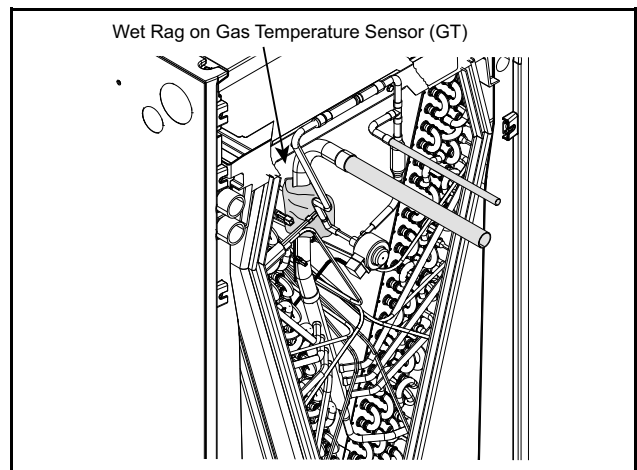

6. Pressurize the refrigerant lines and evaporator coil to 150 PSIG using dry nitrogen.

## Refrigerant Line Brazing

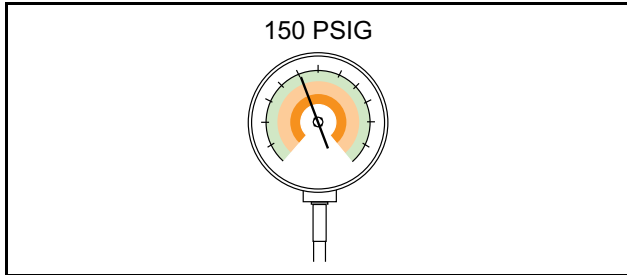

7. Check for leaks by using a soapy solution or bubbles at each brazed location.

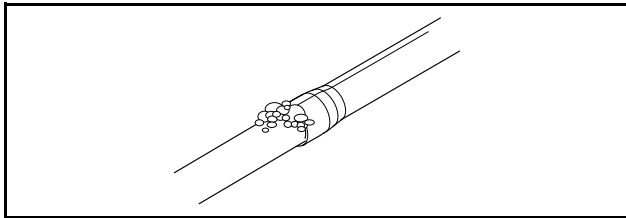

**Important:** Do not open the service valves until the refrigerant lines and indoor coil leak check and evacuation are complete.

8. Evacuate until the micron gauge reads no higher than 350 microns, then close off the valve to the vacuum pump.

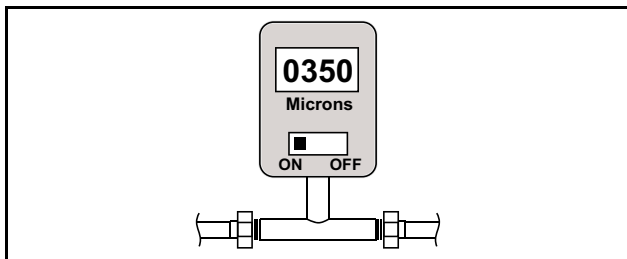

9. Observe the micron gauge. Evacuation is complete if the micron gauge does not rise above 500 microns in one (1) minute.
- Once evacuation is complete blank off the vacuum pump and micron gauge, and close the valves on the manifold gauge set.

**Note:** Charge system using Outdoor unit's Installer Guide or Service Facts.

**Note:** Use soapy water to wipe any refrigerant oil off the panels.



10. Replace the Line Set panel.

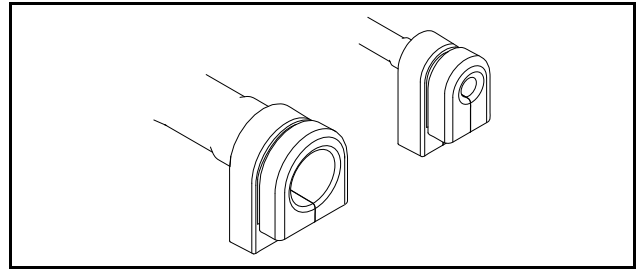

- Allow time for tubing to cool.
- Install grommets to line set piping in orientation shown.

**Note:** A slight amount of dish soap can be used to aid in the installation of the grommets. Remove any excess from the tubing and grommet after the grommet is installed.

- Slide the bottom of the Line Set panel down over the refrigerant lines and grommets. The grommets will seal the line openings.
- Tighten screws on the Line Set panel.

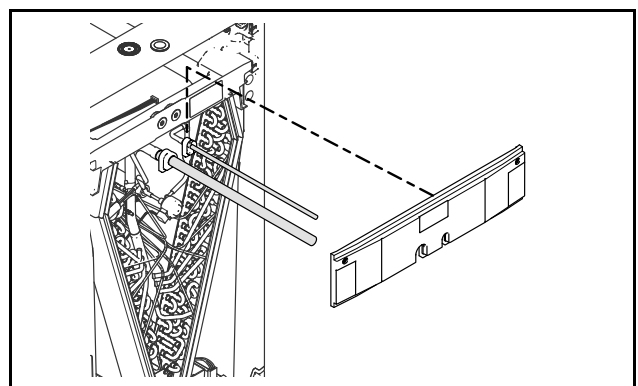
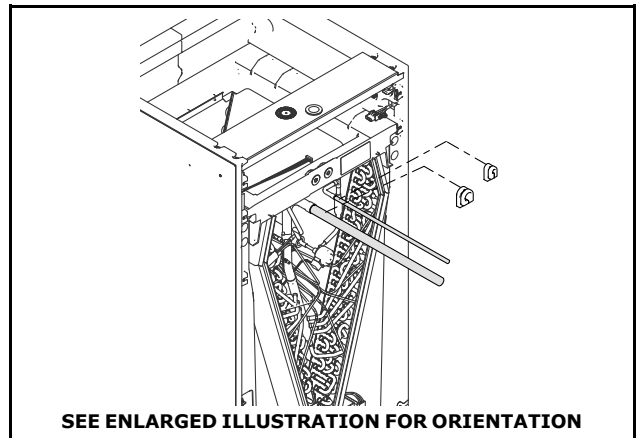

# Condensate Drain Piping

## Condensate Drain Piping Considerations

- Condensate drain plumbing must comply with national, state, and local codes.
- Route condensate drain lines away from air handler so they do not interfere with access panels.
- Slope the drain lines downward a minimum of 1/4" per foot, support per local codes.
- Do not use reducing fittings in the condensate drain lines.
- Do not connect the drain line to a closed drain system.
- Do not use a torch or flame near the plastic drain pan coupling.
- A P-trap is not required for proper drainage due to the positive pressure of the air handler; however, it is recommended to prevent efficiency loss of conditioned air.

## Connect Condensate Drain Piping

**Note:** Downflow and horizontal orientations require the Coil panel to be removed in order to make the drain connections.

**Note:** Make certain that the unit has been installed in a level position to allow for proper draining.

1. Select the drain connections that are oriented for your application.
2. Prepare the condensate drain connections.
  - a. From the factory, the unit comes with plugs in both upflow condensate drains and an additional plug in the documentation packet.
  - b. For upflow applications, remove upflow condensate plug(s) and connect condensate piping.
  - c. For all other applications, do not remove upflow condensate plugs. Remove the cover from the needed condensate drain connections and connect condensate piping.
  - d. If the secondary condensate opening is not used, plug the condensate opening with the fitting supplied in the documentation pack. Use scissors to cut the air seal in half and re-install over the unused opening.

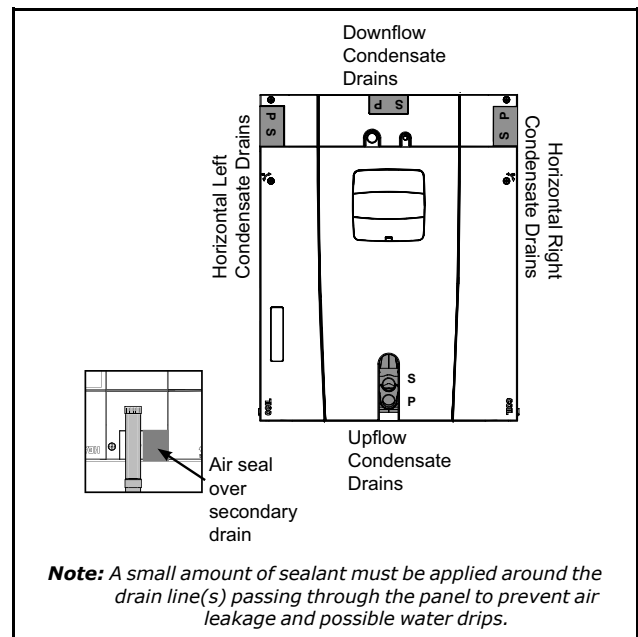

- **Dry fit and test clearance for coil panel removal before applying PVC/CPVC cement.**
  - **Use Teflon tape on the air handler drain line connections. Do not use pipe joint compound or PVC/CPVC cement on drain nipple.**
  - Hand tighten the drain pipe.
  - 3. For upflow installations, connect 3/4" PVC pipe to the threaded drain nipple with PVC/CPVC cement. 3" minimum clearance to the condensate piping is needed for coil panel removal. Thread the assembly into the primary drain connection (repeat for the secondary drain connection if used).
    - a. Remove panel and insert the 3/4" nipples.
    - b. Reinstall the panel.
    - c. Connect the condensate lines to the nipples.
- Important:** For Horizontal and Downflow installations, the following order must be observed:
- Note:** A small amount of sealant must be applied around the drain line(s) passing through the panel to prevent air leakage and possible water drips.

## Condensate Drain Piping

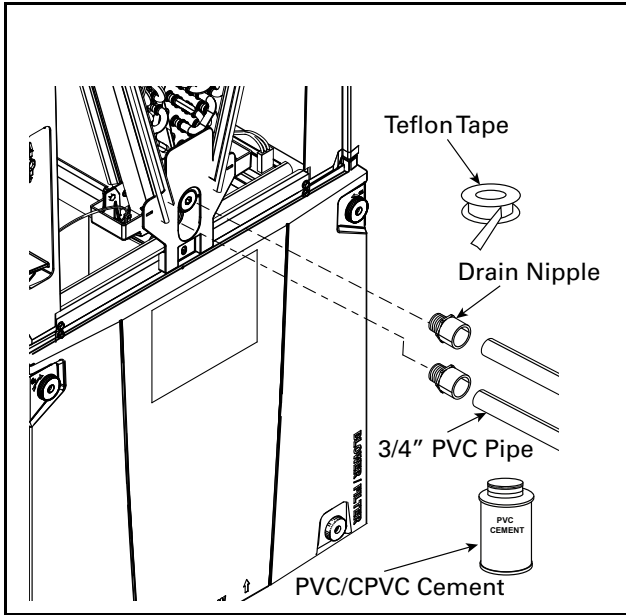

4. Install a clean-out tee in the primary drain line for future maintenance. It is recommended that you install a cap on the top of the tee.

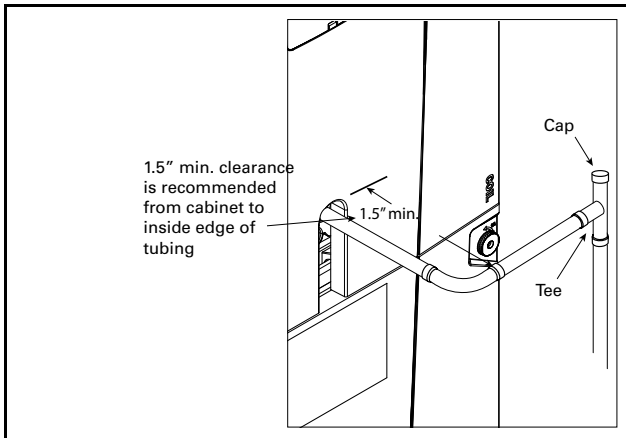

5. Insulate the primary drain line to prevent sweating where dew point temperatures may be met. (Optional depending on climate and application needs.)

Provide a means of drainage to prevent winter freeze-up of condensate line (Optional depending on climate and application needs).

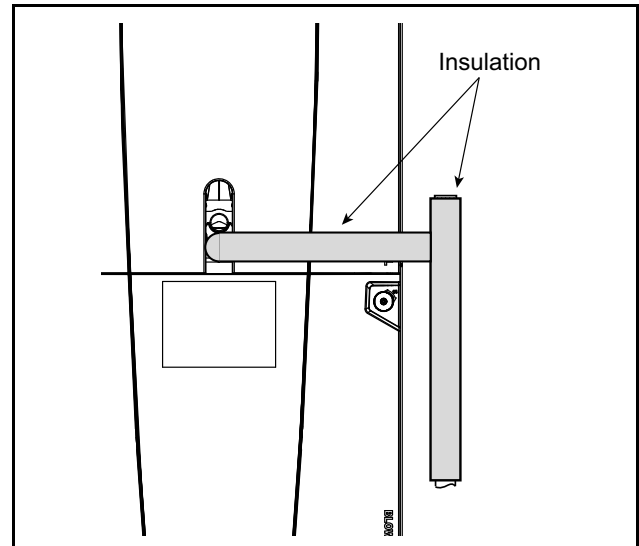

6. Support the condensate piping outside the unit per local codes for proper drainage and to prevent sagging.

Allow 1/4" of downward slope for each foot of pipe.

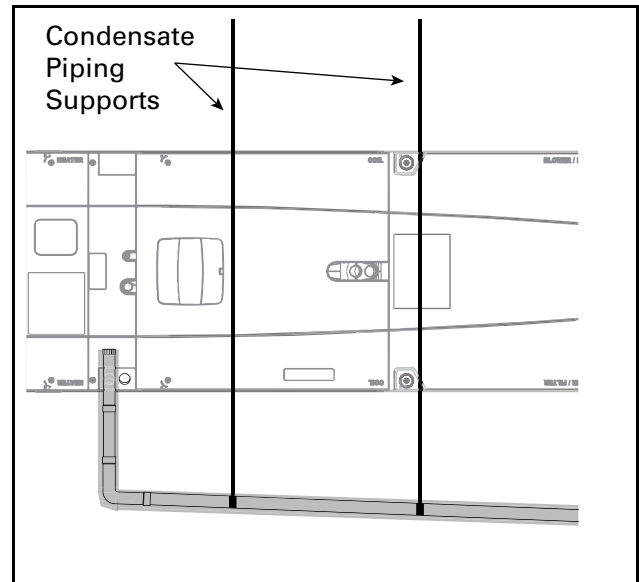

# Electrical – Low Voltage

**Table 13. Low Voltage Maximum Wire Length**

<p>The Low Voltage Maximum Wire Length table defines the size and combined total maximum length of the low voltage wiring from the outdoor unit, to the indoor unit, and to the thermostat.</p> <p><b>Note:</b> <i>The use of color coded low voltage wire is recommended to simplify connections between the outdoor unit, the control, and the indoor unit.</i></p>	Control Wire – Communicating	
	WIRE SIZE	MAX. WIRE LENGTH
	18 AWG	500 FT. Combined
	Control Wire – 24 Volt	
	WIRE SIZE	MAX. WIRE LENGTH
	18 AWG	100 FT. Combined

## Low Voltage Hook-up Instructions

**Note:** *Strain relief must be provided on the inside of the air handler cabinet for the low voltage wiring. Field supplied thermostat wired may be wire tied as a bundle to the existing strain relieved low voltage pigtail leads in the air handler unit.*

1. Route control wiring to unit. Remove the external sheathing of the wiring approximately 5".

**Note:** *Optional Low Voltage Conduit Entry Kit number BAYLVKIT100A is available.*

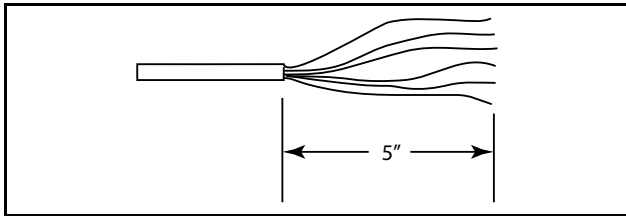

2. Remove Coil panel by turning the Phillips head door fasteners, rotating the door away from the cabinet, disconnecting the plug, and removing.

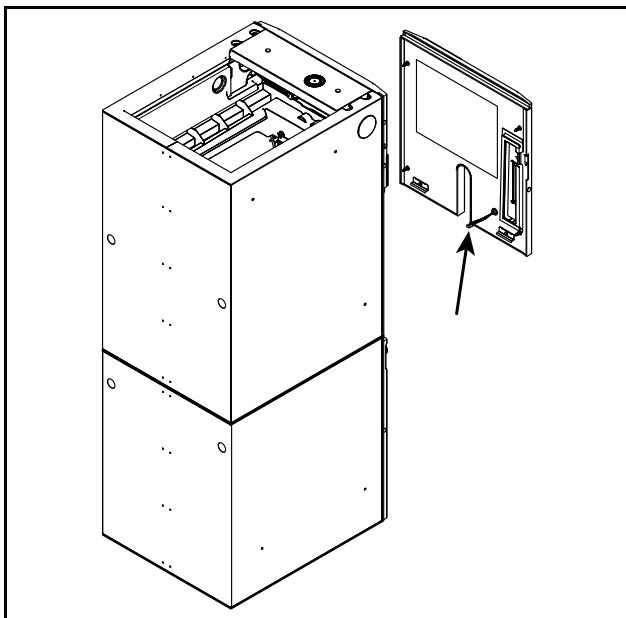

3. Remove the control board from the control pocket by sliding the control pocket mounting plate out until the first stop is reached.
4. Install the low voltage wire harness.

**Important:** *The low voltage wire harness is shipped in the supplied document pack.*

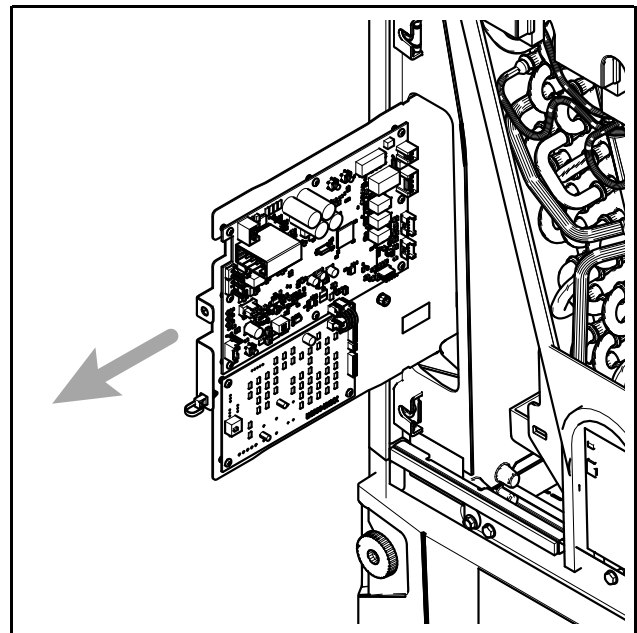

## For Horizontal Right Installations Only

5. Remove the control board completely from the control pocket. Rotate the control board 180 degrees. Place the control board 2–3 inches back into the control pocket.
6. Make connections per hookup diagrams.

**Important:** *After wires have been connected or service performed, the control board MUST be rotated back to the original orientation before inserting into cabinet control pocket.*

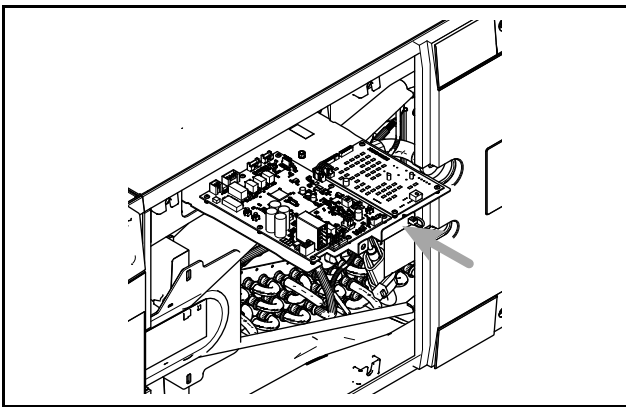
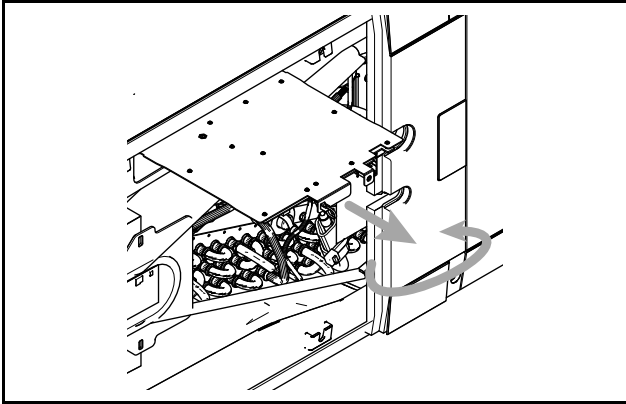

**Communicating Controls Wiring Diagram**

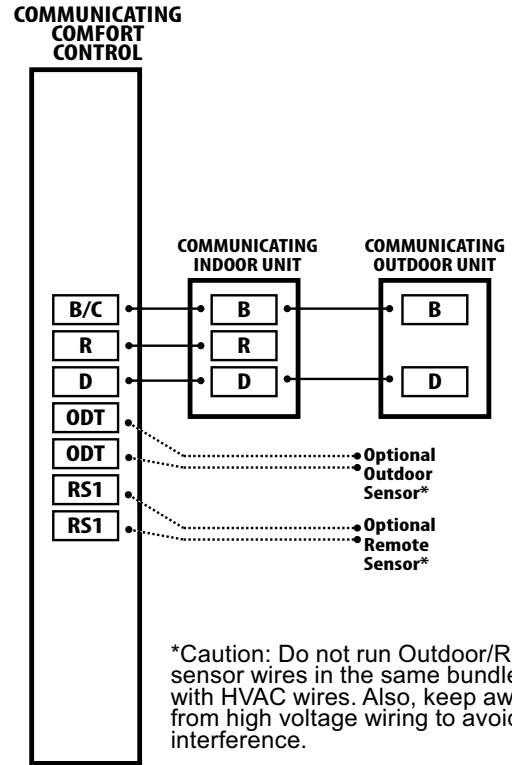

**1 OR 2 STAGE COOLING WITH TAM9/TAMG VARIABLE SPEED AIR HANDLER**

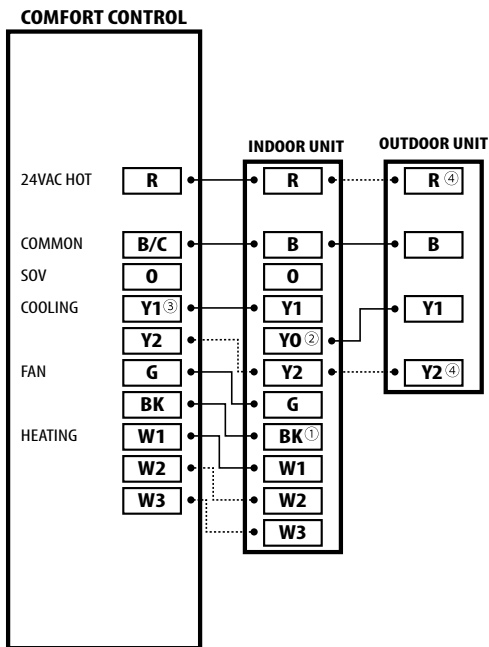

**NOTES:**

1. Cut the BK jumper on the AFC when using the BK functionality from the thermostat.
2. Y1 and YO connections must be made as shown for freeze protection and internally mounted condensate overflow circuits to function properly.
3. 3rd party condensate switches should break the Y1 circuit between the thermostat and AFC.
4. Y2 connections at outdoor unit are required only for two stage units.



### 1 OR 2 STAGE HEAT PUMP WITH TAM9/TAMG VARIABLE SPEED AIR HANDLER

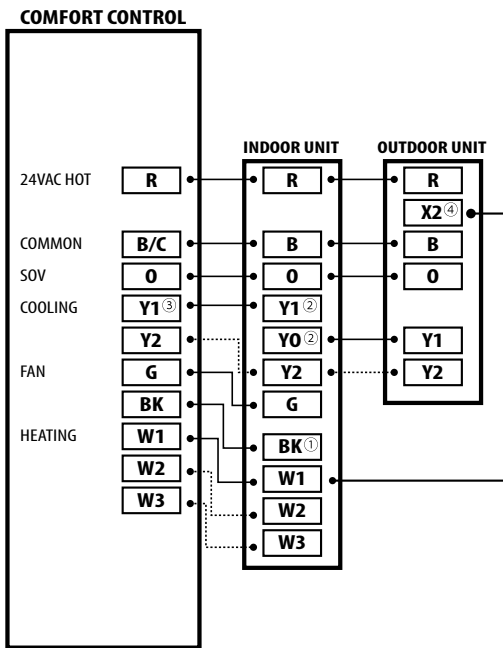

**NOTES:**

1. Cut the BK jumper on the AFC when using the BK functionality from the thermostat.
2. Y1 and YO connections must be made as shown for freeze protection and internally mounted condensate overflow circuits to function properly.
3. 3rd party condensate switches should break the Y1 circuit between the thermostat and AFC.
4. Connection to X2 is not required when using the 402, 624, 824, or relay panel controls.

7. Secure the sheathed wiring to the control pocket mounting plate using the factory supplied wire ties attached to the tabs as shown.

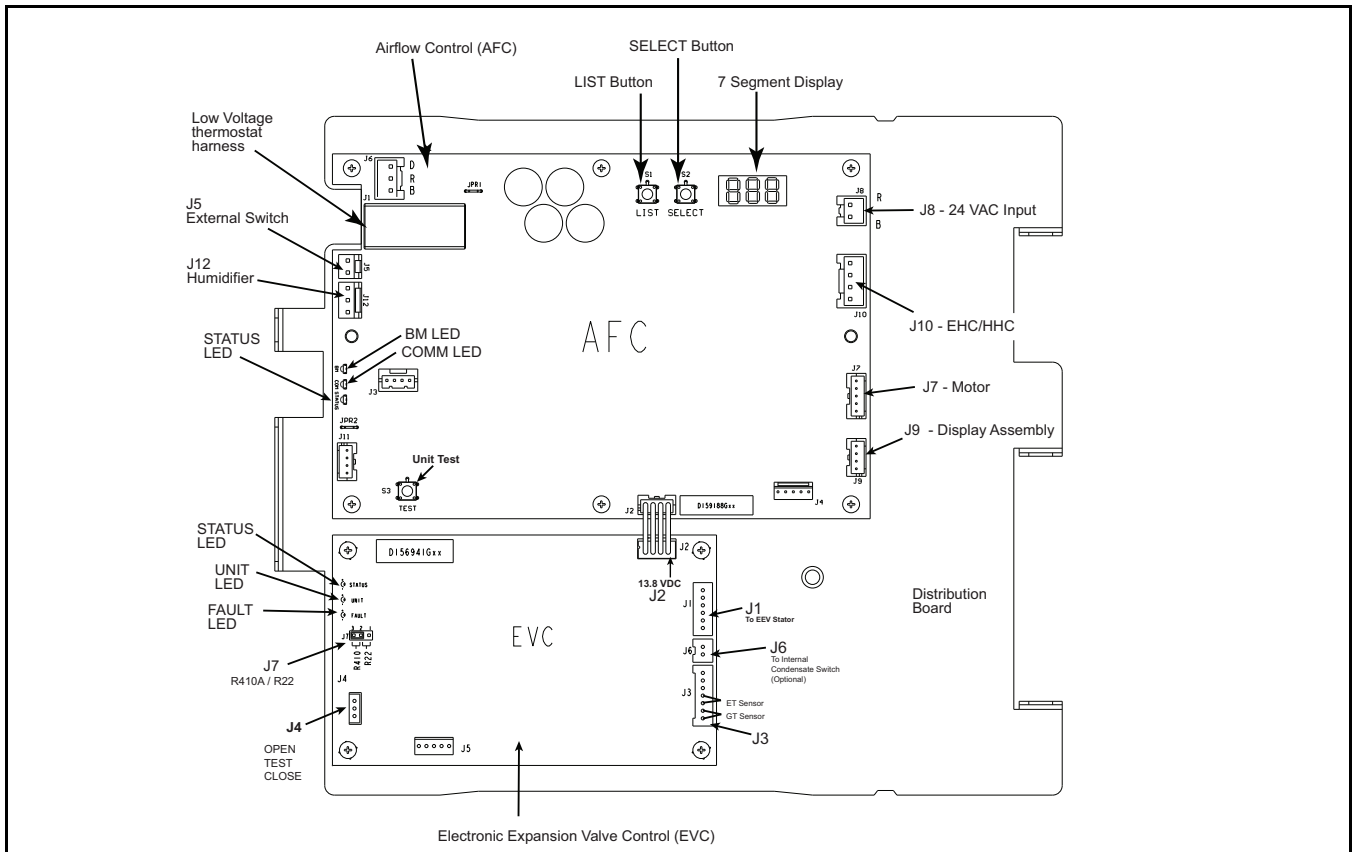

## Electrical — Low Voltage

### 8. Set Jumper and Dip Switches

- Set the system refrigerant to either R410A or R-22 using the Refrigerant Jumper located on the Expansion Valve Control board (EVC) in the Control Pocket.
- Factory default is R410A.

**Note:** The power must be shut off and then re-applied in order for the EVC to recognize the change.

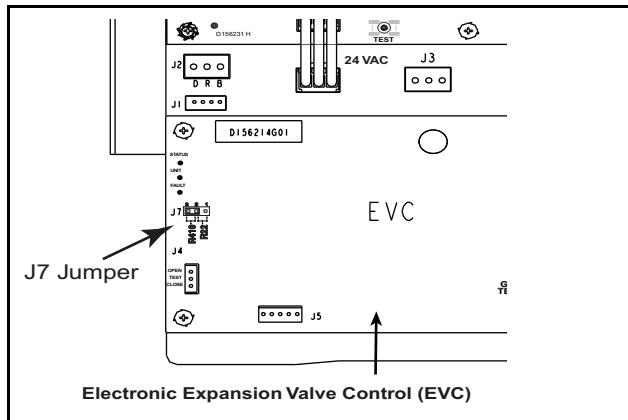

### Humidifier and External Switch

When connecting a humidifier or an external switch to the air handler, locate the harness(es) in the doc pack. The plug on the harness will plug into the AFC control board.

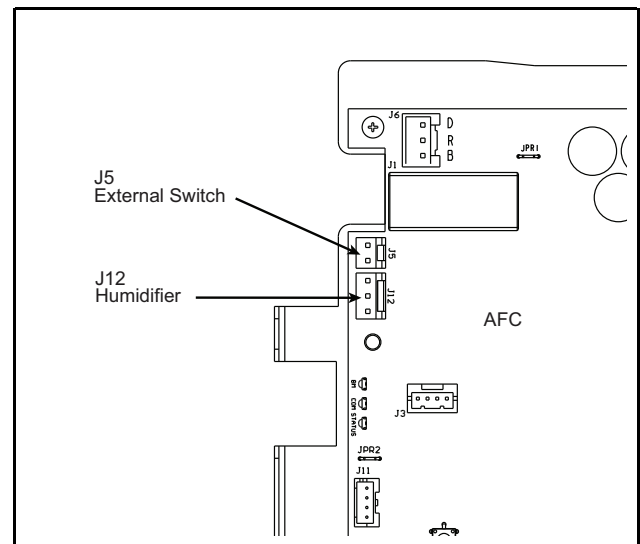
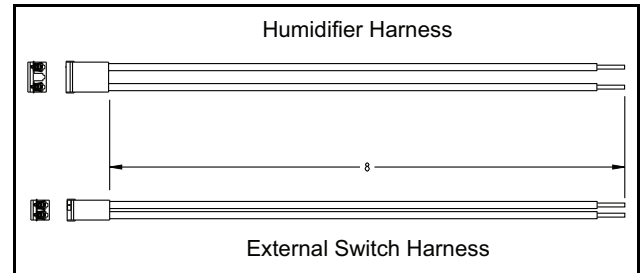

# Control Panel Reinstallation

- 1. Slide control plate assembly into the control pocket until fully seated. The control plate should be flush with the outer edge of the unit.

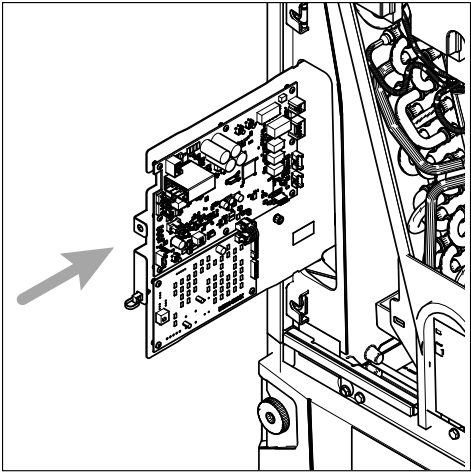

- 2. Replace coil panel making sure that the wires are located within the wire pass-through provided in the panel.

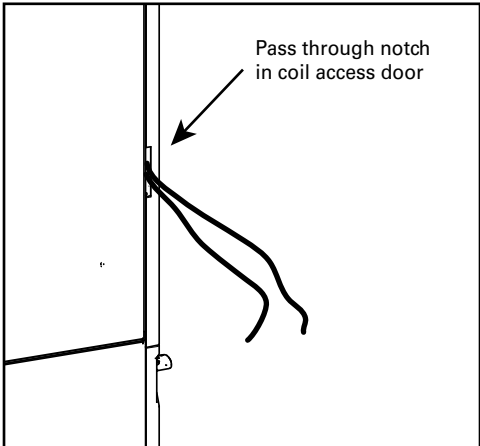
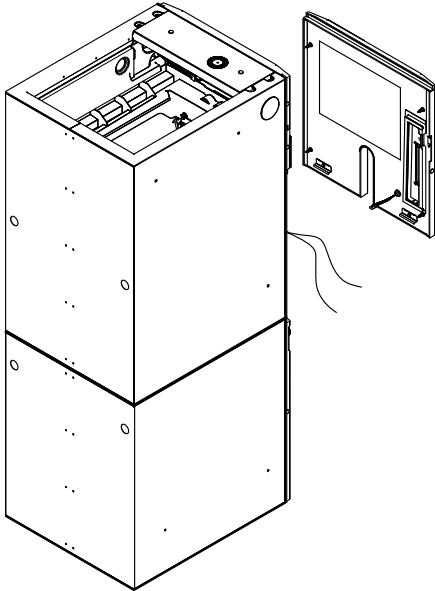

# Electrical – High Voltage

## High Voltage Power Supply

The high voltage power supply must match the equipment nameplate.

Power wiring, including ground wiring must comply with national, state, and local codes.

Field wiring diagrams for supplementary electric heaters are shipped with the heaters.

### **⚠ WARNING**

#### **LIVE ELECTRICAL COMPONENTS!**

Failure to follow this Warning could result in property damage, severe personal injury, or death.

Follow all electrical safety precautions when exposed to live electrical components. It may be necessary to work with live electrical components during installation, testing, servicing, and troubleshooting of this product.

## Make Electrical Connections

1. Route High Voltage wiring to unit.
2. Select a conduit entry point. Drill a hole for the desired conduit size up to 1-1/2" diameter. A locating target is identified on these units.
  - a. Select the entry point you will use to bring in your high voltage wiring.

**Note:** When drilling access through cabinet do not drill into any internal components. Remove internal components before drilling through cabinet, if possible. Damage to the air handler or heater could result.

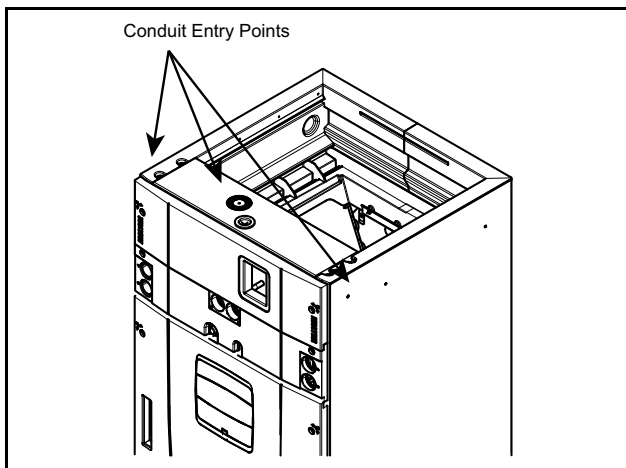

3. Route conduit (if used) to the entry point and connect.

- a. Use one hand to secure the conduit nut from inside of the heater compartment.
- b. Connect a field supplied 3/4" or 1-1/2" conduit to conduit nut.

**Note:** Reducing bushings may be required for your application.

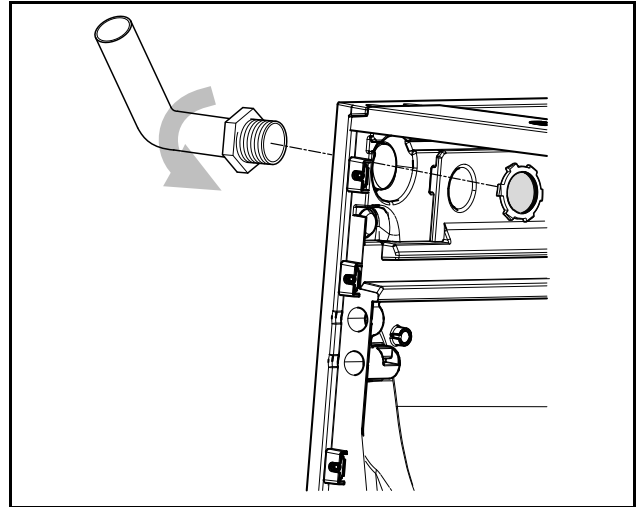

4. If an electric heater **IS NOT** being installed, remove the pigtail harness from the documentation pack and connect it to the plug on the inside of the Heater Compartment in the cabinet.

If an electric heater **IS** being installed, see the Installer's Guide shipped with the electric heater.

**Note:** The electrical heater size needs to be set in the Configuration Menu.

Connect L1, L2, and ground wiring to pigtail harness in Heater Compartment using wire nuts. The incoming ground wiring will mate up with the green wire shown in the illustration.

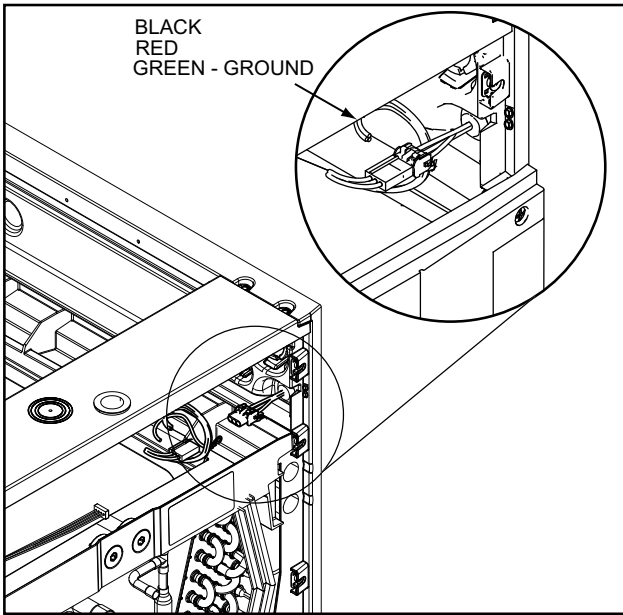

5. If the L1, L2, and ground wires enter the case from the left side, use a field supplied 1/2" – 5/8" maximum length screw and wire tie to hold the wires to the top center of the Heater Compartment.

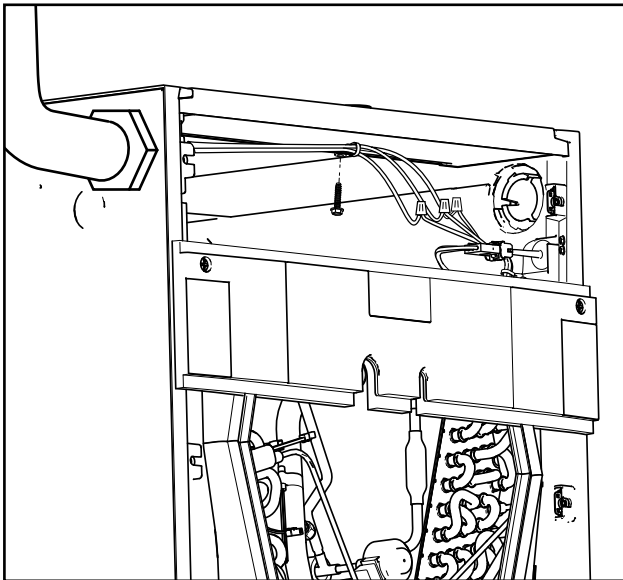

6. Reinstall all panels before starting the air handler

**Note:** After replacing all panels, loosen the Line Set Panel screws approximately 1/4 – 1/2 turn. This will improve the seal between the Heater Panel and Line Set Panel.

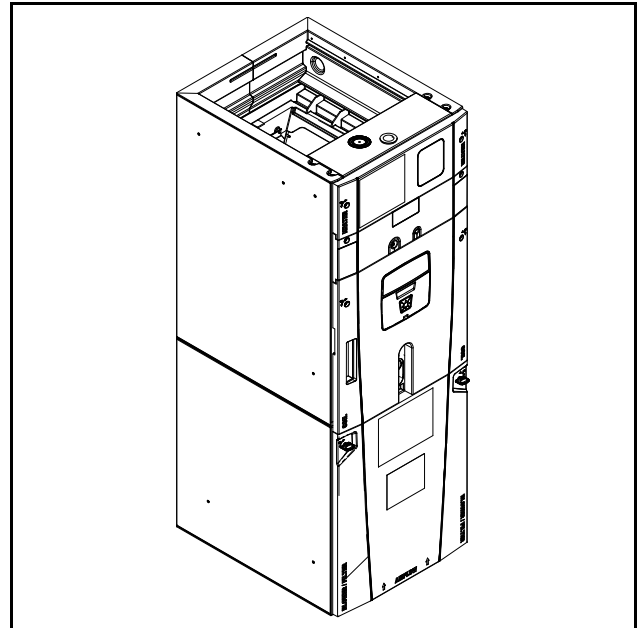

7. Remove screw and coil bracket from documentation packet.
8. Place the coil panel bracket into position and use screw to secure the coil panel bracket and seal plate to the support bar.

**Important:** The Coil Seal Plate and screw secure the coil in the center of the air handler. Failure to follow these steps can prevent the Coil Panel from being easily replaced on the unit.

**Important:** The Blower Panel may be removed if needed to help align the new screw with the seal plate and crossmember.

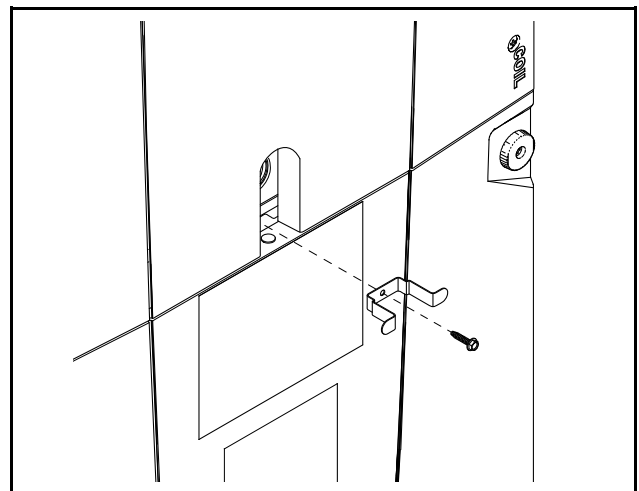

# Outline Drawing

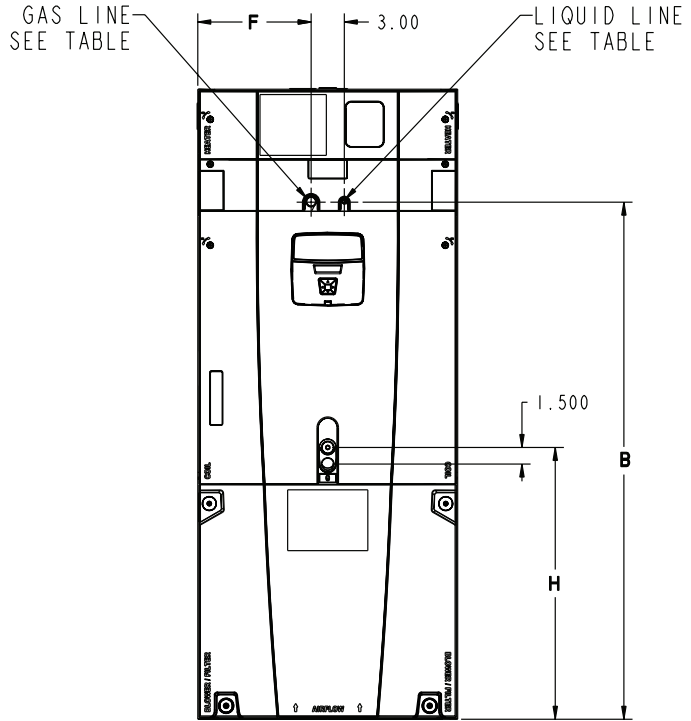
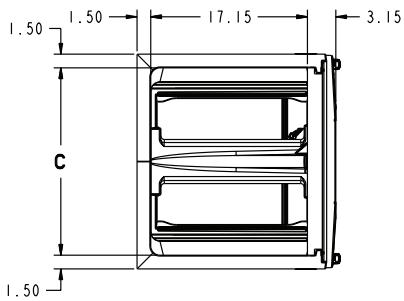
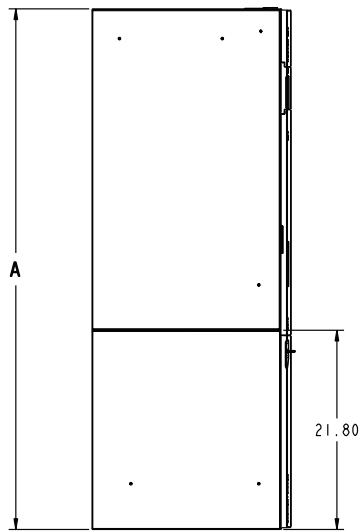
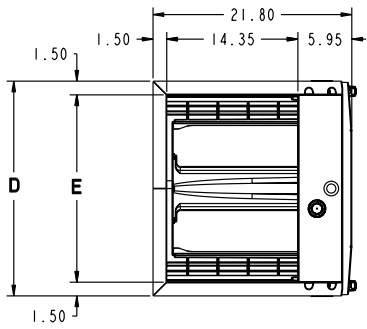

MINIMUM UNIT CLEARANCE TABLE	
	SERVICE CLEARANCE (RECOMMENDED)
SIDES	2"
FRONT	21"
BACK	0"
INLET DUCT	
OUTLET DUCT	

NOTE: THIS UNIT IS APPROVED FOR INSTALLATION CLEARANCES TO COMBUSTIBLE MATERIAL AS STATED ON THE UNIT RATING NAMEPLATE

Model Number	A	B	C	D	E	F	H	FLOW CONTROL	GAS LINE BRAZE	LIQ LINE BRAZE
TAM9A0A24V21DB	49.9	39.6	14.5	17.5	14.5	7.3	24.4	EEV	3/4	3/8
TAM9A0B30V31DB	55.7	45.5	18.4	21.3	18.4	9.2	24.8	EEV	3/4	3/8
TAM9A0C36V31DB	56.9	46.7	20.5	23.5	20.5	10.3	24.2	EEV	7/8	3/8
TAM9A0C42V41DB	56.9	46.7	20.5	23.5	20.5	10.3	24.5	EEV	7/8	3/8
TAM9A0C48V41DB	61.7	51.5	20.5	23.5	20.5	10.3	24.9	EEV	7/8	3/8
TAM9A0C60V51DB	61.7	51.5	20.5	23.5	20.5	10.3	24.9	EEV	7/8	3/8

# Display Assembly / Human Interface

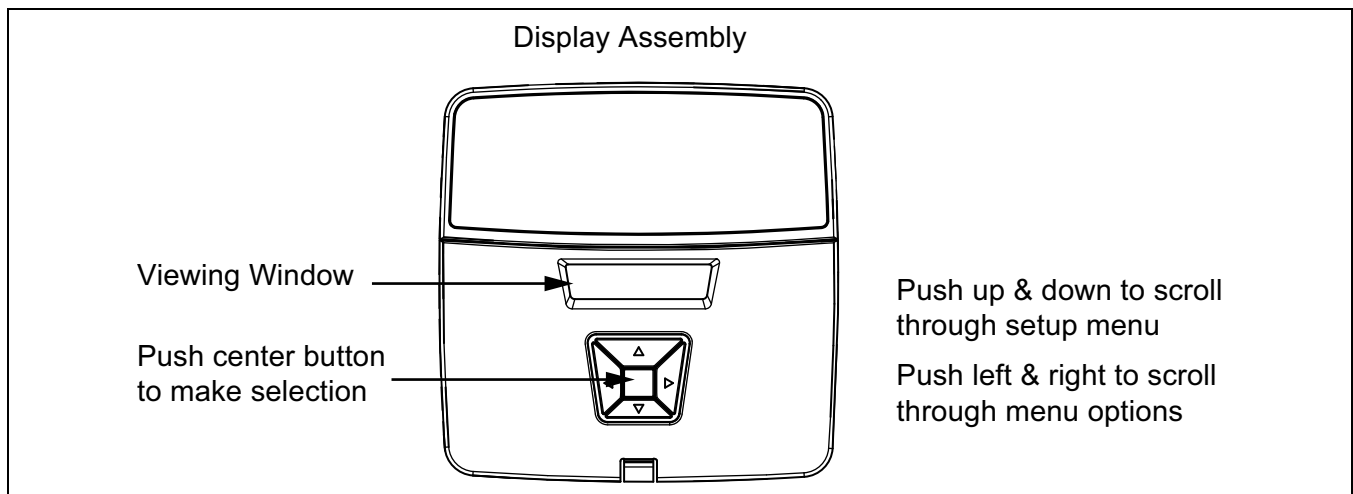

## Display Assembly General Notes

### • Home Screen

- The System Status is shown continuously on the Home Screen. The System Status will alternate with fault information if there is an active fault. Low level faults do not appear on the Home Screen.

### • Technician Screens

- To Enter the technician menu section, press the Up/Down menu keys simultaneously for 10 seconds.

- To Exit the technician menu section, press the Up/Down menu keys simultaneously for 10 seconds.
- To move to the top of any menu tree, press the Left/Right menu keys simultaneously for 1-2 seconds. Press the Left/Right menu keys a second time for 1-2 seconds to return to the Home Screen.
- While in a technician menu, after 5 minutes of inactivity, the Home Screen will be displayed. This time can be increased to 20 minutes by pressing the Enter menu key for 2-3 seconds.

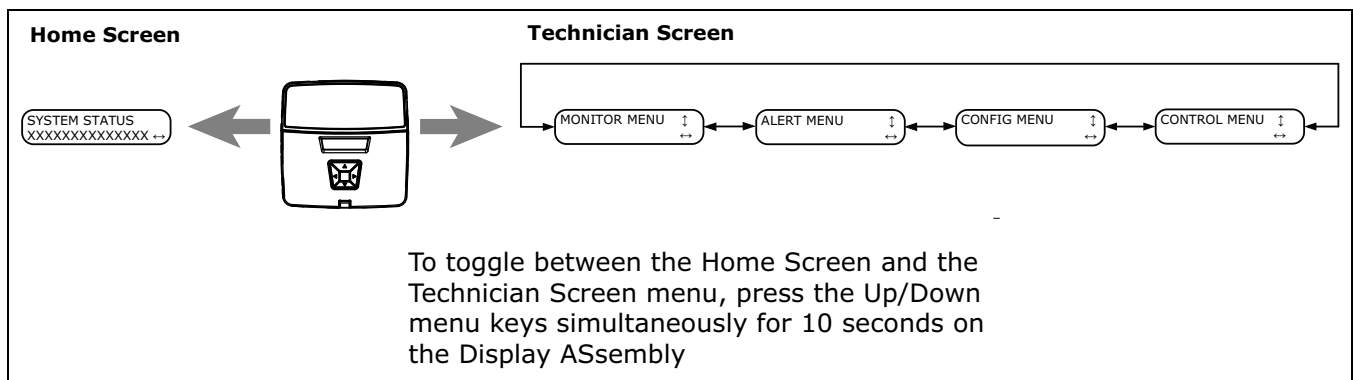

# TAM9 – Technician Menu and Configuration tree

Table 14. CDA Home Screen

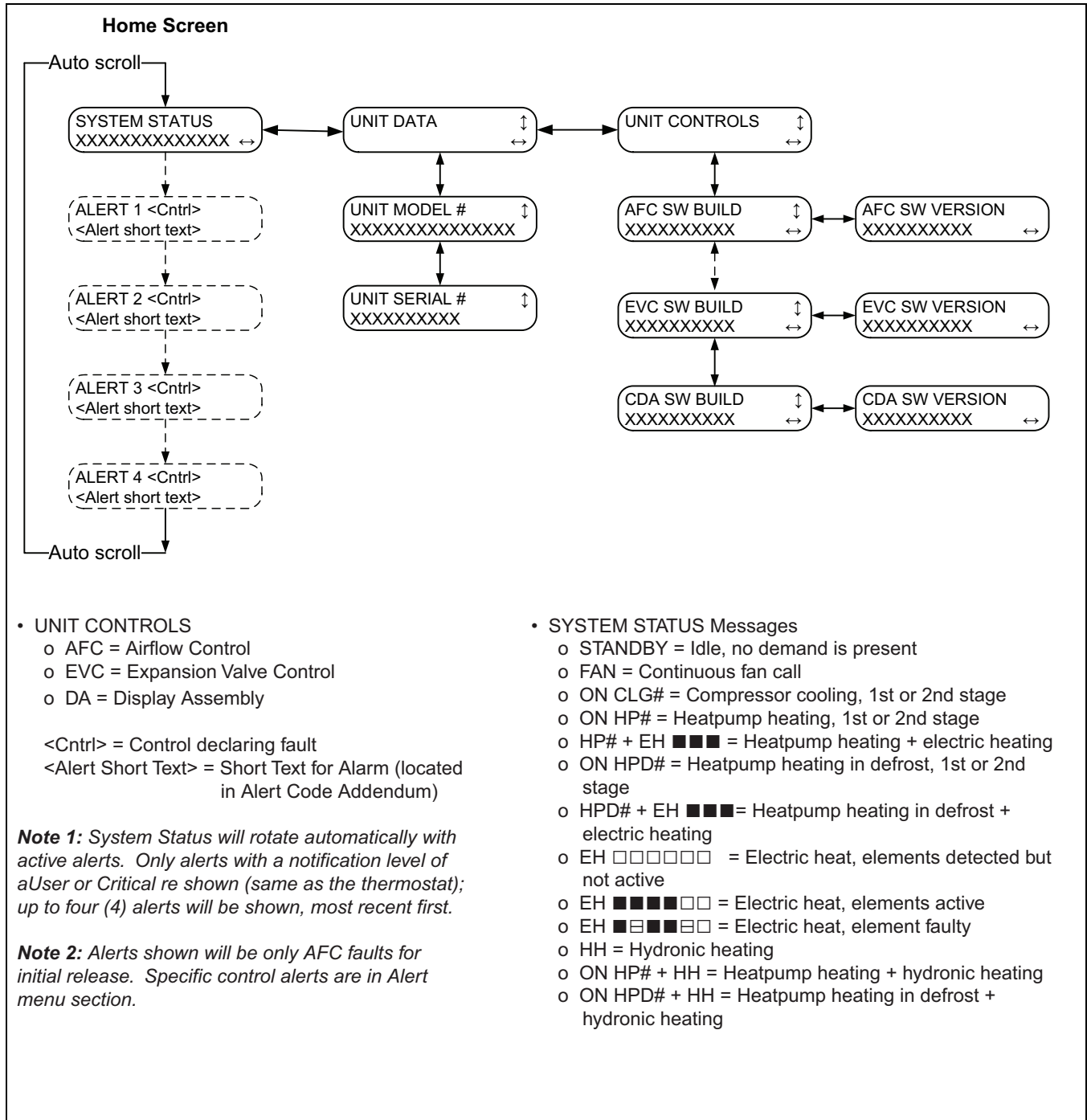



Table 15. CDA Monitor Menu

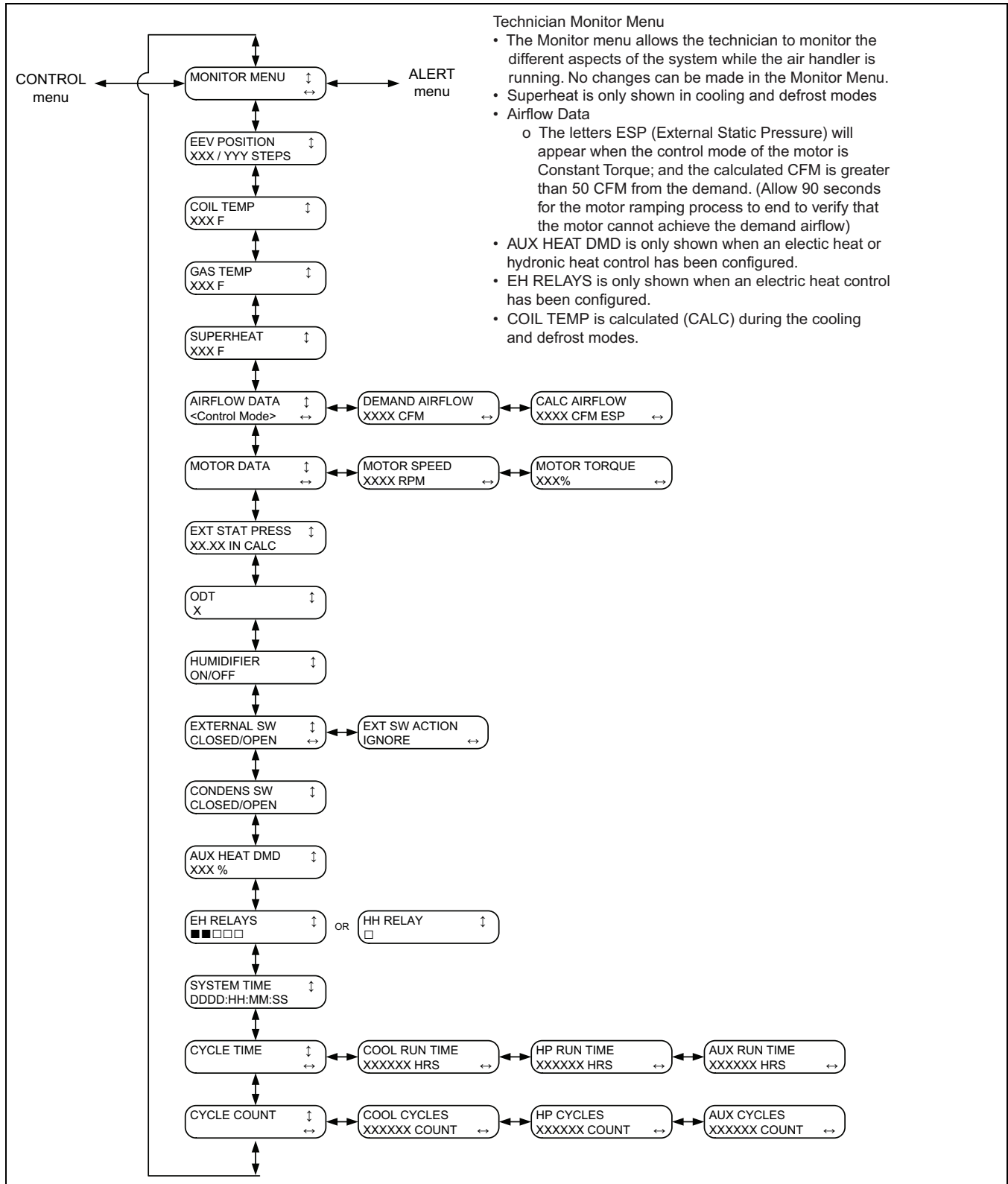
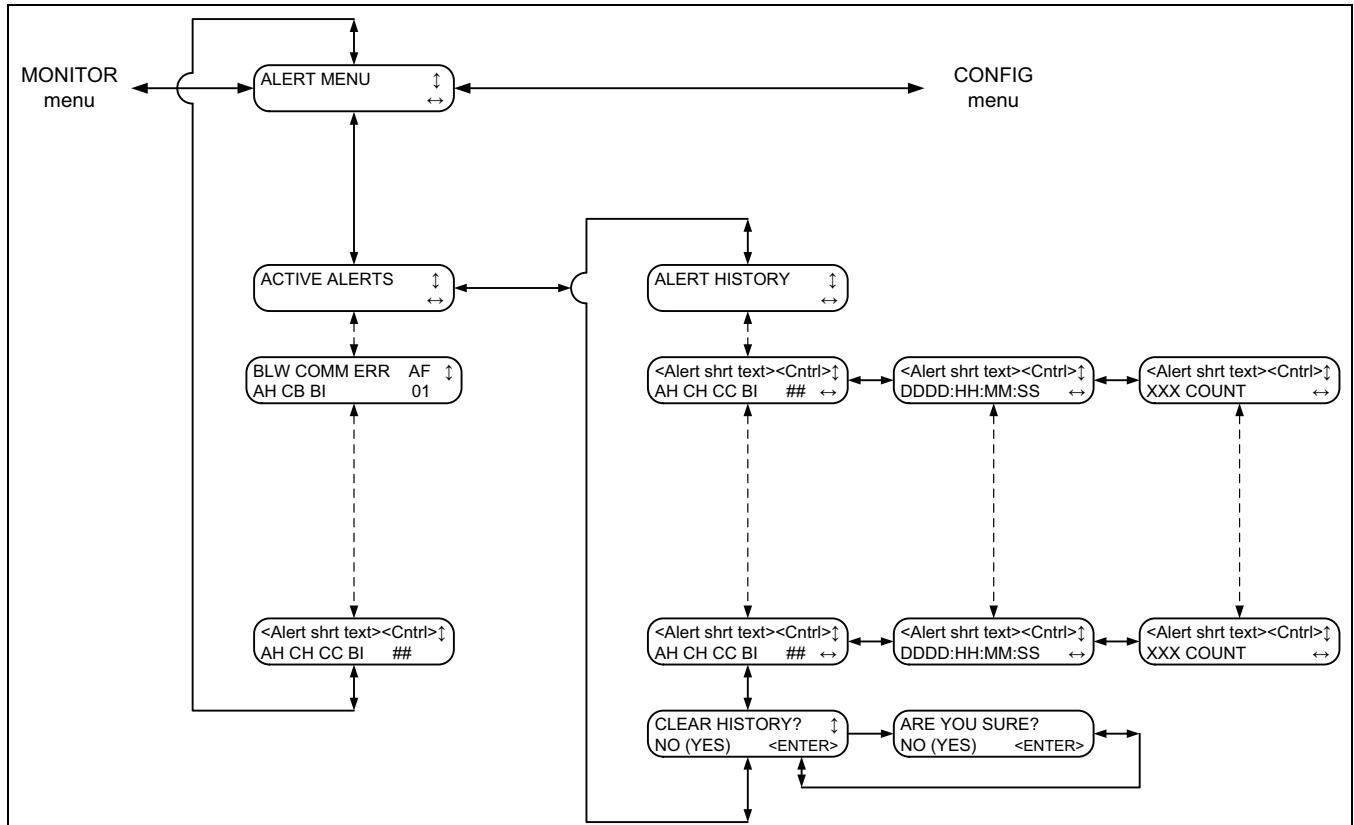
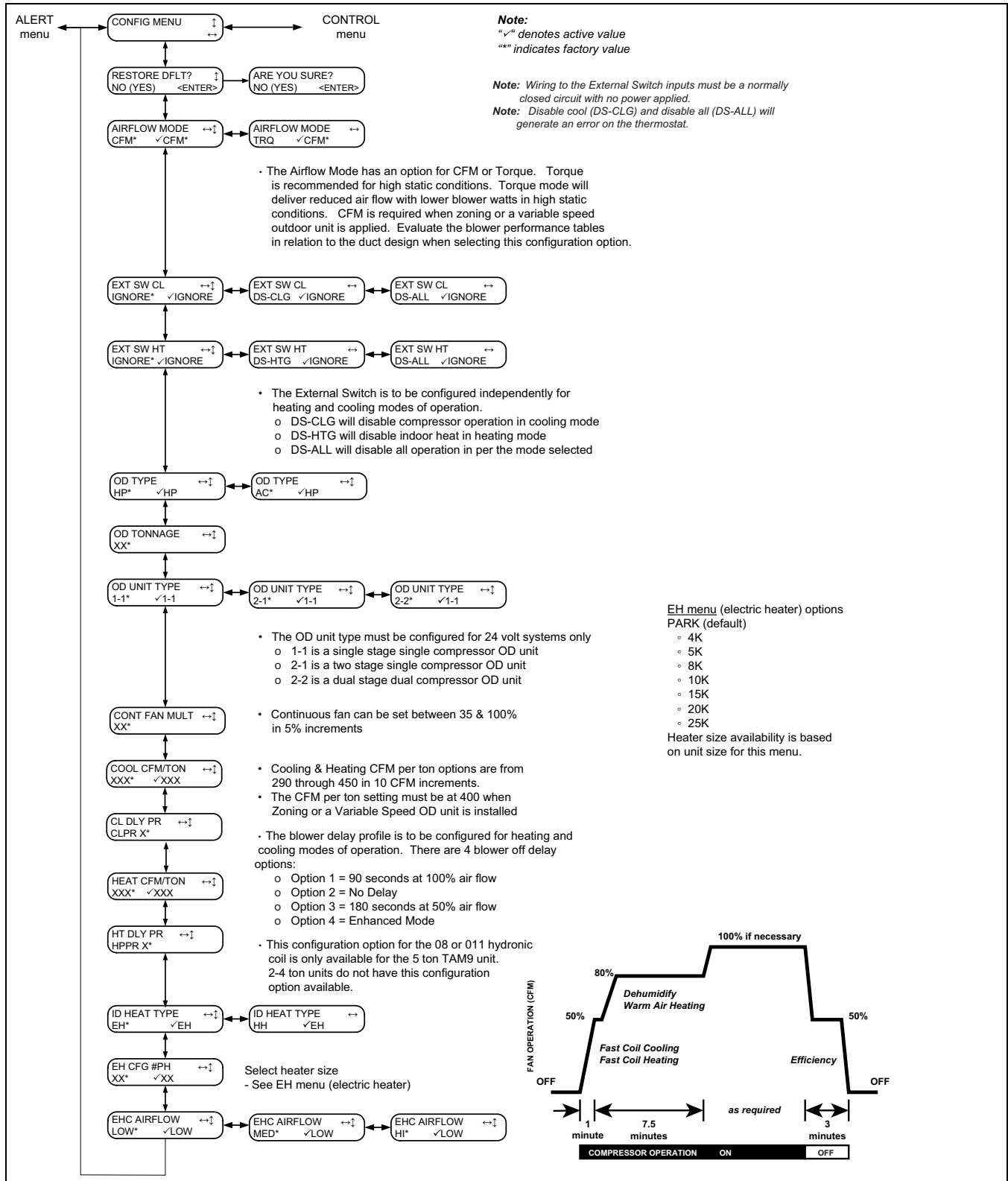

Table 16. CDA Alert Menu



- The Alert menu allows the technician to view active and historical faults that have occurred. Alerts are grouped by the control declaring the fault.
    - AFC
    - EVC
    - DA
  - The first line of text contains the description of the fault and the component that reported it. The abbreviations for the components are:
    - AF = Air Flow control
    - EV = Expansion Valve control
    - DA = Display Assembly
  - The second line of text contains any action that may take place because of the fault and the order that the faults occurred. Some faults will shut-down all or part of the system. See the System Actions below.
    - AH = Auxiliary Heat is prohibited (electric or hydronic)
    - CH = Compressor Heat is prohibited
    - CC = Compressor Cooling is prohibited
    - CB = Compressor Heat and Cooling is prohibited
    - BI = Blower operation is prohibited\*
    - \* Applies only to states that are prohibited
  - Timestamp (DDDD:HH:MM:SS)
    - The elapsed time the fault occurred from when the unit was installed.
  - COUNT
    - The number of times the fault has occurred.
- Note:** When the fault history is cleared, the COUNT will also be cleared.

Table 17. CDA Config Menu



**Table 18. CDA Control Menu**

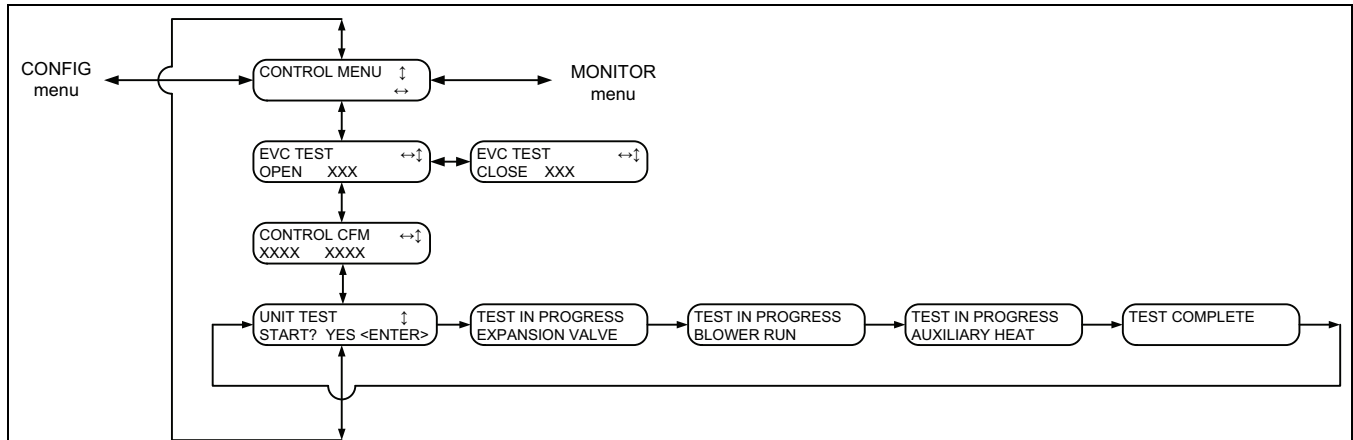

- EVC TEST: Scroll to desired test and push the <Enter> key.
  - o OPEN - When selected, the EEV will drive to the full open position (OPEN 500).
  - o CLOSE - When selected, the EEV will drive to the closed position (CLOSE 056).
- CONTROL CFM: Press <Enter> key to initiate control.
  - o First value is current selection, Second value is actual airflow.
  - o Use left or right menu keys to decrease or increase airflow in 100 CFM increments.
  - o Press ENTER to initiate new CFM demand. Actual airflow is updated every six seconds.
- UNIT TEST: Press <Enter> key to initiate test. (Unit must be in Standby or Idle mode)
  - o Once test is started, the screen update automatically and navigation is not allowed.
  - o UNIT TEST may only be interrupted by a thermostat demand or turning off the power.

**NOTE:** EVC TEST and/or AUX HEAT TEST will be skipped if the associated control(s) id?are not discovered.

# Start Up

## System Charge Adjustments

System Matched with:	Indoor Unit Model No.	Outdoor Unit Model No.	Subcooling
Single Compressor 2-Stage HP	TAM9A0B30V31DB	4A6H6024E/G, 4TWX6024E/G, 4A6H7024, 4TWX8024	9°
	TAM9A0C36V31DB	4A6H6036E/G, 4TWX6036E/G, 4A6H7036, 4TWX8036	10°
	TAM9A0C48V41DB	4A6H6048E/G, 4TWX6048E/G, 4A6H7048, 4TWX8048	8°
Single Compressor 2-Stage AC	TAM9A0B30V31DB	4A7A6024E/G, 4TTX6024E/G, 4A7A7024, 4TTX8024	8°
	TAM9A0C36V31DB	4A7A6036E/G, 4TTX6036E/G, 4A7A7036, 4TTX8036	8°
	TAM9A0C48V41DB	4A7A6048E/G, 4TTX6048E/G, 4A7A7048, 4TTX8048	8°
Two Compressor 2-Stage HP	TAM9A0B30V31DB	4A6Z0024A, 4TWZ0024A	9°
	TAM9A0C36V31DB	4A6Z0036A/B, 4TWZ0036A/B	10°
	TAM9A0C48V41DB	4A6Z0048A/B, 4TWZ0048A/B	12°
	TAM9A0C60V51DB	4A6Z0060A, 4TWZ0060A	12°
Two Compressor 2-Stage AC	TAM9A0B30V31DB	4A7Z0024A, 4TTZ0024A	9°
	TAM9A0C36V31DB	4A7Z0036A/B, 4TTZ0036A/B	11°
	TAM9A0C48V41DB	4A7Z0048A/B, 4TTZ0048A/B	12°

**NOTES:**

1. Variable Speed outdoor units must be charged per the outdoor unit instructions.
2. All other matches must be charged per the nameplate charging instructions.

## System Start Up

1. Make sure all panels are securely in place and that all wiring has been properly dressed and secured.
2. Set the system thermostat to OFF.

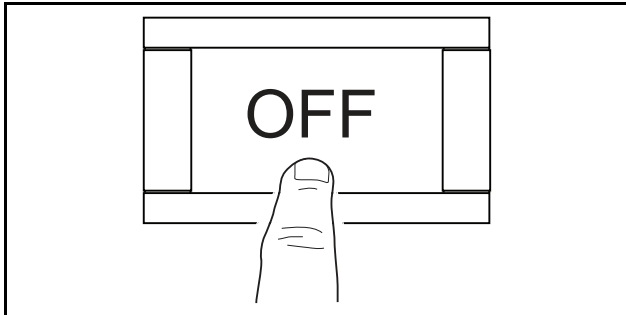

3. Turn on electrical power disconnect(s) to apply power to the indoor and outdoor units.

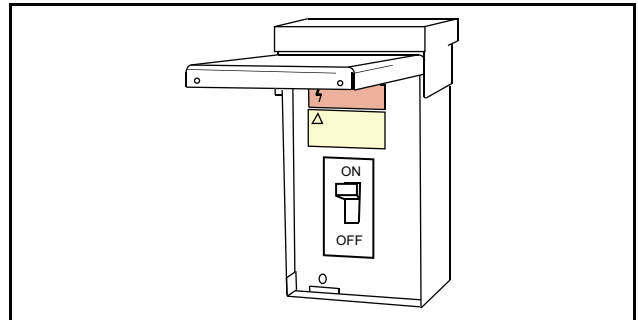

4. Set the system thermostat to ON.

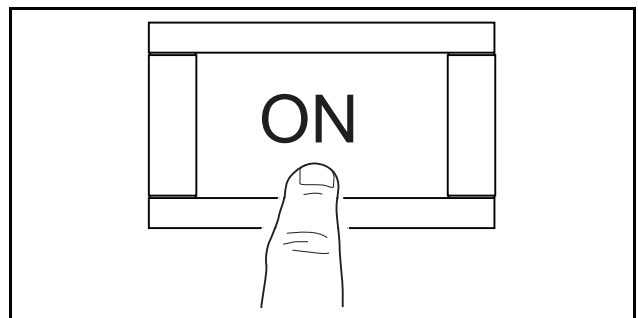

# Sequence of Operation

## Abbreviations

- AFC = Airflow Control
- EVC = Expansion Valve Control
- EEV = Electronic Expansion Valve

**Note:** When used with variable speed outdoor units, indoor airflow and EEV starting position is controlled by the outdoor unit IVSC through the data line between the units.

**Note:** Use variable speed outdoor Sequence of Operation in conjunction with the TAM9 Sequence of Operation.

The installing and servicing technician should have an understanding of the sequence of operation to be able to properly setup and diagnose functions of the air handler.

**See unit, electric heat, and field wiring diagrams for additional information.**

## Continuous Fan

**Important:** If the indoor air exceeds 60% relative humidity or simply feels uncomfortably humid, it is recommended that the indoor fan only be used in the AUTO mode.

1. When a fan request is received from the thermostat, the AFC sends a command to the serial communicating blower motor to run. Airflow can be adjusted through the thermostat.
2. Humidity Control – When enabled at the thermostat, this feature will disable any blower off delays and disable continuous fan mode when the humidity is above the dehumidification setpoint. This will help prevent coil condensation from being evaporated back into the air stream.

## Cooling Mode

1. When a request for 1st stage cooling is received, the AFC sends a command to the serial communicating blower motor to run at 1st stage cooling airflow. (Delay profiles from the thermostat may change blower motor timing and actual airflow demand)
2. The EVC will receive input from the two temperature sensors and start to control 1st stage superheat. .
3. When a request for 2nd stage cooling is received, the AFC sends a command to the serial communicating blower motor to run at 100 % cooling airflow.
4. The EVC will now control superheat for 2nd stage.
5. When a request for cooling is removed, the AFC will turn off the blower motor after any user selected fan-off delays have expired.

**Note:** Delay profiles from the thermostat may change blower motor timing and actual airflow demand.

## Heat pump (compressor only)

1. When a request for 1st stage heat is received, the AFC sends a command to the serial communicating blower motor to run at 1st stage heating airflow.
2. Humidifier contacts close on demand from thermostat.
3. The EVC will drive the EEV to the heating position and refrigerant will flow in the reverse cycle.
4. When a request for 2nd stage mechanical heat is received, the AFC sends a command to the serial communicating blower motor to run at 100 % heating airflow.
5. When a request for heat pump is removed, the AFC will turn off the blower motor after any user selected fan-off delays have expired.

**Note:** Delay profiles from the thermostat may change blower motor timing and actual airflow demand.

## Electric Heat

1. When a request for electric heat is received, the AFC will energize the on board 24 volt relays per the amount of heat requested from the thermostat and the size of the heater installed.
2. The AFC sends a command to the serial communicating blower motor to run proper airflow and close the blower interlock relay on the EHC.

## Hydronic Heat

1. When a request for hydronic heat is received, the AFC will energize the on board W1 relay.
2. The AFC sends a command to the serial communicating blower motor to run at the requested CFM.

## Defrost

1. The OD unit will initiate defrost and send a message to the AFC.
2. The AFC will communicate to the EVC that the OD is in defrost and the EVC will start to control the correct superheat.
3. Electric or hydronic heat will be energized to help temper the air.

## Freeze Protection

1. The EVC control has the ability to sense when the indoor coil is beginning to ice. If this event should occur, the AFC will send a message to de-energize the OD unit.
2. The indoor blower motor will continue running to aid in defrosting the coil.

- After 5 minutes, the OD will be turned back on.  
(\*CONT900 and the 1st release of the \*ZONE950 will disable the indoor blower motor and OD unit for 30 minutes)

### Unit Test Mode

Unit Test Mode will exit if any demand is given to the unit.

To enter Unit Test Mode:

- Set System Switch on comfort control to Off.
- Scroll to the Control Menu on the Display Assembly.
- Scroll down to the Unit Test selection and push the "Enter" button.

### Sequence of Unit Test Mode (OD unit is not energized during the Unit Test Mode)

- EVC drives the EEV motor to the 1st stage position for 5 seconds.
- EVC drives the EEV motor to the 2nd stage position for 5 seconds.
- AFC energizes the blower at 50% and then continues to ramp until it reaches 100% cooling airflow.
- Humidifier contacts close when the blower starts.
- AFC energizes the W relays in 10 second intervals. The blower remains at 100% air flow.
- All relays de-energize and the blower shuts off five seconds after the last bank of heat is energized.

**Note:** If an error occurs during the Unit Test Mode, the Fault LED will flash a code and continue the test.

## Fault Reporting

### Fault Reporting

Control boards in this unit store active and historical faults. Each control board will report active faults continuously and will report the last four faults stored after a power cycle of the unit. See Fault Table in the Service Facts for list of fault codes.

The active and historical faults can also be accessed through the Alert Menu in the Display Assembly.

### Clearing Fault History

Option 1:

- Scroll to the Alert Menu in the Display Assembly.
- Scroll to the Alert History section.
- Scroll to the Clear History selection and push the Enter key. At the "Are You Sure" question, push the Enter again.

Option 2:

- Press and hold the Unit Test Button for 10-12 seconds.
- Release the Unit Test button and wait 5 seconds.
- Cycle 230VAC power to the unit. (the blower panel can be removed to achieve this)

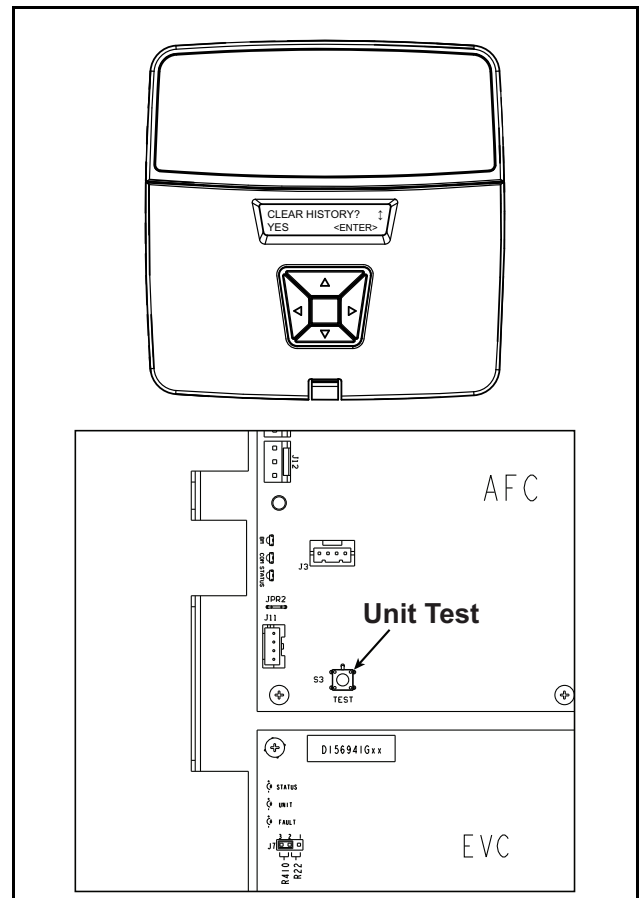

# Checkout Procedures

The final phase of the installation is the system Checkout Procedures. The following list represents the most common items covered in a Checkout Procedure. Confirm all requirements in this document have been met.

<ul style="list-style-type: none"><li><input type="checkbox"/> All wiring connections are tight and properly secured.</li><li><input type="checkbox"/> Voltage and running current are within limits.</li><li><input type="checkbox"/> Heater size has been configured in the Configuration Menu.</li><li><input type="checkbox"/> All refrigerant lines (internal and external to equipment) are isolated, secure, and not in direct contact with each other or structure.</li><li><input type="checkbox"/> All braze connections have been checked for leaks. A vacuum of 350 microns provides confirmation that the refrigeration system is leak free and dry.</li><li><input type="checkbox"/> Final unit inspection to confirm factory tubing has not shifted during shipment. Adjust tubing if necessary so tubes do not rub against each other or any component when unit runs.</li><li><input type="checkbox"/> Ductwork is sealed and insulated.</li><li><input type="checkbox"/> All drain lines are clear with joints properly sealed. Pour water into drain pan to confirm proper drainage.</li></ul>	<ul style="list-style-type: none"><li><input type="checkbox"/> Supply registers and return grilles are open, unobstructed, and air filter is installed.</li><li><input type="checkbox"/> Indoor blower and outdoor fan are operating smoothly and without obstruction.</li><li><input type="checkbox"/> Indoor blower motor set on correct speed setting to deliver required CFM.</li><li><input type="checkbox"/> Cover panels are in place and properly tightened.</li><li><input type="checkbox"/> For gas heating systems, manifold pressure has been checked and all gas line connections are tight and leak free.</li><li><input type="checkbox"/> For gas heating systems, flue gas is properly vented.</li><li><input type="checkbox"/> System functions safely and properly in all modes.</li><li><input type="checkbox"/> Owner has been instructed on use of system and given manual.</li></ul>
---	--

This product may be covered by one or more of the following patents and their foreign equivalents: 5621888, 5901156, 6208263, 6353376, and 6448901. Other patents are pending. Made under license.

## About Trane and American Standard Heating and Air Conditioning

Trane and American Standard create comfortable, energy efficient indoor environments for residential applications. For more information, please visit [www.trane.com](http://www.trane.com) or [www.americanstandardair.com](http://www.americanstandardair.com).



The manufacturer has a policy of continuous data improvement and it reserves the right to change design and specifications without notice. We are committed to using environmentally conscious print practices.