

INSTALLER'S GUIDE

18-GJ22D1-1E-EN

ALL phases of this installation must comply with NATIONAL, STATE AND LOCAL CODES

Models:
BAYEACC25BK1B

25 kW Supplementary Electric Heater for Air Handler Installations

IMPORTANT – This Document is customer property and is to remain with this unit. Please return to service information pack upon completion of work.

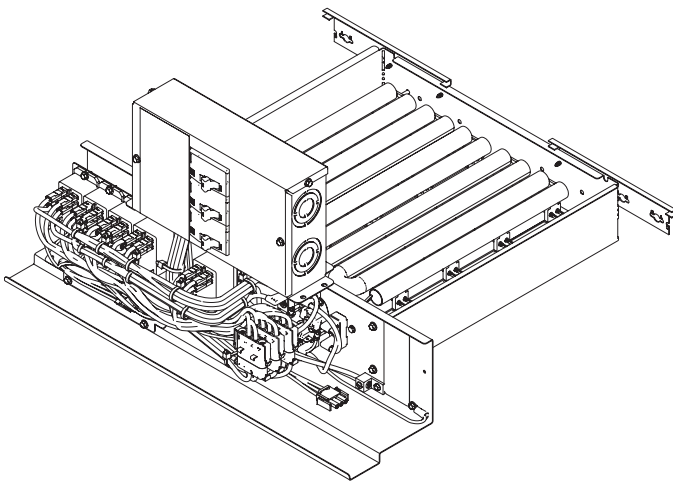

Table of Contents

Section 1. Safety Information	1
Section 2. General Information.....	2
Section 3. Heater Assembly Labeled.....	2
Section 4. Adjust Heater.....	3
Section 5. Install Heater.....	5
Section 6. Tables.....	11
Section 7. Sequence of Operation.....	12

Section 1. Safety Information

⚠ WARNING

SAFETY HAZARD! This information is intended for use by individuals possessing adequate backgrounds of electrical and mechanical experience. Any attempt to repair a central air conditioning product may result in personal injury and/or property damage. The manufacturer or seller cannot be responsible for the interpretation of this information, nor can it assume any liability in connection with its use.

⚠ WARNING

HAZARDOUS VOLTAGE! Disconnect all electric power, including remote disconnects before servicing. Follow proper lockout/tagout procedures to ensure the power can not be inadvertently energized. Failure to disconnect power before servicing could result in death or serious injury.

⚠ WARNING

LIVE ELECTRICAL COMPONENTS! During installation, testing, servicing, and troubleshooting of this product, it may be necessary to work with live electrical components. Failure to follow all electrical safety precautions when exposed to live electrical components could result in death or serious injury.

⚠ CAUTION

SAFETY HAZARD! Sharp Edge Hazard. Be careful of sharp edges on equipment or any cuts made on sheet metal while installing or servicing. Personal injury may result.

Section 2. General Information

This electric heater accessory is designed to provide power directly to the air handler from the accessory heater's power supply, eliminating the need for additional circuits. The power and control wiring each use a single wire harness to connect the heater and the air handler.

1. Check the heater nameplate to confirm that the selected heater is approved for use with the air handler.
2. Check the components received for damage. Report any defects or shortages to the transportation company immediately.
3. Be sure the power supply matches the listing shown on the heater nameplate.

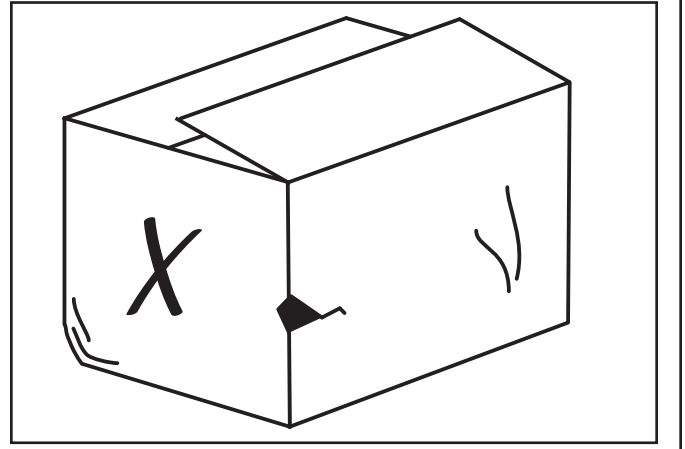

Section 3. Heater Assembly Labeled

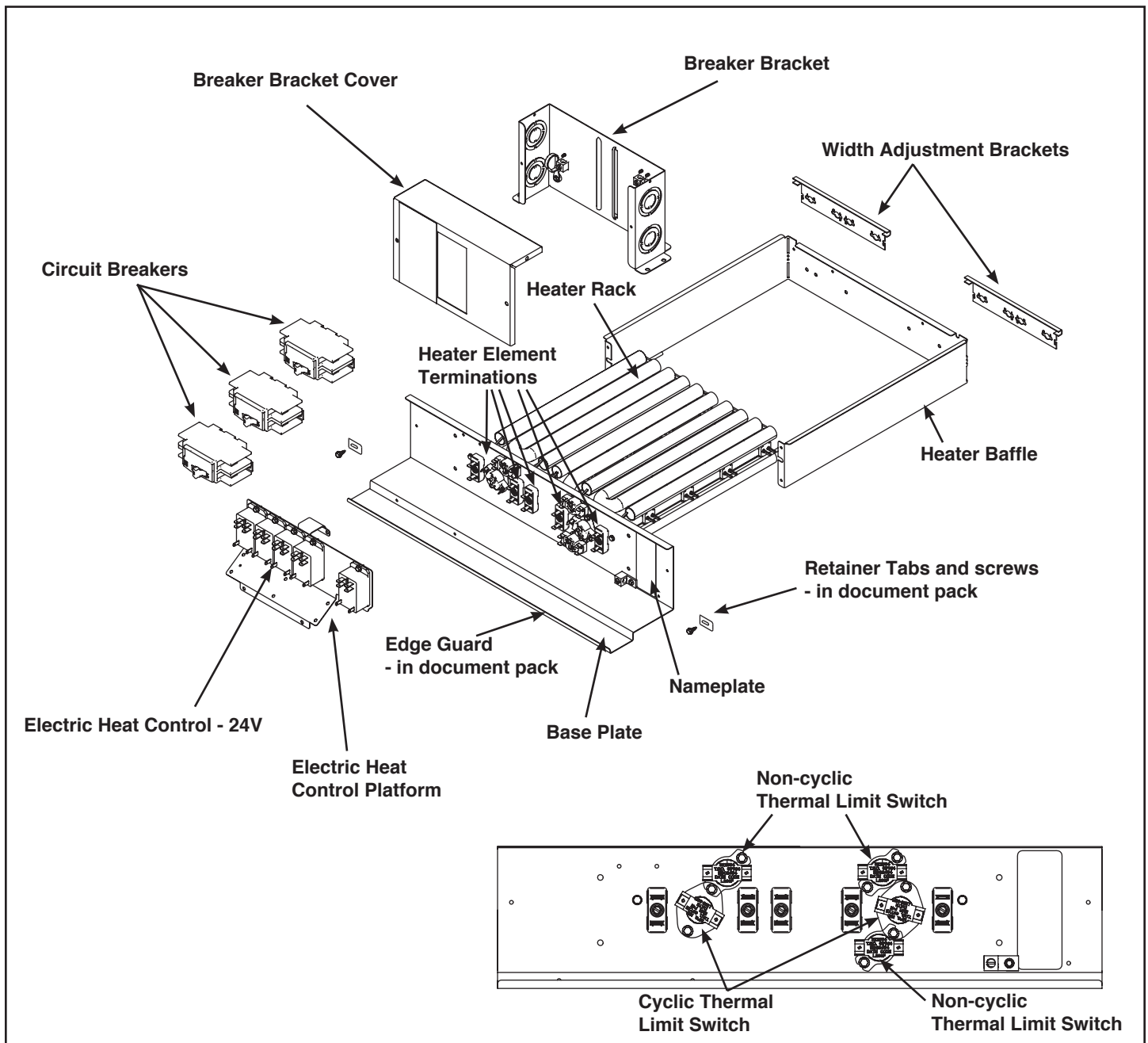

Section 4. Adjust Heater

STEP 1 - Remove control box

The heater and control box are connected when they are shipped. Before installation is started, the control box must be disconnected from the heater.

1. Disconnect the three 4-pin plugs between the breakers and the heater. (Shown removed in illustration.)
2. Disconnect the ground on the 3-pin plug that is at the right front of the heater and connected with a ring terminal to the heater base plate.
3. Disconnect the two ground wires from the lug on the heater base plate.

Note: It is recommended that the ducting be attached and sealed before installing the heater.

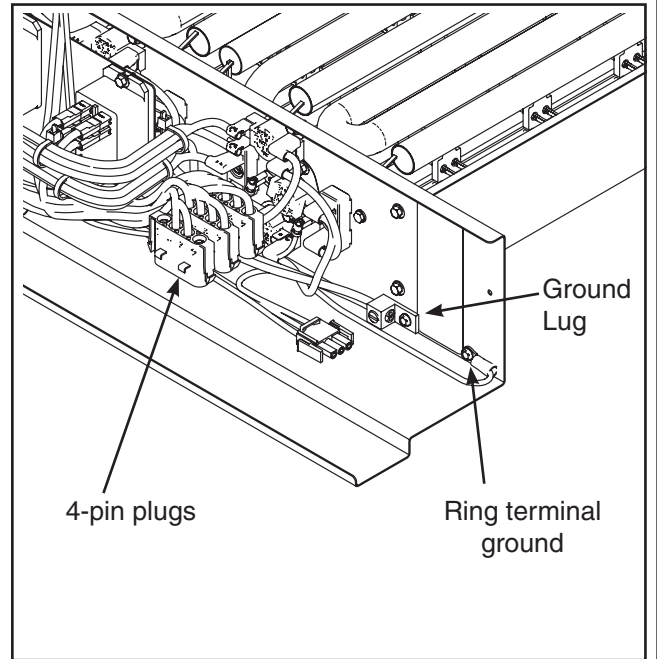

STEP 2 - Adjustment brackets

Two Width Adjustment Brackets are located at the back of the heater assembly. The heater comes factory sized for the C cabinet. No modifications to the Width Adjustment Brackets are required.

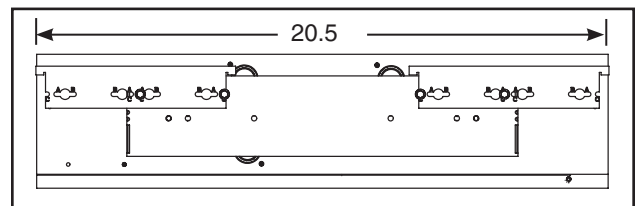
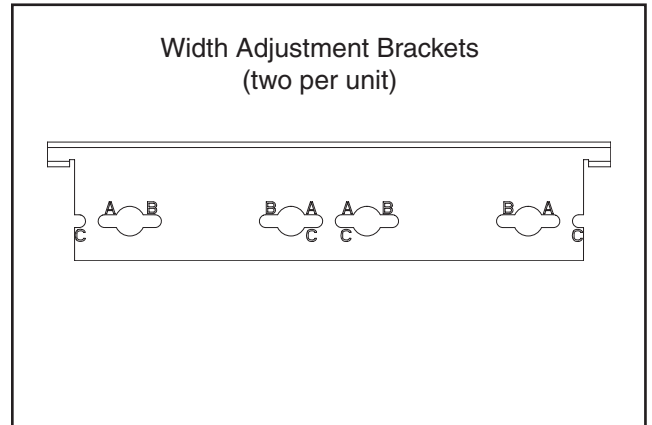

STEP 3 - Attach Retainer Tabs.

1. Add the Retainer tabs using the screws provided (both tabs and screws are located in the documentation packet).

Leave the screws slightly loose so that the tab can slide to the left or right as needed. The tab will be used later to engage in a slot within the air handler cabinet.

Note: The retainer tabs must be attached to the heater base plate. Leave the screws slightly loose so they can be slid to the left or right as needed.

2. The edge guard is located in the document pack. Install the edge guard on the front of the heater flange as shown.

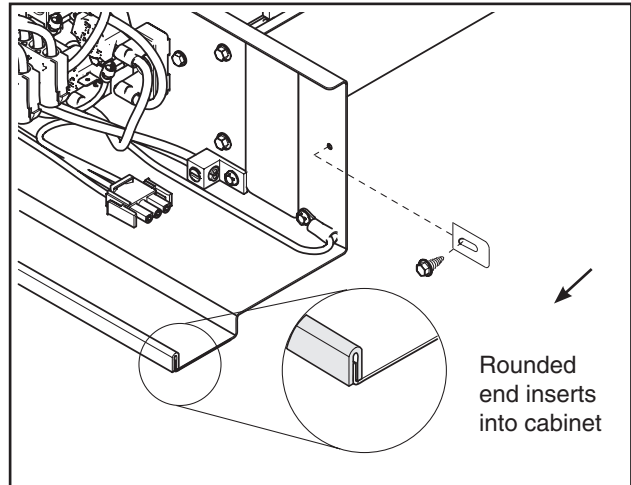

STEP 4 - (Optional) Rotate Circuit Breakers.

The need to reorient the Circuit Breaker Assembly depends upon the orientation of your application and which of the high voltage electrical conduit entry points you use for high voltage wiring.

Important: For air handler units installed in the horizontal right position, the circuit breakers on the heater must be rotated in order to comply with National Electric Code (NEC Section 240.81). The NEC requires that circuit breakers operated vertically must be oriented so that the "on" position of the breaker is upward.

⚠ CAUTION

SAFETY HAZARD! Sharp Edge Hazard. Be careful of sharp edges on equipment or any cuts made on sheet metal while installing or servicing. Personal injury may result.

1. Pull out the tab on the back side of the breaker using a long screwdriver.
2. Remove the circuit breaker from the control box and rotate the circuit breakers 180 °.

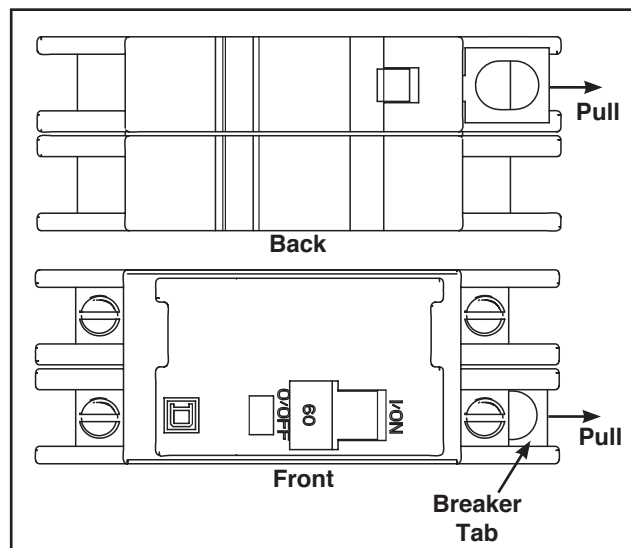
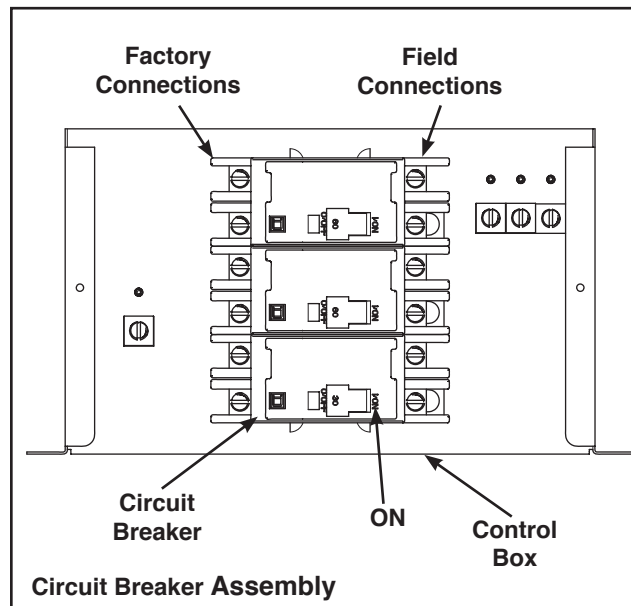

- Place the circuit breakers back into the control box. The tabs on the breakers are spring loaded and will snap back to their locked position once the breakers are properly seated.

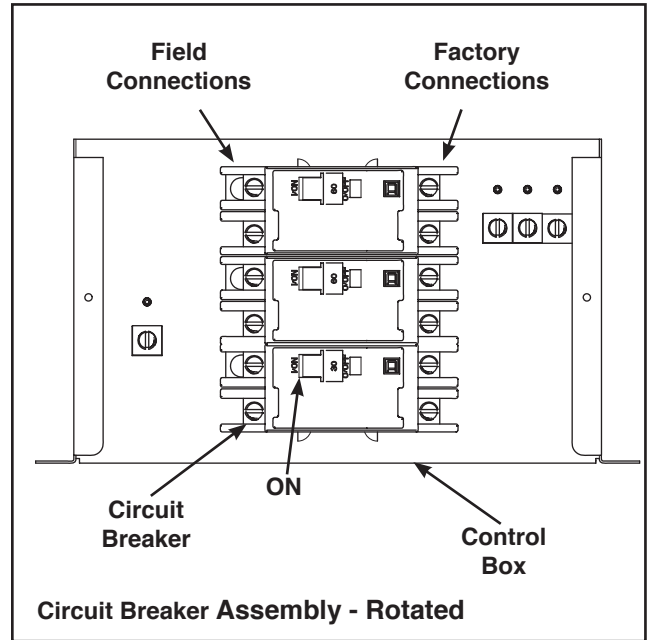

Section 5. Install Heater

STEP 1 - Remove Heater Compartment Panel.

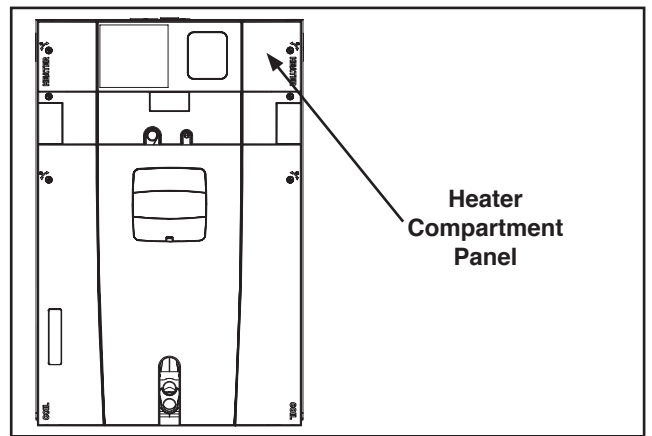

STEP 2 - Disconnect & Dispose of Pigtail Harness.

- Remove the screw mounted wire tie that is holding the pigtail harness and case ground wire to the cabinet. Remove the wire tie from the two green ground wires.
- Unplug and dispose of pigtail harness.

Note: If there is not a conduit plug in the top cross-member, drill a 2" diameter hole in the top panel to feed the wires through. Use the conduit locating target for the location of the 2" diameter hole.

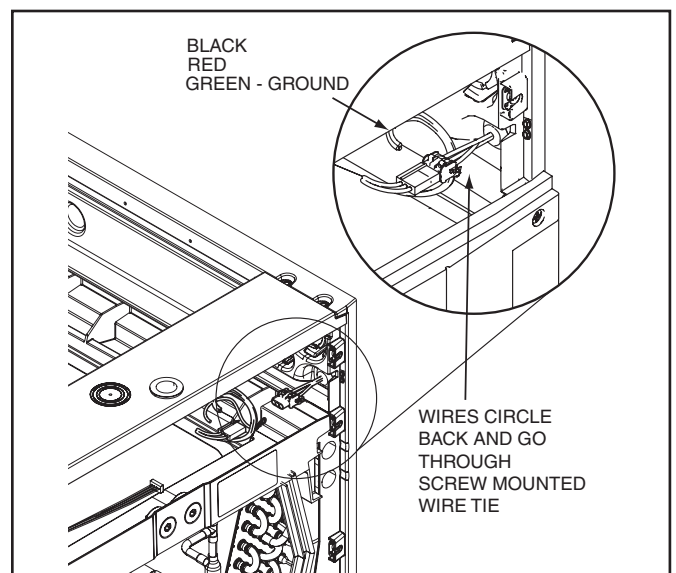

STEP 3 - Insert heater assembly into heater compartment.

1. Move factory wiring out of the way and into the grooves provided in cabinet.
2. Slide heater into heater compartment of air handler.

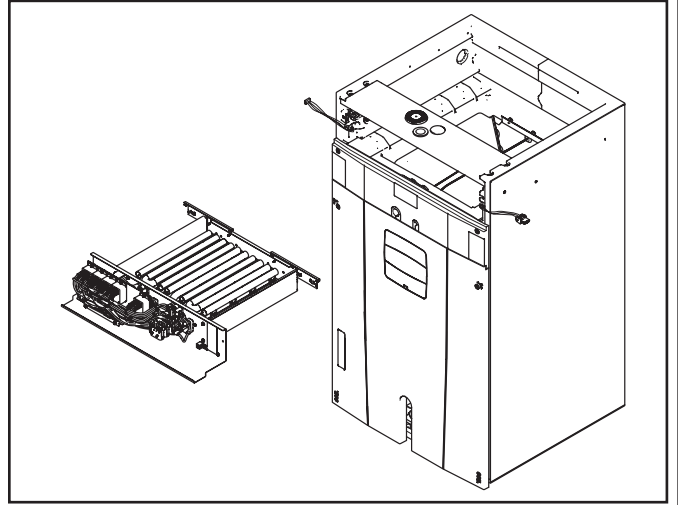

STEP - 4 Lock Retainer tabs.

Note: Retainer tabs are used to secure the heater inside of the heater compartment.

1. Slide retainer tab into recess in air handler cabinet.
2. Tighten screws to hold tab securely.
3. Repeat actions to secure the other tab.

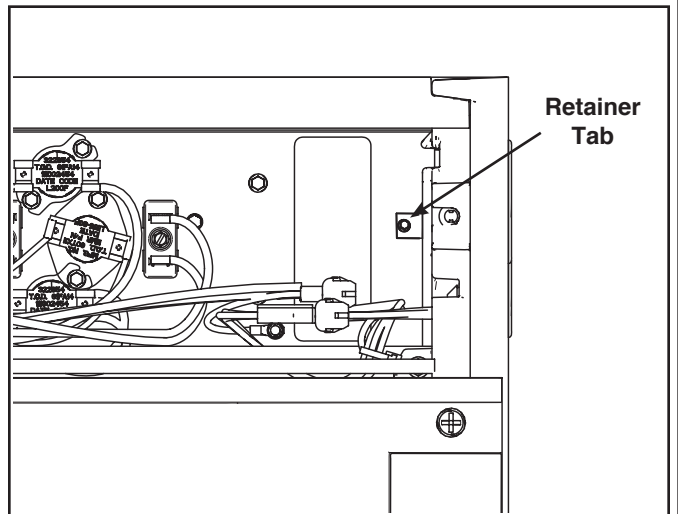

STEP 5 - Select a conduit entry point. See the orientations on the following pages for entry point selections.

1. Select the entry point on the control box cover you will use to bring in your high voltage wiring.
2. Remove knockout from the entry point.
3. Remove the plug from the 1-1/2" hole in the cabinet.
4. After the ductwork is installed, secure the control box to the top panel of the air handler.

Note: Use the low torque setting when attaching the screws to the unit.

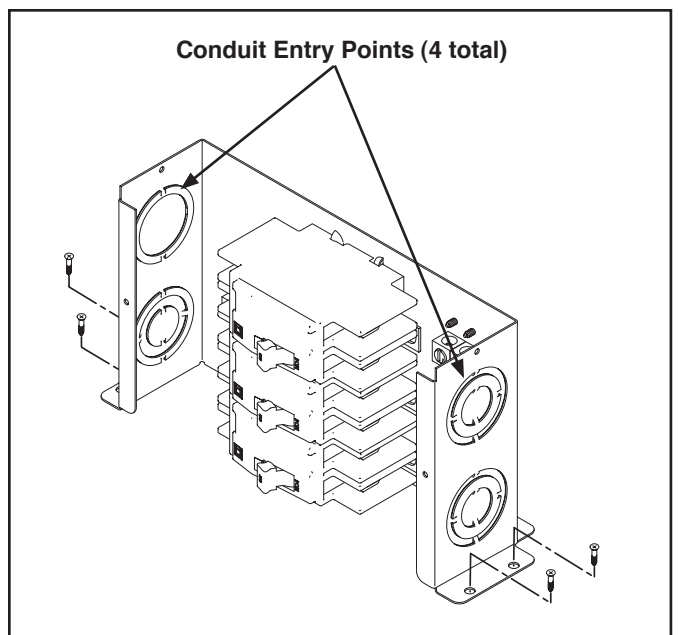

Upflow - Route conduit, as shown.

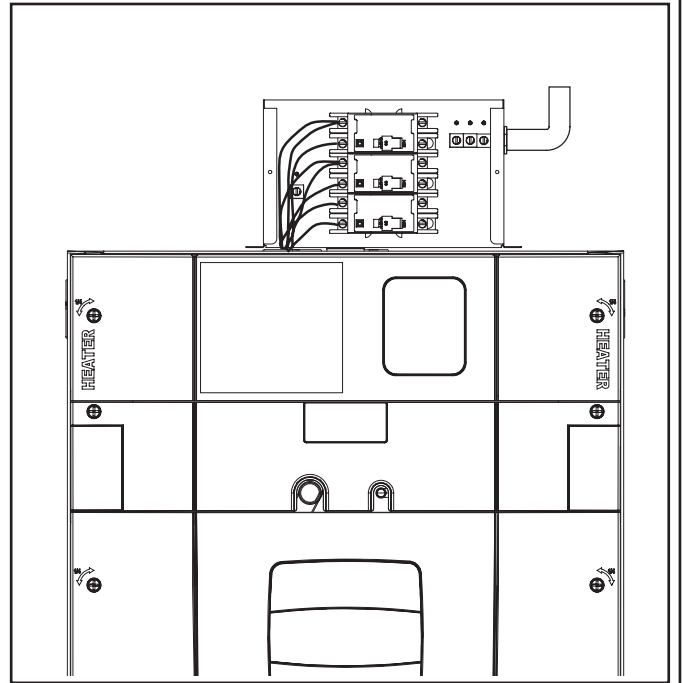

Downflow - Route conduit, as shown.

Note: A minimum of 8" is required for installation and servicing of the control box.

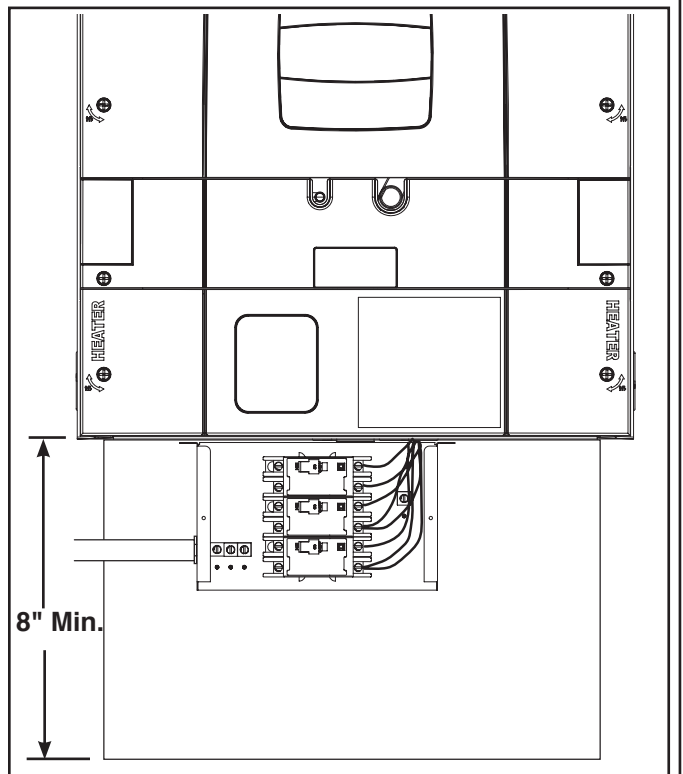

Horizontal Left - Route conduit, as shown.

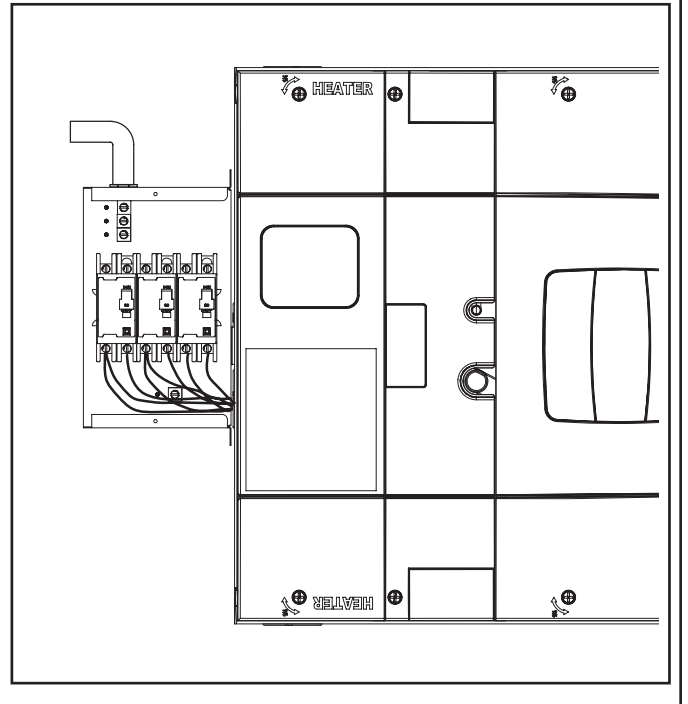

Horizontal Right - Route conduit, as shown.

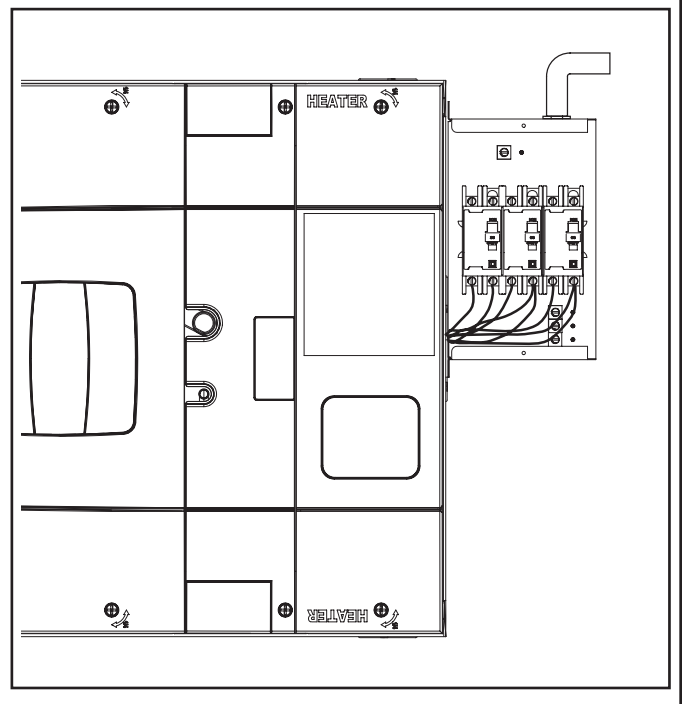

STEP 6 - Route conduit, if used, and wiring to the entry point and connect.

1. Connect field supplied conduit to breaker box.

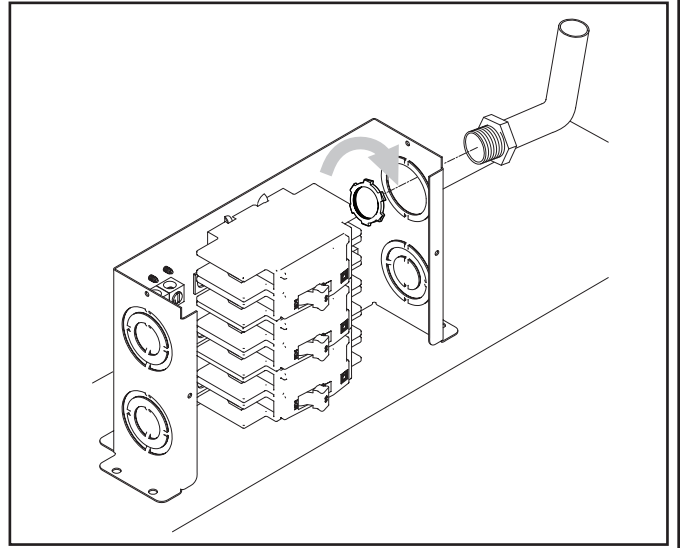

STEP 7 - Connect high voltage wiring

1. Connect high voltage field wiring.
2. Route the three 4-pin connectors, one 3-pin connector, and two ground wires through the hole in the top panel.
3. Reconnect the ground wire coming from the 3-pin connector to the heater base plate front using the screw removed earlier. (See Section 4, Step 1 for illustration)
4. Reconnect the 3-pin plug on the heater to the 3-pin plug in the air handler case.
5. Reconnect the two ground wires to the lug on the base plate. See illustration in Step 8.

Note: Minimum terminal screw torque is 45 in-lbs.

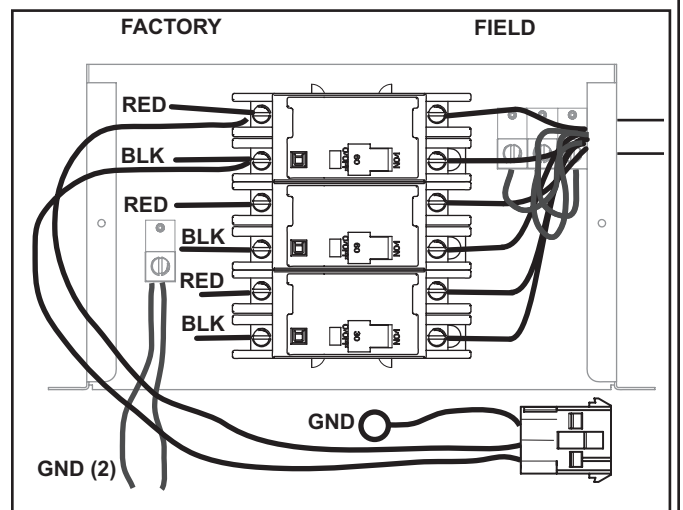

STEP 8 - Plug Connections

1. Connect the three 4-pin connectors from the circuit breakers to the three 4-pin connectors coming from the heater. The connectors are labeled "Circuit1", "Circuit 2", and "Circuit 3". Line up the mating male and female connectors and connect.

Note: One set of plugs has only two wires each.

2. Connect the case ground wire to the lug on the heater base plate.

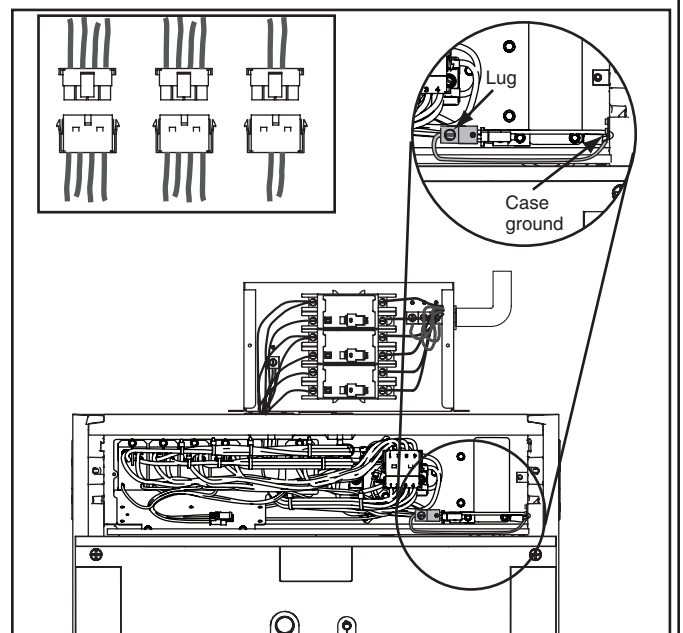

STEP 9 - Connect low voltage wiring.

1. Connect the 4-pin low voltage harness to Electric Heat Control as shown.
2. If installing in TAMX Air Handler models, connect the 2-pin resistor ID assembly (tie wrapped to Electric Heat Controls harness) into the 2-pin heater ID harness as shown.
3. All other Air Handler models, the 2-pin resistor ID assembly is not used and should be left disconnected.

Close up with other wires not shown

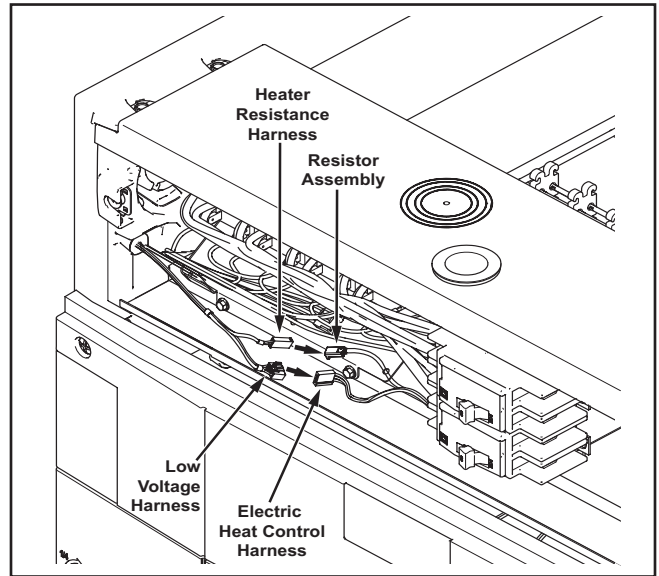
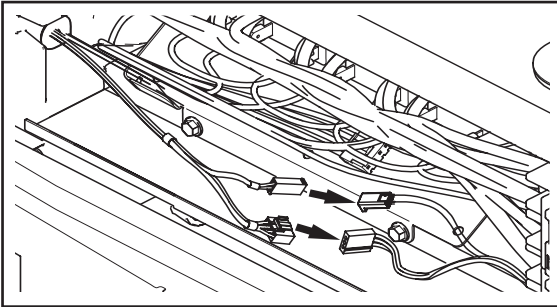

STEP 10 - Place Wiring Diagram.

1. Attach the wiring diagram, included in the documentation packet, to the back of the heater compartment panel.

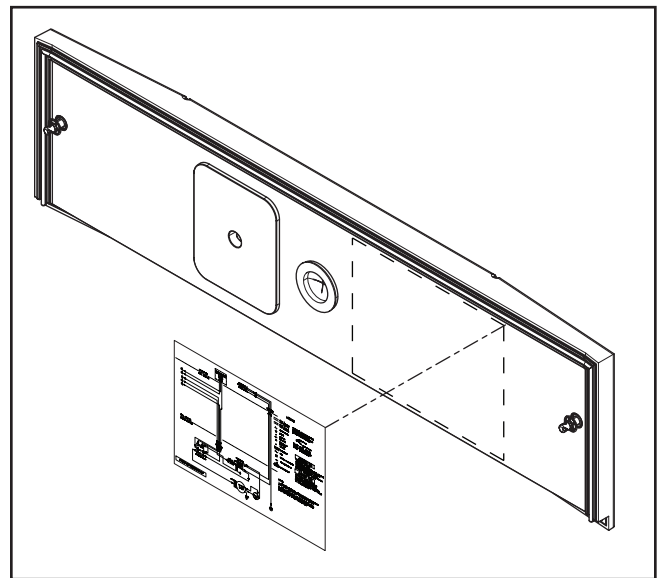

STEP 11 - Replace Heater compartment panel on air handler.

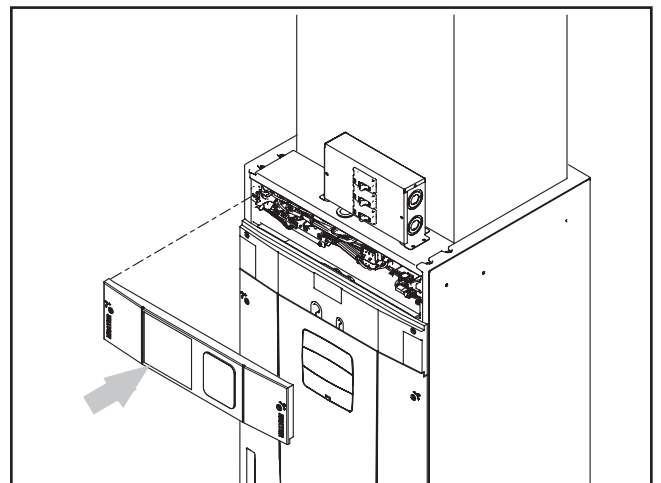

STEP 12 - For the TAM9 and TAMGB only, set the heater size in the Configuration Menu.

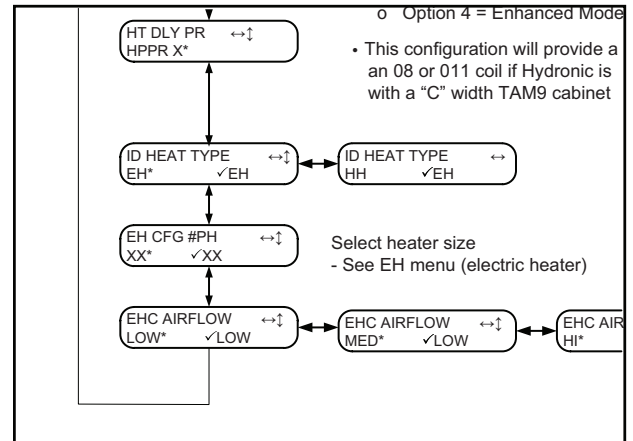

Section 6. Tables

Important: The BAYEA* electric heat accessory may include up to a combination of three 60 amp circuit breakers to provide an electrical disconnect for service personnel that is intended to help protect internal electrical components in the event of a short circuit or ground fault. As designed, the circuit breakers supplied in the BAYEA* accessory **DO NOT** provide overcurrent protection of the branch circuit. Therefore, the branch circuit(s) shall be sized and protected according to the unit nameplate.

Table 6.1 BAYEA -- HEATER DATA

Heater Model No.	Number of Circuits	240 VOLT			208 VOLT		
		Capacity		Heater Amps per Circuit	Capacity		Heater Amps per Circuit
		kW	BTUH		kW	BTUH	
BAYEACC25BK1	3	24.00	82000	40/40/20	18.00	61500	34.6/34.6/17.3

Table 6.2 MINIMUM HEATER AIRFLOW CFM - HEATER MATRIX

MODEL NO.	BAYEACC25BK1
	W/O HP / WITH HP
GAM5B0C48M41E	TAP 4 / TAP 5
GAM5B0C60M51E	TAP 4 / TAP 5 ①②
TAM4A0C48S41E	TAP 2 ③ / TAP 3
TAM4A0C60S51E	TAP 4 / TAP 5
TAM9A0C48V41D TAMXA0C48V41D	1625 / 1813
TAM9A0C60V51D TAMXA0C60V51D	1625 / 1813
TAMGB0C48V41D	1625 / 1813
TAMGB0C60V51D	1625 / 1813

SEE AIR HANDLER NAMEPLATE OR PRODUCT DATA FOR EXCEPTIONS

① If the air handler is applied in downflow or horizontal configurations, the airflow should not exceed 2000 CFM. Airflow above 2000 CFM could result in water blow-off.

② Tap 5 can be used but only when the external static pressure is .6" or above.

③ Not approved for 208V

NOTE: TAM9, TAMX and TAMGB are variable speed air handlers

Section 7. Heater Operation

7.1 GAM5B Heater Operation

Electric Heating

1. R-W contacts close on the comfort control sending 24VAC to the W terminal on the TDR. 24VAC is also sent to EHC to energize the heat relay.
2. R-G contacts close on the comfort control sending 24VAC to the G terminal on the TDR. (The combination of 24VAC on terminals W and G on the TDR will close the high speed contacts of the TDR)
3. WJ contacts on the TDR close providing an interlock circuit to allow the electric heat relays to operate.

The comfort control must be setup to control R-G contacts with a call for electric heat. This closes the interlock circuit and allows the heat relay circuit to be energized.

7.2 TAM4 Heater Operation

Electric Heating

1. R-W contacts close on the comfort control sending 24VAC to the EHC to energize the heat relay.
2. R-G contacts close on comfort control sending 24VAC to the blower relay
3. Relay contacts 1 and 3 close
4. The blower will now run on the selected speed. Speed is field selectable
5. Contacts 4 & 6 on the blower relay close providing the interlock circuit to allow the electric heat relays to operate

The comfort control must be setup to control R-G contacts with a call for electric heat. This closes the interlock circuit and allows the heat relay circuit to be energized.

7.3 TAM9, TAMX / TAMGB Heater Operation

Electric Heating

Note: The TAM9, TAMX / TAMG can use a communicating or 24 volt comfort control to send a heater request to the AFC/AHC.

1. When a request for electric heat is received, the AFC/AHC will energize the on board 24 volt relays per the amount of heat requested from the thermostat and the size of the heater installed.
2. The AFC/AHC sends a command to the serial communicating blower motor to run proper airflow and close the blower interlock relay on the EHC.

About Trane and American Standard Heating and Air Conditioning

Trane and American Standard create comfortable, energy efficient indoor environments for residential applications. For more information, please visit www.trane.com or www.americanstandardair.com

The manufacturer has a policy of continuous data improvement and it reserves the right to change design and specifications without notice. We are committed to using environmentally conscious print practices.