

INSTALLER'S GUIDE

18-GJ08D1-10C-EN

ALL phases of this installation must comply with NATIONAL,
STATE AND LOCAL CODES

Models:

BAYE AAC04BK1B	BAYE AAC10BK1B
BAYE AAC04LG1B	BAYE AAC10LG1B
BAYE AAC05BK1B	BAYE AAC10LG3B
BAYE AAC05LG1B	BAYE ABC15BK1B
BAYE AAC08BK1B	BAYE ABC15LG3B
BAYE AAC08LG1B	BAYE ABC20BK1B

Supplementary Electric Heaters for Air Handler Installations

IMPORTANT — This Document is customer property and is to remain with this unit. Please return to service information pack upon completion of work.

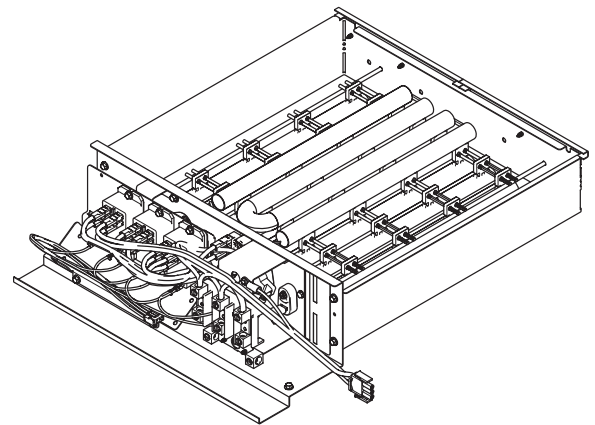
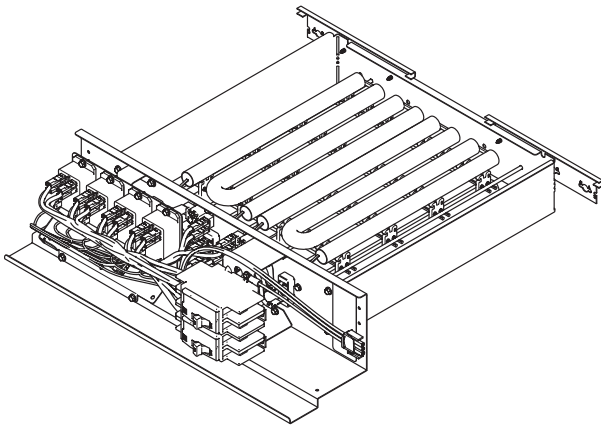

Table of Contents

Section 1. Safety Information	2
Section 2. General Information	3
Section 3. Heater Assembly Labeled	3
Section 4. Heater Selection	4
Section 5. Adjust Heater	6
Section 6. Install Heater	8
Section 7. Tables	14
Section 8. Sequence of Operation	16

Section 1. Safety Information

WARNING

SAFETY HAZARD! This information is intended for use by individuals possessing adequate backgrounds of electrical and mechanical experience. Any attempt to repair a central air conditioning product may result in personal injury and/or property damage. The manufacturer or seller cannot be responsible for the interpretation of this information, nor can it assume any liability in connection with its use.

WARNING

HAZARDOUS VOLTAGE! Disconnect all electric power, including remote disconnects before servicing. Follow proper lockout/tagout procedures to ensure the power can not be inadvertently energized. Failure to disconnect power before servicing could result in death or serious injury.

WARNING

LIVE ELECTRICAL COMPONENTS! During installation, testing, servicing, and troubleshooting of this product, it may be necessary to work with live electrical components. Failure to follow all electrical safety precautions when exposed to live electrical components could result in death or serious injury.

CAUTION

SAFETY HAZARD! Sharp Edge Hazard. Be careful of sharp edges on equipment or any cuts made on sheet metal while installing or servicing. Personal injury may result.

Section 2. General Information

This electric heater accessory is designed to provide power directly to the air handler from the accessory heater's power supply, eliminating the need for additional circuits. The power and control wiring each use a single wire harness to connect the heater and the air handler.

1. Check the unit heater label to confirm that the selected heater is approved for use with the air handler in the installed configuration. For some heaters, a corresponding secondary nameplate label is included. Place the label within the heater data table on the air handler nameplate.
2. Check the components received for damage. Report any defects or shortages to the transportation company immediately.
3. Be sure the power supply matches the listing shown on the heater nameplate.

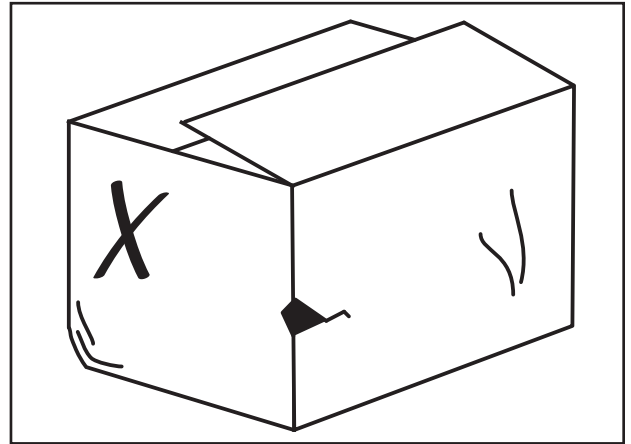

Section 3. Heater Assembly Labeled

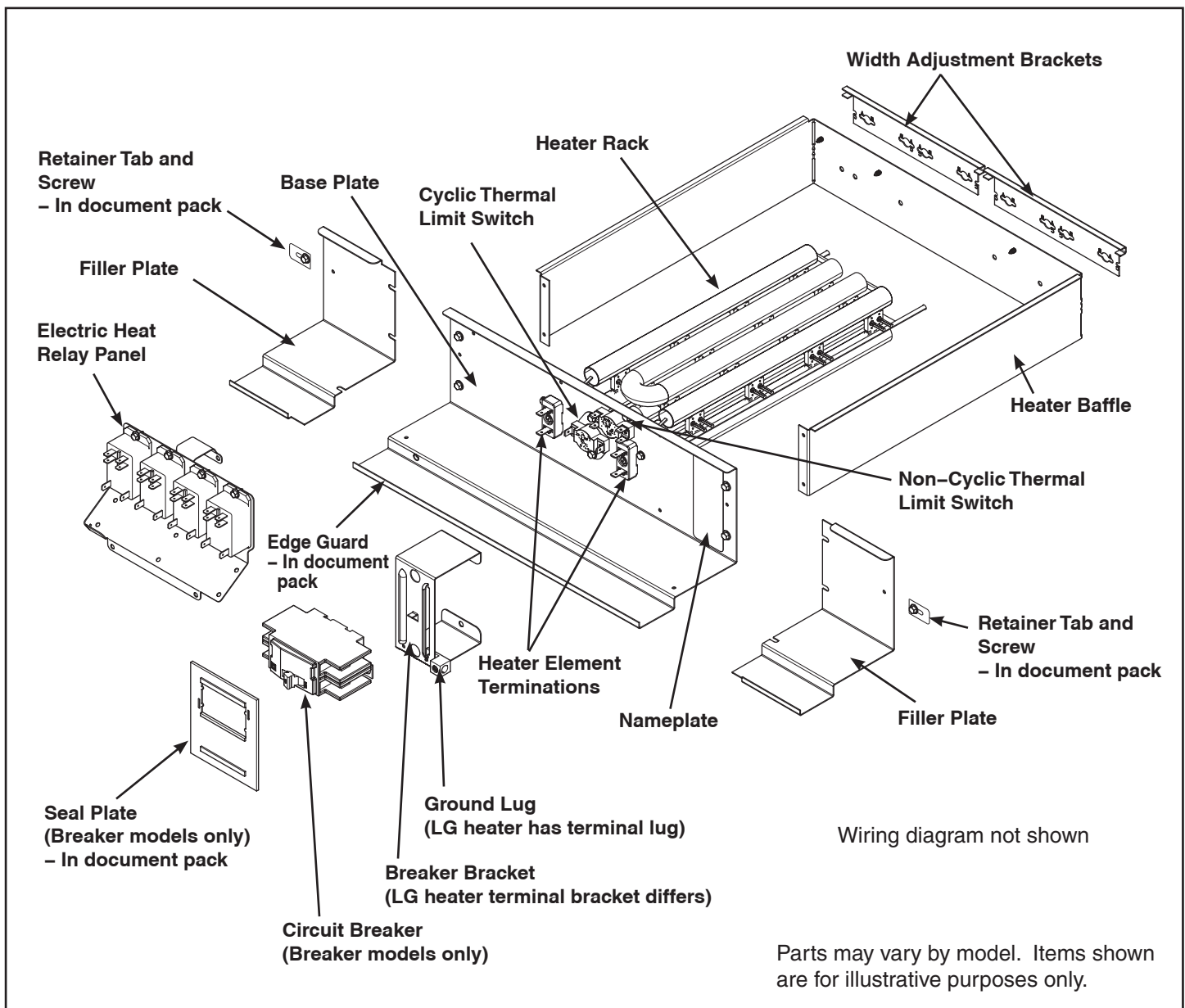

Section 4. Heater Selection

Determine which heater best fits your application needs. In addition to electrical considerations, you must know your cabinet size and the range of heaters which fit that cabinet.

4.1 Air Handler Model Number Matrix

Step 1 - Measure your cabinet and use the Air Handler Model Number Matrix to determine your cabinet size.

Air Handler Model Number Matrix															
Digit	1	2	3	4	5	6	7	8	9	10	11	12	13	14	15
Example	G	A	M	5	A	0	B	3	6	M	3	1	S	A	A
Brand	G														
Product Type	Air Handler	A													
Convertibility	Multi-poise 4-way		M												
Product Tier	Multi-speed			5											
Major Design Modifications	Letter Sequence				A										
No Descriptor	Air Handler / Coil					0									
Size (Footprint)	17.5 x 21.5						A								
	21.0 x 21.5						B								
	23.5 x 21.5						C								
Cooling Size: Air Handler	AH Coil - 1,000 BTU's (18, 24, 30, 36, 42, 48, 60)							0-9	0-9						
Electric Heat Input	Electric Heat - kW (05, 08, 10, 15, 20, 25)							0-9	0-9						
Airflow Type & Capability	M - Mid Effy, Multi-speed, 1-5 - nom. Tonnage (cfm/ton)									M	1-5				
Power Supply	208-230/1/60											1			
System Control Type	Standard - 24 VAC												S		
Minor Design Modifications	Letter Sequence													A	
Unit Parts Identifier	Letter Sequence														A

The cabinet size in this example is **B**.

Record Your Cabinet Size = _____

This matrix is provided as an example only.

Step 2 - Use the Heater Model Number Matrix to determine which heaters will fit in your cabinet and to determine if you will have to modify the heater to fit the cabinet.

		Electric Heat Model Number															
		Digit	1	2	3	4	5	6	7	8	9	10	11	12	13	14	15
Example		B	A	Y	E	A	A	C	1	5	B	K	1	A	A	A	
Brand	Both Brands	B															
Product Type	Accessory		A	Y													
Heat Type	Electric Heater				E												
Product Tier	Air Handler Tier (2,4 and 5)					A											
Size (Footprint)	Minimum Cabinet Width (A,B,C)							A									
	Maximum Cabinet Width (A,B,C)								C								
Electric Heat Input	Electric Heat - kW (04, 05, 08, 10, 15, 20, 25)									0-9	0-9						
Connection	Breaker											B	K				
	Lugs											L	G				
Power Supply	208-230/1/60														1		
	200/1/50														A		
	208-230/3/60														3		
Major Design Modifications	Letter Sequence														A		
Minor Design Modifications	Letter Sequence															A	
Unit Parts Identifier	Letter Sequence																A

The heater in this example will fit into cabinets A, B, & C.
From Step 1 we know that the heater needs to be sized to fit in a B cabinet.

See Section 5 for instructions for modifying your heater to fit various cabinet sizes.

Record Your Heater Size = _____

This matrix is provided as an example only.

Section 5. Adjust Heater

STEP 1 – Position Width Adjustment Brackets.

Two Width Adjustment Brackets are located at the back of the heater assembly. The heater comes sized for the smallest cabinet it will fit in. For this example our heater fits cabinets A, B, and C. It came sized for an A cabinet and we are sizing it for a B cabinet.

1. Loosen the screws that hold the Width Adjustment Brackets to the back of the heater.
2. Reposition each Width Adjustment Bracket until the correct holes line up with the loosened screws as illustrated in this step.
3. Tighten screws to hold Width Adjustment Bracket securely in place.

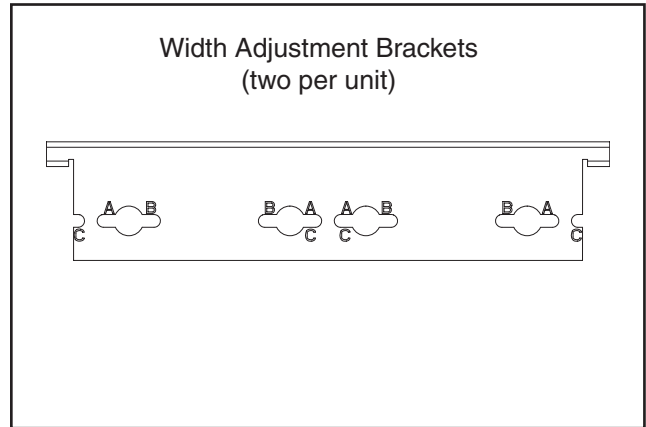

Cabinet A

The heater comes from the factory sized for cabinet A. No modifications to the Width Adjustment Brackets are required.

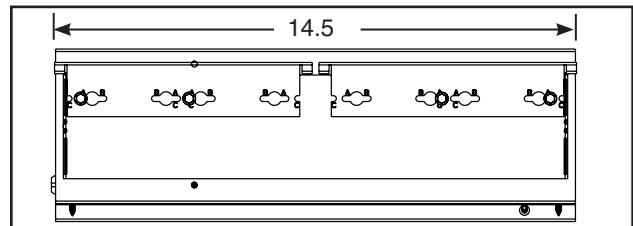

Cabinet B

Prepare the heater for cabinet B by modifying the Width Adjustment Brackets to align with the holes labeled B.

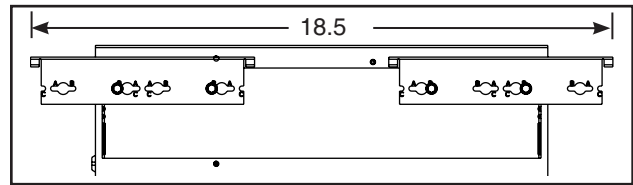

Cabinet C

Prepare the heater for cabinet C by modifying the Width Adjustment Brackets to align with the holes labeled C.

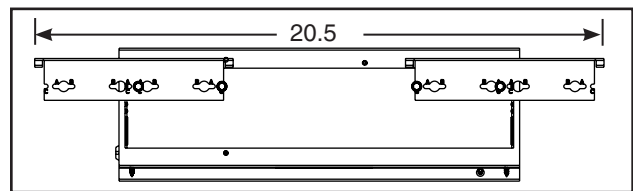

STEP 2 – Adjust Filler Plates.

Cabinet A

NOTE: No Filler Plates are required for the A cabinet.

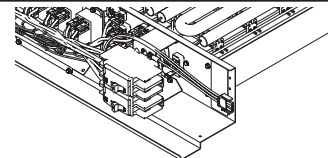

Cabinet B or C

1. Loosen the Filler Plate screws on each side of Base Plate (four total).
2. Slide in the correct Filler Plate on each side. Filler Plates are marked for the cabinet size they match with, for example, the Filler Plate for cabinet B is marked "B-CAB".
3. Tighten the Filler Plate screws loosened previously and add a screw (provided) to the bottom of each plate to hold Filler Plates in place.

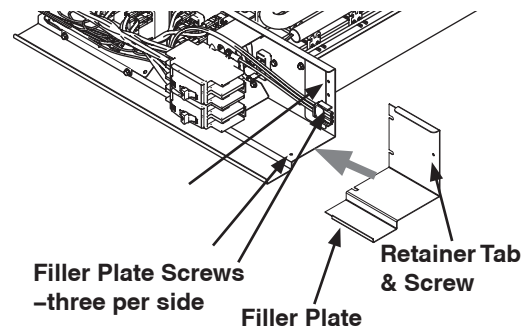

STEP 3 – Attach Retainer Tabs and Edge Guard

Note: For A cabinet widths, only the right side retainer tab must be installed.

1. Add the Retainer tabs using the screws provided (both tabs and screws are located in the documentation packet).

Leave the screws slightly loose so that the tab can slide to the left or right as needed. The tab will be used later to engage in a slot within the air handler cabinet.

Note: If no filler plates are needed, the retainer tabs must be attached to the heater coil flange. Leave the screws slightly loose so they can be slid to the left or right as needed.

2. The edge guard is located in the document pack. Cut the edge guard to the length needed for the heater width, including the filler plates.
3. Install the edge guard on the front of the heater flange as shown.

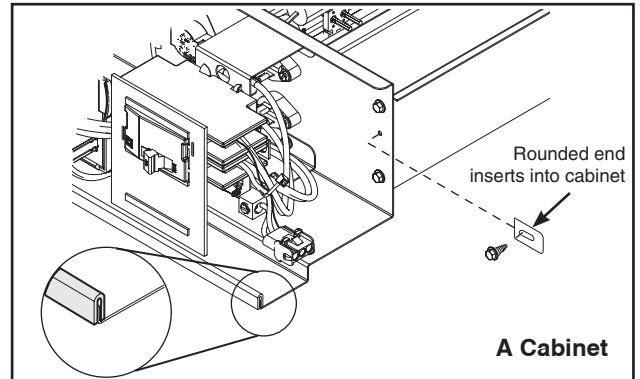
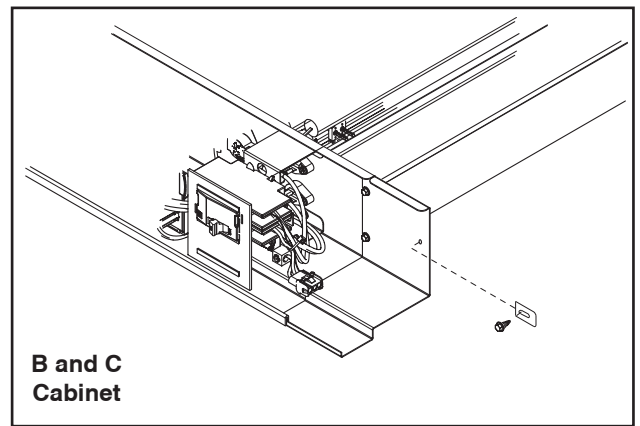

STEP 4 - (Optional) Rotate Circuit Breaker Assembly.

Note: For LG (lug) heater models the terminal block bracket does not rotate.

The need to reorient the Circuit Breaker Assembly depends upon the orientation of your application and which of the high voltage electrical conduit entry points you use for high voltage wiring.

Important: For air handler units installed in the horizontal right position, the circuit breakers on the heater must be rotated in order to comply with National Electric Code (NEC Section 240.81). The NEC requires that circuit breakers operated vertically must be oriented so that the "on" position of the breaker is upward.

⚠ CAUTION

SAFETY HAZARD! Sharp Edge Hazard. Be careful of sharp edges on equipment or any cuts made on sheet metal while installing or servicing. Personal injury may result.

1. Unscrew the Breaker Bracket from the Base Plate using a magnetic 1/4" hex driver with an extension. The extension allows for easier access to the screws which are located at the back of the bracket.
2. Rotate the bracket with circuit breaker(s) 180 °.
3. Use the screws removed in action 2 (above) to secure the bracket to the Base Plate.

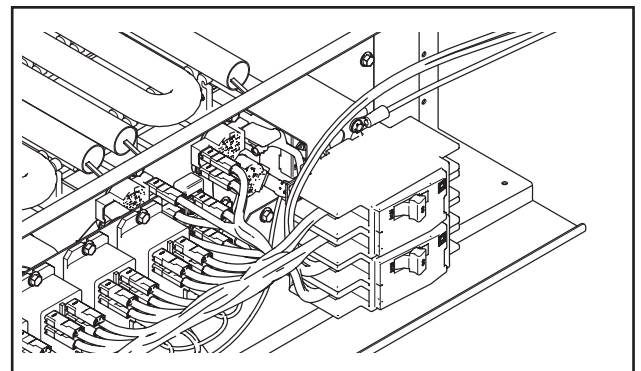
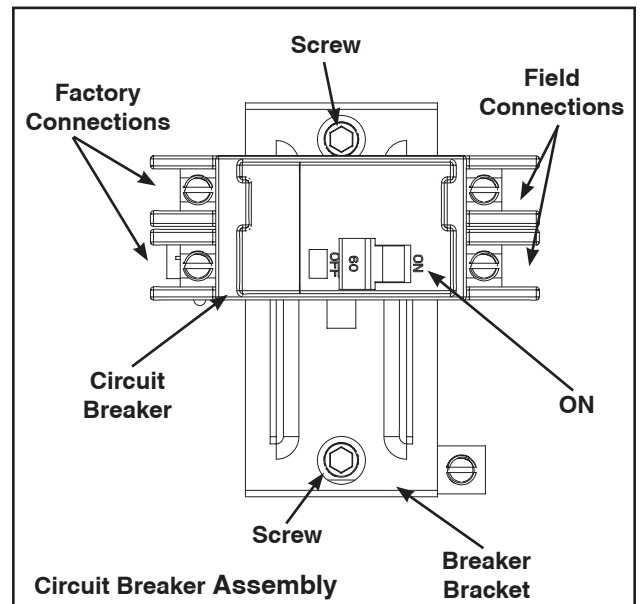

Section 6. Install Heater

STEP 1 - Remove Heater Compartment Panel.

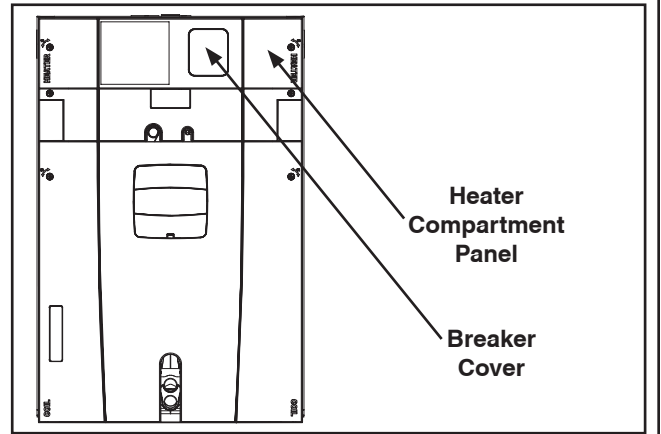

STEP 2 - Disconnect & Dispose of Pigtail Harness.

1. Unscrew the wire tie that is holding the pigtail harness to the cabinet.
2. Unplug and dispose of pigtail harness.

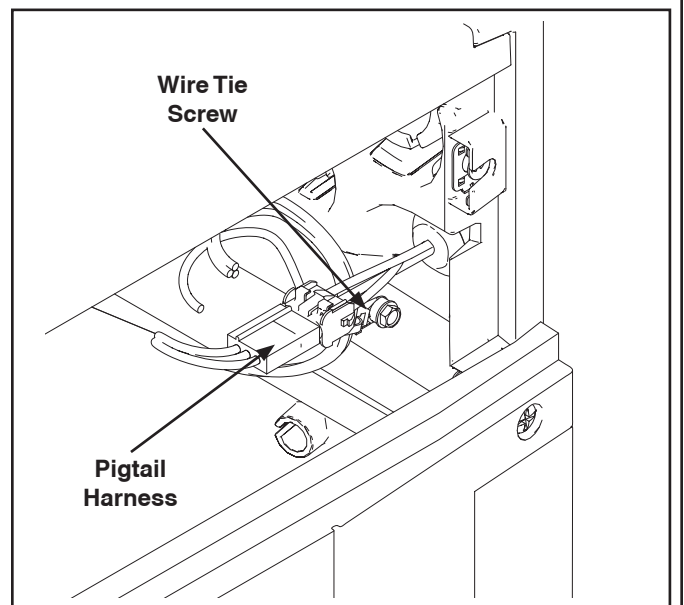

STEP 3 - Insert heater assembly into heater compartment.

1. Move factory wiring out of the way and into the grooves provided in cabinet.
2. Slide heater into heater compartment of air handler.

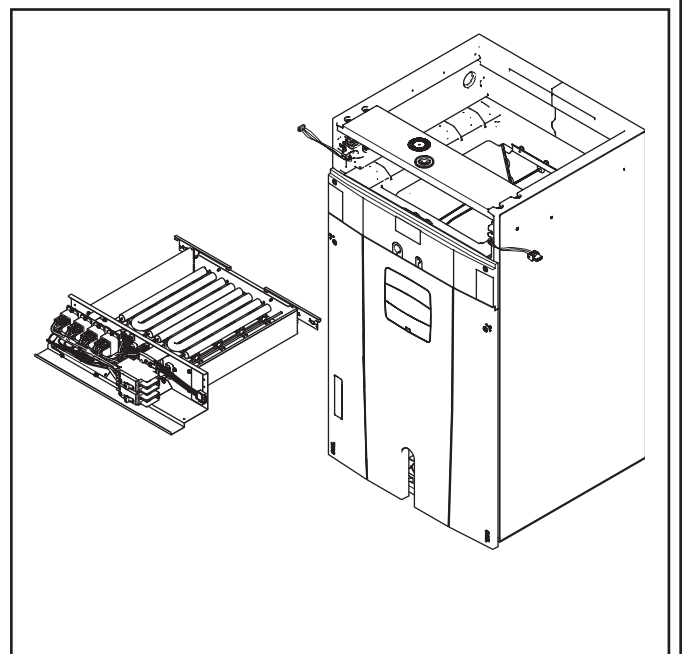

STEP – 4 Lock Retainer tabs.

Note: Retainer tabs are used to secure the heater inside of the heater compartment.

1. Slide retainer tab into recess in air handler cabinet.
2. Tighten screws to hold tab securely.
3. Repeat actions to secure the other tab.

Note: For A cabinet widths, only the right side retainer tab must be installed.

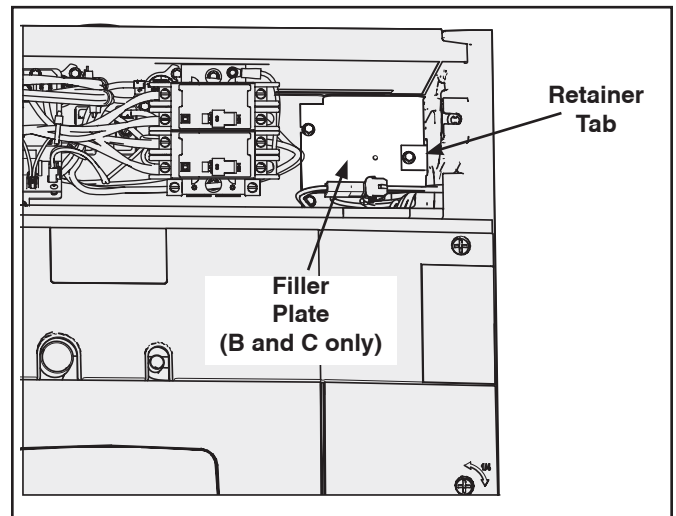

Route High Voltage wiring to unit.

STEP 5 - Select a conduit entry point. Drill a hole for the desired conduit size on units without a plug. A locating target is identified on these units.

Note: Some models may have a pre-molded conduit connection with plug. If a connection hole is already present, remove the plug from the entry point and use as is.

1. Select the entry point you will use to bring in your high voltage wiring.
2. Remove plug from the entry point.

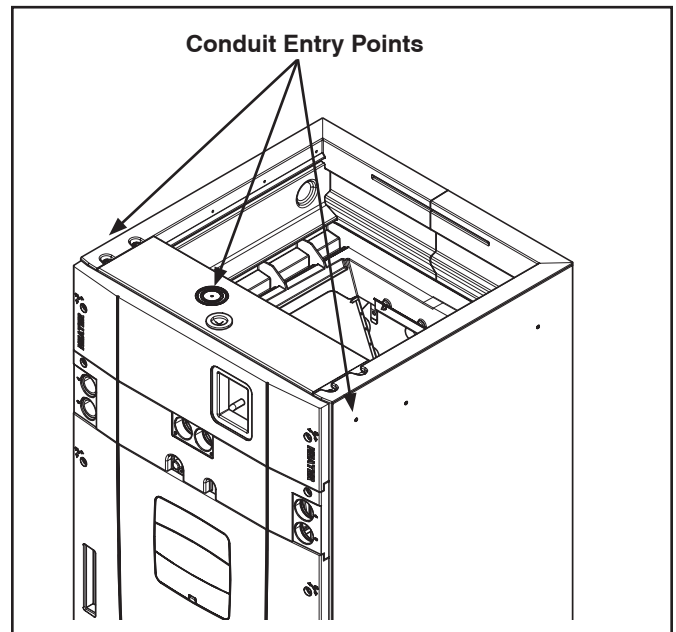

STEP 6 - Route conduit, if used, and wiring to the entry point and connect.

1. Use one hand to secure the factory supplied conduit nut from the inside of heater compartment.
2. Connect field supplied 3/4" or 1-1/2" conduit to conduit nut.

Note: Reducing bushings may be required for your application.

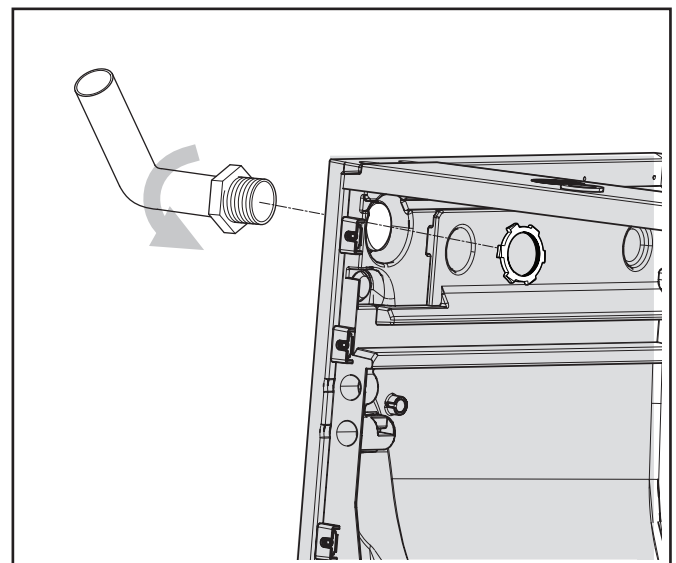

INSTALLER'S GUIDE

STEP 8 – Connect high voltage wiring

1. Connect the wiring to the lugs on the breaker models or to the terminal block on the lug models as illustrated.
2. Connect the ground wire to the ground lug.
3. Connect the 3-pin plug on the heater to the 3-pin plug in the air handler case.

Note: Minimum terminal screw torque is 45 in-lbs.

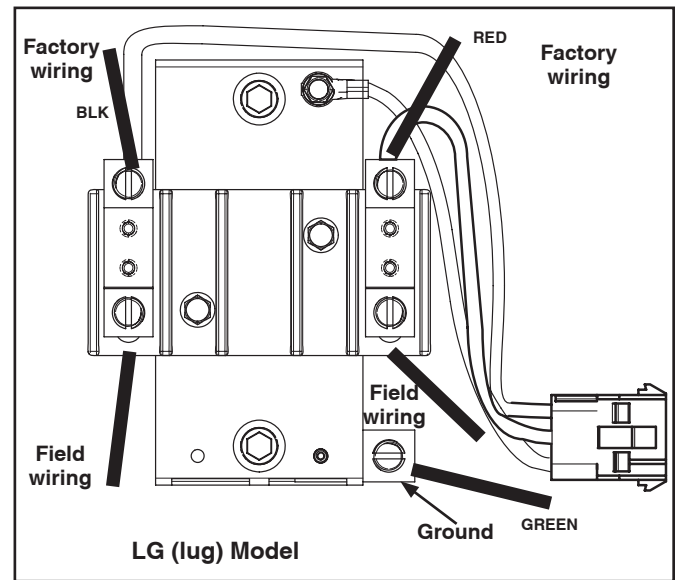
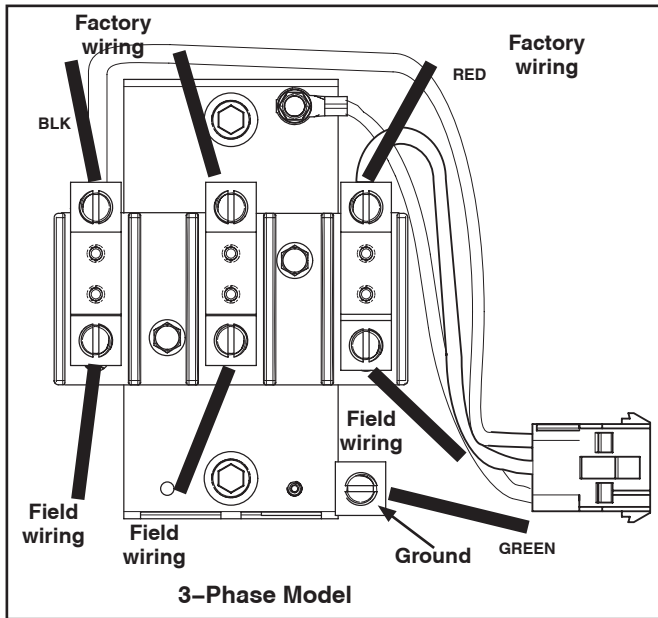
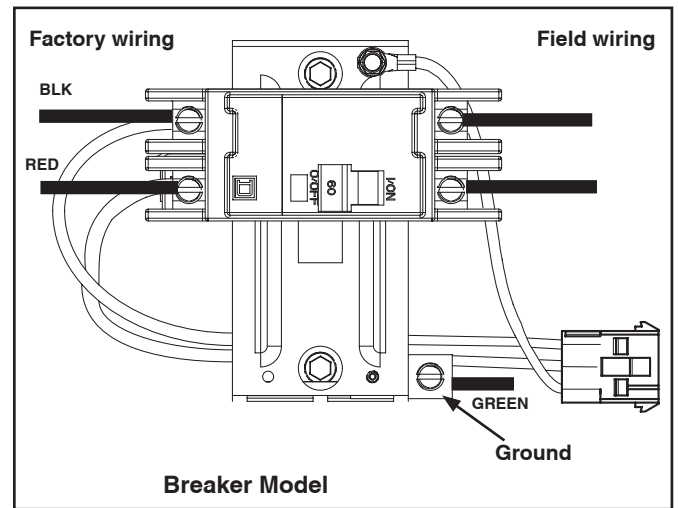

STEP 9 – Install the seal plate. Breaker models only.

1. Place the seal plate over the breaker so the tab on the right side is in place.
2. Snap on the left side of the seal plate that has the slot by the tab.

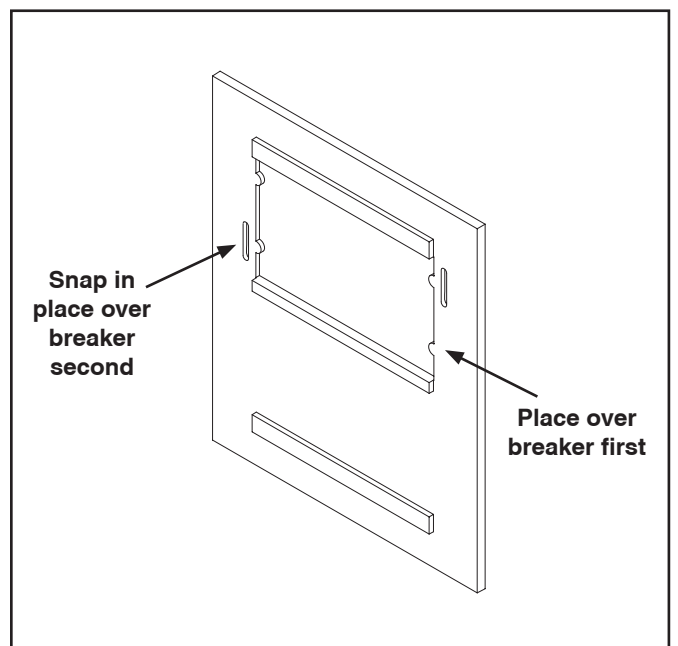

STEP 10 – Connect low voltage wiring.

1. Connect the 4-pin low voltage harness to Electric Heat Control as shown.
2. If installing in TAMX Air Handler models, connect the 2-pin resistor ID assembly (tie wrapped to Electric Heat Controls harness) into the 2-pin heater ID harness as shown.
3. All other Air Handler models, the 2-pin resistor ID assembly is not used and should be left disconnected.

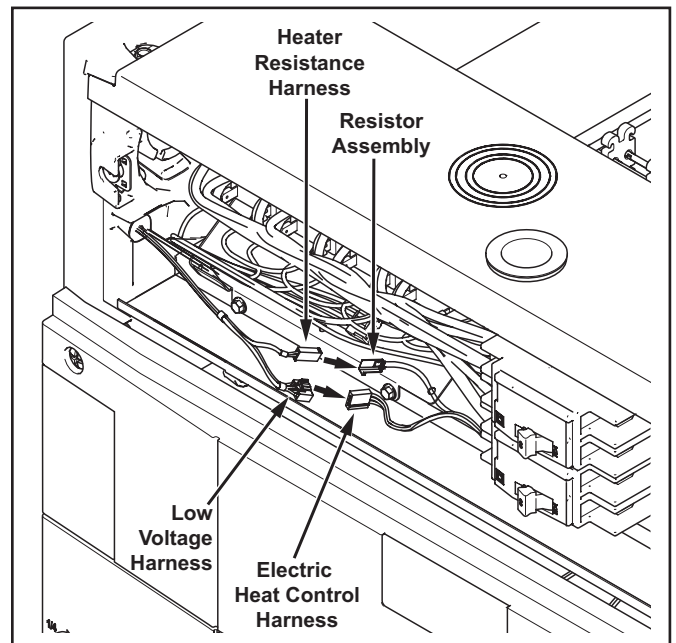

STEP 11 – Place Wiring Diagram.

1. Attach the wiring diagram, included in the documentation packet, to the back of the heater compartment panel.

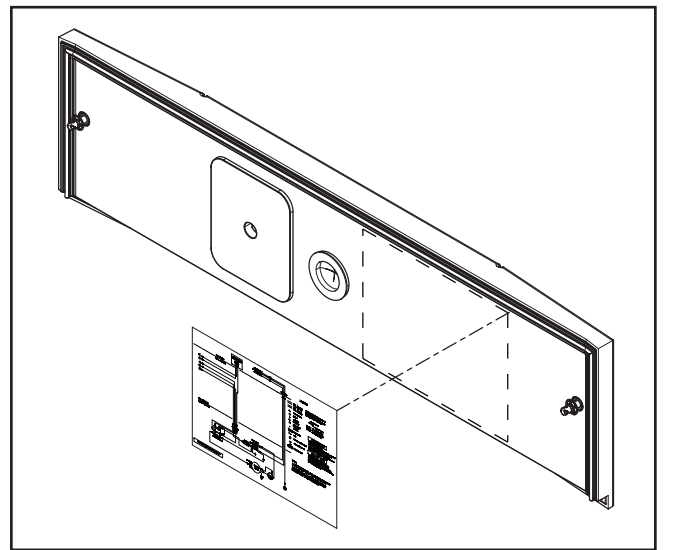

Note: Breaker models only.

STEP 12 – Remove breaker cover.

1. Remove 5/16 hex screw on back of breaker cover.
2. Remove and discard the two piece breaker cover from the heater compartment panel.

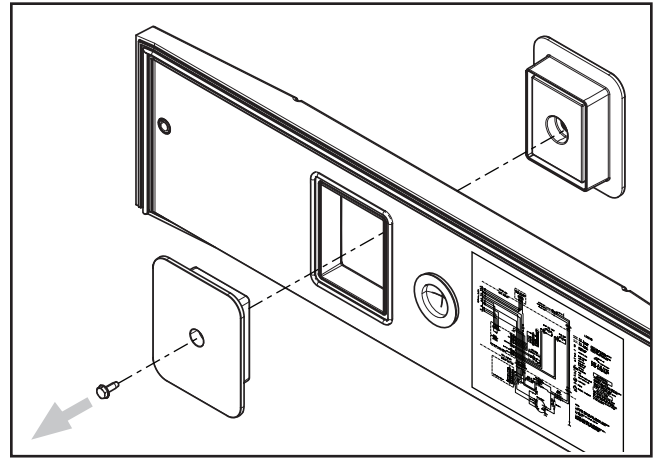

STEP 13 – Replace Heater compartment panel on air handler.

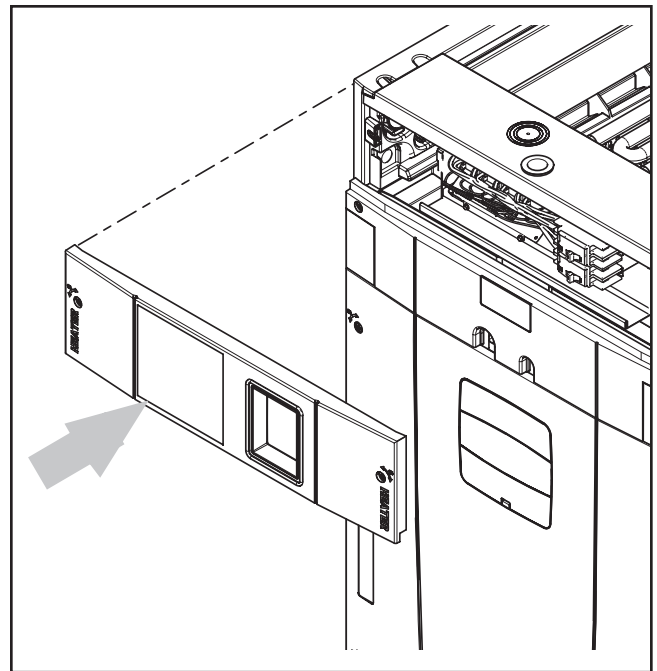

STEP 14 – For the TAM9 and TAMGB only, set the heater size in the Configuration Menu.

Note: For TAMX units, the heater size will be automatically configured by the AHC if the resistor ID assembly plug (see Step 10) is installed. The airflow level (Low, Med, High) will still need to be set in the Tech App.

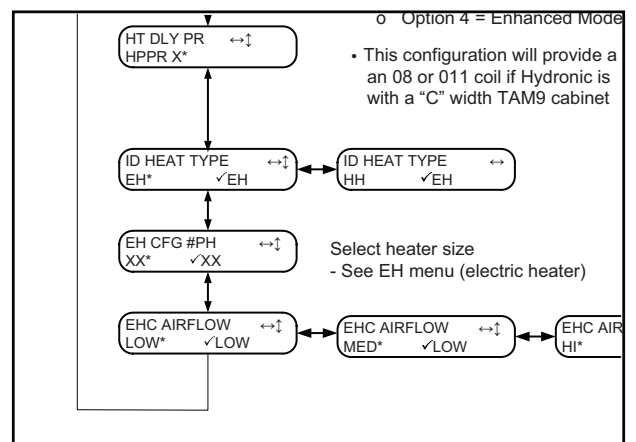

Make heater connections per hookup diagrams.

Heater Field Wiring

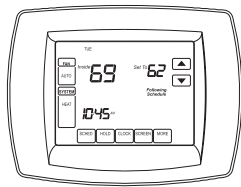

Comfort Control

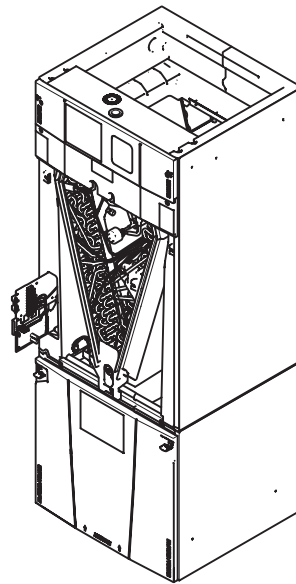

Air Handler

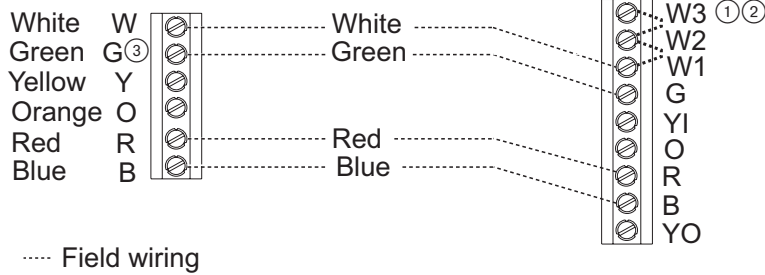

Notes:

- ① For multiple stages of electric heat, jumper W1, W2, and W3 together if comfort control has only one stage of heat.
 - ② 3 phase heaters require that the AFC board be configured for 3-phase heat.
 - ③ Thermostat G signal must be configured to bring fan on with electric heat.
- Reference the air handler Installer's Guide for details on low voltage wiring.

Section 7. Tables

Important: The BAYEA* electric heat accessory may include up to a combination of three 60 amp circuit breakers to provide an electrical disconnect for service personnel that is intended to help protect internal electrical components in the event of a short circuit or ground fault. As designed, the circuit breakers supplied in the BAYEA* accessory **DO NOT** provide overcurrent protection of the branch circuit. Therefore, the branch circuit(s) shall be sized and protected according to the unit nameplate.

Heater Model No.	Number of Circuits	240 VOLT			208 VOLT		
		Capacity		Heater Amps per Circuit	Capacity		Heater Amps per Circuit
		kW	BTUH		kW	BTUH	
BAYEAAC04BK1	1	3.84	13100	16.0	2.88	9800	13.8
BAYEAAC04LG1	1	3.84	13100	16.0	2.88	9800	13.8
BAYEAAC05BK1	1	4.80	16400	20	3.60	12300	17.3
BAYEAAC05LG1	1	4.80	16400	20	3.60	12300	17.3
BAYEAAC08BK1	1	7.68	26200	32	5.76	19700	27.7
BAYEAAC08LG1	1	7.68	26200	32	5.76	19700	27.7
BAYEAAC10BK1	1	9.60	32800	40	7.20	24600	34.6
BAYEAAC10LG1	1	9.60	32800	40	7.20	24600	34.6
BAYEAAC10LG3	1-3 PH	9.60	32800	23.1	7.20	24600	20
BAYEABC15BK1	2	14.40	49200	40/20	10.80	36900	34.6/17.3
BAYEABC15LG3	1-3 PH	14.40	49200	34.6	10.80	36900	30
BAYEABC20BK1	2	19.20	65600	40/40	14.40	49200	34.6/34.6

NOTE: See air handler Service Facts or Product Data for additional information on circuit ampacity.

Table 7.2 MINIMUM HEATER AIRFLOW CFM – HEATER MATRIX

MODEL NO.	BAYEAAC04BK1 BAYEAAC04LG1 BAYEAAC05BK1 BAYEAAC05LG1	BAYEAAC08BK1 BAYEAAC08LG1	BAYEAAC10BK1 BAYEAAC10LG1	BAYEAAC10LG3	BAYEABC15BK1	BAYEABC15LG3	BAYEABC20BK1
	W/O HP / WITH HP	W/O HP / WITH HP	W/O HP / WITH HP	W/O HP / WITH HP	W/O HP / WITH HP	W/O HP / WITH HP	W/O HP / WITH HP
TAM9A0A24V21D TAMXA0A24V21D TAMGB0A24V21D	638 / 713	638 / 900	675 / 900	600 / 713	--	--	--
TAM9A0B30V21D TAMXA0B30V31D	723 / 808	723 / 1020	765 / 1020	680 / 808	765 / 1063	850 / 1105	--
TAM9A0C36V31D TAMXA0C36V31D TAMGB0C36V31D	876 / 979	876 / 1236	927 / 1236	824 / 979	927 / 1288	1030 / 1339	--
TAM9A0C42V31D TAMXA0C42V41D	978 / 1093	978 / 1380	1035 / 1380	920 / 1093	1035 / 1438	1150 / 1495	1380 / 1610
TAM9A0C48V41D TAMXA0C48V41D TAMGB0C48V41D	1063 / 1188	1063 / 1500	1125 / 1500	1000 / 1188	1125 / 1563	1250 / 1625	1500 / 1750
TAM9A0C60V51D TAMXA0C60V51D TAMGB0C60V51D	1063 / 1188	1063 / 1500	1125 / 1500	1000 / 1188	1125 / 1563	1250 / 1625	1500 / 1750
GAM5B0A18M11E	TAP 3 / TAP 4	TAP 3 / TAP 4	TAP 3① / TAP 5①	TAP 5 / TAP 5②	--	--	--
GAM5B0A24M21E	TAP 3 / TAP 4	TAP 3 / TAP 4	TAP 3① / TAP 5①	TAP 5 / TAP 5②	--	--	--
GAM5B0B30M21E	TAP 2 / TAP 3	TAP 3 / TAP 4	TAP 3 / TAP 4	TAP 3③ / TAP 4③	TAP 4 / TAP 5	TAP 4 / TAP 5	--
GAM5B0B36M31E	TAP 2 / TAP 3	TAP 3 / TAP 4	TAP 4 / TAP 5	TAP 4 / TAP 5	TAP 4 / TAP 5	TAP 4 / TAP 5	--
GAM5B0C42M31E	TAP 2 / TAP 3	TAP 2 / TAP 3	TAP 2 / TAP 3	TAP 2 / TAP 3	TAP 3 / TAP 4	TAP 3 / TAP 4	--
GAM5B0C48M41E	TAP 2 / TAP 3	TAP 2 / TAP 3	TAP 2 / TAP 3	TAP 2 / TAP 3	TAP 3 / TAP 4	TAP 3 / TAP 4	TAP 3 / TAP 4
GAM5B0C60M51E	TAP 2 / TAP 3	TAP 2 / TAP 3	TAP 2 / TAP 3	TAP 2 / TAP 3	TAP 3 / TAP 4	TAP 3 / TAP 4	TAP 3 / TAP 4
TAM4A0A18S11E	TAP 1 / TAP 1	TAP 1 / TAP 2	TAP 2 / TAP 3	TAP 1 / TAP 3	--	--	--
TAM4A0A24S21E	TAP 1 / TAP 1	TAP 1 / TAP 1	TAP 1 / TAP 2④	TAP 1 / TAP 3	--	--	--
TAM4A0A30S21E	TAP 1 / TAP 1	TAP 1 / TAP 2	TAP 1 / TAP 2	TAP 1 / TAP 1	TAP 2 / TAP 3	TAP 1⑦ / TAP 3⑦	--
TAM4A0A36S31E	TAP 1 / TAP 1	TAP 2⑤ / TAP 2⑤	TAP 2⑥ / TAP 3⑥	TAP 1 / TAP 1	TAP 2 / TAP 3	TAP 1 / TAP 3	--
TAM4A0B42S31E	TAP 1 / TAP 1	TAP 1 / TAP 1	TAP 1 / TAP 1	TAP 1 / TAP 1	TAP 1 / TAP 1	TAP 1⑦ / TAP 3⑦	TAP 1 / TAP 3
TAM4A0C48S41E	TAP 1 / TAP 1	TAP 1 / TAP 1	TAP 1 / TAP 1	TAP 1③ / TAP 1③	TAP 1 / TAP 1	TAP 1 / TAP 1	TAP 1 / TAP 1
TAM4A0C60S51E	TAP 2 / TAP 2	TAP 2 / TAP 3	TAP 2 / TAP 3	TAP 1 / TAP 1	TAP 3 / TAP 4	TAP 1 / TAP 1	TAP 3 / TAP 4

SEE AIR HANDLER NAMEPLATE OR PRODUCT DATA FOR EXCEPTIONS

① Heater not qualified for downflow installations
 ② Approved for 240 V only
 ③ Heater not qualified for 208V in upflow installations
 ④ Min speed is Tap 3 is for horizontal left only
 ⑤ Heaters not qualified for horizontal left installations. Upflow installation approved for 240 Volts only.
 ⑥ Approved for 240 V only. Approved for upflow only.
 ⑦ Heater not qualified for 240V in downflow applications.
 Note: TAM9, TAMX and TAMGB models are variable speed.

BAYEA ELECTRIC HEAT STAGE MATRIX

Model No.	BAYEAAC04BK1* BAYEAAC04LG1*	BAYEAAC05BK1* BAYEAAC05LG1*	BAYEAAC08BK1* BAYEAAC08LG1*	BAYEAAC10BK1* BAYEAAC10LG1*	BAYEABC15BK1*	BAYEABC20BK1*	BAYEACC25BK1*	BAYEAAC10LG3*	BAYEABC15LG3*
Electric Heat Stages	1	1	2	2	3	3	3	1	1
Stage 1 Capacity (W1)(kW)	3.84	4.8	3.84	4.8	4.8	9.6	9.6	9.6	14.4
Stage 2 Capacity (W1+W2)(kW)	3.84	4.8	7.68	9.6	9.6	14.4	19.2	9.6	14.4
Stage 3 Capacity (W1+W2+W3)(kW)	3.84	4.8	7.68	9.6	14.4	19.2	24.0	9.6	14.4

Section 8. Heater Operation

8.1 GAM5B Heater Operation

Electric Heating

1. R-W contacts close on the comfort control sending 24VAC to the W terminal on the electronic fan relay. 24VAC is also sent to energize the heat relay.
2. R-G contacts close on the comfort control sending 24VAC to the G terminal on the electronic fan relay. (The combination of 24VAC on terminals W and G on the electronic fan relay will close the high speed contacts of the electronic fan relay)
3. WJ contacts on the electronic fan relay close providing an interlock circuit to allow the electric heat relays to operate.

The comfort control must be setup to control R-G contacts with a call for electric heat. This closes the interlock circuit and allows the heat relay circuit to be energized.

8.2 TAM4 Heater Operation

Electric Heating

1. R-W contacts close on the comfort control sending 24VAC to energize the heat relay.
2. R-G contacts close on comfort control sending 24VAC to the fan relay
3. Relay contacts 1 and 3 close
4. The blower will now run on the selected speed. Speed is field selectable
5. Contacts 4 & 6 on the fan relay close providing the interlock circuit to allow the electric heat relays to operate

The comfort control must be setup to control R-G contacts with a call for electric heat. This closes the interlock circuit and allows the heat relay circuit to be energized.

8.3 TAM9, TAMX / TAMGB Heater Operation

Electric Heating

Note: The TAM9, TAMX / TAMG can use a communicating or 24 volt comfort control to send a heater request to the AFC/AHC.

1. When a request for electric heat is received, the AFC/AHC will energize the on board 24 volt relays per the amount of heat requested from the thermostat and the size of the heater installed.
2. The AFC/AHC sends a command to the serial communicating blower motor to run proper airflow and close the blower interlock relay on the EHC.

About Trane and American Standard Heating and Air Conditioning

Trane and American Standard create comfortable, energy efficient indoor environments for residential applications. For more information, please visit www.trane.com or www.americanstandardair.com

The manufacturer has a policy of continuous data improvement and it reserves the right to change design and specifications without notice. We are committed to using environmentally conscious print practices.