

Installer's Guide

Convertible Air Handlers 1-1/2 – 5 Ton

Black Epoxy Coil

TAM4A0A18S11ED

TAM4A0A24S21ED

TAM4A0A30S21ED

TAM4A0A36S31ED

TAM4A0B42S31ED

TAM4A0C48S41ED

TAM4A0C60S51ED

Standard Coil

TAM4A0A18S11SD

TAM4A0A24S21SD

TAM4A0A30S21SD

TAM4A0A36S31SD

TAM4A0B42S31SD

TAM4A0C48S41SD

TAM4A0C60S51SD

ALL phases of this installation must comply with NATIONAL, STATE AND LOCAL CODES

Important: This Document is customer property and is to remain with this unit. Please return to service information pack upon completion of work.

Important: These instructions do not cover all variations in systems nor provide for every possible contingency to be met in connection with the installation. Should further information be desired or should particular problems arise which are not covered sufficiently for the purchaser's purposes, the matter should be referred to your installing dealer or local distributor.

Note: The manufacturer recommends installing ONLY AHRI approved, matched indoor and outdoor systems. Some of the benefits of installing approved matched indoor and outdoor split systems are maximum efficiency, optimum performance, and the best overall system reliability.

Note: All AHRI ratings use a 90 second fan off delay. Use your branded thermostat or separate relay to enable this delay.

Note: Condensation may occur on the surface of the air handler when installed in an unconditioned space. When units are installed in unconditioned spaces, verify that all electrical and refrigerant line penetrations on the air handler are sealed completely.

Important: TAM4A0C60S51 air handler applied in downflow or horizontal configurations should not exceed 2000 CFM. Airflow above 2000 CFM could result in water blow-off. For verification, see airflow table.

Important: The TAM4 air handlers will only use the following internal electric heaters:

BAYEAAC04BK1, BAYEAAC04LG1

BAYEAAC05BK1, BAYEAAC05LG1

BAYEAAC08BK1, BAYEAAC08LG1

BAYEAAC10BK1, BAYEAAC10LG1

BAYEAAC10LG3, BAYEABC15BK1

BAYEABC15LG3, BAYEABC20BK1

BAYEACC25BK1

Note: Representative illustrations only included in this document. Most illustrations display the upflow configuration.

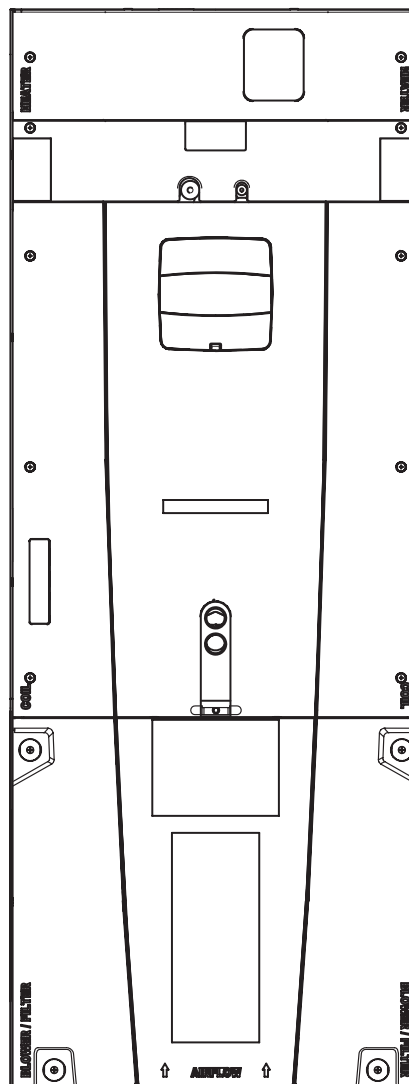

Table of Contents

Section 1. Safety Information	2
Section 2. Unit Design.....	3
Section 3. Unit Preparation.....	5
Section 4. Optional Cabinet Disassembly.....	6
Section 5. Place Unit at Location.....	11
Section 6. Unit Location Considerations.....	12
Section 7. Setting the Unit - Vertical Installation.....	17
Section 8. Setting the Unit - Horizontal Installation.....	19
Section 9. Connecting the Duct work.....	20
Section 10. Refrigerant Line.....	21
Section 11. Refrigerant Line Brazing.....	22
Section 12. Condensate Drain Piping.....	25
Section 13. Electrical - Low Voltage.....	27
Section 14. Electrical - High Voltage.....	30
Section 15. Filters.....	33
Section 16. Unit Outline Drawing.....	34
Section 17. Start Up.....	35
Section 18. Sequence of Operation.....	36
Section 19. Checkout Procedures.....	37

Section 1. Safety Information

⚠ WARNING

SAFETY HAZARD! This information is intended for use by individuals possessing adequate backgrounds of electrical and mechanical experience. Any attempt to repair a central air conditioning product may result in personal injury and/or property damage. The manufacturer or seller cannot be responsible for the interpretation of this information, nor can it assume any liability in connection with its use.

⚠ WARNING

LIVE ELECTRICAL COMPONENTS! During installation, testing, servicing, and troubleshooting of this product, it may be necessary to work with live electrical components. Failure to follow all electrical safety precautions when exposed to live electrical components could result in death or serious injury.

⚠ CAUTION

HAZARDOUS VAPORS! Do not install an air handler with a non-ducted return in the same closet, alcove, or utility room as a fossil fuel device. Hazardous vapors can be distributed throughout the conditioned space and equipment damage can result.

⚠ CAUTION

CORROSION HAZARD! To prevent shortening its service life, the air handler should not be used during the finishing phases of construction. The low return air temperatures can lead to the formation of condensate. Condensate in the presence of chlorides and fluorides from paint, varnish, stains, adhesives, cleaning compounds, and cement creates a corrosive condition which may cause rapid deterioration of the cabinet and internal components.

⚠ CAUTION

SAFETY HAZARD! Sharp Edge Hazard. Be careful of sharp edges on equipment or any cuts made on sheet metal while installing or servicing. Personal injury may result.

Important: Panel damage can occur with prolonged exposure to POE lubricants. Air handler front panels that come in contact with POE oil must be washed immediately with soapy water.

⚠ WARNING

This product can expose you to chemicals including lead, which are known to the State of California to cause cancer and birth defects or other reproductive harm. For more information go to www.P65Warnings.ca.gov.

Section 2. Unit Design

2.1 Cabinet Penetration

Important: Due to the unique design of this unit, which allows the electrical wiring to be routed within the insulation, do not screw, cut, or otherwise puncture the unit cabinet in any location other than the ones illustrated.

Important: Under no conditions should metal strapping be attached to the unit to be used as support mechanisms for carrying or suspension purposes.

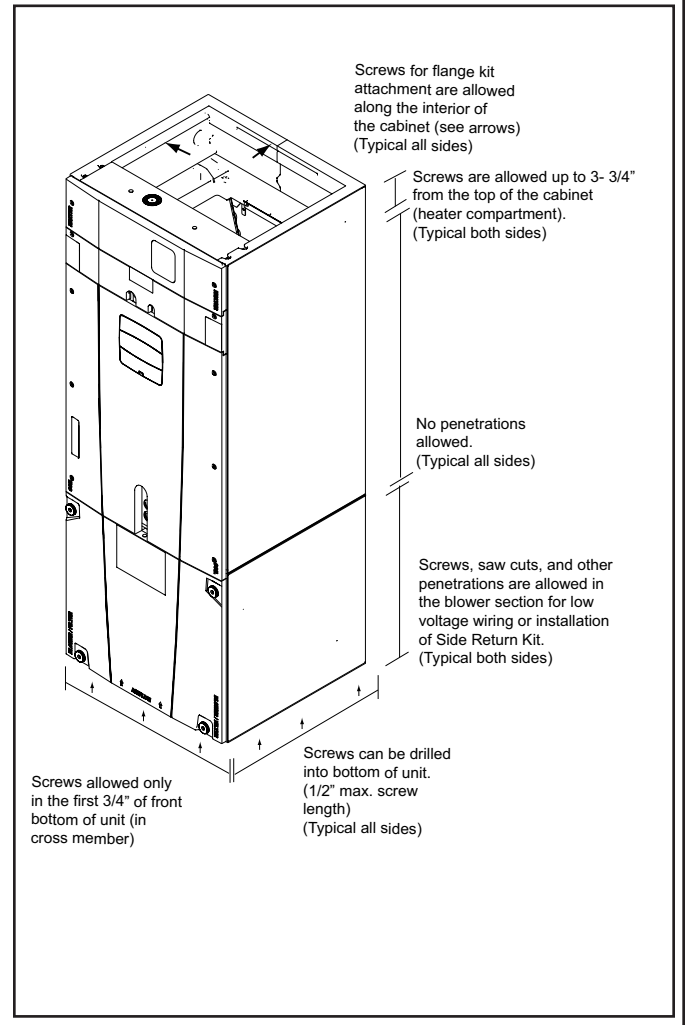

2.2 Panel Removal

The unit contains four (4) access panels: Blower/Filter, Coil, Line Set, and Heater.

The Blower/Filter panel is removed using thumb screws.

1. Turn thumb screws on Blower/Filter panel.
2. Pull top of panel out, away from cabinet.
3. Lift panel up out of channel.
4. Set aside.

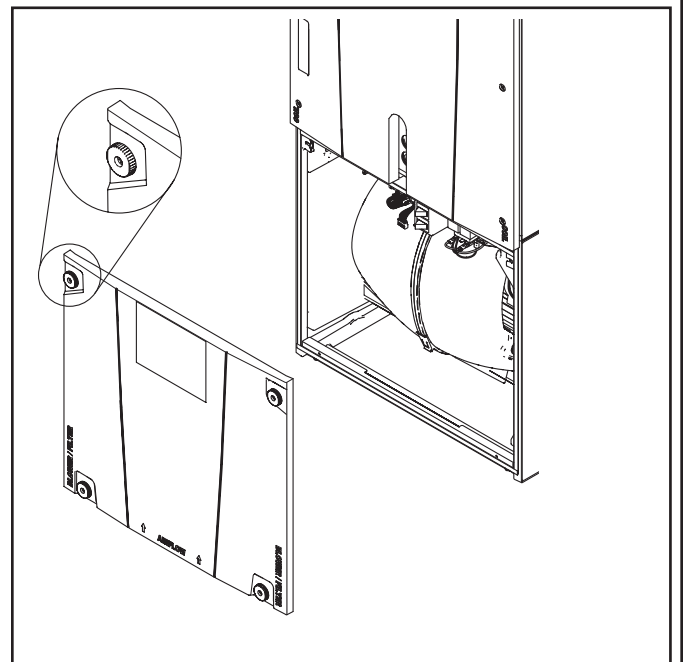

The Coil, Line Set, and Heater panels are removed using Phillips head screws.

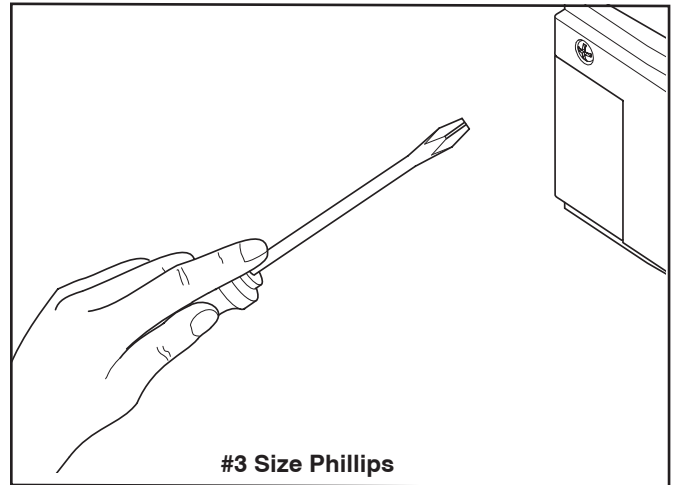

Coil and Heater panels must be removed prior to removing the Line Set panel.

To remove Coil Panel:

1. Turn screws on Coil panel.
2. Pull top of panel out, away from cabinet.
3. Pull panel up and out of channel.
4. Set aside.

To remove Heater Panel:

1. Turn screws on Heater panel.
2. Pull panel straight out, away from cabinet.
3. Set aside.

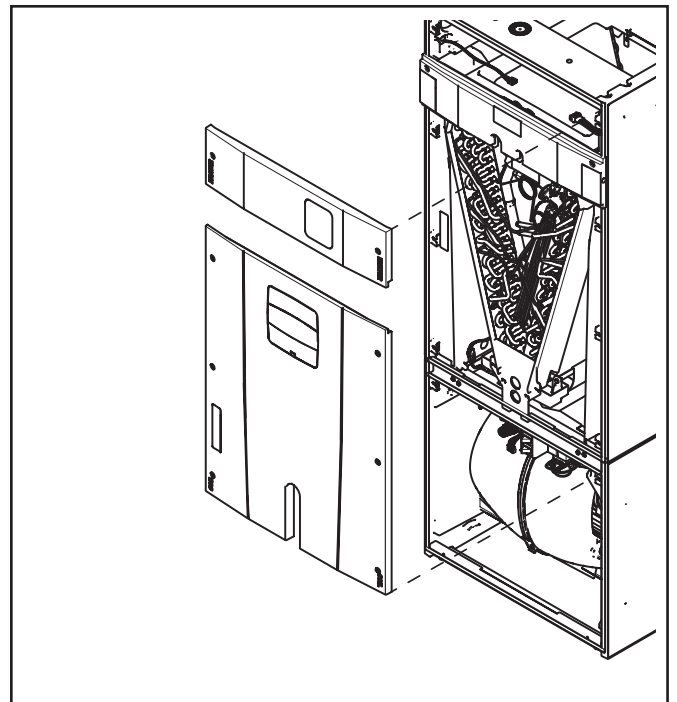

Removal of the Line Set panel is required for all refrigerant line brazing and some condensate line assembly depending on your orientation.

To remove Line Set panel:

1. Remove both Heater and Coil panels.
2. Turn screws on Line Set Panel.
2. Pull panel straight out, away from cabinet.
3. Set aside.

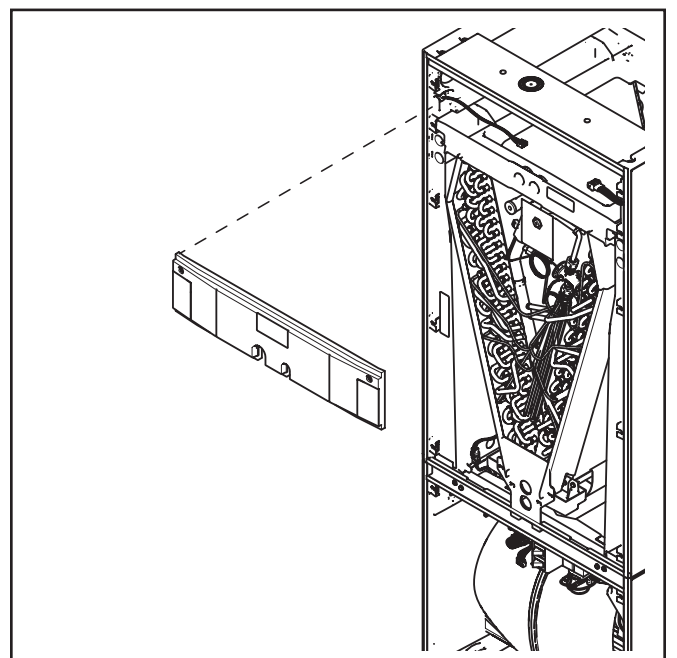

NOTE: After replacing all panels, loosen the Line Set Panel screws approximately 1/4 - 1/2 turn. This will improve the seal between the Heater Panel and Line Set Panel.

Section 3. Unit Preparation

3.1 Prepare The Unit For Installation

STEP 1 - Check for damage and report promptly to the carrier any damage found to the unit.

Note: If the unit must be transported in a horizontal position, it must be laid on its back (marked "REAR" on carton).

Note: After the unit is removed from the carton, release pressure from the coil to verify coil is pressurized and leak free.

Note: Remove the cardboard from the bottom of the blower. Cut the tie wrap and remove the foam block located at the motor.

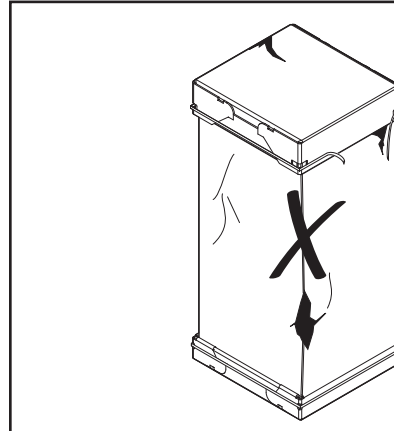

Table 3.2 Unit Accessories

Accessory Number	Description	Fits Cabinet Size
BAYEAC04BK1	Electric Heater, 4kW, Breaker, 24V Control, 1 Ph	A to C
BAYEAC04LG1	Electric Heater, 4kW, Lugs, 24V Control, 1 Ph	A to C
BAYEAC05BK1	Electric Heater, 5kW, Breaker, 24V Control, 1 Ph	A to C
BAYEAC05LG1	Electric Heater, 5kW, Lugs, 24V Control, 1 Ph	A to C
BAYEAC08BK1	Electric Heater, 8kW, Breaker, 24V Control, 1 Ph	A to C
BAYEAC08LG1	Electric Heater, 8kW, Lugs, 24V Control, 1 Ph	A to C
BAYEAC10BK1	Electric Heater, 10kW, Breaker, 24V Control, 1 Ph	A to C
BAYEAC10LG1	Electric Heater, 10kW, Lugs, 24V Control, 1 Ph	A to C
BAYEAC10LG3	Electric Heater, 10kW, Lugs, 24V Control, 3 Ph	A to C
BAYEABC15BK1	Electric Heater, 15kW, Breaker, 24V Control, 1 Ph	B to C
BAYEABC15LG3	Electric Heater, 15kW, Lugs, 24V Control, 3 Ph	B to C
BAYEABC20BK1	Electric Heater, 20kW, Breaker, 24V Control, 1 Ph	B to C
BAYEACC25BK1	Electric Heater, 25kW, Breaker, 24V Control, 1 Ph	C
BAYSUPFLGAA	Supply Duct Flange A	A
BAYSUPFLGBA	Supply Duct Flange B	B
BAYSUPFLGCA	Supply Duct Flange C	C
BAYRETFLGAA	Return Duct Flange A	A
BAYRETFLGBA	Return Duct Flange B	B
BAYRETFLGCA	Return Duct Flange C	C
BAYSRKIT100A	Side Return Kit	A to C
BAYFLR1620A	High Velocity Filter Kit, 16" X 20" X 1" (10 filters)	A
BAYFLR2020A	High Velocity Filter Kit, 20" X 20" X 1" (10 filters)	B
BAYFLR2220A	High Velocity Filter Kit, 22" X 20" X 1" (10 filters)	C
TASB175SB	Plenum Stand with Integrated Sound Baffle A	A
TASB215SB	Plenum Stand with Integrated Sound Baffle B	B
TASB235SB	Plenum Stand with Integrated Sound Baffle C	C
MITISRKIT1620	Side Return Kit with 16" x 20" Filter	A to C
BAYFRKIT175	Front Return Kit for 17.5" Cabinet	A
BAYFRKIT210	Front Return Kit for 21.0" Cabinet	B
BAYFRKIT235	Front Return Kit for 23.5" Cabinet	C
BAYBAFKT175	Sound Baffle Kit for 17.5" Cabinet	A
BAYBAFKT210	Sound Baffle Kit for 21.0" Cabinet	B
BAYBAFKT235	Sound Baffle Kit for 23.5" Cabinet	C
TASSBK175	Sound Baffle Kit for 17.5" Cabinet	A
TASSBK215	Sound Baffle Kit for 21.0" Cabinet	B
TASSBK235	Sound Baffle Kit for 23.5" Cabinet	C
BAYICKSKIT01A	Internal Condensate Switch Kit	A to C
BAYHHKIT001A	Horizontal Hanger Kit	A to C
BAYUVCLK001A	UVC Lights	A to C
BAYLVKIT100A	Low Voltage Conduit Entry Kit	A to C
BAYSPEKT200A	Single Point Power Entry Kit	B to C
BAYINSKT175A	Solcoustic® Liner Kit - 17.5" Cabinet	A
BAYINSKT215A	Solcoustic® Liner Kit - 21.5" Cabinet	B
BAYINSKT235A	Solcoustic® Liner Kit - 23.5" Cabinet	C
BAYCNDPIP01A	3/4" PVC Threaded Pipe Kit Foam Seal (10 per box)	A to C

Section 4. Optional Cabinet Disassembly

4.1 Disassemble cabinet for installation in tight areas or as needed.

Note: If the unit must be transported in a horizontal position, it must be laid on its back (marked "REAR" on carton).

Note: To reassemble cabinet, follow the steps in reverse order. Ensure electrical connections are secure and the plug clips are engaged.

STEP 1 - Remove all four front panels. See Section 2.2.

STEP 2 - Remove the two screws on the seal bar and pull the seal bar straight out.

STEP 3 - Disconnect all wiring connections routed to the blower assembly.

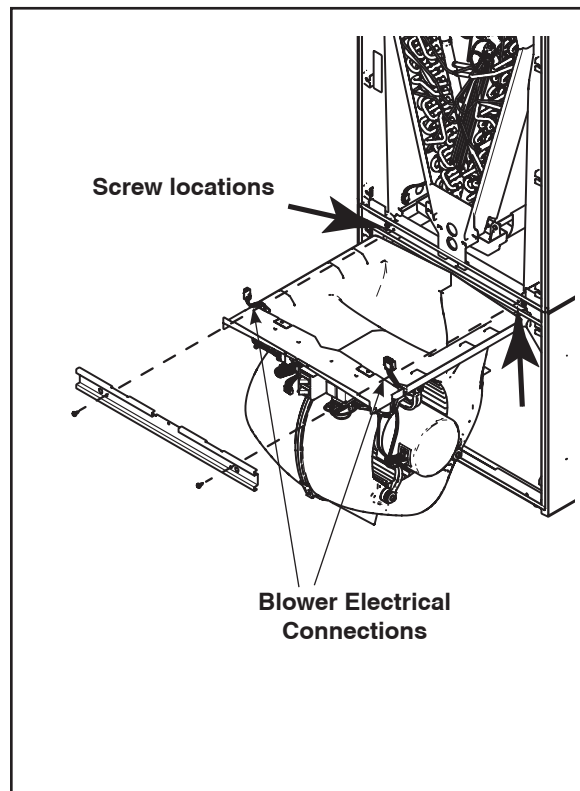

STEP 4 - Slide Blower assembly out of unit using built-in blower support channels and set aside.

Note: Remove the cardboard from the bottom of the blower. Cut the tie wrap and remove the foam block located at the motor.

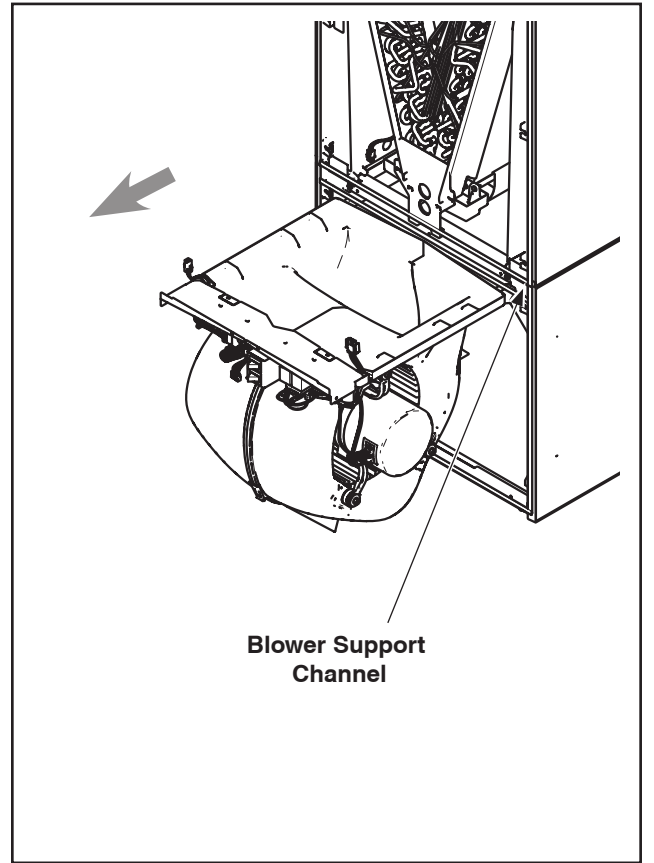

**Blower Support
Channel**

STEP 5 - Disconnect wires to the EEV motor and sensors inside the coil assembly. Cut the wire ties on those wire harnesses.

Note: If cut, wire ties that held the sensor must be replaced after the coil is placed back into the cabinet.

STEP 6 - Slide Coil assembly out of unit using built-in coil support channels and set aside.

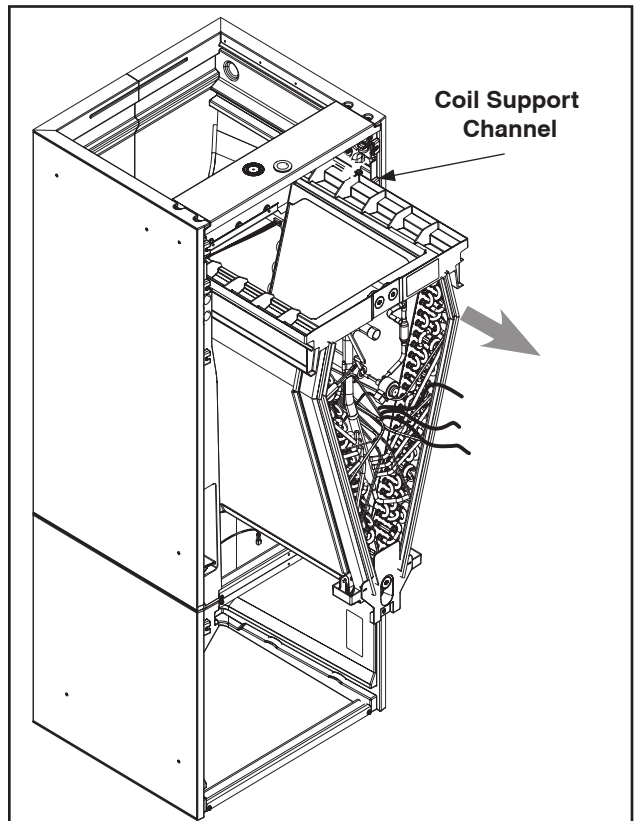

STEP 7 - Use a 5/16 Allen wrench on the locking mechanism on each side of the bottom half of the cabinet to loosen the locking mechanism. The locks loosen by turning counter-clockwise approximately 3/4 of a turn.

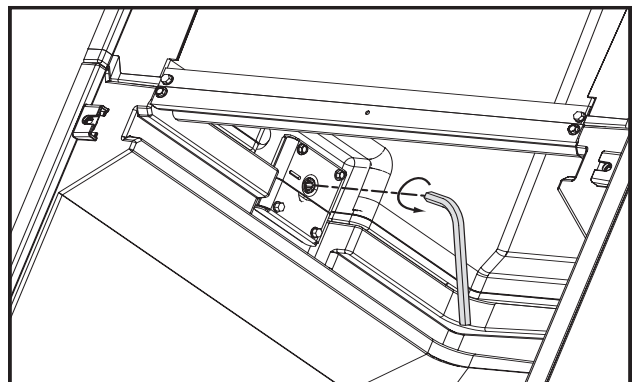

STEP 8 - Lift the Coil section up and away from the Blower section. Set aside.

Note: When separating the two cabinet pieces, make sure the gasket remains intact.

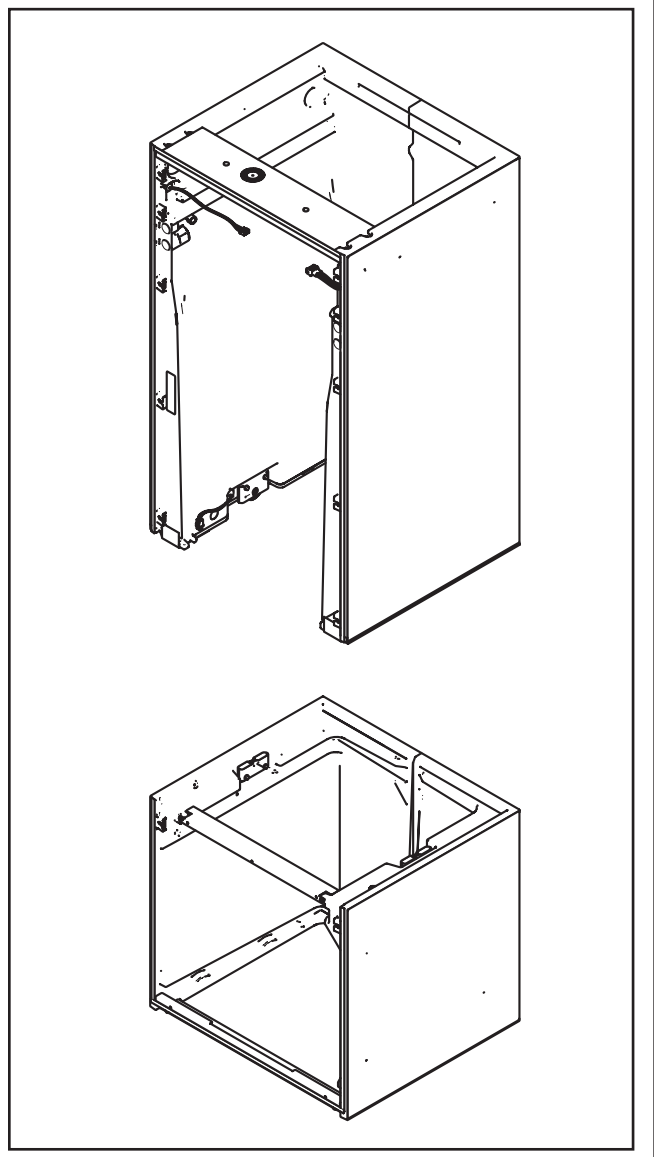

STEP 9 - For extremely tight spaces where the cabinet needs to be rotated through a small opening, remove the top panel. Use a manual driver to avoid stripping screw holes.

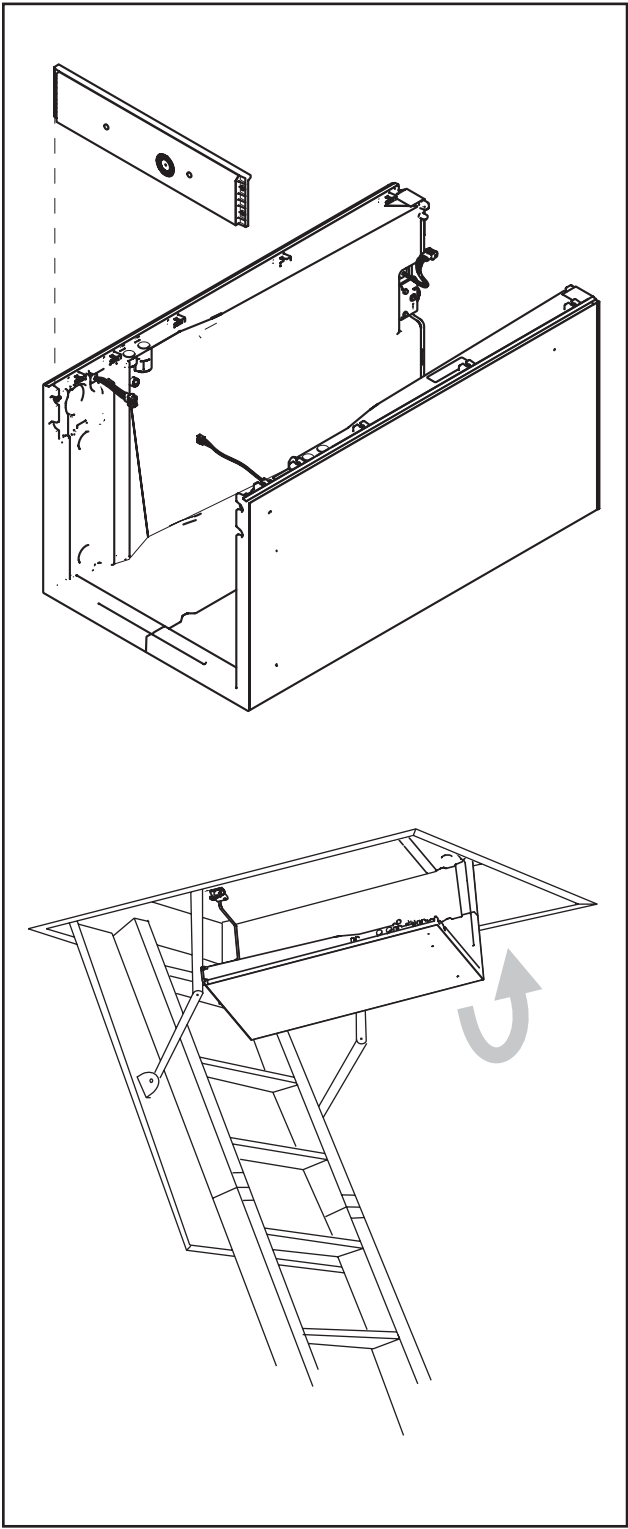

STEP 10 - Continue preparation by following the proper carrying procedures shown in Section 5.

Section 5. Place Unit at Location

5.1 Carry Unit

STEP 1 - Carry the unit to the installation location.

STEP 2 - Reassemble by reversing the steps listed in Section 4 if disassembly was required.

Important: Under no conditions should metal strapping be attached to the unit to be used as support mechanisms for carrying or suspension purposes.

Approved carrying:

1. Hold by the cross members within the cabinet or unit top plate and use as handles for lifting and carrying the coil and blower sections.

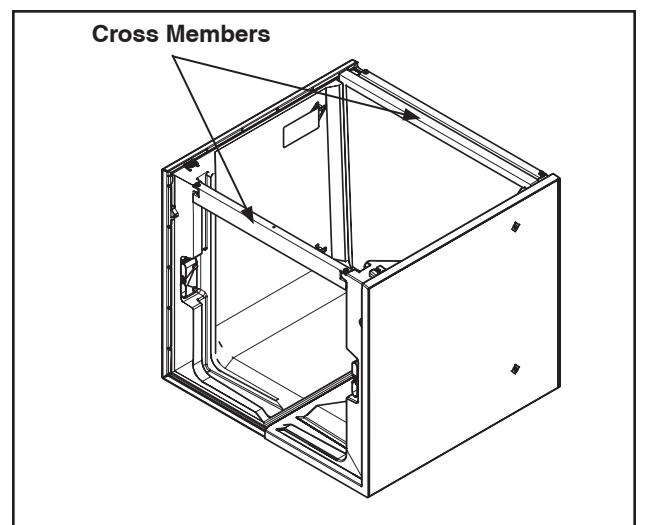
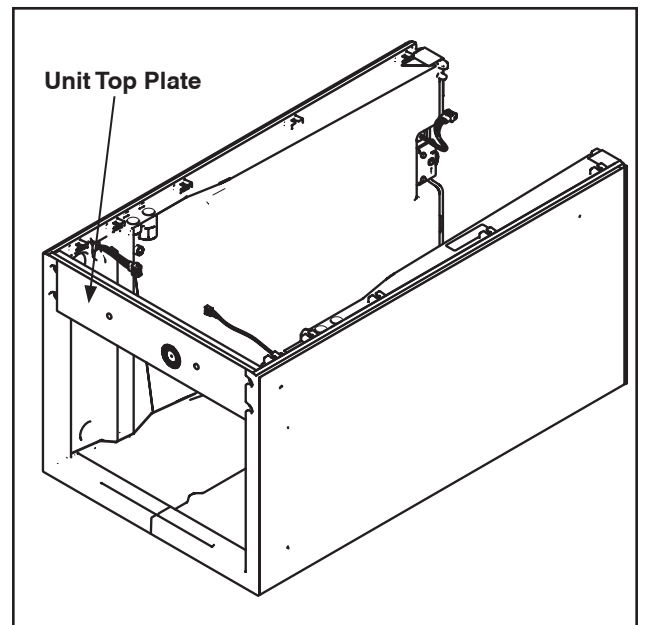
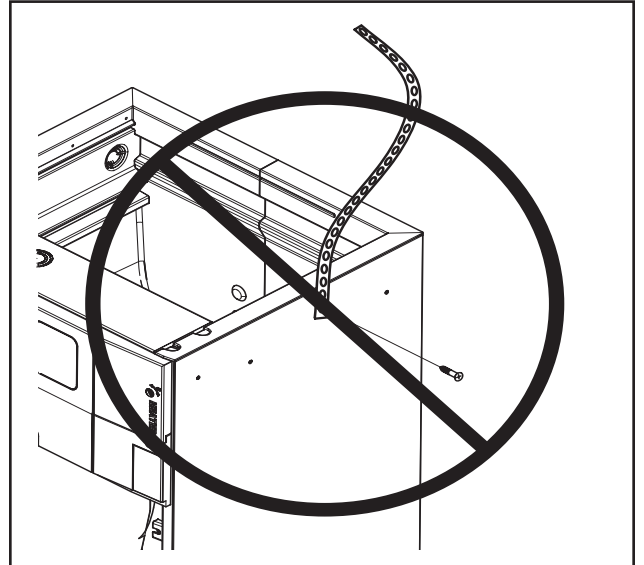

Section 6. Unit Location Considerations

6.1 Unit Dimensions and Weight

Table 7.1

Model Number	H x W x D in.	**Blower Compartment in.	Unit Net Weight lbs.
TAM4A0A18S11ED TAM4A0A18S11SD	49.9 x 17.5 x 21.8	22	113
TAM4A0A24S21ED TAM4A0A24S21SD	49.9 x 17.5 x 21.8	22	116
TAM4A0A30S21ED TAM4A0A30S21SD	49.9 x 17.5 x 21.8	22	117
TAM4A0A36S31ED TAM4A0A36S31SD	49.9 x 17.5 x 21.8	22	120
TAM4A0B42S31ED TAM4A0B42S31SD	55.7 x 21.3 x 21.8	22	133
TAM4A0C48S41ED TAM4A0C48S41SD	56.9 x 23.5 x 21.8	22	143
TAM4A0C60S51ED TAM4A0C60S51SD	61.7 x 23.5 x 21.8	22	160
** Subtract from total height to get Coil and Heater compartment height.			

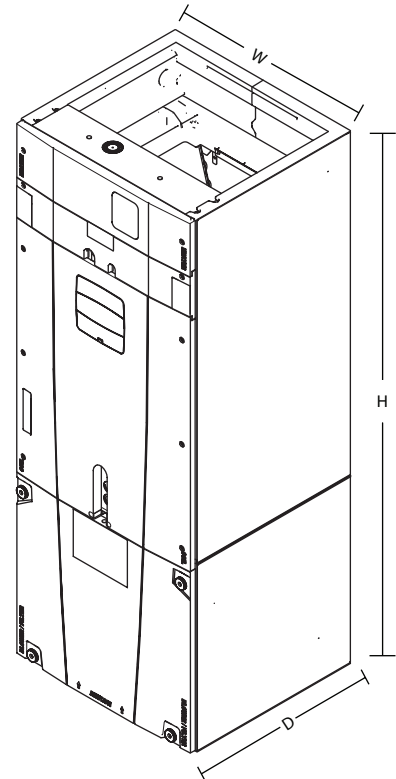

6.2 Four-Way Conversion

To place the unit in the configuration your application requires (upflow, downflow, horizontal right, or horizontal left), simply turn the unit to that orientation.

Note: The air handlers are shipped from the factory suitable for four-way application.

Note: Entry for low voltage connections is allowed on either side of cabinet.

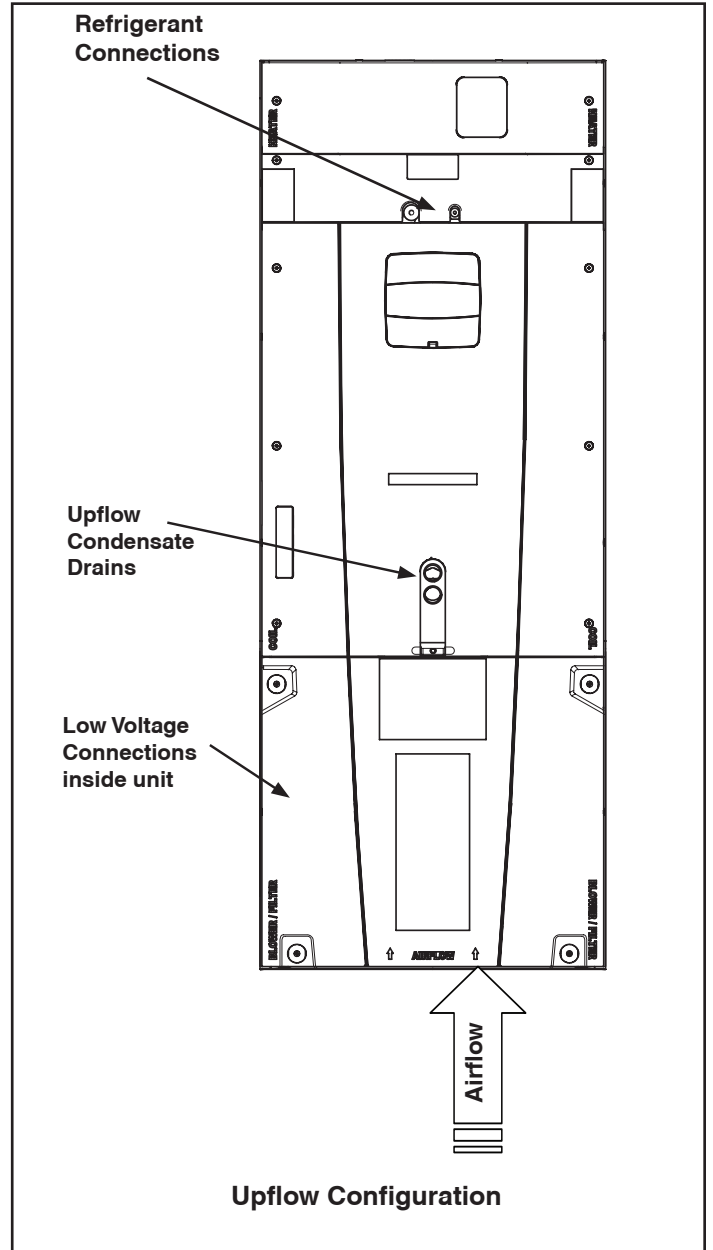
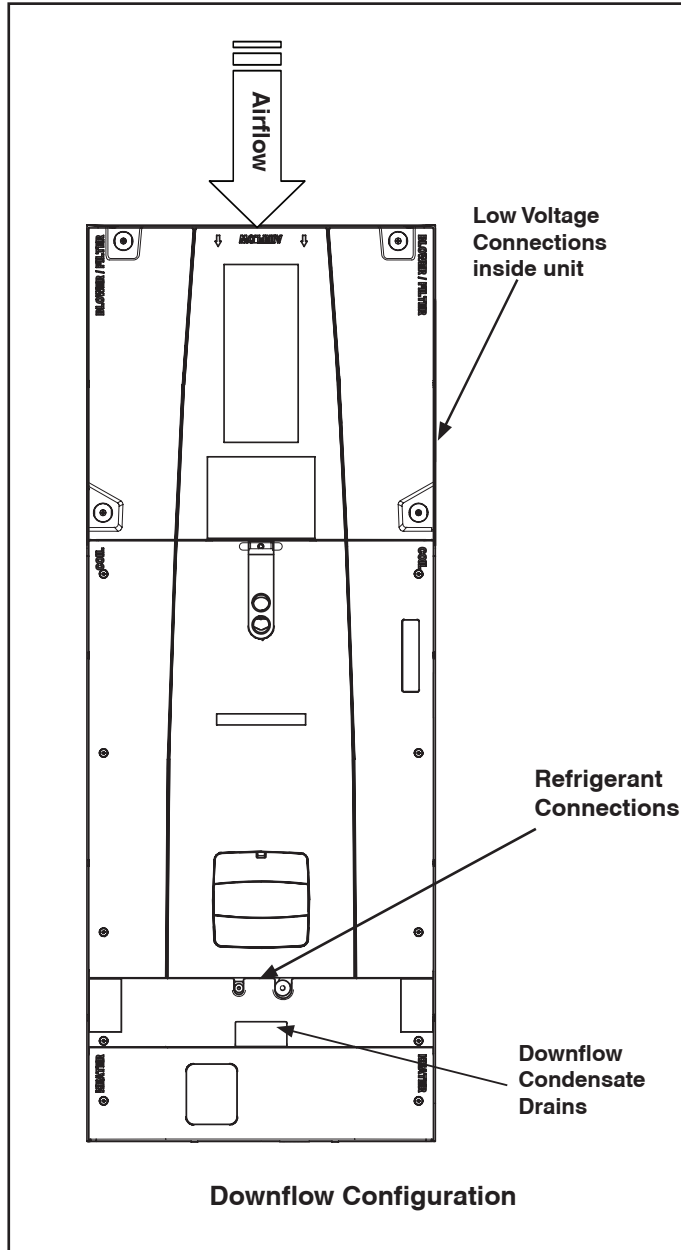

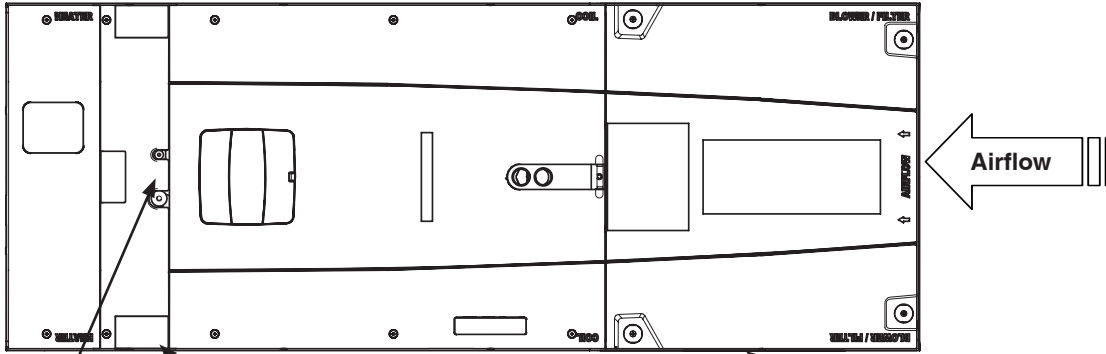

Refrigerant Connections

Horizontal Left Condensate Drains

Low Voltage Connections inside unit

Horizontal Left Configuration

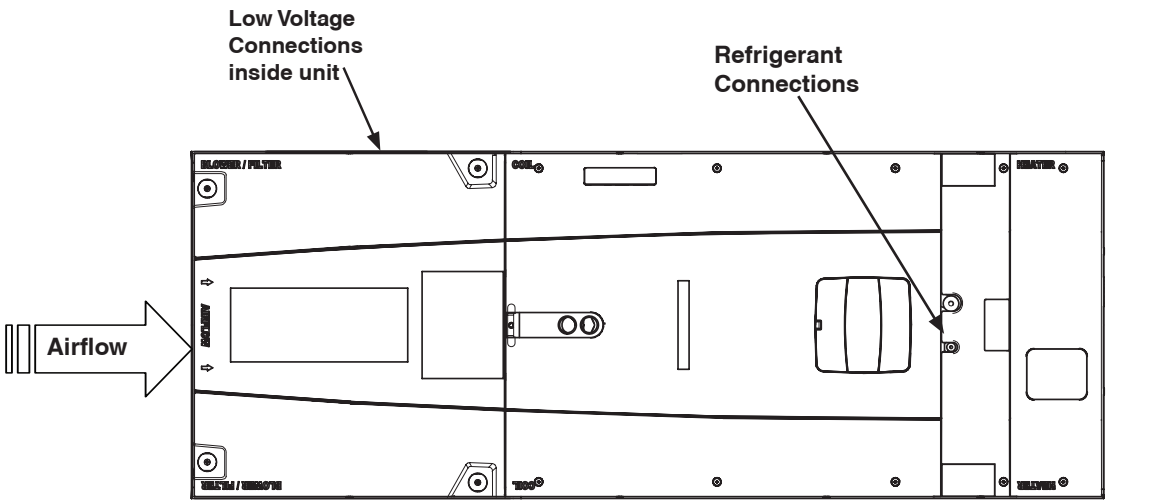

Low Voltage Connections inside unit

Refrigerant Connections

Horizontal Right Condensate Drains

Horizontal Right Configuration

6.3 Non Ducted Applications

⚠ CAUTION

HAZARDOUS VAPORS! Do not install an air handler with a non-ducted return in the same closet, alcove, or utility room as a fossil fuel device. Hazardous vapors can be distributed throughout the conditioned space and equipment damage can result.

Non-Ducted Return Installations:

- Installation in a closet, an alcove, or a utility room without a return duct requires the use of a plenum accessory kit as it uses the area space as a return air plenum. Minimum clearances to combustible materials and service access must be observed (see outline drawing).
- This area may also be used for other purposes, including an electric hot water heater, but in no case shall a fossil fuel device be installed and/or operated in the same closet, alcove, or utility room.
- Review local codes to determine limitations if the unit is installed without a return air duct.

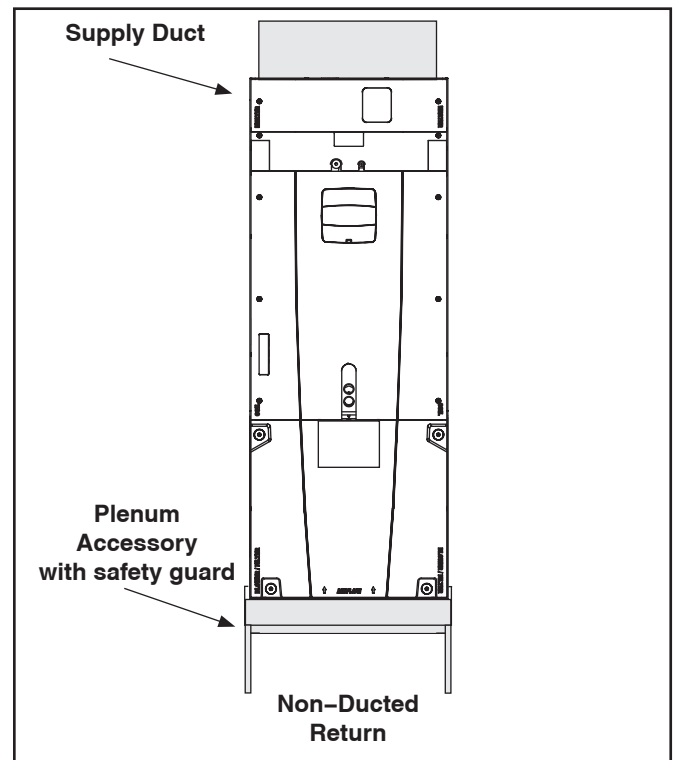

6.4 Ducted Applications

Ducted Return Installations:

- Installation in an attic, garage, or crawl space with ducted supply and return air is appropriate. Minimum clearances to combustible materials and service access must be observed (see outline drawing).

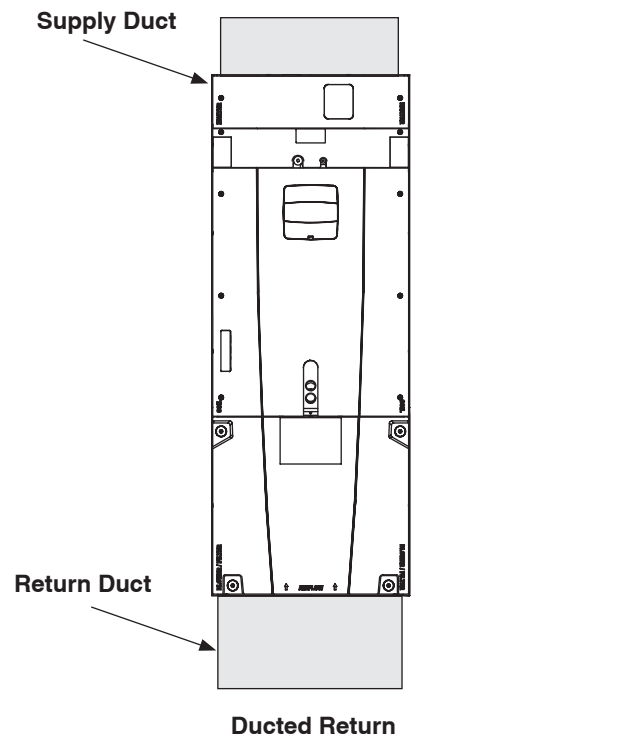

6.5 Additional Unit Preparation Considerations

For proper installation the following items must be considered prior to moving the unit to its installation site:

- **Important:** *When the air handler is located adjacent to the living area, the system should be carefully designed with returns which minimize noise transmission through the return air grill. Although the air handler is designed with large blowers operating at moderate speeds, any blower moving a high volume of air will produce audible noise which could be objectionable when the unit is located very close to a living area. It is often advisable to route the return ducts under the floor through the attic. Such design permits the installation of air return remote from the living area (i.e. central hall).*
- Pursuant to Florida Building Code 13-610.2.A.2.1, this unit meets the criteria for a factory sealed air handler.
- If a side return is needed for your application, the side return MUST be installed prior to moving the air handler to its installation location. Unless two side returns are used, the Side Return Kit may not be on the same side as the LV wiring entry point. See the Side Return Kit # BAYSRKIT100A Installer Guide for detailed instructions, if used.
- Study the unit's outline drawing and dimensions prior to selecting the installation site. Note in advance which electrical conduit entry points and condensate drain holes are to be used, so that proper clearance allowances can be made for installation and future maintenance.
- Installation of the air handler must be made prior to, or at the same time as, the installation of the outdoor unit in order to allow access for refrigerant lines.
- Consider the overall space needed when external accessories are used, additional height and width requirements may exist.
- These units are not approved for outdoor installation.
- These units must be installed in the proper air flow direction.
- Any third-party heater accessories, including hydronic coils and duct heaters must be downstream of the unit.
- Note: No atomizing style humidifier is allowed in the return plenum with the use of this unit.
- Excessive bypass air may cause water blow-off, which will adversely affect system operation and air cleaner performance. To verify bypass airflow, follow the Bypass Humidifier Pre-Installation Checkout and Set-Up Procedures available through your local distributor. Ask for publication number 18-CH37D1-* Steam and Flow-through Fan Power Duct-mounted Humidifiers. Follow the humidifier installation instructions. These should only be installed on the supply air side of the system.
- **Note:** *The air handlers have been evaluated in accordance with the Code of Federal Regulations, Chapter XX, Part 3280 or the equivalent. "SUITABLE FOR MOBILE HOME USE."*
- **Important:** *The TAM4A0C60S51 air handler applied in downflow or horizontal configurations should not exceed 2000 CFM. Airflow above 2000 CFM could result in water blow-off. For verification, see airflow table.*
- **Note: This unit is certified to UL 1995. The interior cabinet wall meets the following:**
 - UL94-5VA Flame Class Listed
 - UL723 Steiner Tunnel Listed for 25/50 Flame/Smoke
 - UL746C Listed for Exposure to Ultraviolet Light, Water Exposure and Immersion

Section 7. Setting the Unit – Vertical Installation

7.1 Considerations

Provide a minimum height of 14 inches for proper unrestricted airflow below the unit. Allow a minimum of 21 inches clearance in front of the air handler to permit maintenance and removal of filter.

- Position unit on suitable foundation. If a manufacturer approved accessory is not used, a frame strong enough to support the total weight of the unit, accessories, and duct work must be provided.
- Isolate unit from the foundation using a suitable isolating material.

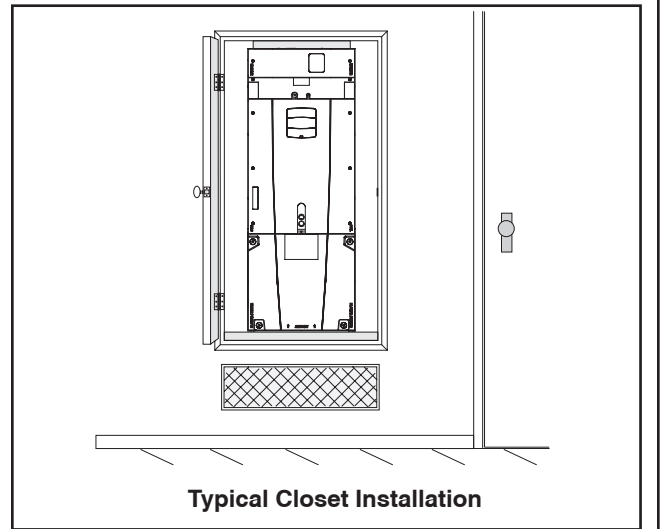

7.2 Upflow Installations

TASB Installation

1. Install the TASB plenum stand with integrated sound baffle using the TASB instructions.

Note: Kit is used for open air applications.

TASB175SB for use with 17.5" cabinets
TASB215SB for use with 21.5" cabinets
TASB235SB for use with 23.5" cabinets
MITISRKIT1620 - Side return kit with 16"x20" filter

Contact your distributor for more information.

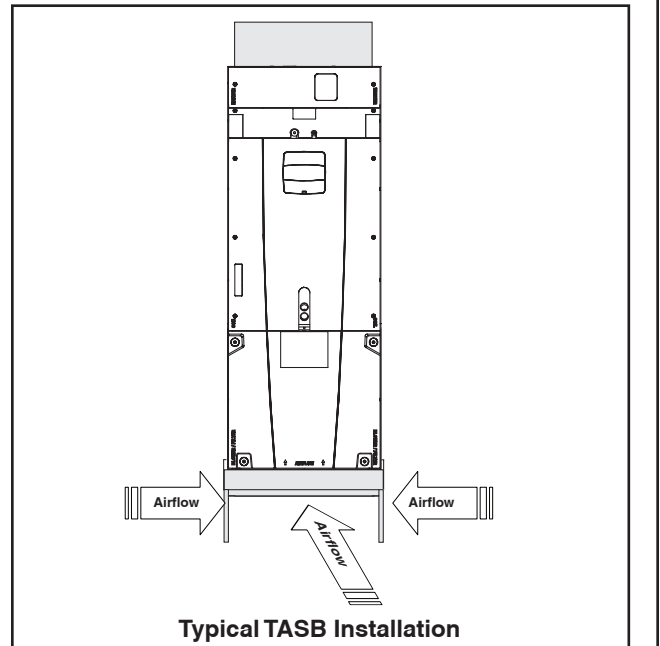

Plenum Installation

1. Assemble the plenum using the plenum's Installer Guide.

On units with sheet metal returns: Return plenum must be flanged. Sheet metal drill point screws must be 1/2" in length or shorter.

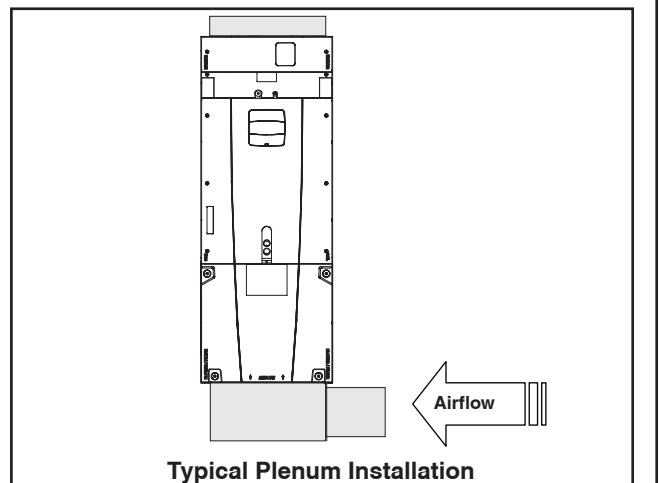

7.3 Downflow Installation

- Downflow installation must comply with national, state, and local codes.
- The air handlers are rated for zero clearance from combustible materials.

STEP 1 - Prepare the location site as appropriate for your application and per national, state, and local code requirements.

STEP 2 - Set the unit in position.

Important: Ensure EEV sensor and motor wiring are taut and wire-tied to the distributor tube to prevent damage during electric heat operation.

Important: For the 5 ton air handler model, tap 5 should not be used in the downflow or horizontal orientations. Using Tap 5 could result in water blowing off the coil.

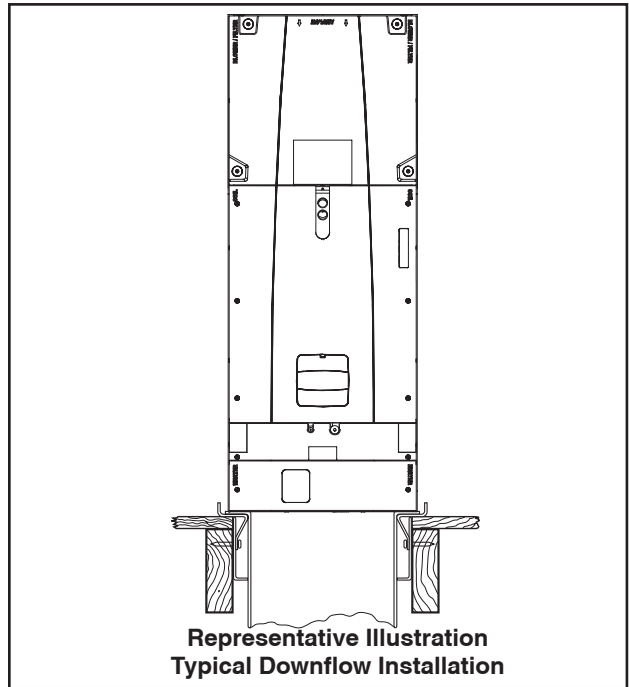

Section 8. Setting the Unit – Horizontal Installation

8.1 Considerations

Important: Due to the unique design of this unit, which allows the electrical wiring to be routed within the insulation, do not screw, cut, or otherwise puncture the unit cabinet in any location other than the ones illustrated in this Installer Guide or in an approved accessory's Installer Guide.

Important: Make certain that the unit has been installed in a level position to ensure proper draining.

Important: Under no conditions should metal strapping be attached to the unit to be used as support mechanisms for carrying or suspension purposes.

STEP 1 - Support the unit from the bottom (near both ends). The service access must remain unobstructed.

Important: The unit can only be supported from the bottom. Do not drill or screw supports into any area of the cabinet.

Note: Do not allow the unit to be used as strain relief.

- Approved bottom support methods are rails, u-channels (Unistrut®), or other load bearing materials.
- The unit must be isolated carefully to prevent sound transmission. Field supplied vibration isolators are recommended.

STEP 2 – Install an auxiliary drain pan under the horizontal air handler to prevent possible damage to ceilings.

- Isolate the auxiliary drain pan from the unit and from the structure.
- Connect the auxiliary drain pan to a separate drain line and terminate according to local codes.

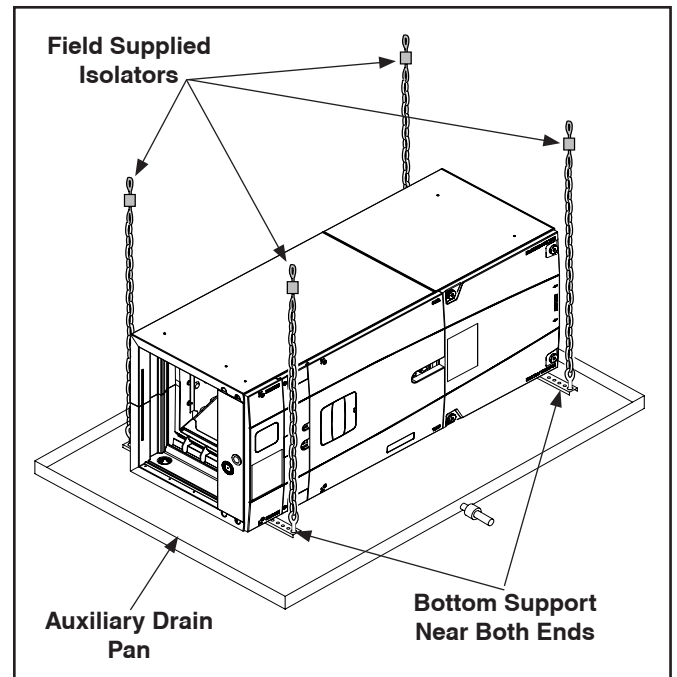

Note: BAYHHKIT001A Hanging Bracket Kit may be ordered separately.

Important: The BAYHHKIT001A may not be used if the cabinet has been altered per Installer Guide 18-GJ58D1-1.

Section 9. Connecting the Duct work

9.1 Duct Connection Considerations

Important: Due to the unique design of this unit, which allows the electrical wiring to be routed within the insulation, do not screw, cut, or otherwise puncture the unit cabinet in any location other than the ones illustrated in this Installer Guide or in an approved accessory's Installer Guide.

Important: Under no conditions should metal strapping be attached to the unit to be used as support mechanisms for carrying or suspension purposes.

Important: On units with sheet metal returns: Return air plenum must be flanged. Sheet metal drill point screws must be 1/2" in length or shorter.

- The supply and return air ducts must be connected to the unit with non flammable duct connectors.
- See the Outline drawing for sizes of the duct connections.
- After the ducts are secured, seal around the supply and return ducts to prevent air leakage.
- Insulate all duct work that will be outside of conditioned spaces.
- Convertible Duct Flange Kits are available to connect the supply plenum or for mounting on the discharge opening to provide a "flush fit" for 1-1/2" duct board applications.
- If front or rear return is required, the air handler must be elevated - placed on a pedestal or plenum and duct must be connected to this pedestal or plenum.
- If side return is required, the Side Return Kit # BAYSRKIT100A accessory must be used. A remote filter will be required.
- To ensure maximum efficiency and system performance, the existing supply and return duct system static pressures must not exceed the total available static pressure of the air handler. Reference ACCA Manual D, Manual S and Manual RS along with the air handler Product Data and Service Facts for additional information.

Note: Side return is not approved without Side Return Kit # BAYSRKIT100. More than one Side Return Kit may be necessary depending on the application. Refer to the Installation Guide in BAYSRKIT100 for approved duct connections, sizing, number, transitions, and accessory application.

Note: Duct work must be supported as appropriate. See National and local codes for guidelines. Do not depend on the unit to support duct work.

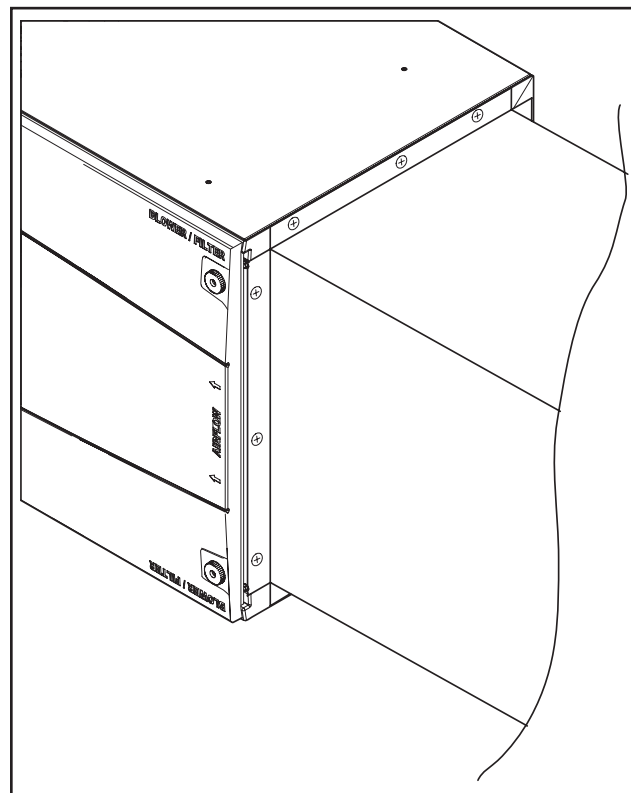
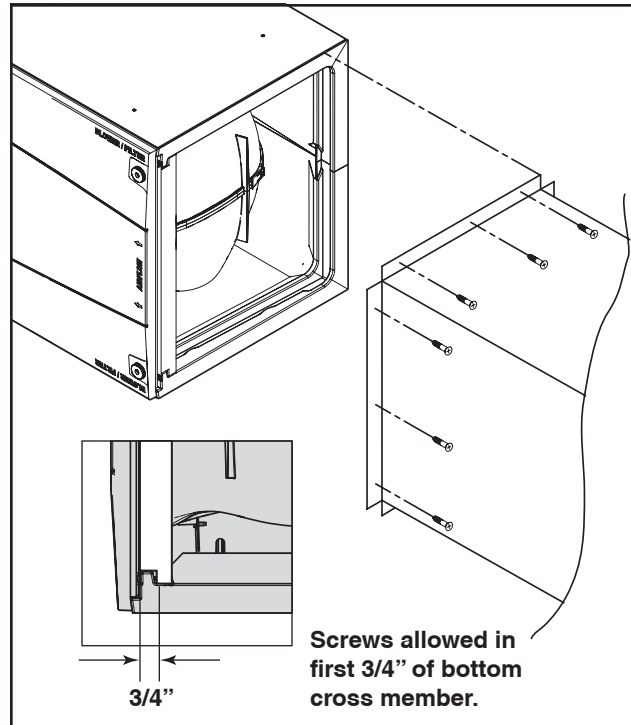

Section 10. Refrigerant Line

10.1 Refrigerant Line Connection Sizes

Table 10.1

Refrigerant Line Set and Connection Sizes		
Model	Vapor Line Connection	Liquid Line Connection
TAM4A0A18S11ED, TAM4A0A18S11SD	3/4	3/8
TAM4A0A24S21ED, TAM4A0A24S21SD	3/4	3/8
TAM4A0A30S21ED, TAM4A0A30S21SD	3/4	3/8
TAM4A0A36S31ED, TAM4A0A36S31SD	3/4	3/8
TAM4A0B42S31ED, TAM4A0B42S31SD	7/8	3/8
TAM4A0C48S41ED, TAM4A0C48S41SD	7/8	3/8
TAM4A0C60S51ED, TAM4A0C60S51SD	7/8	3/8

Note: All AHRI listed systems which are inclusive of the above fan coil units were tested with 25 feet of tubing. The rated tubing diameters are listed in the above tables. However, if refrigeration lines exceed 60 feet, and / or if alternate size existing refrigeration lines are present at the job site, please consult SS-APG006-EN or 32-3312-** (latest version).

10.2 Refrigerant System Layout

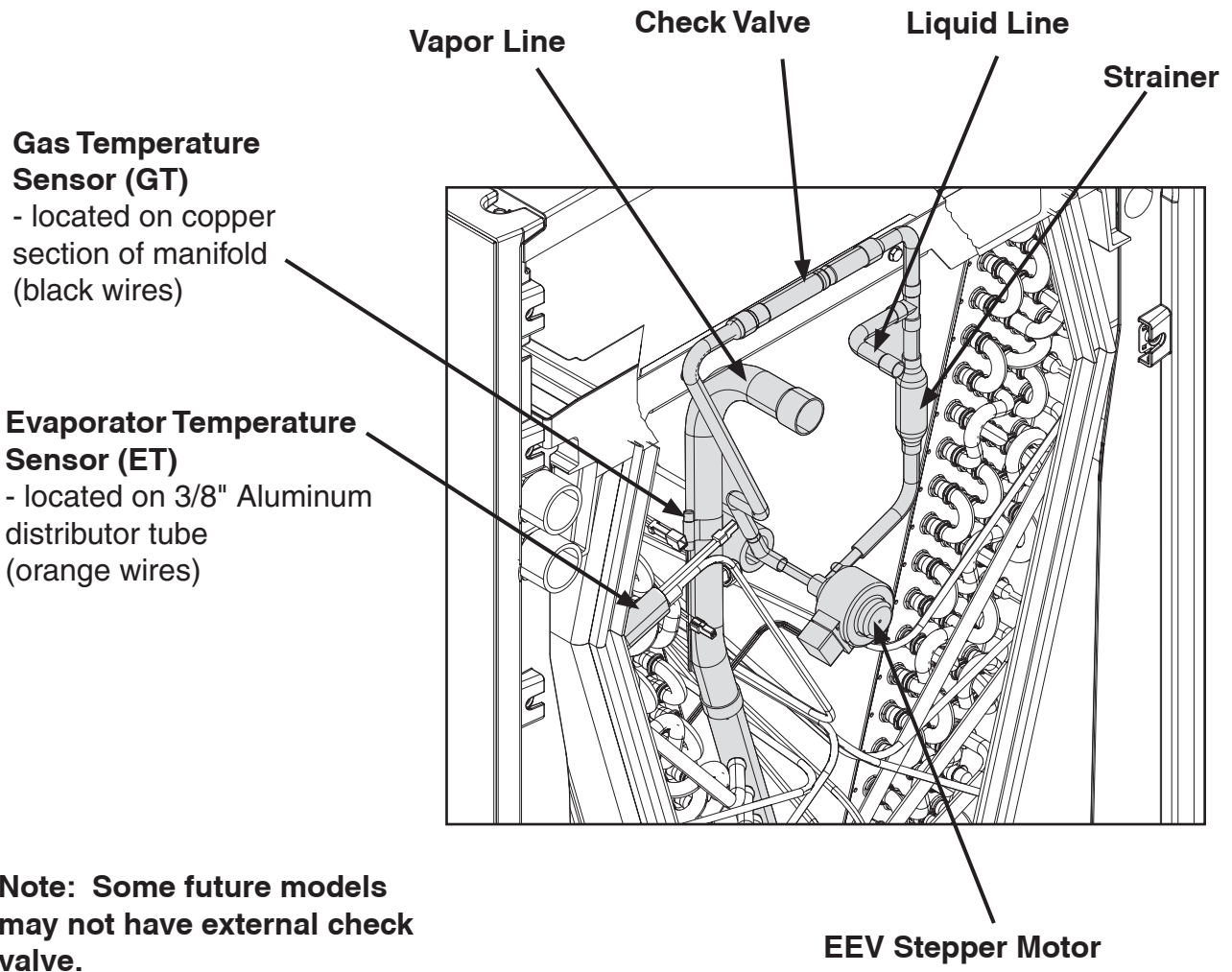

Section 11. Refrigerant Line Brazing

11.1 Braze The Refrigerant Lines

STEP 1 - Remove Heater, Coil, and Line Set panels.
(See Section 2.2 Panel Removal)

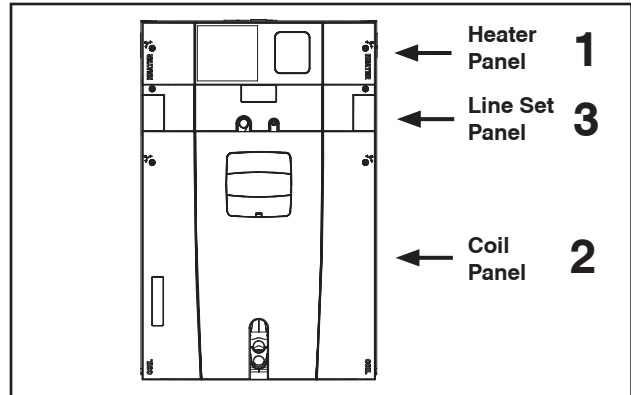

Important: Do NOT unseal coil refrigerant connection stubs until ready to make connections.

STEP 2 - Remove the sealing plug from the indoor coil suction (vapor) line.

STEP 3 - Remove the sealing plug from the indoor coil liquid connection.

Caution: This coil is pressurized with 8-12 psig of dry air. Do not stand directly in front of the coil connections when removing sealing plugs.

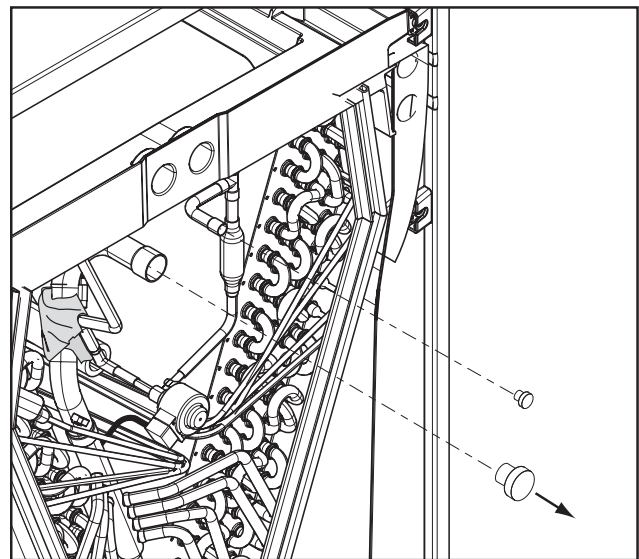

STEP 4 - Connect, but do not braze, field line set to indoor coil.

Allow a minimum of 1.5 inches of refrigerant line set before using an elbow coupling.

Important: Service access to the auxiliary heater must remain unobstructed.

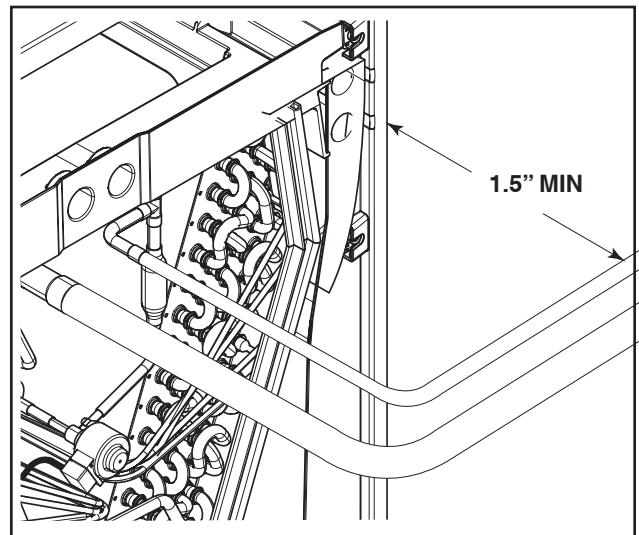

Important: Heat Sensitive Sensors.

The Gas Temperature Sensor must be removed or a wet rag must be wrapped around the suction line between the Sensor and the braze joint to protect it from failure due to overheating.

STEP 5 - Braze refrigerant line connections.

Note: The suction line must be insulated prior to brazing the line set to the air handler stubs.

1. Pull back the insulation before brazing the suction line.
2. Wrap the Gas Temperature Sensor (GT) with a wet rag.
3. Braze the refrigerant line connections.

Important: Care must be taken during brazing to avoid damage to unit components and wiring.

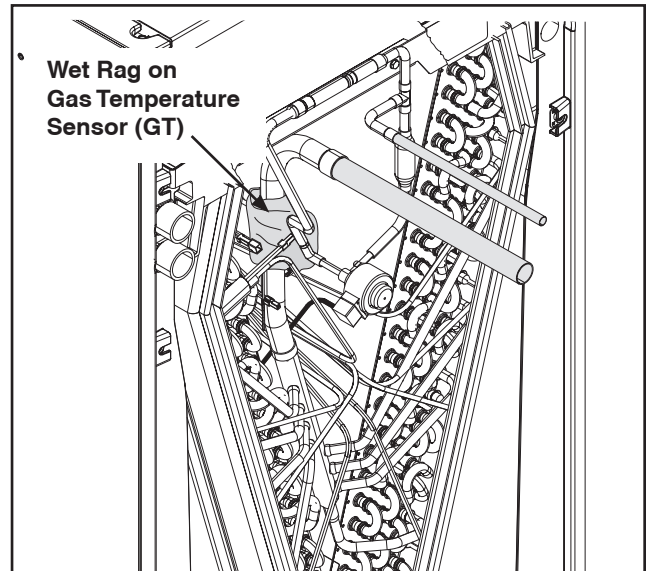

STEP 6 - Pressurize the refrigerant lines and evaporator coil to 150 PSIG using dry nitrogen.

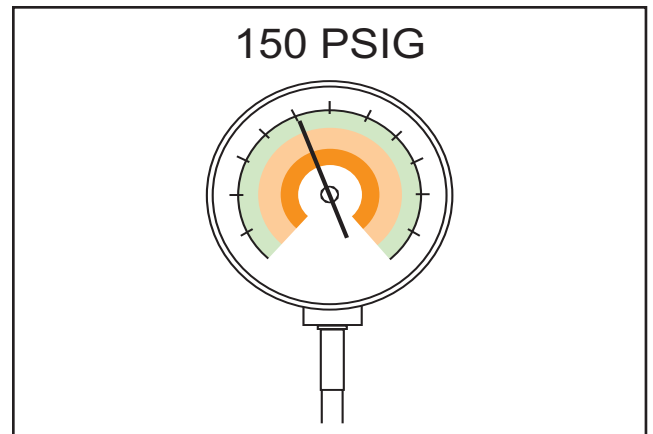

STEP 7 - Check for leaks by using a soapy solution or bubbles at each brazed location.

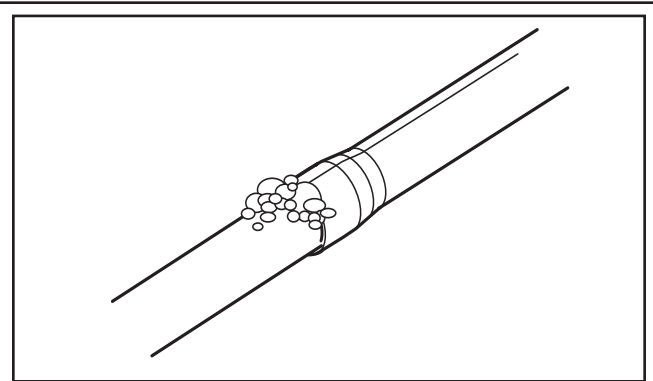

Important: Do not open the service valves until the refrigerant lines and indoor coil leak check and evacuation are complete.

STEP 8 - Evacuate until the micron gauge reads no higher than 350 microns, then close off the valve to the vacuum pump.

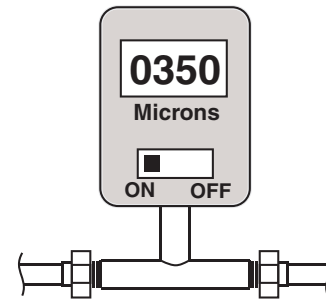

STEP 9 - Observe the micron gauge. Evacuation is complete if the micron gauge does not rise above 500 microns in one (1) minute.

Once evacuation is complete blank off the vacuum pump and micron gauge, and close the valves on the manifold gauge set.

Note: Charge system using Outdoor unit's Installer Guide or Service Facts.



STEP 10 - Replace the Line Set panel.

1. Allow time for tubing to cool.
2. Install grommets to line set piping.

Note: A slight amount of dish soap can be used to aid in the installation of the grommets. Remove any excess from the tubing and grommet after the grommet is installed.

3. Slide the bottom of the Line Set panel down over the refrigerant lines and grommets. The grommets will seal the line openings.

Note: If installing in a horizontal or downflow application, complete the condensate connection preparations per Section 12, Step 3 before installing the Line Set panel.

4. Tighten screws on the Line Set panel.

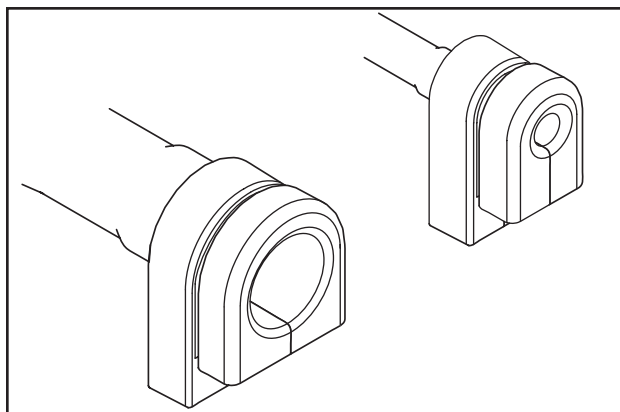
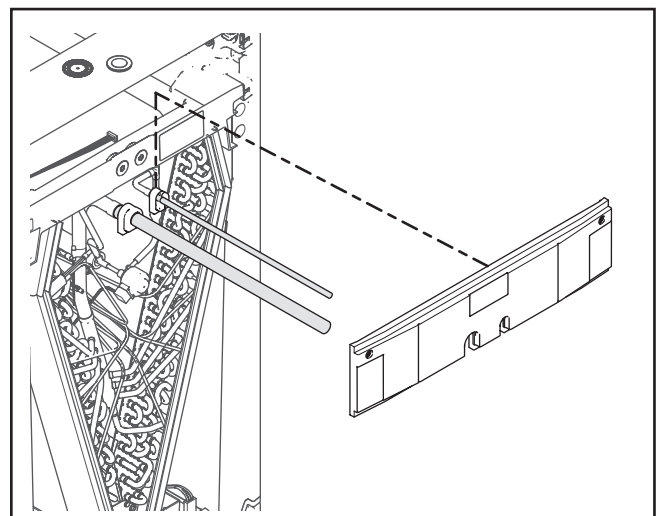
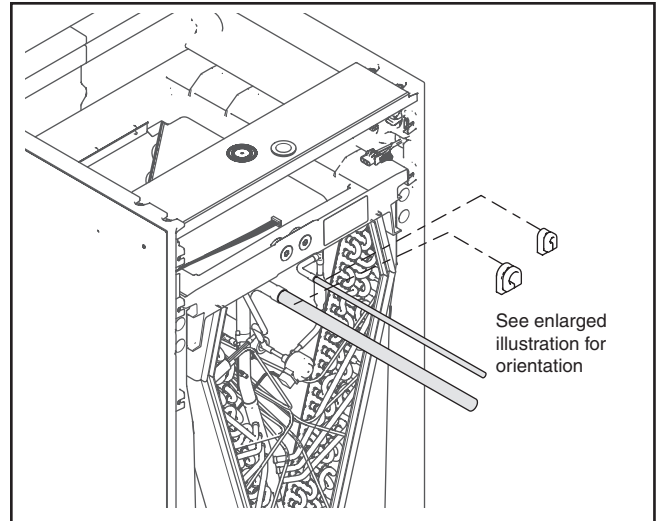

Section 12. Condensate Drain Piping

12.1 Condensate Drain Piping Considerations

- Condensate drain plumbing must comply with national, state, and local codes.
- Route condensate drain lines away from air handler so they do not interfere with access panels.
- Slope the drain lines downward a minimum of 1/4" per foot, support per local codes.
- A 1.5" minimum distance from the coil panel to the inside of the condensate tubing is recommended for coil panel removal.
- Do not use reducing fittings in the condensate drain lines.
- Do not connect the drain line to a closed drain system.
- Do not use a torch or flame near the plastic drain pan coupling.
- A P-trap is not required for proper drainage due to the positive pressure of the air handler; however, it is recommended to prevent efficiency loss of conditioned air.

12.2 Connect Condensate Drain Piping

Note: Downflow and horizontal orientations require the Line Set panel to be removed in order to make the drain connections.

Note: Make certain that the unit has been installed in a level position to allow for proper draining.

STEP 1 - Select the drain connections that are oriented for your application.

STEP 2 - Prepare the condensate drain connections.

- From the factory, the unit comes with plugs in both upflow condensate drains and an additional plug in the documentation packet.
- For upflow applications, remove upflow condensate plug(s) and connect condensate piping.
- For all other applications, do not remove upflow condensate plugs. Remove the cover from the needed condensate drain connections and connect condensate piping.
- If the secondary condensate opening is not used, plug the condensate opening with the fitting supplied in the documentation pack. Use scissors to cut the air seal in half and re-install over the unused opening.

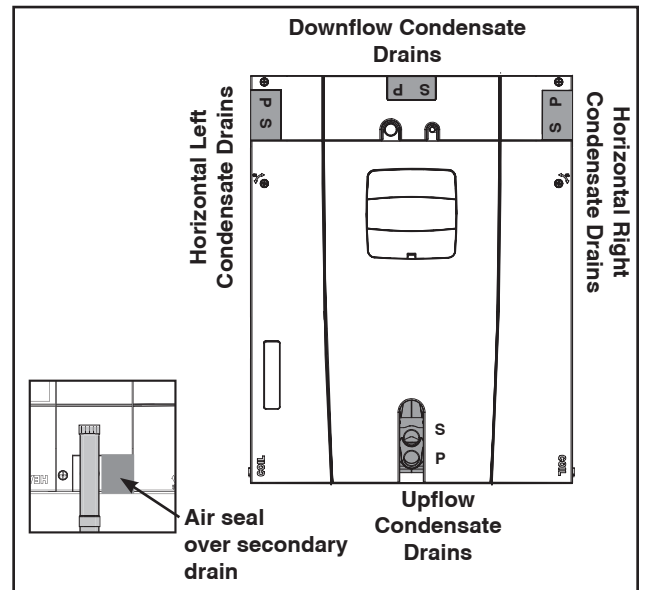

Note: A small amount of sealant must be applied around the drain line(s) passing through the panel to prevent air leakage and possible water drips.

- **Dry fit and test clearance for coil panel removal before applying PVC/CPVC cement**
- **Use Teflon tape on the air handler drain line connections. Do not use pipe joint compound or PVC/CPVC cement on drain nipple.**
- **Hand tighten the drain pipe.**

STEP 3 - For Upflow installations, connect 3/4" PVC pipe to the threaded drain nipple with PVC/CPVC cement. 1.5" minimum clearance to the condensate piping is needed for coil panel removal. Thread the assembly into the primary drain connection (repeat for the secondary drain connection if used).

Important: For Horizontal and Downflow installations, the following order must be observed:

- 1) Remove panel and insert the 3/4" nipples.
- 2) Reinstall the panel.
- 3) Connect the condensate lines to the nipples.

Note: A small amount of sealant must be applied around the drain line(s) passing through the panel to prevent air leakage and possible water drips.

Optional pipe kit BAYCNDPIP01A is available (10 pcs per kit).

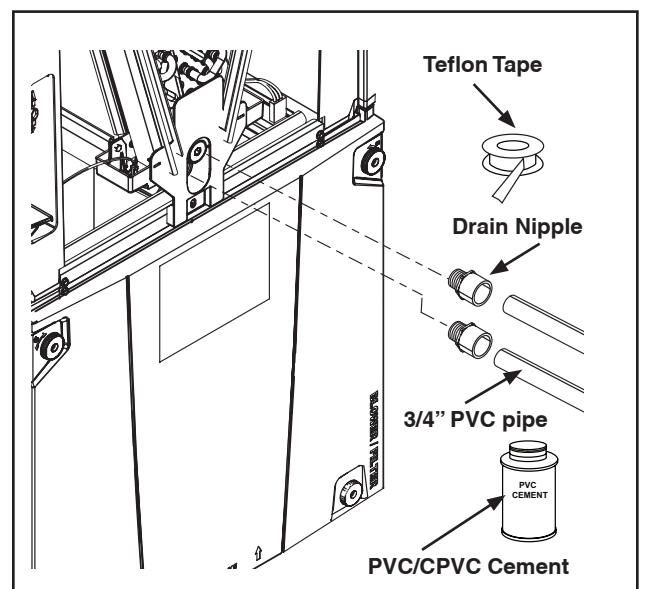

STEP 4 - Install a clean-out tee in the primary drain line for future maintenance. It is recommended that you install a cap on the top of the tee.

1.5" minimum clearance is recommended from cabinet to inside edge of tubing

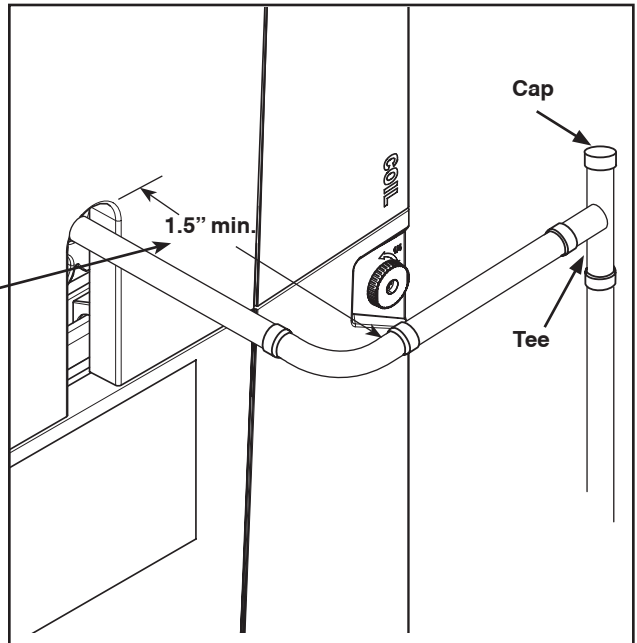

STEP 5 - Insulate the primary drain line to prevent sweating where dew point temperatures may be met. (Optional depending on climate and application needs.)

Provide a means of drainage to prevent winter freeze-up of condensate line. (Optional depending on climate and application needs.)

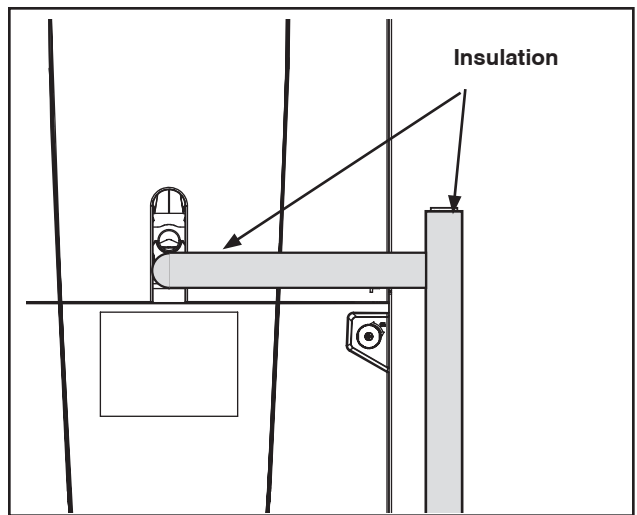

STEP 6 - Support the condensate piping outside the unit per local codes for proper drainage and to prevent sagging.

Allow 1/4" of downward slope for each foot of pipe.

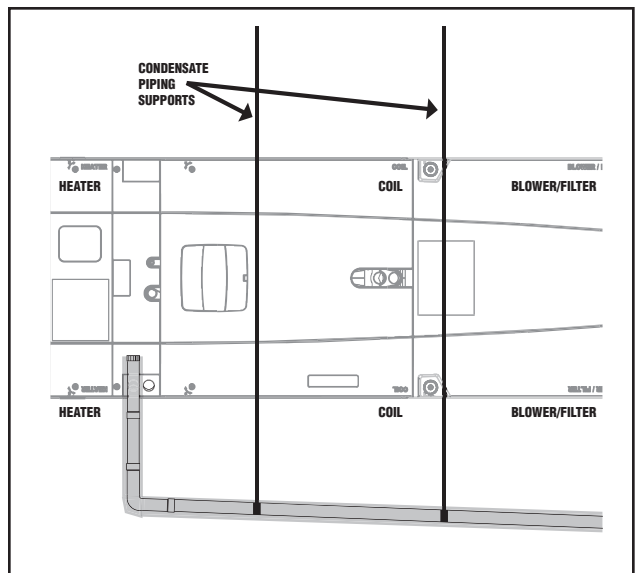

Section 13. Electrical – Low Voltage

13.1 Low Voltage Maximum Wire Length

Table 13.1 defines the maximum total length of low voltage wiring from the outdoor unit, to the indoor unit, and to the thermostat.

24 VOLTS	
WIRE SIZE	MAX. WIRE LENGTH
18 AWG	150 Ft.
16 AWG	225 Ft.
14 AWG	300 Ft.

13.2 Low Voltage Hook-up Instructions

STEP 1 - Remove the Blower panel by removing the four fasteners and then pulling away from the cabinet to remove.

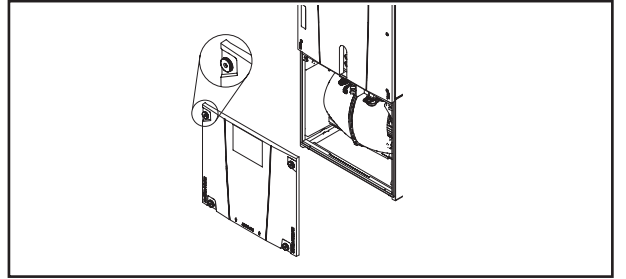

STEP 2 - For Low voltage entry, drill a .5" diameter hole size in side of blower cabinet at location shown on illustration. A 3/8" bushing is supplied in the doc pack.

STEP 3 - Route control wiring to unit and Insert Low voltage wiring.

Note: After the LV wires have been inserted through the new hole, the hole must be sealed.

Note: If a side return kit is used, the LV entry must be on the opposite side of the air handler.

Note: When drilling access through cabinet do not drill into any internal components. Remove internal components before drilling through cabinet if possible. Damage to the air handler or heater could result.

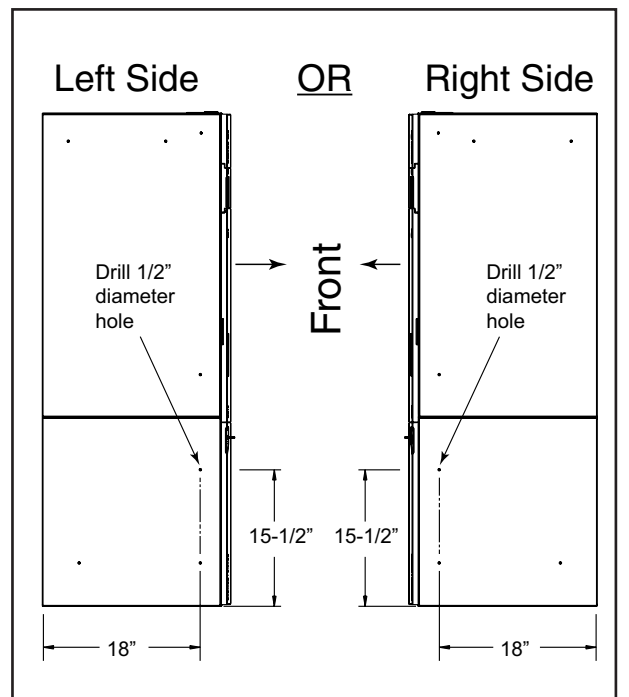

Note: Strain relief must be provided on the inside of the air handler cabinet for the low voltage wiring. Field supplied thermostat wires may be wire tied as a bundle to the existing strain relieved low voltage pigtail leads in the air handler unit.

STEP 4 - Remove the external sheathing of the wiring approximately 5".

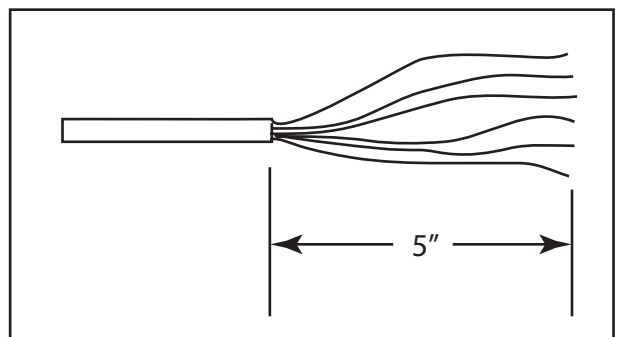

STEP 5 - Using field supplied wire nuts, make connections per hookup diagrams.

Air Handler Hook-up Diagram Cooling

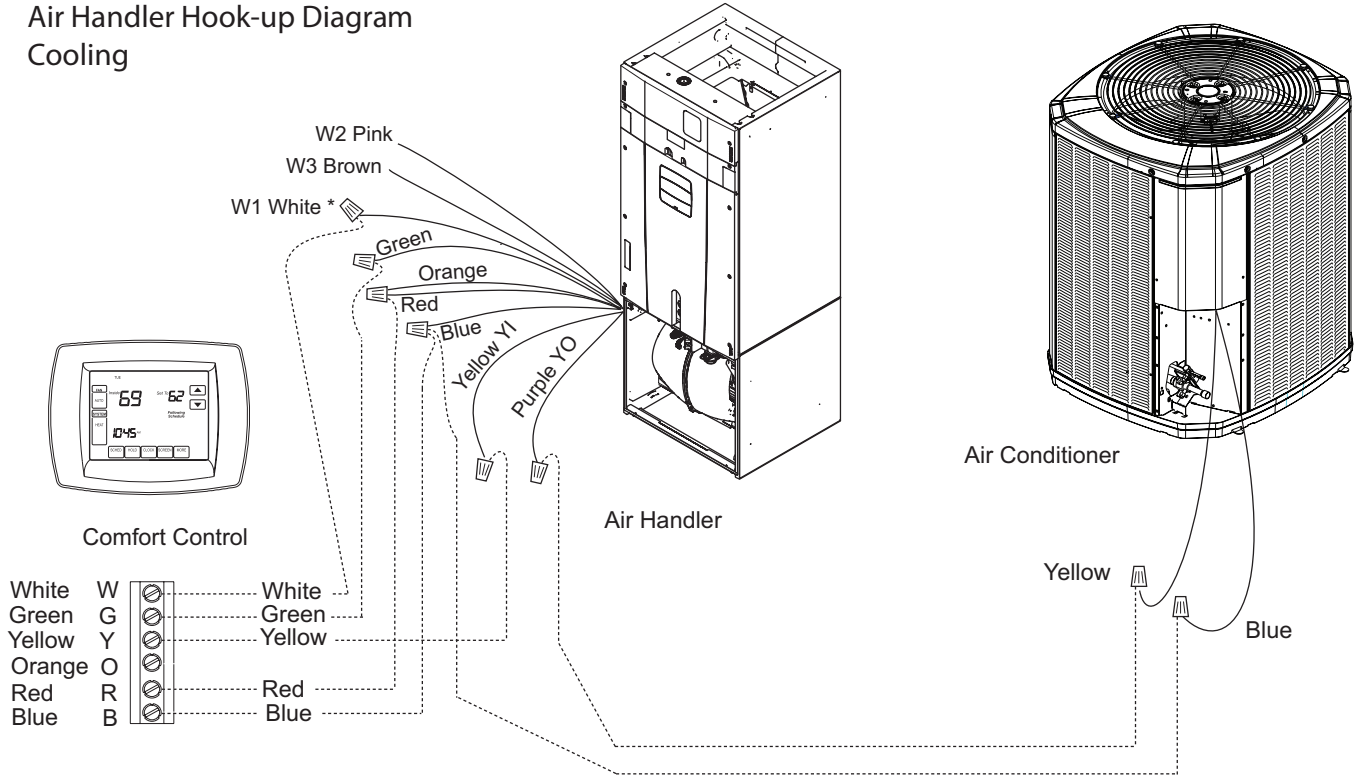

..... Field wiring

- * For multiple stages of electric heat, jumper W1, W2, and W3 together if comfort control has only one stage of heat.
- ** Red to Orange wire connection must be made as shown for cooling only, non-heat pump systems for proper operation.
- Y1 and YO connections must be made as shown for proper operations, freeze protection, and internally mounted condensate overflow circuits to work properly.
- Internally mounted condensate switch is optional and must be ordered separately.
- If 3rd party condensate overflow switches are installed, they should be wired between Y of the thermostat and Y1 of the EEV control.

Air Handler Hook-up Diagram Heat Pump

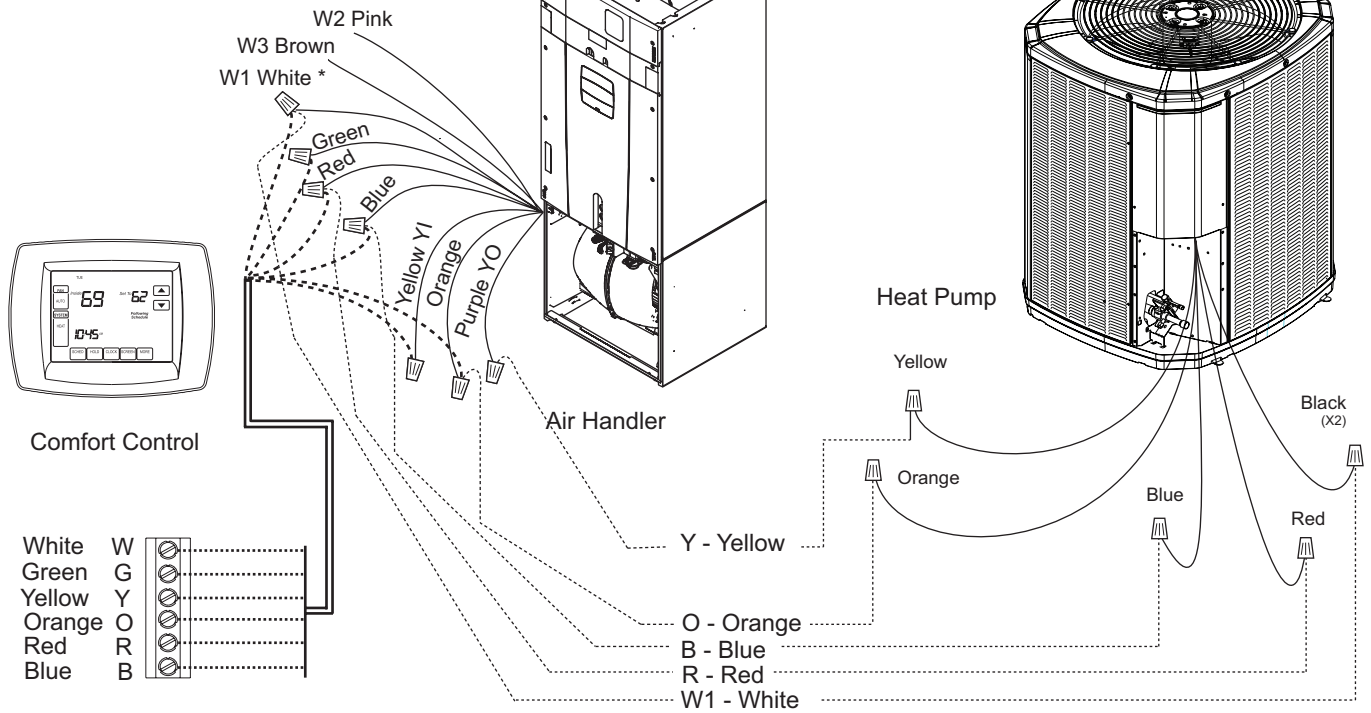

..... Field wiring

- * For multiple stages of electric heat, jumper W1, W2, and W3 together if comfort control has only one stage of heat
- Y1 and YO connections must be made as shown for proper operation, freeze protection, and internally mounted condensate overflow circuits to work properly
- Internally mounted condensate switch is optional and must be ordered separately
- If a 3rd party condensate overflow switch is installed, it should be wired between Y of the thermostat and Y1 of the EEV control.

STEP 6 - Refrigerant Switch

Set the system refrigerant to either R-410A or R-22 using the Refrigerant Switch located on the Expansion Valve Control board (EVC).

Factory default is R-410A.

Note: The power must be shut off and then re-applied in order for the EVC to recognize the change.

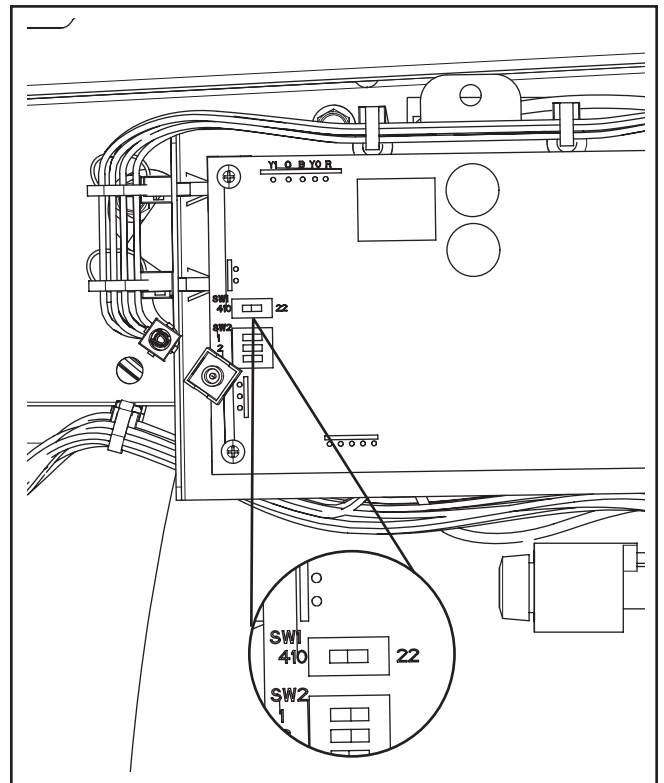

Section 14. Electrical – High Voltage

14.1 High Voltage Power Supply

The high voltage power supply must match the equipment nameplate.

Power wiring, including ground wiring, must comply with national, state, and local codes.

Field wiring diagrams for supplementary electric heaters are shipped with the heater.

⚠ WARNING

LIVE ELECTRICAL COMPONENTS!

During installation, testing, servicing, and troubleshooting of this product, it may be necessary to work with live electrical components. Failure to follow all electrical safety precautions when exposed to live electrical components could result in death or serious injury.

14.2 Make Electrical Connections

STEP 1 - Route High Voltage wiring to unit.

STEP 2 - Select a conduit entry point. Drill a hole for the desired conduit size (up to 1-1/2"). Locating targets are identified on the units.

1. Select the entry point you will use to bring in your high voltage wiring.

Note: When drilling access through cabinet do not drill into any internal components. Remove internal components before drilling through cabinet if possible. Damage to the air handler or heater could result.

Conduit Entry Points

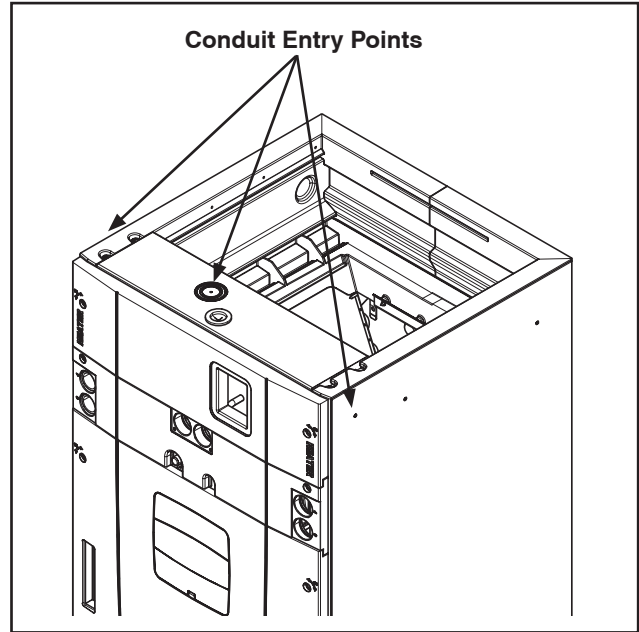

STEP 3 - Route conduit (if used) to the entry point and connect.

1. Use one hand to secure the conduit nut from inside of the heater compartment.
2. Connect field supplied conduit (up to 1-1/2") to conduit nut.

Note: Reducing bushings may be required for your application.

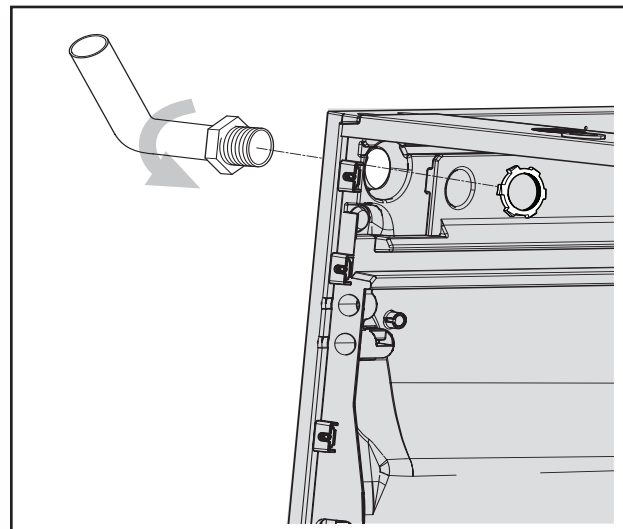

STEP 4 - If an electric heater IS NOT being installed, remove the pigtail harness from the documentation pack and connect it to the plug on the inside of the Heater Compartment in the cabinet.

If an electric heater IS being installed, see the Installer's Guide shipped with the electric heater.

Connect L1, L2, and ground wiring to pigtail harness in Heater Compartment using wire nuts. The incoming ground wiring will mate up with the green wire shown in the illustration.

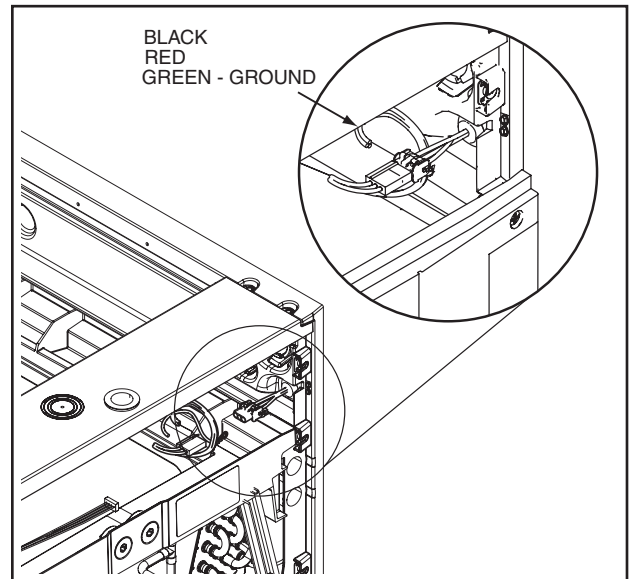

STEP 5 - If the L1, L2, and ground wires enter the case from the left side, use a field supplied 1/2"-5/8" maximum length screw and wire tie to hold the wires to the top center of the Heater Compartment.

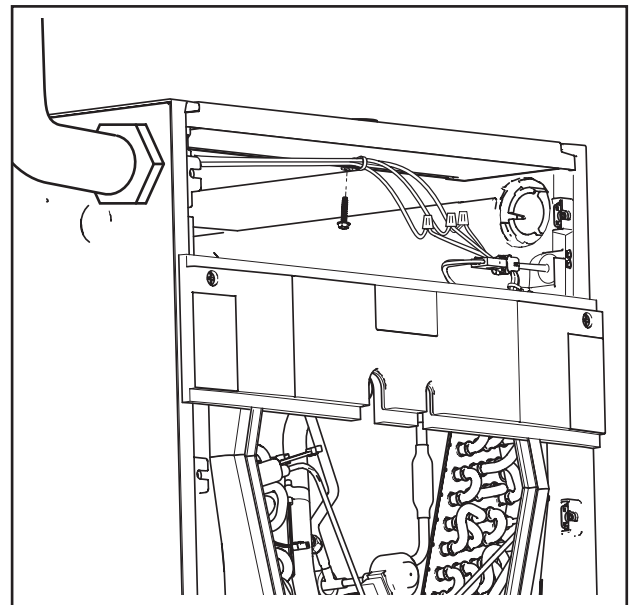

STEP 6 - Reinstall all panels before starting the air handler.

NOTE: After replacing all panels, loosen the Line Set Panel screws approximately 1/4 - 1/2 turn. This will improve the seal between the Heater Panel and Line Set Panel.

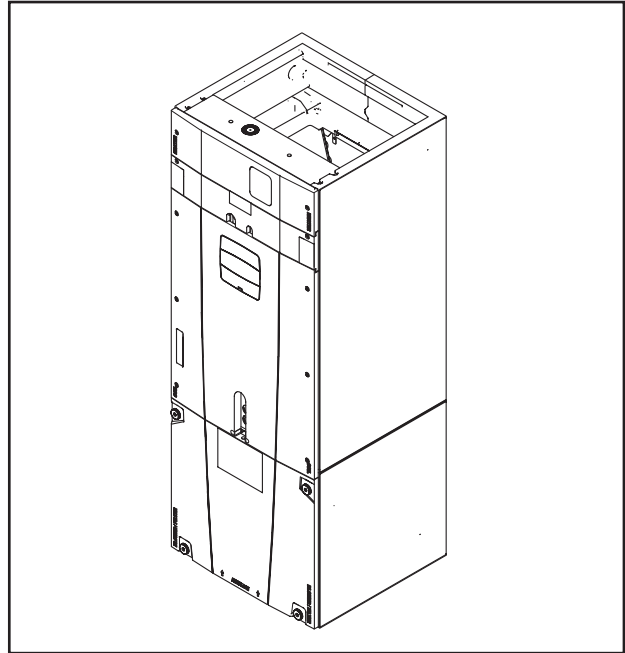

14.3 Secure Coil (All Applications)

STEP 1 - Remove screw and coil panel bracket from documentation packet.

STEP 2 - Place the coil panel bracket into position and use screw to secure the coil panel bracket and seal plate to the support bar.

Important: The Coil Seal Plate and screw secure the coil in the center of the air handler. Failure to follow these steps can prevent the Coil Panel from being easily replaced on the unit.

Important: The Blower Panel may be removed if needed to help align the new screw with the seal plate and crossmember.

Important: For the 5 ton air handler model, tap 5 should not be used in the downflow or horizontal orientations. Using Tap 5 could result in water blowing off the coil.

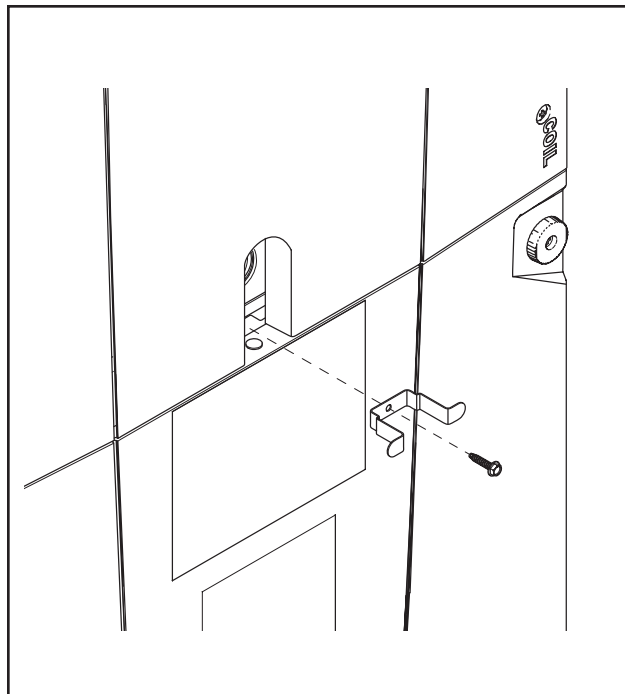

Section 15. Filters

15.1 Filter Considerations

- A filter must be installed within the system.
- A filter channel is provided in the unit, at the bottom of the Blower/Filter compartment.
- For customer ease of filter maintenance, it is recommended that a properly sized remote filter grill(s) be installed for units that are difficult to access. Airflow should not exceed the maximum rated velocity of the filter being used.

Table 15.1 Filter Sizes

Cabinet Size*	A	B	C
Filter Size	16 x 20	20 x 20	22 x 20
* Cabinet size is indicated by the 7th digit in model number.			

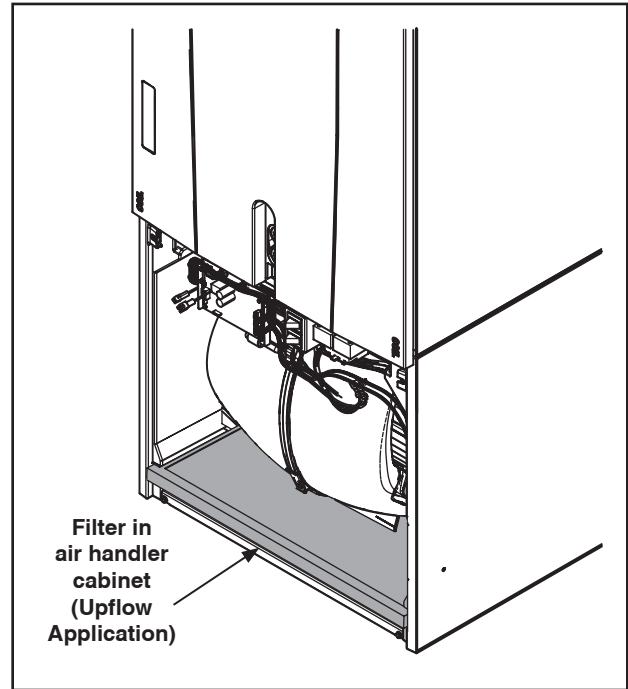

Section 16. Unit Outline Drawing

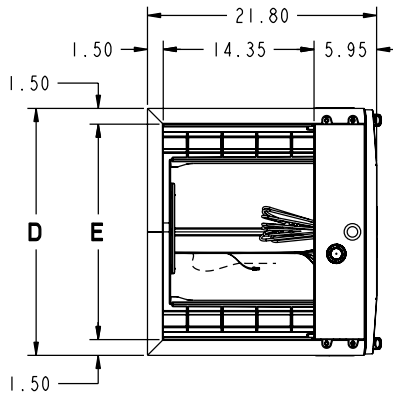

MINIMUM UNIT CLEARANCE TABLE		
	TO COMBUSTIBLE MATERIAL (REQUIRED)	SERVICE CLEARANCE (RECOMMENDED)
SIDES	0"	2"
FRONT	0"	21"
BACK	0"	0"
INLET DUCT	0"	
OUTLET DUCT	0"	

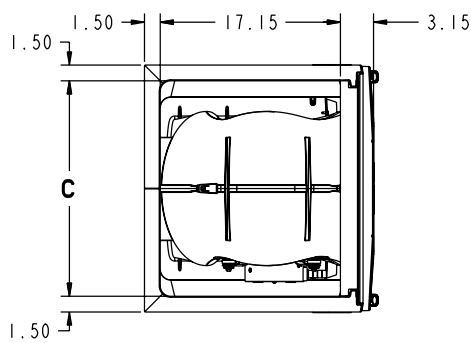
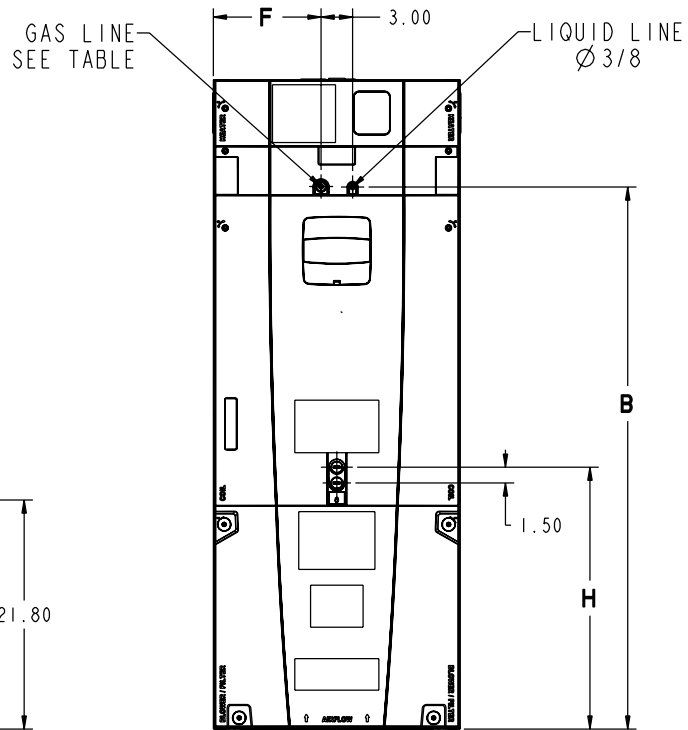
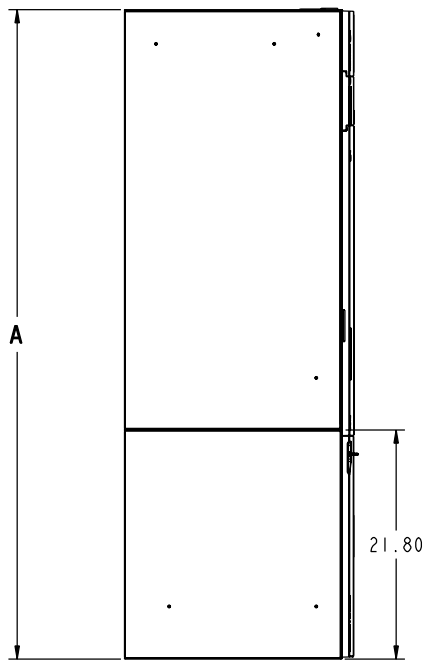

MODEL NO.	A	B	C	D	E	F	H	FLOW CONTROL	GAS LINE BRAZE
TAM4A0A18S11	49.9	39.6	14.5	17.5	14.5	7.3	26.7	EEV	3/4
TAM4A0A24S21	49.9	39.6	14.5	17.5	14.5	7.3	26.7	EEV	3/4
TAM4A0A30S21	49.9	39.6	14.5	17.5	14.5	7.3	26.7	EEV	3/4
TAM4A0A36S31	49.9	39.6	14.5	17.5	14.5	7.3	24.4	EEV	3/4
TAM4A0B42S31	55.7	45.5	18.4	21.3	18.4	9.2	24.8	EEV	7/8
TAM4A0C48S41	56.9	46.7	20.5	23.5	20.5	10.3	24.2	EEV	7/8
TAM4A0C60S51	61.7	51.5	20.5	23.5	20.5	10.3	27.0	EEV	7/8

Section 17. Start Up

17.1 System Start Up

STEP 1 - Make sure all panels are securely in place and that all wiring has been properly dressed and secured.

STEP 2 - Set the system thermostat to OFF.

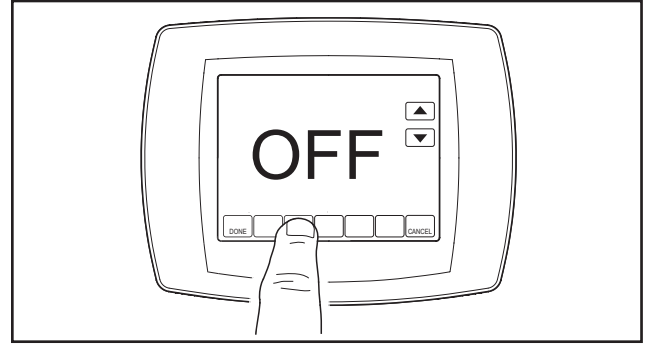

STEP 3 - Turn on electrical power disconnect(s) to apply power to the indoor and outdoor units.

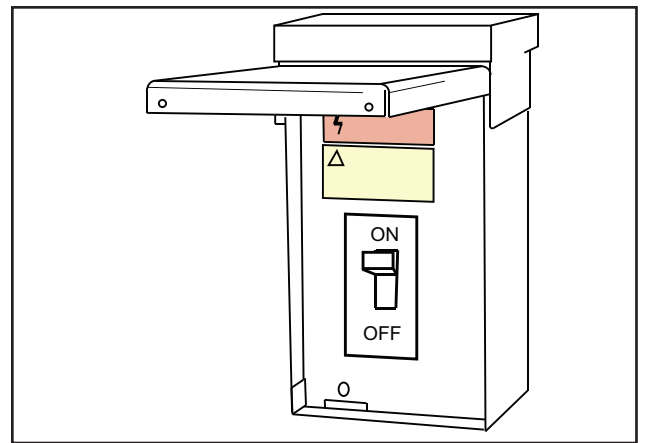

STEP 4 - Set the system thermostat to ON.

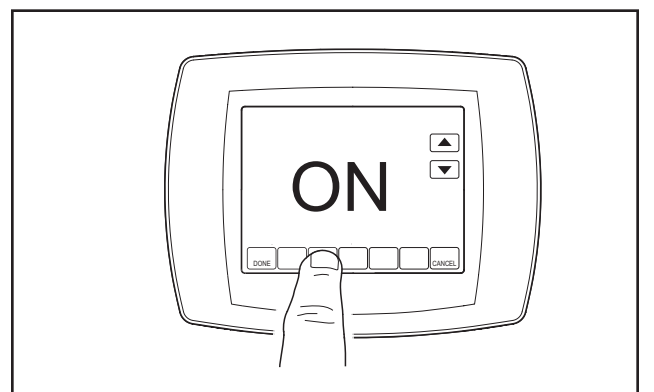

Section 18. Sequence of Operation

18.1 Sequence of Operation

TAM4 Sequence of Operation

Abbreviations

- EVC = Expansion Valve Control
- EEV = Electronic Expansion Valve
- YI = Y signal into the EVC from the comfort control
- YO = Y signal out of the EVC to the outdoor unit

NOTE: Models with a constant torque motor (5 ton / TAM4A0C60S51) do not use blower relay contacts 1 & 3 to energize the motor. The 24VAC signal from the G terminal provides the necessary power to energize the motor.

See unit, electric heat, and field wiring diagrams for additional information.

Continuous Fan

1. R-G contacts close on comfort control sending 24VAC to the blower relay
2. Relay contacts 1 and 3 close
3. The blower will now run on the selected speed. Speed is field selectable

Heatpump OD (cooling)

1. R-Y contacts close on the comfort control sending 24VAC to the YI (Y In) terminal on the EVC.
2. R-G contacts close on comfort control sending 24VAC to the blower relay
3. Relay contacts 1 and 3 close
4. The blower will now run on the selected speed. Speed is field selectable
5. R-O contacts on the comfort control close sending 24VAC to the O terminal on the EVC. This signals the EVC that the unit is in cooling mode. The EVC will control the EEV to maintain the correct superheat.
6. Normally closed contacts on the EVC will pass 24VAC to the YO terminal providing power to the outdoor unit control circuit

Heatpump OD (heating)

1. R-Y contacts close on the comfort control sending 24VAC to the YI (Y In) terminal on the EVC
2. R-G contacts close on comfort control sending 24VAC to the blower relay
3. Relay contacts 1 and 3 close
4. The blower will now run on the selected speed. Speed is field selectable
5. The combination of 24VAC on the Y terminal and zero volts on the O terminal signals the EVC that the unit is in heat-pump heating mode

6. Normally closed contacts on the EVC will pass 24VAC to the YO terminal providing power to the outdoor unit control circuit

Cooling OD

1. R-Y contacts close on the comfort control sending 24VAC to the YI (Y In) terminal on the EVC
2. R-G contacts close on comfort control sending 24VAC to the blower relay
3. Relay contacts 1 and 3 close
4. The blower will now run on the selected speed. Speed is field selectable
5. R-O wired together sends 24VAC to the O terminal on the EVC. This signals the EVC that the unit is in cooling mode. The EVC will control the EEV to maintain the correct superheat
6. Normally closed contacts on the EVC will pass 24VAC to the YO terminal providing power to the outdoor unit control circuit

Electric Heating

1. R-W contacts close on the comfort control sending 24VAC to the EHC to energize the heat relay.
2. R-G contacts close on comfort control sending 24VAC to the blower relay
3. Relay contacts 1 and 3 close
4. The blower will now run on the selected speed. Speed is field selectable
5. Contacts 4 & 6 on the blower relay close providing the interlock circuit to allow the electric heat relays to operate

The comfort control must be setup to control R-G contacts with a call for electric heat. This closes the interlock circuit and allows the heat relay circuit to be energized.

Optional Condensate Switch

1. An optional OEM condensate switch can be installed within the unit. This switch is only available through the National Distribution Center or Global Parts.
2. Switch contacts are normally open and close when water level rises. The closed switch will interrupt current flow to the YO terminal and de-energize the OD unit.
3. Switch is only operational during cooling mode. Condensate overflow is not operational during heating or defrost modes.

Standard aftermarket condensate switches cannot be used within the unit but can be installed exterior of the unit. The 3rd party condensate overflow switch must be wired between Y of the thermostat and YI of the EEV control.

Freeze Protection

1. The EVC control has the ability to sense when the coil is beginning to ice. When this event occurs, the contacts to the YO circuit will open and de-energize the OD unit.
2. The indoor blower motor will continue to run to aid in defrosting the coil. After the coil has sufficiently defrosted, the YO contacts will close and cooling operation will begin again.

Section 19. Checkout Procedures

19.1 Operational And Checkout Procedures

Final phases of this installation are the unit Operational and Checkout Procedures. To obtain proper performance, all units must be operated and charge adjustments made in accordance with procedures found in the Service Facts of the Outdoor Unit.

CHECKOUT PROCEDURE

After installation has been completed, it is recommended that the entire system be checked against the following list:

1. Be sure unit suspension (if used) is secure and that there are no tools or loose debris in or around or on top of the unit. []
2. Properly insulate suction lines and fittings. []
3. Properly secure and isolate all refrigerant lines. []
4. Verify that all electrical connections are tight. []
5. Check all duct outlets; they must be open and unrestricted. []
6. Check drain lines and be sure all joints are tight. []
7. Be sure the return air filter is installed. []
8. Be sure that the correct airflow setting is used. (Indoor Blower Motor). []
9. Operate complete system in each mode to verify proper performance. Verify operation of supplementary electric heater. []

About Trane and American Standard Heating and Air Conditioning
Trane and American Standard create comfortable, energy efficient indoor environments for residential applications.
For more information, please visit www.trane.com or www.americanstandardair.com



The manufacturer has a policy of continuous data improvement and it reserves the right to change design and specifications without notice. We are committed to using environmentally conscious print practices.

18-GJ05D1-12A-EN 16 April 2020
Supersedes 18-GJ05D1-12 (October 2018)

© 2020