

Installer's Guide

Convertible Air Handlers 2 – 5 Ton

TEM6A0B24H21SC
TEM6A0B30H21SC
TEM6A0C36H31SC
TEM6A0C42H41SC
TEM6A0C48H41SC
TEM6B0C60H51SA

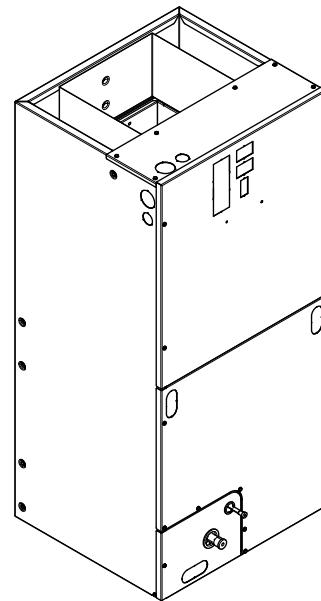
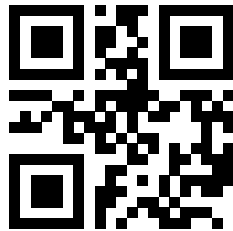

The TEM6 series air handler is designed for installation in a closet, utility room, alcove, basement, crawlspace or attic. These versatile units are applicable to air conditioning and heat pump applications. Several models are available to meet the specific requirements of the outdoor equipment. Field installed electric resistance heaters are available.

▲ SAFETY WARNING

Only qualified personnel should install and service the equipment. The installation, starting up, and servicing of heating, ventilating, and air-conditioning equipment can be hazardous and requires specific knowledge and training. Improperly installed, adjusted or altered equipment by an unqualified person could result in death or serious injury. When working on the equipment, observe all precautions in the literature and on the tags, stickers, and labels that are attached to the equipment.

SAFETY SECTION

Important: This document contains a wiring diagram, a parts list, and service information. This is customer property and is to remain with this unit. Please return to service information pack upon completion of work.

Important: These instructions do not cover all variations in systems nor provide for every possible contingency to be met in connection with the installation. Should further information be desired or should particular problems arise which are not covered sufficiently for the purchaser's purposes, the matter should be referred to your installing dealer or local distributor.

⚠ WARNING

HAZARDOUS VOLTAGE!

Failure to follow this Warning could result in property damage, severe personal injury, or death.

Disconnect all electric power, including remote disconnects before servicing. Follow proper lockout/tagout procedures to ensure the power cannot be inadvertently energized.

⚠ CAUTION

GROUNDING REQUIRED!

Failure to inspect or use proper service tools may result in equipment damage or personal injury. Reconnect all grounding devices. All parts of this product that are capable of conducting electrical current are grounded. If grounding wires, screws, straps, clips, nuts, or washers used to complete a path to ground are removed for service, they must be returned to their original position and properly fastened.

⚠ WARNING

LIVE ELECTRICAL COMPONENTS!

Failure to follow this Warning could result in property damage, severe personal injury, or death.

Follow all electrical safety precautions when exposed to live electrical components. It may be necessary to work with live electrical components during installation, testing, servicing, and troubleshooting of this product.

⚠ WARNING

PRESSURIZED REFRIGERANT!

Failure to follow this Warning could result in personal injury

System contains oil and refrigerant under high pressure. Recover refrigerant to relieve pressure before opening the system. Do not use non-approved refrigerants or refrigerant substitutes or refrigerant additives.

⚠ CAUTION

SHARP EDGE HAZARD!

Failure to follow this Caution could result in property damage or personal injury.

Be careful of sharp edges on equipment or any cuts made on sheet metal while installing or servicing.

⚠ CAUTION

HAZARDOUS VAPORS!

Failure to follow this caution could result in property damage or personal injury.

Equipment corrosion damage. To prevent shortening its service life, the air handler should not be used during the finishing phases of construction or remodeling. The low return air temperatures can lead to the formation of condensate. Condensate in the presence of chlorides and fluorides from paint, varnish, stains, adhesives, cleaning compounds, and cement creates a corrosive condition which may cause rapid deterioration of the cabinet and internal components.

⚠ CAUTION

COIL IS PRESSURIZED!

- Coil is pressurized with approximately 8–12 psi dry air and factory checked for leaks.
- Carefully release the pressure by removing the rubber plug on the liquid line.
- If no pressure is released, check for leaks.

⚠ WARNING

SAFETY HAZARD!

This appliance is not to be used by persons (including children) with reduced physical, sensory, or mental capabilities, or lack of experience and knowledge, unless they have been given supervision or instruction.

⚠ WARNING**SAFETY HAZARD!**

Children should be supervised to ensure that they do not play with the appliance.

⚠ WARNING**WARNING!**

This product can expose you to chemicals including lead, which are known to the State of California to cause cancer and birth defects or other reproductive harm. For more information go to www.P65Warnings.ca.gov.

Important: Installation of this unit shall be made in accordance with the National Electric Code, NFPA No. 90A and 90B, and any other local codes or utilities requirements.

Important: Air handlers do not require repositioning of the coil or drain pan for upflow or horizontal left applications. See the downflow and horizontal right installation sections for application instructions.

Note: Air handlers have been evaluated in accordance with the Code of Federal Regulations, Chapter XX, Part 3280 or the equivalent. "SUITABLE FOR MOBILE HOME USE."

Note: Condensation may occur on the surface of the air handler when installed in an unconditioned space. When units are installed in unconditioned spaces, verify that all electrical and refrigerant line penetrations on the air handler are sealed completely.

Note: The manufacturer recommends installing ONLY A.H.R.I approved, matched indoor and outdoor systems. Some of the benefits of installing approved matched indoor and outdoor split systems are maximum efficiency, optimum performance, and the best overall system reliability.

Features**Table 1. Standard Features**

- MULTI-POSITION UPFLOW, DOWNFLOW, HORIZONTAL LEFT AND HORIZONTAL RIGHT
- PAINTED FINISH ON GALVANIZED STEEL EXTERIOR WITH FULLY INSULATED CABINET THAT MEETS R4.2 VALUE
- STURDY POLYCARBONATE DRAIN PANS
 - These air handlers have factory installed drain pans and are shipped for upflow and horizontal left applications
- 208/230 VAC OPERATION
- VARIABLE-SPEED DIRECT DRIVE BLOWER.
- FACTORY INSTALLED R-410A THERMAL EXPANSION VALVE
- ALL ALUMINUM COIL
- BOTTOM RETURN
- MEETS THE MINIMUM LEAKAGE REQUIREMENTS FOR THE FLORIDA AND CALIFORNIA BUILDING CODES

Table 2. Optional Accessories

- 4,5,8,10,15,20, and 25 KW SINGLE PHASE ELECTRIC HEATERS
 - Circuit breakers available on single phase 4, 5, 8, 10, 15, 20, and 25 KW heaters
 - Lugs available on single phase 4, 5, 8, and 10 KW heaters
 - Lugs available on three phase 10 and 15 KW heaters
- SINGLE POINT POWER ENTRY KIT (for 15 and 20 KW heaters)
- SUPPLY DUCT FLANGE KIT
- DOWNFLOW SUB-BASE KITS - TAYBASE185, TAYBASE235, TAYBASE260
- SLIM FIT FILTER BOX KIT — BAYSF1185AAA, BAYSF1235AAA, BAYSF1265AAA

Table of Contents

Installation Instructions.....	5	Heater Pressure Drop Table	17
Field Wiring	8	Subcooling Adjustment	17
Electrical Data	9	Subcooling Adjustment for	
Performance and Electrical Data.....	10	TEM6A0C48H41 & TEM6B0C60H51	17
Minimum Airflow CFM	15	Coil Conversion Instructions.....	18
Outline Drawing	16	Checkout Procedures	24

Installation Instructions

1. Unpacking

Carefully unpack the unit and inspect the contents for damage. If any damage is found at the time of delivery, proper notification and claims should be made with the carrier.

Check the rating plate to assure model number and voltage, plus any kits match with what you ordered. The manufacturer should be notified within 5 days of any discrepancy or parts shortage.

2. Location

The air handler should be centrally located and may be installed in a closet, alcove, utility room, basement, crawl space or attic. Minimum clearances must be met.

Important: The downflow sub-base may be required with electric heat applications. See minimum clearance table.

The unit should be installed in a level position to ensure proper condensation drainage. Up to an additional 1/4" rise over the width or depth of the unit is allowed to create additional sloping towards the drain. Unit must be positioned between level and 1/4" rise, sloping toward the drain connections.

When the unit is installed in a closet or utility room, the room should be large enough, and have an opening to allow replacement of the unit. All servicing is done from the front and a clearance of 21" is needed for service unless the closet door aligns with the front of the air handler.

If you are installing the unit in an unconditioned space such as an attic or crawl space, you must ensure that the area provides sufficient air circulation to prevent moisture collection on the cabinet during high dew point conditions. A drain pan must be installed under the entire unit when it is installed in or above a finished ceiling or in an unconditioned space.

3. Duct Work

The duct work should be installed in accordance with the NFPA No. 90A "Installation of Air Conditioning and Ventilating systems" and No. 90B "Residential Type Warm Air Heating and Air Conditioning Installation."

The duct work should be insulated in accordance with the applicable requirements for the particular installation as required by HUD, FHA, VA the applicable building code, local utility or other governing body.

4. Condensate Drain

The unit is supplied with primary and auxiliary condensate drains that have 3/4" NPT connections. The primary drain must be trapped outside the unit and piped in accordance with applicable building

codes.

The figure shows the operation of a properly designed trap under normal operating conditions when the blower is running and the condensate is draining. Note the difference in height of the water column must at least equal the normal negative static pressure existing during operation between the cooling coil and blower. It is advisable to have the difference in water column height somewhat greater than the normal maximum operating static to allow for greater static caused by dirty filters or for the bounce of the water column on start up.

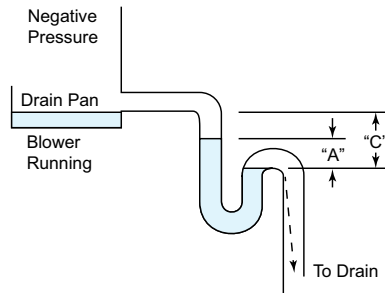

Proper operation of condensate trap under normal operating conditions.

"A" height of water column equals negative static pressure existing in system.

"C" dimension should at least equal two times the maximum negative static pressure that can occur in system.

Do not reduce the drain line size less than the connection size on the drain pan. Condensate should be piped to an open drain or to the outside. All drains must pitch downward away from the unit a minimum of 1/4" per foot of line to ensure proper drainage.

Important: If cleanout Tee is used, stand pipe must be sealed/capped.

Important: If a vent Tee is used, it must be downstream from the trap.

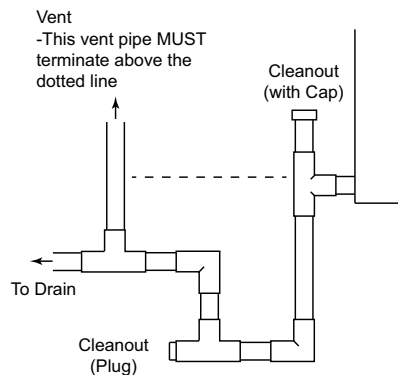

Insulate the primary drain line to prevent sweating where dew point temperatures may be met.

Installation Instructions

(Insulation is optional depending on climate and application needs.)

5. Refrigerant Piping

Refrigerant piping external to the unit shall be sized in accordance with the instructions of the manufacturer of the outdoor equipment.

6. Metering Device

All units are shipped and installed with an internally-checked, non-bleed TXV designed for air conditioning or heat pump operation. Some outdoor models may require a start assist kit. See outdoor unit for more information.

7. Blower

This unit is supplied with a variable speed motor with a direct drive blower wheel which can obtain various air flows. The unit is shipped with factory set cooling and heating air flows. Performance tables are available for additional airflow settings. Disconnect all power to the unit before making any adjustments to the airflow settings. Be sure to check the air flow and the temperature drop across the evaporator coil to ensure sufficient air flow.

8. Airflow Adjustment

⚠ CAUTION

EQUIPMENT DAMAGE!

Failure to follow this procedure may result in equipment damage.

Disconnect power to the air handler before changing dip switch positions.

Blower speed changes are made on the ECM Fan Control. The ECM Fan Control controls the variable speed motor.

There is a bank of 8 dip switches. The dip switches work in pairs to match the airflow for the outdoor unit size (tons). cooling airflow adjustment, Fan off-delay options, and heating airflow adjustment. The switches appear as shown in [Figure 2, p. 6](#)

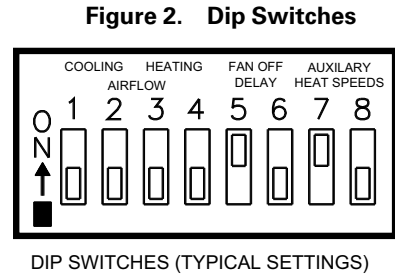
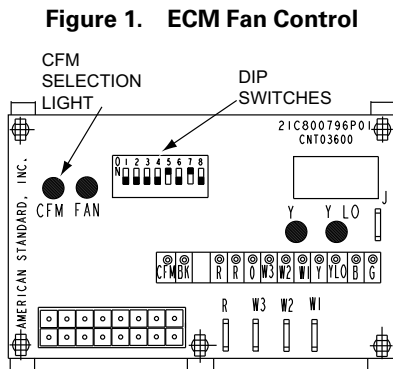

If the airflow needs to be increased or decreased, see the Airflow Label on the air handler or Blower Performance Table.

Be sure to set the correct airflow for cooling and heating.

Switches 1-4 Cooling Airflow

Switches 5-6 Fan Off Delay Options

Switches 7-8 Auxiliary Heat

Indoor Blower Timing

Important: Leave dip switches 5 and 6 in the “as-shipped” positions during system start-up and check out. Afterwards, adjust as desired.

Table 3. Cooling Off – Delay Options

SWITCH SETTINGS		SELECTION	NOMINAL AIRFLOW
5 — OFF	6 — OFF	NONE	SAME
5 — ON	6 — OFF	1.5 MINUTES	100% ^(a)
5 — OFF	6 — ON	3 MINUTES	50%
5 — ON	6 — ON	ENHANCED ^(b)	50-100%

^(a) Default setting

^(b) This ENHANCED MODE selection provides a ramping up and ramping down of the blower speed to provide improved comfort, quietness, and potential energy savings. The graph shows the ramping process.

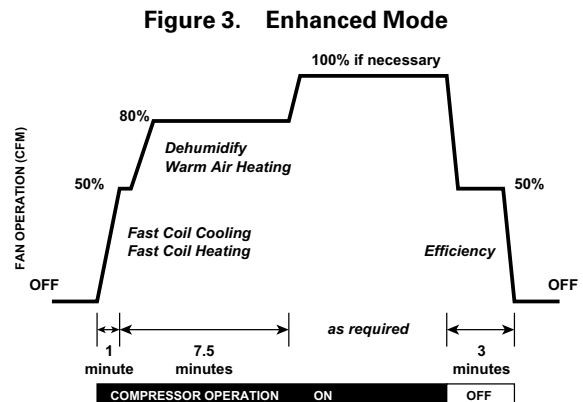

9. Wiring

Consult all schematic and pictorial wiring diagrams of this unit and the outdoor equipment to determine compatibility of wiring connections and to determine specific requirements.

All field wiring to the air handler should be installed in accordance with the latest edition of the National Electric Code NFPA No. 70 and any local codes. Check rating plates on unit for rated volts, minimum circuit ampacity and maximum over current protection. Supply circuit power wiring must be 75 degree C (167 degree F) minimum copper conductors only. Copper supply wires shall be sized to the National Electric Code or local code requirements, whichever is more stringent.

The unit is shipped wired for 230/240 Volt AC 60 HZ 1 Phase Operation. If the unit is to be operated at 208 VAC 60HZ, follow the instructions on the indoor unit wiring diagram to change the low voltage transformer to 208 VAC operation (Ensure unit is properly grounded).

Class 2 low voltage control wiring should not be run in conduit with power wiring and must be separated from power wiring unless class 1 wire with proper voltage rating is used.

Low voltage control wiring should be 18 Awg, color coded (105 degree C minimum). For lengths longer than 100ft., 16 Awg wire should be used. Make certain that separation of control wiring and power wiring has been maintained.

10. Air Filter

To protect the coil, blower and other internal parts from excessive dirt and dust an air filter must be installed before air enters the evaporator coil. A remote filter must be installed. Consult the filter manufacturer for proper sizing and maximum velocity requirements.

Important: Air filters shall meet the test requirements in UL 900.

11. Thermostat

Select a thermostat that is commonly used with HP or AC single stage heating/cooling with electric heat. The thermostat will energize the fan on a demand for heat or cool.

Install the thermostat on an inside wall, away from drafts, lights or other heat sources in a location that has sufficient air circulation from other rooms being controlled by the thermostat.

12. Sequence of Operation Cooling (Cooling only)

When the thermostat calls for cooling, the circuit from R to G is completed. The blower motor is energized directly by the ECM fan control, which receives the 24VAC signal from the thermostat.

The circuit from R to Y is also complete energizing the compressor contactor of the outdoor unit. The contactor will close and start the compressor and condenser fan motor.

Cooling (heat pump)

When the thermostat calls for cooling, the circuit from R to G is completed. The blower motor is energized directly by the ECM fan control, which receives the 24VAC signal from the thermostat.

The circuit from R to Y is also complete energizing the compressor contactor of the outdoor unit. The contactor will close and start the compressor and condenser fan motor.

Circuit R to O energizes the reversing valve to the cooling position.

Heating (heat pump)

When the thermostat calls for heating, the circuit from R to G is completed and the blower motor is energized directly by the ECM fan control, which receives the 24VAC signal from the thermostat.

The circuit from R to Y is also complete energizing the compressor contactor of the outdoor unit. The contactor will close and start the compressor and condenser fan motor.

In the heating mode, the reversing valve of the outdoor unit is not energized.

If the indoor temperature continues to fall, the R to W circuit is completed energizing the electric heat contactor(s).

Heating (electric heat only)

Note: The thermostat must be setup to bring the blower on when the electric heat is energized.

When the thermostat calls for heating, the circuit from R to G is completed and the blower motor is energized directly by the ECM fan control, which receives the 24VAC signal from the thermostat. The circuit from R to W is completed energizing the heating contactor(s).

Defrost

Supplemental heat during defrost can be provided by connecting the X2 (black) wire from the outdoor unit to W1 or W2 at the indoor unit. This will prevent cold air from being discharged from the indoor unit during defrost.

13. Operational and Checkout Procedures

To obtain proper performance, all units must be operated and charge adjustments made in accordance with procedures found in the Service Facts document of the outdoor unit. After installation has been completed, it is recommended that the entire system be checked against the checkout list located at the back of this document. See "[Checkout Procedures](#)," p. 24

Installation Instructions

14. Maintenance

The system air filter(s) should be inspected, cleaned or replaced at least monthly. Make certain that the access panels are replaced and secured properly before placing the unit back in operation. This product is designed for dependable service; however, periodic maintenance should be

scheduled and conducted by trained professional service personnel. This service should be conducted at least annually, and should include testing and inspection of electrical and refrigerant components. The heat transfer surface should be cleaned. The blower motor is permanently lubricated for normal operating conditions.

Field Wiring

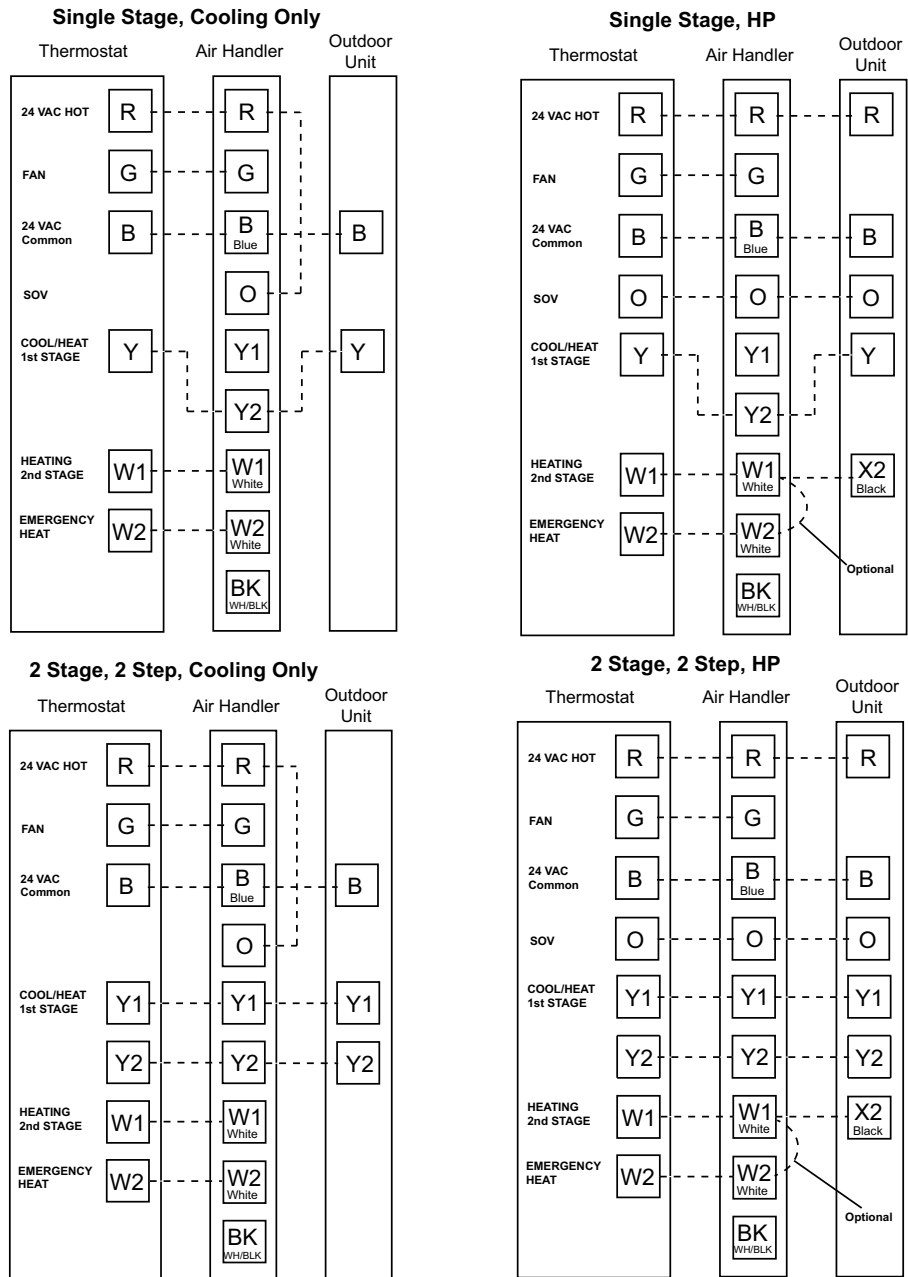

- * Units with pigtails require wirenuts for connections.
- Cap all unused wires.
- For BK enabled comfort control, do not connect Y1 or Y2 at the air handler
- For BK enabled comfort control, cut the jumper wire between R and BK on the control board. See wiring schematic for details.
- In AC systems for multiple stages of electric heat, jumper W1 and W2 together if comfort control has only one stage of heat.

- * Units with pigtails require wirenuts for connections.
- Cap all unused wires.
- For BK enabled comfort control, do not connect Y1 or Y2 at the air handler
- For BK enabled comfort control, cut the jumper wire between R and BK on the control board. See wiring schematic for details.
- In systems for multiple stages of electric heat, jumper W1 and W2 together if comfort control has only one stage of heat.

Electrical Data

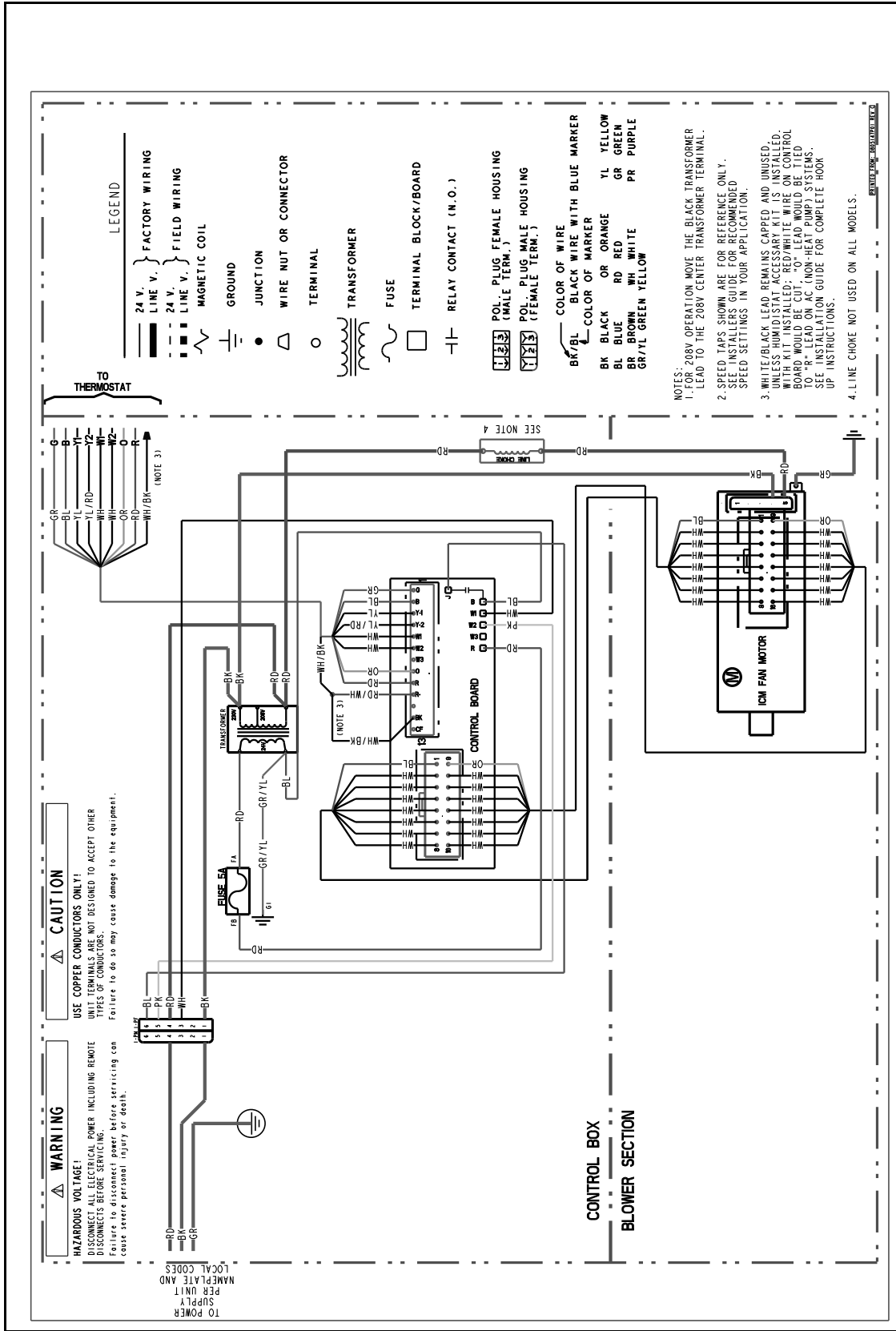

Performance and Electrical Data

Table 4. Air Flow Performance Tables

TEM6A0B24H21SC COOLING AIRFLOW PERFORMANCE, WET COIL, NO FILTER, NO HEATER												
OUTDOOR UNIT SIZE (TONS)	SPEED SETTING	AIRFLOW SETTING	DIP SWITCH SETTING				AIRFLOW POWER	EXTERNAL STATIC PRESSURE				
			SW1	SW2	SW3	SW4		0.1	0.3	0.5	0.7	0.9
1.5	LOW	353 CFM/ton	ON	ON	OFF	ON	CFM Watts	533 52	497 78	461 104	425 130	390 157
	NORMAL	401 CFM/ton	ON	ON	OFF	OFF	CFM Watts	611 65	580 95	548 125	517 155	486 185
	HIGH	451 CFM/ton	ON	ON	ON	OFF	CFM Watts	684 81	668 115	644 148	611 182	570 215
2	LOW	343 CFM/ton	OFF	ON	OFF	ON	CFM Watts	687 82	672 115	648 149	614 182	571 215
	NORMAL	390 CFM/ton	OFF	ON	OFF	OFF	CFM Watts	789 104	798 145	780 183	735 216	663 246
	HIGH	439 CFM/ton	OFF	ON	ON	OFF	CFM Watts	884 135	887 177	882 230	845 274	751 290
2.5	LOW	300 CFM/ton	ON	OFF	OFF	ON	CFM Watts	752 92	749 123	729 167	691 211	636 241
	NORMAL ^(a)	340 CFM/ton	ON	OFF	OFF	OFF	CFM Watts	859 128	861 172	863 211	830 242	727 268
	HIGH	383 CFM/ton	ON	OFF	ON	OFF	CFM Watts	963 172	973 223	995 263	967 291	844 308

^(a) Factory Default Setting

TEM6A0B24H21SC HEATING AIRFLOW PERFORMANCE, NO FILTER, NO HEATER												
OUTDOOR UNIT SIZE (TONS)	SPEED SETTING	AIRFLOW SETTING	DIP SWITCH SETTING				AIRFLOW POWER	EXTERNAL STATIC PRESSURE				
			SW1	SW2	SW3	SW4		0.1	0.3	0.5	0.7	0.9
1.5	LOW	394 CFM/ton	ON	ON	OFF	ON	CFM Watts	599 58	571 88	539 117	502 146	462 175
	NORMAL	448 CFM/ton	ON	ON	OFF	OFF	CFM Watts	680 72	665 109	641 145	610 178	572 209
	HIGH	493 CFM/ton	ON	ON	ON	OFF	CFM Watts	748 89	746 118	682 163	545 208	326 240
2	LOW	393 CFM/ton	OFF	ON	OFF	ON	CFM Watts	785 97	790 128	773 175	735 223	674 253
	NORMAL	446 CFM/ton	OFF	ON	OFF	OFF	CFM Watts	904 131	902 179	912 219	894 253	809 281
	HIGH	491 CFM/ton	OFF	ON	ON	OFF	CFM Watts	980 167	972 216	990 268	974 308	863 324
2.5	LOW	350 CFM/ton	ON	OFF	OFF	ON	CFM Watts	866 125	870 162	866 215	833 263	750 286
	NORMAL ^(a)	398 CFM/ton	ON	OFF	OFF	OFF	CFM Watts	995 171	988 222	1005 271	986 309	872 325
	HIGH	437 CFM/ton	ON	OFF	ON	OFF	CFM Watts	1099 220	1086 274	1098 328	1065 362	918 353

^(a) Factory Default Setting

TEM6A0B30H21SC COOLING AIRFLOW PERFORMANCE, WET COIL, NO FILTER, NO HEATER												
OUTDOOR UNIT SIZE (TONS)	SPEED SETTING	AIRFLOW SETTING	DIP SWITCH SETTING				AIRFLOW POWER	EXTERNAL STATIC PRESSURE				
			SW1	SW2	SW3	SW4		0.1	0.3	0.5	0.7	0.9
1.5	LOW	353 CFM/ton	ON	ON	OFF	ON	CFM Watts	533 52	497 78	461 104	425 130	390 157
	NORMAL	401 CFM/ton	ON	ON	OFF	OFF	CFM Watts	611 65	580 95	548 125	517 155	486 185
	HIGH	451 CFM/ton	ON	ON	ON	OFF	CFM Watts	684 81	668 115	644 148	611 182	570 215
2	LOW	343 CFM/ton	OFF	ON	OFF	ON	CFM Watts	687 82	672 115	648 149	614 182	571 215
	NORMAL	390 CFM/ton	OFF	ON	OFF	OFF	CFM Watts	789 104	798 145	780 183	735 216	663 246
	HIGH	439 CFM/ton	OFF	ON	ON	OFF	CFM Watts	884 135	887 177	882 230	845 274	751 290
2.5	LOW	300 CFM/ton	ON	OFF	OFF	ON	CFM Watts	752 92	749 123	729 167	691 211	636 241
	NORMAL	340 CFM/ton	ON	OFF	OFF	OFF	CFM Watts	859 128	861 172	863 211	830 242	727 268
	HIGH	383 CFM/ton	ON	OFF	ON	OFF	CFM Watts	963 172	973 223	995 263	967 291	844 308

TEM6A0B30H21SC COOLING AIRFLOW PERFORMANCE, WET COIL, NO FILTER, NO HEATER												
3	LOW	310 CFM/ton	OFF	OFF	OFF	ON	CFM	913	947	962	938	883
							Watts	119	172	233	297	364
	NORMAL ^(a)	330 CFM/ton	OFF	OFF	OFF	OFF	CFM	967	1004	1022	1000	947
							Watts	138	194	258	326	397

(a) Factory Default Setting

TEM6A0B30H21SC HEATING AIRFLOW PERFORMANCE, NO FILTER, NO HEATER												
OUTDOOR UNIT SIZE (TONS)	SPEED SETTING	AIRFLOW SETTING	DIP SWITCH SETTING				AIRFLOW POWER	EXTERNAL STATIC PRESSURE				
			SW1	SW2	SW3	SW4		0.1	0.3	0.5	0.7	0.9
1.5	LOW	394 CFM/ton	ON	ON	OFF	ON	CFM	599	571	539	502	462
							Watts	58	88	117	146	175
	NORMAL	448 CFM/ton	ON	ON	OFF	OFF	CFM	680	665	641	610	572
							Watts	72	109	145	178	209
	HIGH	493 CFM/ton	ON	ON	ON	OFF	CFM	748	746	682	545	326
							Watts	89	118	163	208	240
2	LOW	393 CFM/ton	OFF	ON	OFF	ON	CFM	785	790	773	735	674
							Watts	97	128	175	223	253
	NORMAL	446 CFM/ton	OFF	ON	OFF	OFF	CFM	904	902	912	894	809
							Watts	131	179	219	253	281
	HIGH	491 CFM/ton	OFF	ON	ON	OFF	CFM	980	972	990	974	863
							Watts	167	216	268	308	324
2.5	LOW	350 CFM/ton	ON	OFF	OFF	ON	CFM	866	870	866	833	750
							Watts	125	162	215	263	286
	NORMAL	398 CFM/ton	ON	OFF	OFF	OFF	CFM	995	988	1005	986	872
							Watts	171	222	271	309	325
	HIGH	437 CFM/ton	ON	OFF	ON	OFF	CFM	1099	1086	1098	1065	918
							Watts	220	274	328	362	353
3	LOW	325 CFM/ton	OFF	OFF	OFF	ON	CFM	953	990	1007	985	931
							Watts	133	188	251	318	389
	NORMAL ^(a)	346 CFM/ton	OFF	OFF	OFF	OFF	CFM	1010	1049	1066	1047	1000
							Watts	154	212	279	350	426

(a) Factory Default Setting

TEM6A0C36H31SC, TEM6A0C42H41SC COOLING AIRFLOW PERFORMANCE, WET COIL, NO FILTER, NO HEATER												
OUTDOOR UNIT SIZE (TONS)	SPEED SETTING	AIRFLOW SETTING	DIP SWITCH SETTING				AIRFLOW POWER	EXTERNAL STATIC PRESSURE				
			SW1	SW2	SW3	SW4		0.1	0.3	0.5	0.7	0.9
2.5	LOW	300 CFM/ton	ON	ON	OFF	ON	CFM	761	755	719	654	560
							Watts	63	98	131	163	193
	NORMAL	341 CFM/ton	ON	ON	OFF	OFF	CFM	862	861	834	781	700
							Watts	82	120	158	196	235
	HIGH	384 CFM/ton	ON	ON	ON	OFF	CFM	962	963	948	915	863
							Watts	106	147	190	234	279
3	LOW	319 CFM/ton	OFF	ON	OFF	ON	CFM	961	962	947	914	862
							Watts	106	147	189	233	279
	NORMAL	363 CFM/ton	OFF	ON	OFF	OFF	CFM	1092	1093	1082	1060	1026
							Watts	146	192	240	288	337
	HIGH	408 CFM/ton	OFF	ON	ON	OFF	CFM	1231	1231	1221	1203	1175
							Watts	196	249	301	353	404
3.5	LOW	315 CFM/ton	ON	OFF	OFF	ON	CFM	1104	1105	1094	1072	1039
							Watts	150	197	245	293	343
	NORMAL	357 CFM/ton	ON	OFF	OFF	OFF	CFM	1258	1258	1248	1229	1201
							Watts	209	263	317	369	421
	HIGH	402 CFM/ton	ON	OFF	ON	OFF	CFM	1418	1415	1401	1379	1348
							Watts	286	347	406	462	516
4	LOW	308 CFM/ton	OFF	OFF	OFF	ON	CFM	1238	1238	1229	1210	1182
							Watts	199	253	306	357	408
	NORMAL ^(a)	350 CFM/ton	OFF	OFF	OFF	OFF	CFM	1412	1410	1398	1378	1349
							Watts	282	344	404	462	517
	HIGH	394 CFM/ton	OFF	OFF	ON	OFF	CFM	1570	1528	1473	1406	1326
							Watts	393	436	466	483	488

(a) Factory Default Setting

TEM6A0C36H31SC, TEM6A0C42H41SC HEATING AIRFLOW PERFORMANCE, NO FILTER, NO HEATER												
OUTDOOR UNIT SIZE (TONS)	SPEED SETTING	AIRFLOW SETTING	DIP SWITCH SETTING				AIRFLOW POWER	EXTERNAL STATIC PRESSURE				
			SW1	SW2	SW3	SW4		0.1	0.3	0.5	0.7	0.9
2.5	LOW	341 CFM/ton	ON	ON	OFF	ON	CFM	860	863	838	788	707
							Watts	77	115	154	193	232
	NORMAL	379 CFM/ton	ON	ON	OFF	OFF	CFM	949	953	937	906	852
							Watts	98	138	180	224	269
	HIGH	417 CFM/ton	ON	ON	ON	OFF	CFM	1042	1046	1036	1015	980
							Watts	122	166	212	259	308

Performance and Electrical Data

TEM6A0C36H31SC, TEM6A0C42H41SC HEATING AIRFLOW PERFORMANCE, NO FILTER, NO HEATER												
3	LOW	381 CFM/ton	OFF	ON	OFF	ON	CFM	1147	1149	1141	1123	1094
							Watts	154	203	253	303	353
	NORMAL	424 CFM/ton	OFF	ON	OFF	OFF	CFM	1277	1279	1272	1255	1228
							Watts	204	259	314	368	421
	HIGH	466 CFM/ton	OFF	ON	ON	OFF	CFM	1409	1409	1401	1384	1357
							Watts	260	323	383	442	500
3.5	LOW	348 CFM/ton	ON	OFF	OFF	ON	CFM	1222	1224	1216	1200	1174
							Watts	180	232	285	336	388
	NORMAL	386 CFM/ton	ON	OFF	OFF	OFF	CFM	1361	1362	1354	1337	1310
							Watts	240	300	358	415	471
	HIGH	425 CFM/ton	ON	OFF	ON	OFF	CFM	1497	1478	1449	1408	1356
							Watts	316	372	420	461	494
4	LOW	338 CFM/ton	OFF	OFF	OFF	ON	CFM	1360	1361	1353	1336	1309
							Watts	239	299	358	415	470
	NORMAL (a)	375 CFM/ton	OFF	OFF	OFF	OFF	CFM	1511	1489	1456	1412	1355
							Watts	325	380	426	464	493
	HIGH	413 CFM/ton	OFF	OFF	ON	OFF	CFM	1659	1605	1535	1450	1349
							Watts	420	463	488	494	483

(a) Factory Default Setting

TEM6A0C48H41SC, TEM6B0C60H51SA COOLING AIRFLOW PERFORMANCE, WET COIL, NO FILTER, NO HEATER												
OUTDOOR UNIT SIZE (TONS)	SPEED SETTING	AIRFLOW SETTING	DIP SWITCH SETTING				AIRFLOW POWER	EXTERNAL STATIC PRESSURE				
			SW1	SW2	SW3	SW4		0.1	0.3	0.5	0.7	0.9
3	LOW	324 CFM/ton	ON	ON	OFF	ON	CFM	991	985	974	984	994
							Watts	89	133	186	237	303
	NORMAL	368 CFM/ton	ON	ON	OFF	OFF	CFM	1120	1119	1110	1116	1122
							Watts	118	167	224	279	333
	HIGH	423 CFM/ton	ON	ON	ON	OFF	CFM	1282	1286	1281	1280	1282
							Watts	162	219	280	343	402
3.5	LOW	314 CFM/ton	OFF	ON	OFF	ON	CFM	1116	1114	1105	1111	1117
							Watts	117	165	222	277	331
	NORMAL	357 CFM/ton	OFF	ON	OFF	OFF	CFM	1263	1266	1261	1261	1263
							Watts	156	212	273	334	392
	HIGH	411 CFM/ton	OFF	ON	ON	OFF	CFM	1449	1458	1456	1449	1447
							Watts	218	287	352	421	496
4	LOW	298 CFM/ton	ON	OFF	OFF	ON	CFM	1207	1208	1201	1203	1207
							Watts	140	193	252	311	366
	NORMAL	339 CFM/ton	ON	OFF	OFF	OFF	CFM	1368	1374	1370	1367	1367
							Watts	190	252	315	381	448
	HIGH	389 CFM/ton	ON	OFF	ON	OFF	CFM	1564	1577	1577	1567	1561
							Watts	264	343	411	484	570
5	LOW	305 CFM/ton	OFF	OFF	OFF	ON	CFM	1534	1545	1545	1536	1531
							Watts	251	328	394	467	550
	NORMAL (a)	347 CFM/ton	OFF	OFF	OFF	OFF	CFM	1740	1758	1762	1745	1734
							Watts	344	444	518	594	684
	HIGH (b)	399 CFM/ton	OFF	OFF	ON	OFF	CFM	1995	2022	2030	2005	1987
							Watts	484	629	717	783	828

(a) Factory Default Setting

(b) Airflow must not exceed 1800 cfm in horizontal right, horizontal left, and downflow applications due to condensate blowoff. The 5 ton high tap shall not be used in these applications.

TEM6A0C48H41SC, TEM6B0C60H51SA HEATING AIRFLOW PERFORMANCE, NO FILTER, NO HEATER												
OUTDOOR UNIT SIZE (TONS)	SPEED SETTING	AIRFLOW SETTING	DIP SWITCH SETTING				AIRFLOW POWER	EXTERNAL STATIC PRESSURE				
			SW1	SW2	SW3	SW4		0.1	0.3	0.5	0.7	0.9
3	LOW	360 CFM/ton	ON	ON	OFF	ON	CFM	1097	1094	1086	1092	1099
							Watts	112	160	216	271	326
	NORMAL	400 CFM/ton	ON	ON	OFF	OFF	CFM	1215	1216	1210	1211	1215
							Watts	142	196	255	314	369
	HIGH	440 CFM/ton	ON	ON	ON	OFF	CFM	1333	1338	1333	1331	1332
							Watts	178	238	300	365	428
3.5	LOW	348 CFM/ton	OFF	ON	OFF	ON	CFM	1232	1234	1228	1229	1233
							Watts	147	202	261	322	377
	NORMAL	387 CFM/ton	OFF	ON	OFF	OFF	CFM	1366	1373	1369	1366	1365
							Watts	189	252	314	381	447
	HIGH	426 CFM/ton	OFF	ON	ON	OFF	CFM	1500	1511	1510	1502	1498
							Watts	238	311	377	449	529
4	LOW	338 CFM/ton	ON	OFF	OFF	ON	CFM	1364	1370	1366	1363	1363
							Watts	188	251	313	379	446
	NORMAL	375 CFM/ton	ON	OFF	OFF	OFF	CFM	1509	1520	1519	1511	1506
							Watts	241	315	382	453	535
	HIGH	413 CFM/ton	ON	OFF	ON	OFF	CFM	1659	1674	1676	1662	1654
							Watts	305	395	466	541	632

TEM6A0C48H41SC, TEM6B0C60H51SA HEATING AIRFLOW PERFORMANCE, NO FILTER, NO HEATER												
5	LOW	326 CFM/ton	OFF	OFF	OFF	ON	CFM Watts	1637 295	1652 383	1653 453	1641 528	1632 618
	NORMAL (a)	362 CFM/ton	OFF	OFF	OFF	OFF	CFM Watts	1814 381	1834 493	1839 570	1820 645	1807 730
	HIGH	398 CFM/ton	OFF	OFF	ON	OFF	CFM Watts	1990 481	2017 625	2025 713	2000 779	1982 826

(a) Factory Default Setting

Table 5. Electrical Data

TEM6A0B24H21SC HEATER DATA											
Heater Model No.	No. of Circuits/ Phases	240 Volt					208 Volt				
		Capacity		Heater Amps per Circuit	Minimum Circuit Ampacity	Maximum Overload Protection	Capacity		Heater Amps per Circuit	Minimum Circuit Ampacity	Maximum Overload Protection
		kW	BTUH				kW	BTUH			
No Heater				2.5 *	3	15			2.5 *	3	15
BAYHTR1504BRK BAYHTR1504LUG	1/1	3.84	13100	16.0	23	25	2.88	9800	13.8	20	20
BAYHTR1505BRK BAYHTR1505LUG	1/1	4.80	16400	20.0	28	30	3.60	12300	17.3	25	25
BAYHTR1508BRK BAYHTR1508LUG	1/1	7.68	26200	32.0	43	45	5.76	19700	27.7	38	40
BAYHTR1510BRK BAYHTR1510LUG	1/1	9.60	32800	40.0	53	60	7.20	24600	34.6	46	50
BAYHTR1517BRK Circuit 1 (a)	2/1	9.60	32800	40.0	53	60	7.20	24600	34.6	46	50
BAYHTR1517BRK Circuit 2		4.80	16400	20.0	25	25	3.60	12300	17.3	22	25
BAYHTR3510LUG	1/3	9.60	32800	23.1	32	35	7.20	24600	20.0	28	30
BAYHTR3517LUG	1/3	14.40	49100	34.6	46	50	10.80	36900	30.0	40	45

* = Motor Amps

(a) MCA and MOP for circuit 1 contains the motor amps

TEM6A0B30H21SC HEATER DATA											
Heater Model No.	No. of Circuits/ Phases	240 Volt					208 Volt				
		Capacity		Heater Amps per Circuit	Minimum Circuit Ampacity	Maximum Overload Protection	Capacity		Heater Amps per Circuit	Minimum Circuit Ampacity	Maximum Overload Protection
		kW	BTUH				kW	BTUH			
No Heater				4.3 *	5	15			4.3 *	5	15
BAYHTR1504BRK BAYHTR1504LUG	1/1	3.84	13100	16.0	25	25	2.88	9800	13.8	23	25
BAYHTR1505BRK BAYHTR1505LUG	1/1	4.80	16400	20.0	30	30	3.60	12300	17.3	27	30
BAYHTR1508BRK BAYHTR1508LUG	1/1	7.68	26200	32.0	45	45	5.76	19700	27.7	40	40
BAYHTR1510BRK BAYHTR1510LUG	1/1	9.60	32800	40.0	55	60	7.20	24600	34.6	49	50
BAYHTR1517BRK Circuit 1 (a)	2/1	9.60	32800	40.0	55	60	7.20	24600	34.6	49	50
BAYHTR1517BRK Circuit 2		4.80	16400	20.0	25	25	3.60	12300	17.3	22	25
BAYHTR3510LUG	1/3	9.60	32800	23.1	34	35	7.20	24600	20.0	30	30
BAYHTR3517LUG	1/3	14.40	49100	34.6	48	50	10.80	36900	30.0	42	45

* = Motor Amps

(a) MCA and MOP for circuit 1 contains the motor amps

TEM6A0C36H31SC, TEM6A0C42H41SC HEATER DATA											
Heater Model No.	No. of Circuits/ Phases	240 Volt					208 Volt				
		Capacity		Heater Amps per Circuit	Minimum Circuit Ampacity	Maximum Overload Protection	Capacity		Heater Amps per Circuit	Minimum Circuit Ampacity	Maximum Overload Protection
		kW	BTUH				kW	BTUH			
No Heater				4.3 *	5	15			4.3 *	5	15
BAYHTR1504BRK BAYHTR1504LUG	1/1	3.84	13100	16.0	25	25	2.88	9800	13.8	23	25
BAYHTR1505BRK BAYHTR1505LUG	1/1	4.80	16400	20.0	30	30	3.60	12300	17.3	27	30

Performance and Electrical Data

TEM6A0C36H31SC, TEM6A0C42H41SC HEATER DATA											
BAYHTR1508BRK BAYHTR1508LUG	1/1	7.68	26200	32.0	45	45	5.76	19700	27.7	40	40
BAYHTR1510BRK BAYHTR1510LUG	1/1	9.60	32800	40.0	55	60	7.20	24600	34.6	49	50
BAYHTR1517BRK Circuit 1 (a)	2/1	9.60	32800	40.0	55	60	7.20	24600	34.6	49	50
BAYHTR1517BRK Circuit 2		4.80	16400	20.0	25	25	3.60	12300	17.3	22	25
BAYHTR1523BRK Circuit 1 (a)	2/1	9.60	32800	40.0	55	60	7.20	24600	34.6	49	50
BAYHTR1523BRK Circuit 2		9.60	32800	40.0	50	50	7.20	24600	34.6	43	45
BAYHTR3510LUG	1/3	9.60	32800	23.1	34	35	7.20	24600	20.0	30	30
BAYHTR3517LUG	1/3	14.40	49100	34.6	48	50	10.8- 0	36900	30.0	42	45

* = Motor Amps

(a) MCA and MOP for circuit 1 contains the motor amps

TEM6A0C48H41SC, TEM6B0C60H51SA HEATER DATA											
Heater Model No.	No. of Circuits/ Phases	240 Volt					208 Volt				
		Capacity		Heater Amps per Circuit	Minimum Circuit Ampacity	Maximum Overload Protection	Capacity		Heater Amps per Circuit	Minimum Circuit Ampacity	Maximum Overload Protection
		kW	BTUH				kW	BTUH			
No Heater				6.8 *	9	15			6.8 *	9	15
BAYHTR1504BRK BAYHTR1504LUG	1/1	3.84	13100	16.0	29	30	2.88	9800	13.8	26	30
BAYHTR1505BRK BAYHTR1505LUG	1/1	4.80	16400	20.0	34	35	3.60	12300	17.3	30	30
BAYHTR1508BRK BAYHTR1508LUG	1/1	7.68	26200	32.0	49	50	5.76	19700	27.7	43	45
BAYHTR1510BRK BAYHTR1510LUG	1/1	9.60	32800	40.0	59	60	7.20	24600	34.6	52	60
BAYHTR1517BRK Circuit 1 (a)	2/1	9.60	32800	40.0	59	60	7.20	24600	34.6	52	60
BAYHTR1517BRK Circuit 2		4.80	16400	20.0	25	25	3.60	12300	17.3	22	25
BAYHTR1523BRK Circuit 1 (a)	2/1	9.60	32800	40.0	59	60	7.20	24600	34.6	52	60
BAYHTR1523BRK Circuit 2		9.60	32800	40.0	50	50	7.20	24600	34.6	43	45
BAYHTR1525BRK Circuit 1 (a)	4/1	6.00	20500	25.0	40	40	4.50	15400	21.6	36	40
BAYHTR1525BRK Circuit 2		6.00	20500	25.0	31	35	4.50	15400	21.6	27	30
BAYHTR1525BRK Circuit 3		6.00	20500	25.0	31	35	4.50	15400	21.6	27	30
BAYHTR1525BRK Circuit 4		6.00	20500	25.0	31	35	4.50	15400	21.6	27	30
BAYHTR3510LUG	1/3	9.60	32800	23.1	36	40	7.20	24600	20.0	33	35
BAYHTR3517LUG	1/3	14.40	49100	34.6	51	60	10.80	36900	30.0	45	45

* = Motor Amps

(a) MCA and MOP for circuit 1 contains the motor amps

Minimum Airflow CFM

TEM6A0B24H21SC, TEM6A0B30H21SC		
Heater	Minimum Heater Airflow CFM	
	With Heat Pump	Without Heat Pump
BAYHTR1504BRK, BAYHTR1504LUG, BAYHTR1505BRK, BAYHTR1505LUG	660	600
BAYHTR1508BRK, BAYHTR1508LUG	780	600
BAYHTR1510BRK, BAYHTR1510LUG	780	600
BAYHTR1517BRK	1050	850
BAYHTR3510LUG	780	600
BAYHTR3517LUG	900	850

TEM6A0C36H31SC, TEM6A0C42H41SC		
Heater	Minimum Heater Airflow CFM	
	With Heat Pump	Without Heat Pump
BAYHTR1504BRK, BAYHTR1504LUG, BAYHTR1505BRK, BAYHTR1505LUG	875	675
BAYHTR1508BRK, BAYHTR1508LUG	950	820
BAYHTR1510BRK, BAYHTR1510LUG	1000	820
BAYHTR1517BRK	1000	820
BAYHTR3510LUG	875	820
BAYHTR3517LUG	1000	950
BAYHTR1523BRK	1300	1140

TEM6A0C48H41SC, TEM6B0C60H51SA		
Heater	Minimum Heater Airflow CFM	
	With Heat Pump	Without Heat Pump
BAYHTR1504BRK, BAYHTR1504LUG, BAYHTR1505BRK, BAYHTR1505LUG	1200	975
BAYHTR1508BRK, BAYHTR1508LUG	1350	975
BAYHTR1510BRK, BAYHTR1510LUG	1350	975
BAYHTR1517BRK	1365	975
BAYHTR3510LUG	1300	975
BAYHTR3517LUG	1365	1120
BAYHTR1523BRK	1365	1300
BAYHTR1525BRK	1810	1505

TEM6A0B24H21SC, TEM6A0B30H21SC Airflow Performance with Auxiliary Heat				
Airflow Settings	Dip Switch Settings		Nominal Airflow	See following tables for heater application: - Pressure Drop for Electrical Heaters - Minimum Heating Airflow Matrix (on unit nameplates)
	Switch 7	Switch 8		
Low	ON	ON	601	
Med-Lo	OFF	ON	661	
Med-Hi	ON	OFF	781	
High	OFF	OFF	973	

TEM6A0C36H31SC, TEM6A0C42H41SC Airflow Performance with Auxiliary Heat				
Airflow Settings	Dip Switch Settings		Nominal Airflow	See following tables for heater application: - Pressure Drop for Electrical Heaters - Minimum Heating Airflow Matrix (on unit nameplates)
	Switch 7	Switch 8		
Low	ON	ON	696	
Med-Lo	OFF	ON	825	
Med-Hi	ON	OFF	1150	
High	OFF	OFF	1298	

TEM6A0C48H41SC, TEM6B0C60H51SA Airflow Performance with Auxiliary Heat				
Airflow Settings	Dip Switch Settings		Nominal Airflow	See following tables for heater application: - Pressure Drop for Electrical Heaters - Minimum Heating Airflow Matrix (on unit nameplates)
	Switch 7	Switch 8		
Low	ON	ON	1000	
Med-Lo	OFF	ON	1130	
Med-Hi	ON	OFF	1354	
High	OFF	OFF	1596	

Outline Drawing

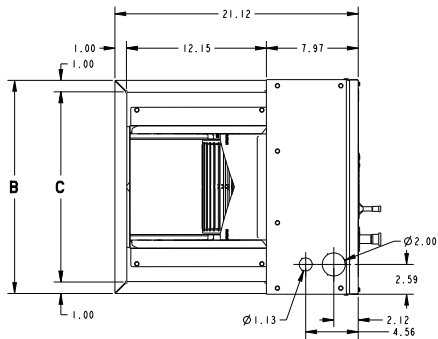

MINIMUM UNIT CLEARANCE TABLE	
	SERVICE CLEARANCE (RECOMMENDED)
SIDES	2"
FRONT	21"
BACK	0"
INLET DUCT	1"
OUTLET DUCT	N/A

NOTE: THIS UNIT IS APPROVED FOR INSTALLATION CLEARANCES TO COMBUSTIBLE MATERIAL AS STATED ON THE UNIT RATING NAMEPLATE

ALL DIMENSIONS ARE REFERENCE DIMENSIONS

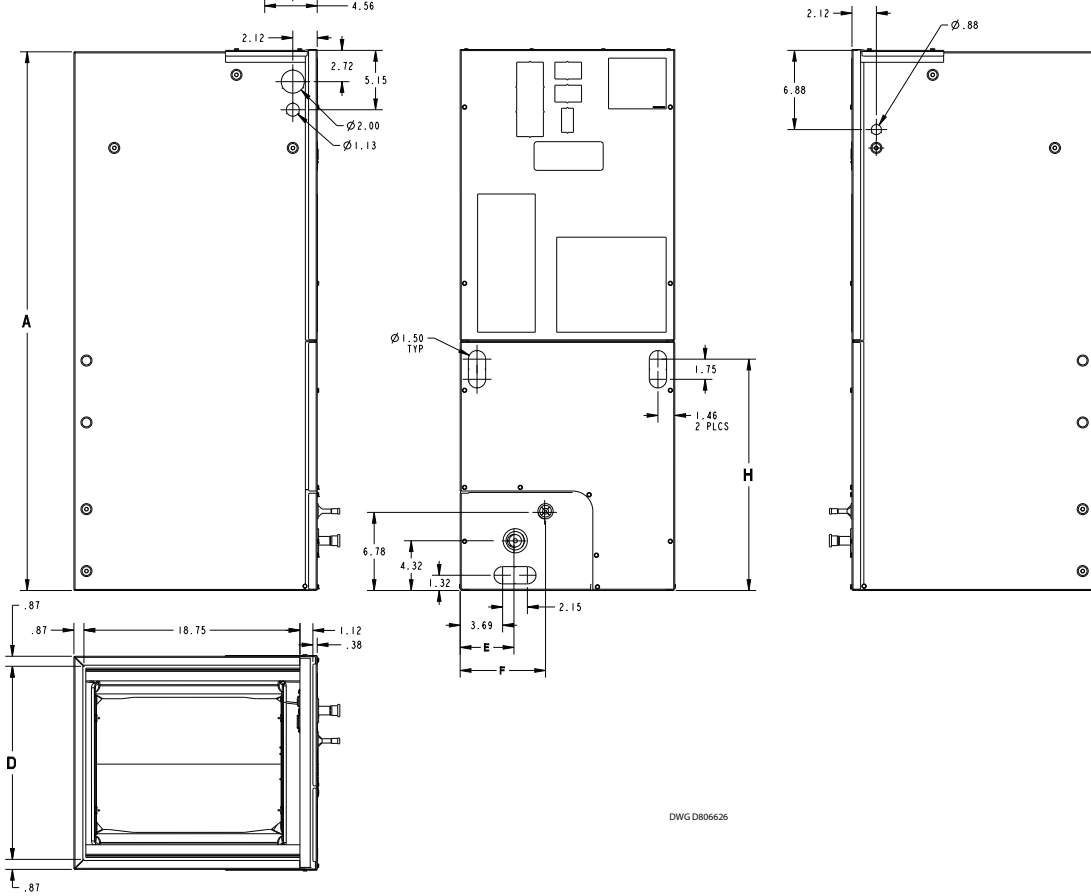

DWG D806626

PRODUCT DIMENSIONS									
Air Handler Model	A	B	C	D	E	F	H	Flow Control	Gas Line Braze
TEM6A0B24, 30	46.77	18.50	16.50	16.75	4.68	7.33	20.09	TXV	3/4
TEM6A0C36, 42	51.27	23.50	21.50	21.75	7.01	9.66	24.59	TXV	7/8
TEM6A0C48/ TEM6B0C60	57.40	23.50	21.50	21.75	4.68	9.66	27.19	TXV	7/8

All dimensions are in inches

Heater Pressure Drop Table

Airflow CFM	Number of Racks				Heater Racks	
	1	2	3	4	Heater Model	No. of Racks
	Air Pressure Drop — Inches W.G.					
1800	0.02	0.04	0.06	0.14	BAYHTR1504	1
1700	0.02	0.04	0.06	0.14	BAYHTR1505	1
1600	0.02	0.04	0.06	0.13	BAYHTR1508	2
1500	0.02	0.04	0.06	0.12	BAYHTR1510	2
1400	0.02	0.04	0.06	0.12	BAYHTR1517	3
1300	0.02	0.04	0.05	0.11	BAYHTR3510	3
1200	0.01	0.04	0.05	0.10	BAYHTR3517	3
1100	0.01	0.03	0.05	0.09	BAYHTR1523	4
1000	0.01	0.03	0.04	0.09	BAYHTR1525	4
900	0.01	0.03	0.04	0.08		
800	0.01	0.03				
700	0.01	0.02				
600	0.01	0.02				

Subcooling Adjustment

System Matched with:	Indoor Unit Model No.	Outdoor Model No.	Subcooling
16 SEER HP — 2 ton	TEM6A0C36H31	4TWR6024H1000A 4TWX6024H1000A 4A6H6024H1000A	13 Degrees
15 SEER HP — 2 ton	TEM6A0B24H21 TEM6A0B30H21	4TWR5024G1000A 4A6H5024G1000A	14 Degrees
15 SEER HP — 3 ton	TEM6A0B30H21 TEM6A0C36H31 TEM6A0C42H41	4TWR5036G1000A 4A6H5036G1000A	14 Degrees

All other matches must be charged per the nameplate charging instructions

Subcooling Adjustment for TEM6A0C48H41 & TEM6B0C60H51

Sub-Cooling Charge Specification For AHRI Rated Performance		
OD Equipment	Up Flow / Horizontal	Down Flow
AC UNIT	OD Name Plate	OD Name Plate
HP UNIT ≤ 3.5 Tons	OD Name Plate	OD Name Plate + 4 Degrees
HP UNIT = 4 and 5 Tons	OD Name Plate	OD Name Plate

Coil Conversion Instructions

Downflow

Follow the conversion steps when installing the air handler in downflow configuration.

1. Remove the front panels panel from the air handler. The coil and line set panel do not need to be separated.
2. Remove the fasteners on both sides of the coil.
3. Remove the two screws holding the center horizontal bracket and rotate out of place. Retain parts.

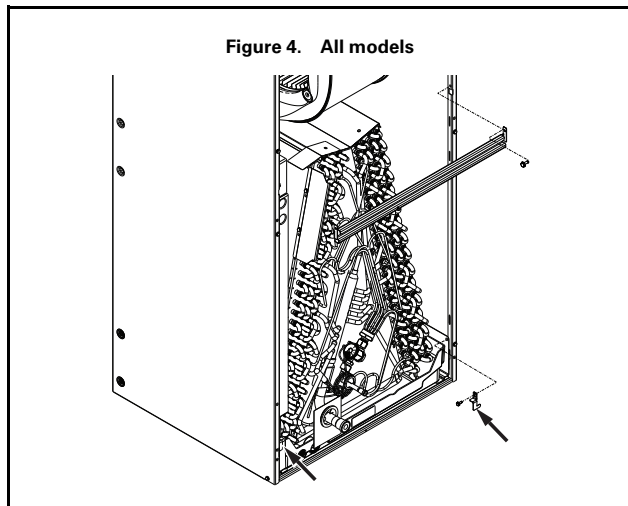

4. Slide the coil assembly out. Remove and discard the horizontal drain pan.

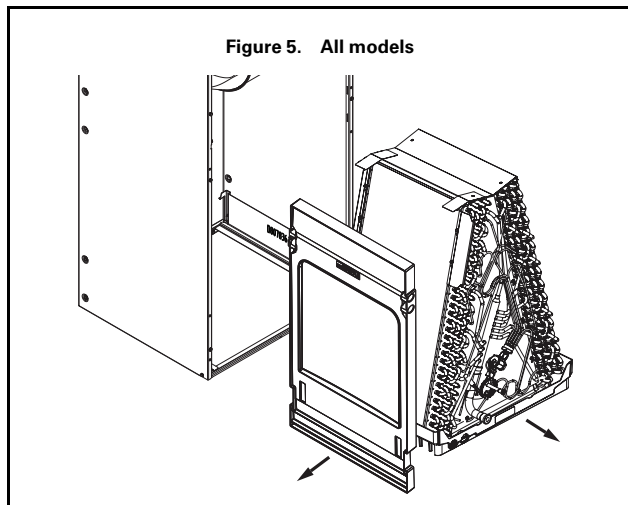

5. On both sides of the cabinet, remove the screws that hold the coil support brackets and retain for later use. Seal the holes to prevent air leakage.

6. Rotate and lift the two coil support brackets to remove from front slots in cabinet.

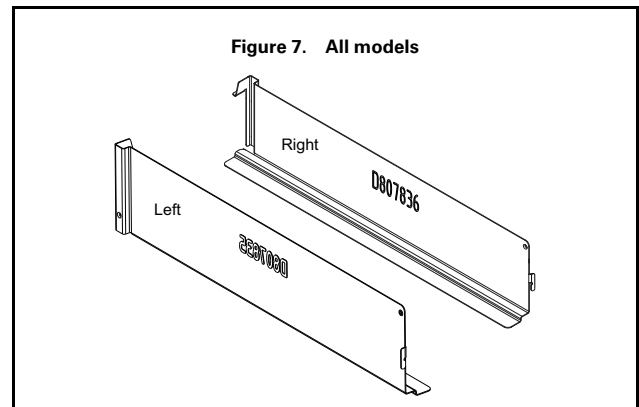
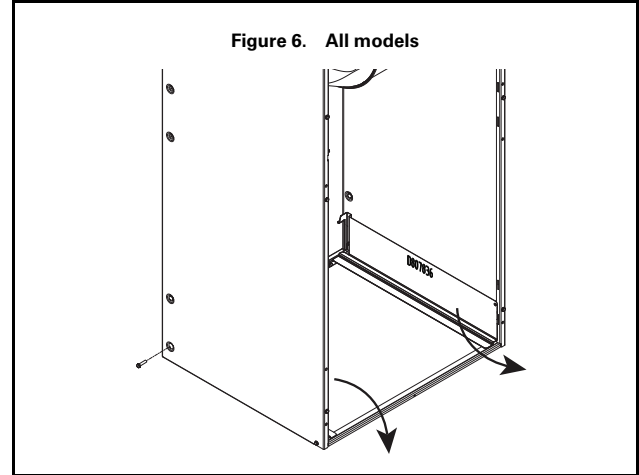

7. Rotate the unit into the downflow orientation.
8. Pre-drill two clearance holes in the cabinet at dimples located below the location the screws were removed for the coil support brackets. There is one hole per side. See location of holes.
9. Replace the center horizontal bracket removed in Step 3. Use the screws retained from Step 3 to attach.
10. Place coil support brackets into the lower set of slots and rotate into place. Push downward to lock into place.
11. Secure each bracket with a screw that were previously removed.

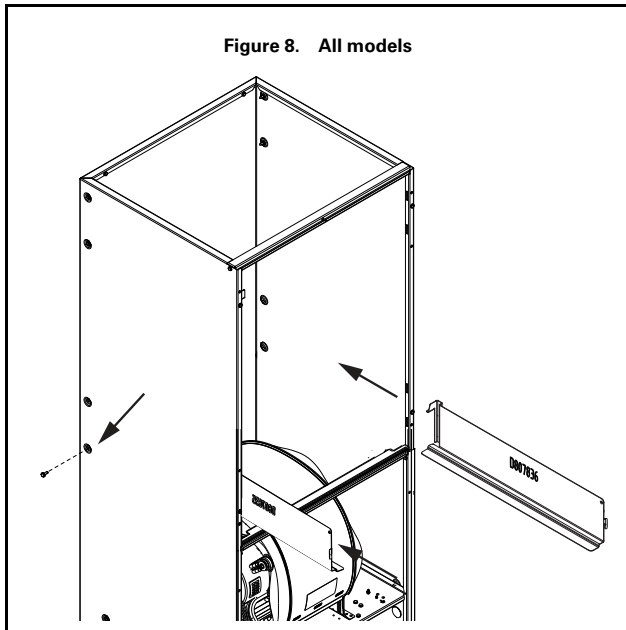

Figure 8. All models

12. Slide the coil assembly back into the air handler cabinet as shown.

13. Remove the appropriate knock out for the condensate piping.

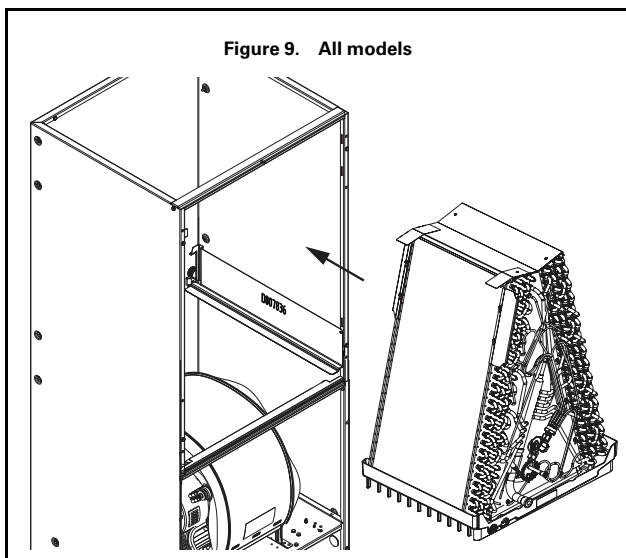

Figure 9. All models

14. Replace all panels.

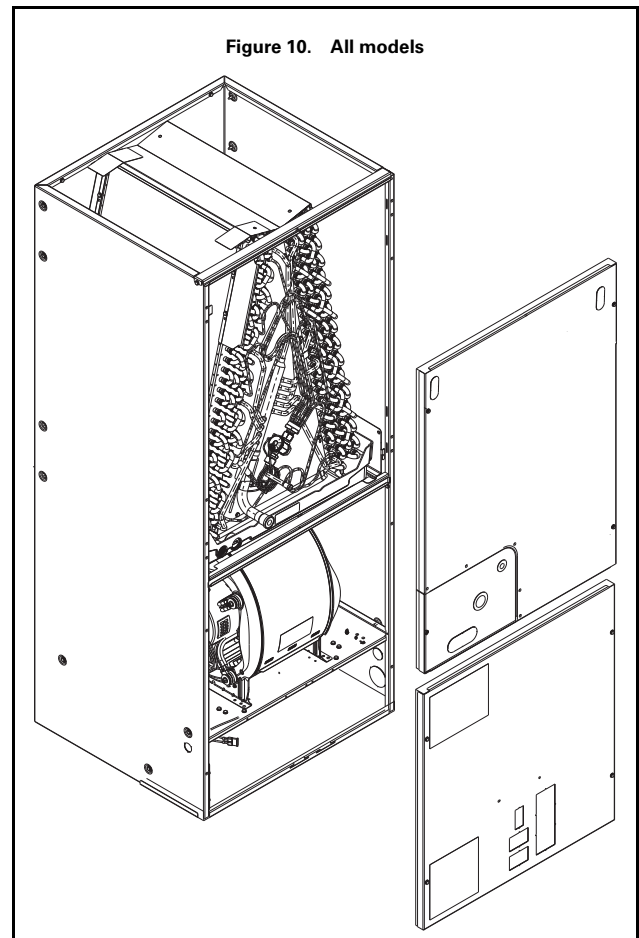

Figure 10. All models

Horizontal Right

Follow the conversion steps when installing the air handler in horizontal right configuration.

1. Remove the front panels from the air handler. The coil and line set panel do not need to be separated.
2. Remove the fasteners on both sides of the coil. Retain the coil retaining brackets and screws.
3. Remove the two screws holding the center horizontal bracket and rotate out of place. Retain parts.

Coil Conversion Instructions

Figure 11. All models

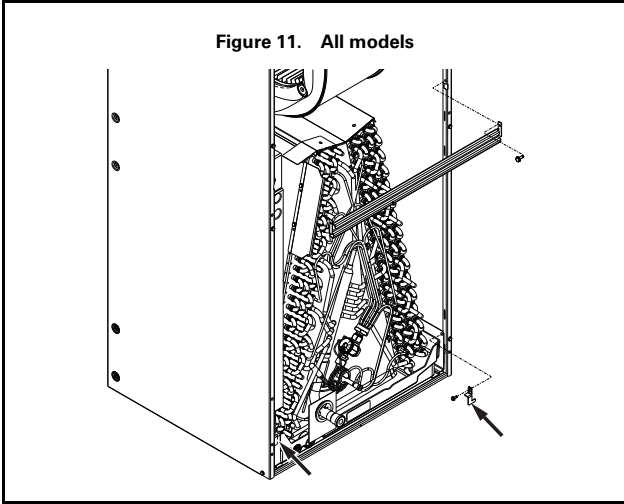

4. Make note of the horizontal drain pan orientation (up/down).
5. Slide the coil assembly out.

Figure 12. All models

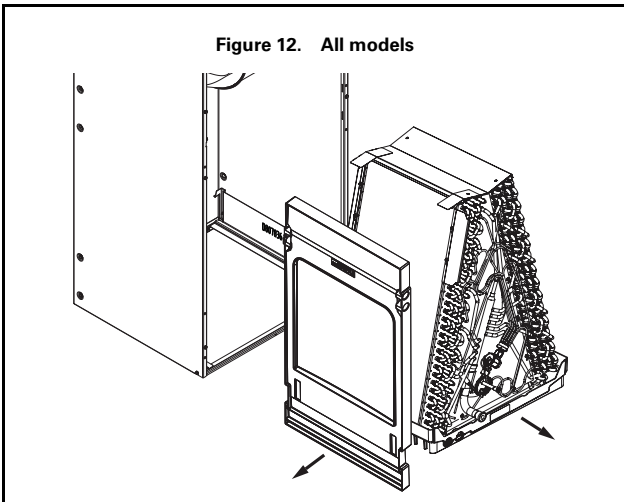

Important: For Horizontal Right applications, ON SOME MODELS the top panel assembly of the coil must be rotated for proper condensate management.

6. On the right side of the top baffle, position a flathead tip underneath the top baffle flange and pivot the screwdriver downward to release the front tab as shown below.
7. Repeat for right rear tab to release top baffle assembly from coil.

Figure 13. All models

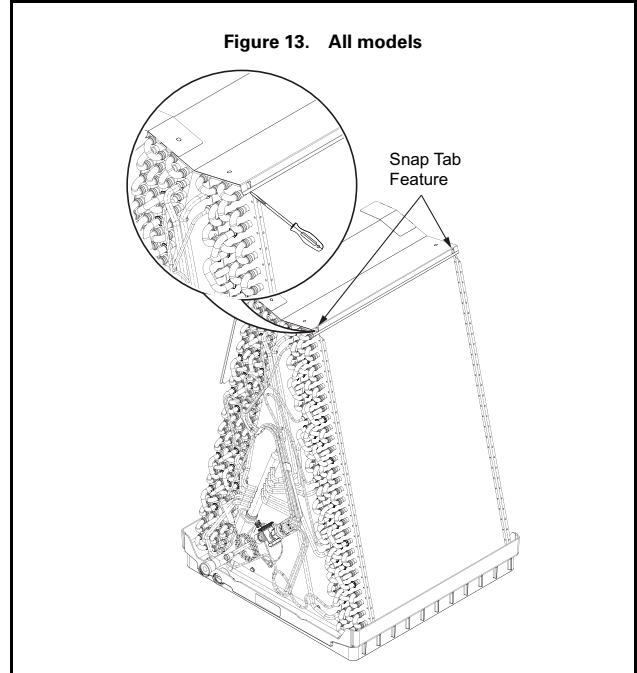

8. Rotate 180 degrees and snap all four corner tabs to lock in place.
9. Remove left side water diverter brackets and screws and reinstall on the right side.

The coil slabs are different and the mount hole locations will vary. See the illustrations on the following pages that correspond to the unit tonnage to see the correct mounting position of the water diverter bracket.

Important: The water diverter brackets are not symmetrical and will vary by tonnage.

Figure 14. All models

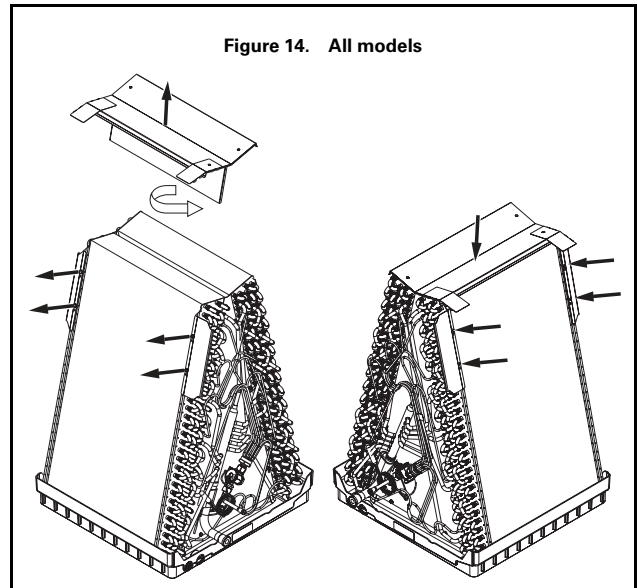

Figure 15. TEM6A0B24H21SCA, TEM6A0B30H21SCA

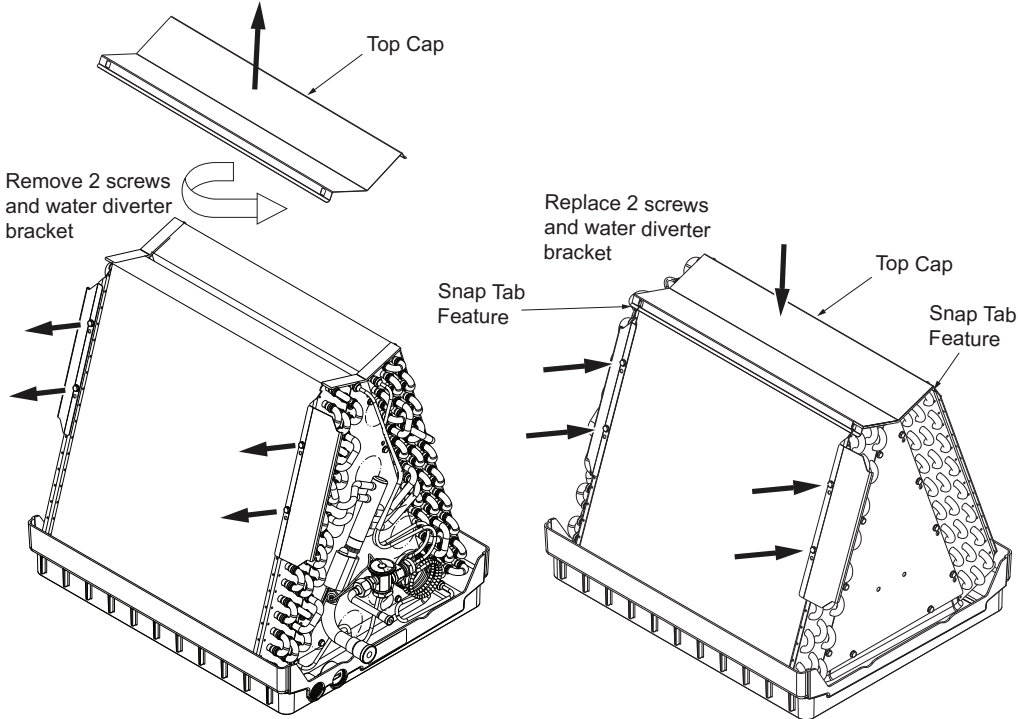
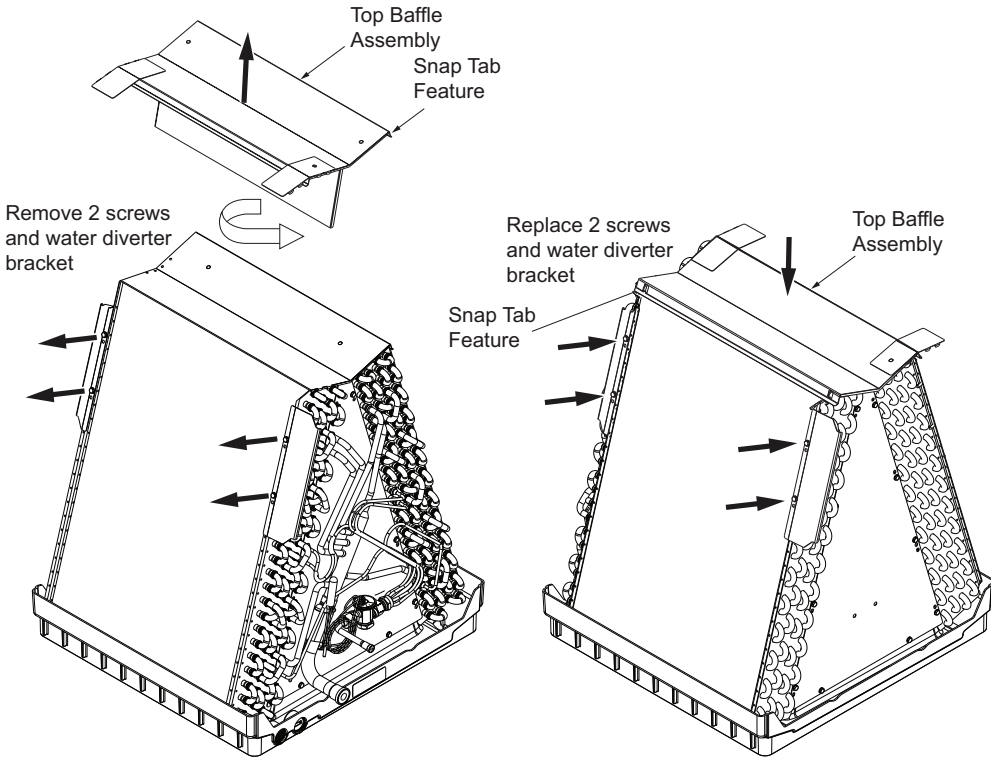
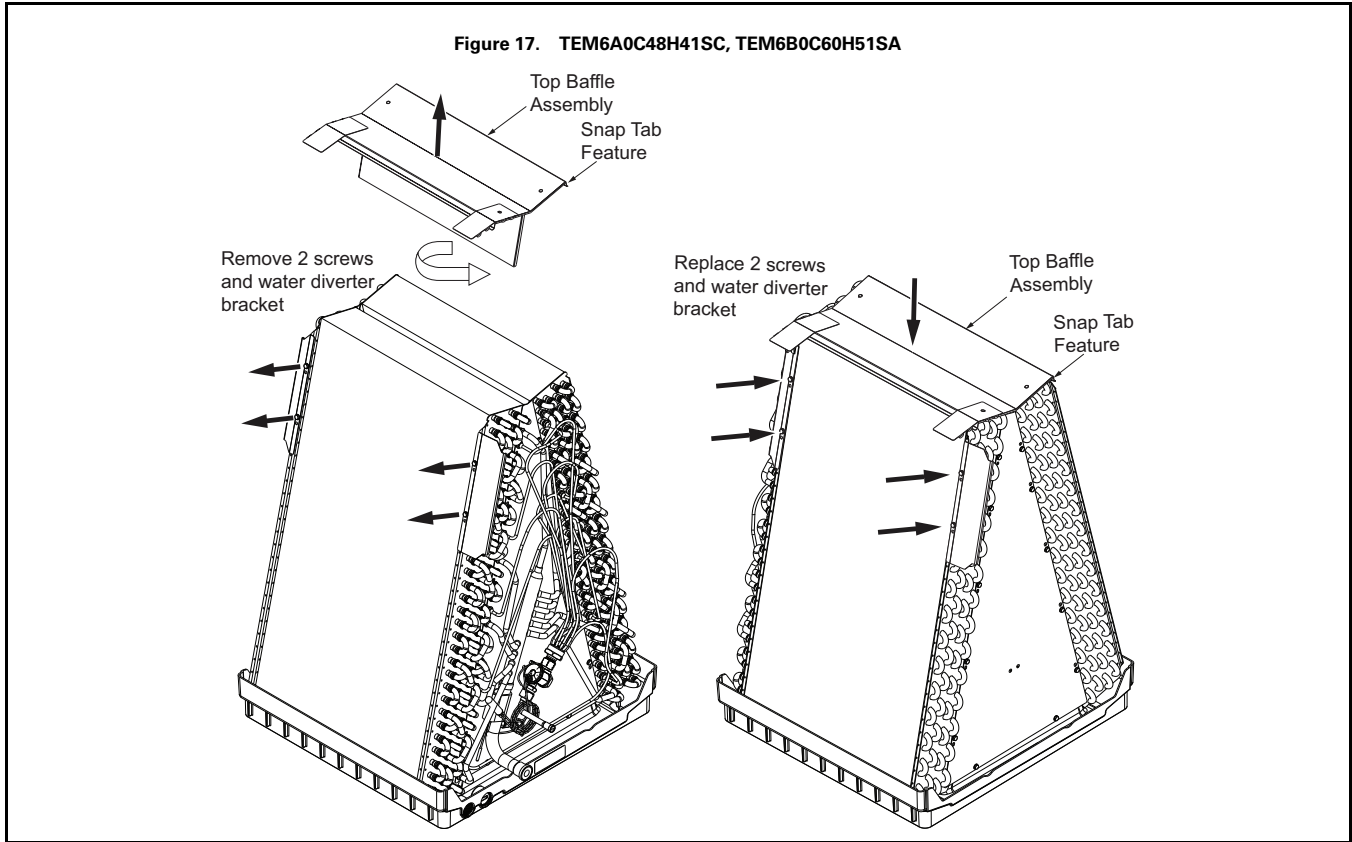

Figure 16. TEM6A0C36H31SC, TEM6A0C42H41SC



Coil Conversion Instructions



10. Relocate the horizontal drain pan from the left side of the coil to the right side.

11. Remove the drain pan support bracket. Do not discard. Remove the two drain plugs from the front of the drain pan and insert them in the drains at the rear of the drain pan.

Important: When reinstalling coil in Step 13, it is important that the coil corner locks in place under the tab in the side bracket to support the coil weight horizontally.

12. Reinstall the drain pan support bracket. The bracket should be located between the two drain plugs as shown.

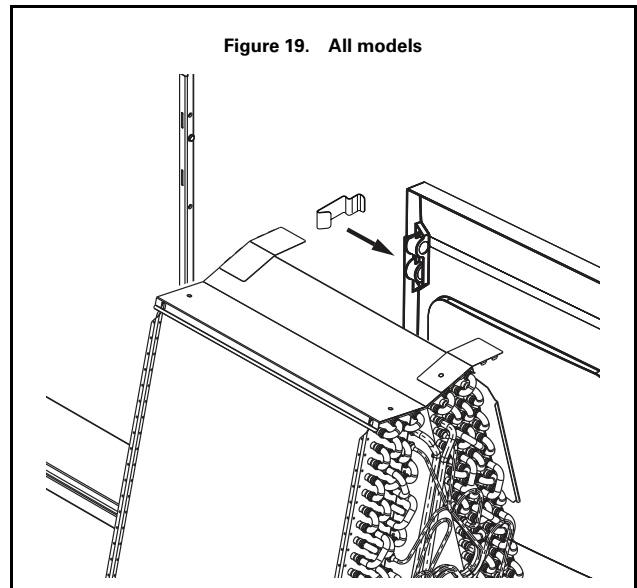
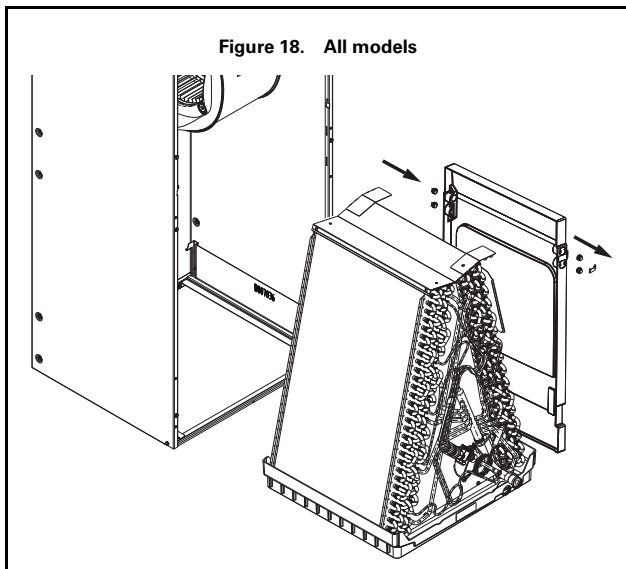

13. Slide the coil assembly back into the air handler cabinet.

Important: Make sure that the coil corner locks in place under the tab in the side left bracket to support the coil weight in the horizontal right position.

14. Replace the center horizontal bracket using screws removed earlier in Step 3.
15. Replace the two coil retaining brackets removed in a previous step.
16. Replace all panels.

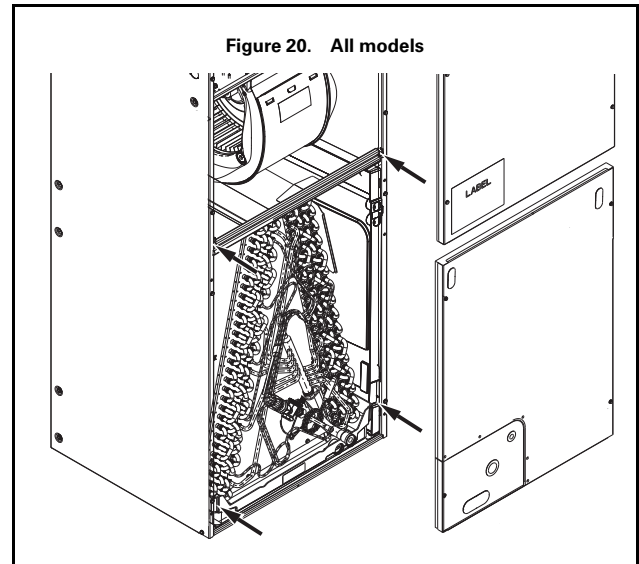

Checkout Procedures

The final phase of the installation is the system Checkout Procedures. The following list represents the most common items covered in a Checkout Procedure. Confirm all requirements in this document have been met.

<ul style="list-style-type: none"><input type="checkbox"/> All wiring connections are tight and properly secured.<input type="checkbox"/> Voltage and running current are within limits.<input type="checkbox"/> All refrigerant lines (internal and external to equipment) are isolated, secure, and not in direct contact with each other or structure.<input type="checkbox"/> All braze connections have been checked for leaks. A vacuum of 350 microns provides confirmation that the refrigeration system is leak free and dry.<input type="checkbox"/> Final unit inspection to confirm factory tubing has not shifted during shipment. Adjust tubing if necessary so tubes do not rub against each other or any component when unit runs.<input type="checkbox"/> Ductwork is sealed and insulated.<input type="checkbox"/> All drain lines are clear with joints properly sealed. Pour water into drain pan to confirm proper drainage. Provide enough water to ensure drain trap is primed.	<ul style="list-style-type: none"><input type="checkbox"/> Supply registers and return grilles are open, unobstructed, and air filter is installed.<input type="checkbox"/> Indoor blower and outdoor fan are operating smoothly and without obstruction.<input type="checkbox"/> Indoor blower motor set on correct speed setting to deliver required CFM. "Blower and fan set screws are tight."<input type="checkbox"/> Cover panels are in place and properly tightened.<input type="checkbox"/> For gas heating systems, manifold pressure has been checked and all gas line connections are tight and leak free.<input type="checkbox"/> For gas heating systems, flue gas is properly vented.<input type="checkbox"/> System functions safely and properly in all modes.<input type="checkbox"/> Owner has been instructed on use of system and given manual.
--	---

About Trane and American Standard Heating and Air Conditioning

Trane and American Standard create comfortable, energy efficient indoor environments for residential applications. For more information, please visit www.trane.com or www.americanstandardair.com.



The manufacturer has a policy of continuous data improvement and it reserves the right to change design and specifications without notice. We are committed to using environmentally conscious print practices.