

# Installation and Operations Manual

## Communicating / 24 Volt Control Convertible Air Handlers 2 – 5 Ton

TEM8A0B24V21DC  
TEM8A0B30V31DC  
TEM8A0C36V31DC  
TEM8A0C42V41DC  
TEM8A0C48V41DC  
TEM8B0C60V51DA

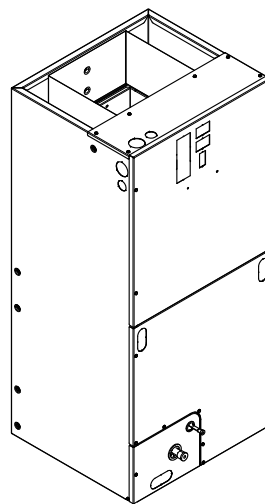
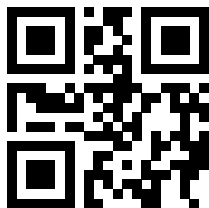

*The TEM8 series air handler is designed for installation in a closet, utility room, alcove, basement, crawlspace or attic. These versatile units are applicable to air conditioning and heat pump applications. Several models are available to meet the specific requirements of the outdoor equipment. Field installed electric resistance heaters are available.*

### **▲ SAFETY WARNING**

Only qualified personnel should install and service the equipment. The installation, starting up, and servicing of heating, ventilating, and air-conditioning equipment can be hazardous and requires specific knowledge and training. Improperly installed, adjusted or altered equipment by an unqualified person could result in death or serious injury. When working on the equipment, observe all precautions in the literature and on the tags, stickers, and labels that are attached to the equipment.

# SAFETY SECTION

**Important:** This document contains a wiring diagram, a parts list, and service information. This is customer property and is to remain with this unit. Please return to service information pack upon completion of work.

**Important:** These instructions do not cover all variations in systems nor provide for every possible contingency to be met in connection with the installation. Should further information be desired or should particular problems arise which are not covered sufficiently for the purchaser's purposes, the matter should be referred to your installing dealer or local distributor.

## ⚠ WARNING

### HAZARDOUS VOLTAGE!

Failure to follow this Warning could result in property damage, severe personal injury, or death.

Disconnect all electric power, including remote disconnects before servicing. Follow proper lockout/tagout procedures to ensure the power cannot be inadvertently energized.

## ⚠ CAUTION

### GROUNDING REQUIRED!

Failure to inspect or use proper service tools may result in equipment damage or personal injury. Reconnect all grounding devices. All parts of this product that are capable of conducting electrical current are grounded. If grounding wires, screws, straps, clips, nuts, or washers used to complete a path to ground are removed for service, they must be returned to their original position and properly fastened.

## ⚠ WARNING

### LIVE ELECTRICAL COMPONENTS!

Failure to follow this Warning could result in property damage, severe personal injury, or death.

Follow all electrical safety precautions when exposed to live electrical components. It may be necessary to work with live electrical components during installation, testing, servicing, and troubleshooting of this product.

## ⚠ WARNING

### PRESSURIZED REFRIGERANT!

Failure to follow this Warning could result in personal injury

System contains oil and refrigerant under high pressure. Recover refrigerant to relieve pressure before opening the system. Do not use non-approved refrigerants or refrigerant substitutes or refrigerant additives.

## ⚠ CAUTION

### SHARP EDGE HAZARD!

Failure to follow this Caution could result in property damage or personal injury.

Be careful of sharp edges on equipment or any cuts made on sheet metal while installing or servicing.

## ⚠ CAUTION

### HAZARDOUS VAPORS!

Failure to follow this caution could result in property damage or personal injury.

Equipment corrosion damage. To prevent shortening its service life, the air handler should not be used during the finishing phases of construction or remodeling. The low return air temperatures can lead to the formation of condensate. Condensate in the presence of chlorides and fluorides from paint, varnish, stains, adhesives, cleaning compounds, and cement creates a corrosive condition which may cause rapid deterioration of the cabinet and internal components.

## ⚠ CAUTION

### COIL IS PRESSURIZED!

- Coil is pressurized with approximately 8–12 psi dry air and factory checked for leaks.
- Carefully release the pressure by removing the rubber plug on the liquid line.
- If no pressure is released, check for leaks.

## ⚠ WARNING

### SAFETY HAZARD!

This appliance is not to be used by persons (including children) with reduced physical, sensory, or mental capabilities, or lack of experience and knowledge, unless they have been given supervision or instruction.

**⚠ WARNING****SAFETY HAZARD!**

Children should be supervised to ensure that they do not play with the appliance.

**⚠ WARNING****WARNING!**

This product can expose you to chemicals including lead, which are known to the State of California to cause cancer and birth defects or other reproductive harm. For more information go to [www.P65Warnings.ca.gov](http://www.P65Warnings.ca.gov).

**Important:** Installation of this unit shall be made in accordance with the National Electric Code, NFPA No. 90A and 90B, and any other local codes or utilities requirements.

**Important:** Air handlers do not require repositioning of the coil or drain pan for upflow or horizontal left applications. See the downflow and horizontal right installation sections for application instructions.

**Note:** Air handlers have been evaluated in accordance with the Code of Federal Regulations, Chapter XX, Part 3280 or the equivalent. "SUITABLE FOR MOBILE HOME USE."

**Note:** Condensation may occur on the surface of the air handler when installed in an unconditioned space. When units are installed in unconditioned spaces, verify that all electrical and refrigerant line penetrations on the air handler are sealed completely.

**Note:** The manufacturer recommends installing ONLY A.H.R.I approved, matched indoor and outdoor systems. Some of the benefits of installing approved matched indoor and outdoor split systems are maximum efficiency, optimum performance, and the best overall system reliability.

**Features****Table 1. Standard Features**

- COMMUNICATING OR 24 VOLT CONTROL
- MULTI-POSITION UPFLOW, DOWNFLOW, HORIZONTAL LEFT AND HORIZONTAL RIGHT
- PAINTED FINISH ON GALVANIZED STEEL EXTERIOR WITH FULLY INSULATED CABINET THAT MEETS R4.2 VALUE
- STURDY POLYCARBONATE DRAIN PANS
  - The TEM air handler has factory installed drain pans and is shipped for upflow and horizontal left applications
- 208/230 VAC OPERATION
- VARIABLE-SPEED DIRECT DRIVE BLOWER.
- FACTORY INSTALLED R-410A THERMAL EXPANSION VALVE
- ALL ALUMINUM COIL
- BOTTOM RETURN
- MEETS THE MINIMUM LEAKAGE REQUIREMENTS FOR THE FLORIDA AND CALIFORNIA BUILDING CODES

**Table 2. Optional Accessories**

- 4,5,8,10,15,20, and 25 KW SINGLE PHASE ELECTRIC HEATERS
  - Circuit breakers available on single phase 4, 5, 8, 10, 15, 20, and 25 KW heaters
  - Lugs available on single phase 4, 5, 8, and 10 KW heaters
  - Lugs available on three phase 10 and 15 KW heaters
- SINGLE POINT POWER ENTRY KIT (for 15 and 20 KW heaters)
- SUPPLY DUCT FLANGE KIT
- DOWNFLOW SUB-BASE KITS - TAYBASE185, TAYBASE235, TAYBASE260
- SLIM FIT FILTER BOX KIT — BAYSF1185AAA, BAYSF1235AAA, BAYSF1265AAA

# Table of Contents

Installation Instructions.....	5	Outline Drawing .....	19
Sequence of Operation .....	7	Heater Pressure Drop Table .....	20
Abbreviations .....	7	Subcooling Adjustment .....	20
Electrical – Low Voltage .....	8	Subcooling Adjustment for TEM8A0C48V41 & TEM8B0C60V51.....	20
Wiring D806011P02revA.....	11	Coil Conversion Instructions.....	21
Performance and Electrical Data .....	12	Checkout Procedures .....	27
Minimum Airflow CFM .....	18		

# Installation Instructions

## 1. Unpacking

Carefully unpack the unit and inspect the contents for damage. If any damage is found at the time of delivery, proper notification and claims should be made with the carrier.

Check the rating plate to assure model number and voltage, plus any kits match with what you ordered. The manufacturer should be notified within 5 days of any discrepancy or parts shortage.

## 2. Location

The air handler should be centrally located and may be installed in a closet, alcove, utility room, basement, crawl space or attic. Minimum clearances must be met.

The unit should be installed in a level position to ensure proper condensation drainage. Up to an additional 1/4" rise over the width or depth of the unit is allowed to create additional sloping towards the drain. Unit must be positioned between level and 1/4" rise, sloping toward the drain connections.

When the unit is installed in a closet or utility room, the room should be large enough, and have an opening to allow replacement of the unit. All servicing is done from the front and a clearance of 21" is needed for service unless the closet door aligns with the front of the air handler.

If you are installing the unit in an unconditioned space such as an attic or crawl space, you must ensure that the area provides sufficient air circulation to prevent moisture collection on the cabinet during high dew point conditions. A drain pan must be installed under the entire unit when it is installed in or above a finished ceiling or in an unconditioned space.

## 3. Duct Work

The duct work should be installed in accordance with the NFPA No. 90A "Installation of Air Conditioning and Ventilating systems" and No. 90B "Residential Type Warm Air Heating and Air Conditioning Installation."

The duct work should be insulated in accordance with the applicable requirements for the particular installation as required by HUD, FHA, VA the applicable building code, local utility or other governing body.

## 4. Condensate Drain

The unit is supplied with primary and auxiliary condensate drains that have 3/4" NPT connections. The primary drain must be trapped outside the unit and piped in accordance with applicable building codes.

The figure shows the operation of a properly

designed trap under normal operating conditions when the blower is running and the condensate is draining. Note the difference in height of the water column must at least equal the normal negative static pressure existing during operation between the cooling coil and blower. It is advisable to have the difference in water column height somewhat greater than the normal maximum operating static to allow for greater static caused by dirty filters or for the bounce of the water column on start up.

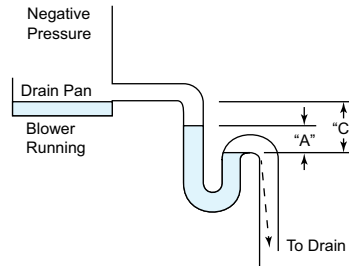

Proper operation of condensate trap under normal operating conditions.

"A" height of water column equals negative static pressure existing in system.

"C" dimension should at least equal two times the maximum negative static pressure that can occur in system.

Do not reduce the drain line size less than the connection size on the drain pan. Condensate should be piped to an open drain or to the outside. All drains must pitch downward away from the unit a minimum of 1/4" per foot of line to ensure proper drainage.

**Important:** If cleanout Tee is used, stand pipe must be sealed/capped.

**Important:** If a vent Tee is used, it must be downstream from the trap.

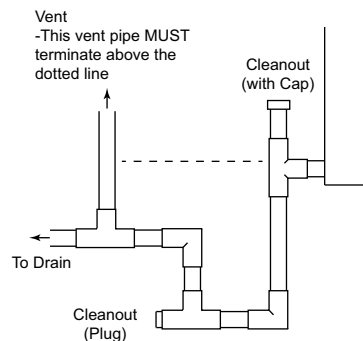

Insulate the primary drain line to prevent sweating where dew point temperatures may be met. (Insulation is optional depending on climate and application needs.)

# Installation Instructions

## 5. Refrigerant Piping

Refrigerant piping external to the unit shall be sized in accordance with the instructions of the manufacturer of the outdoor equipment.

## 6. Metering Device

All units are shipped and installed with an internally-checked, non-bleed TXV designed for air conditioning or heat pump operation. Some outdoor models may require a start assist kit. See outdoor unit for more information.

## 7. Blower

This unit is supplied with a variable speed motor with a direct drive blower wheel which can obtain various air flows. The unit is shipped with factory set cooling and heating air flows. Performance tables are available for additional airflow settings. Disconnect all power to the unit before making any adjustments to the airflow settings. Be sure to check the air flow and the temperature drop across the evaporator coil to ensure sufficient air flow.

## 8. Airflow Adjustment

**Note:** A CDA tool may be plugged into the TEM8 control board and used to configure or monitor the system

## 9. Indoor Blower Timing

**Table 3. Delay Options**

The blower delay profile is to be configured for heating and cooling modes of operation. There are 4 blower off delay options	
Option 1	90 seconds at 100% air flow
Option 2	No delay
Option 3	180 seconds at 50% air flow
Option 4	Enhanced Mode

**Figure 1. Enhanced Mode**

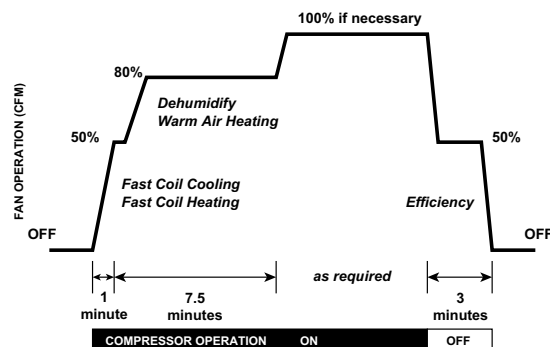

## 10. Wiring

Consult all schematic and pictorial wiring diagrams of this unit and the outdoor equipment to determine compatibility of wiring connections and to determine specific requirements.

All field wiring to the air handler should be installed in accordance with the latest edition of the National

Electric Code NFPA No. 70 and any local codes. Check rating plates on unit for rated volts, minimum circuit ampacity and maximum over current protection. Supply circuit power wiring must be 75 degree C (167 degree F) minimum copper conductors only. Copper supply wires shall be sized to the National Electric Code or local code requirements, whichever is more stringent.

The unit is shipped wired for 230/240 Volt AC 60 HZ 1 Phase Operation. If the unit is to be operated at 208 VAC 60HZ, follow the instructions on the indoor unit wiring diagram to change the low voltage transformer to 208 VAC operation (Ensure unit is properly grounded).

Class 2 low voltage control wiring should not be run in conduit with power wiring and must be separated from power wiring unless class 1 wire with proper voltage rating is used.

Low voltage control wiring should be 18 Awg, color coded (105 degree C minimum). For lengths longer than 100ft., 16 Awg wire should be used. Make certain that separation of control wiring and power wiring has been maintained.

## 11. Air Filter

To protect the coil, blower and other internal parts from excessive dirt and dust an air filter must be installed before air enters the evaporator coil. A remote filter must be installed. Consult the filter manufacturer for proper sizing and maximum velocity requirements.

**Important:** Air filters shall meet the test requirements in UL 900.

## 12. Operational and Checkout Procedures

To obtain proper performance, all units must be operated and charge adjustments made in accordance with procedures found in the Service Facts document of the outdoor unit. After installation has been completed, it is recommended that the entire system be checked against the checkout list located at the back of this document. See "Checkout Procedures," p. 27.

## 13. Maintenance

The system air filter(s) should be inspected, cleaned or replaced at least monthly. Make certain that the access panels are replaced and secured properly before placing the unit back in operation. This product is designed for dependable service; however, periodic maintenance should be scheduled and conducted by trained professional service personnel. This service should be conducted at least annually and should include testing and inspection of electrical and refrigerant components, flushing of condensate drain, and repriming of condensate trap. The heat transfer surface should be cleaned. The blower motor is permanently lubricated for normal operating conditions.

# Sequence of Operation

## Abbreviations

- AFC = Airflow Control

**Note:** Use variable speed outdoor Sequence of Operation in conjunction with the TEM8 Sequence of Operation.

The installing and servicing technician should have an understanding of the sequence of operation to be able to properly setup and diagnose functions of the air handler.

**See unit, electric heat, and field wiring diagrams for additional information.**

## Continuous Fan

**Important:** If the indoor air exceeds 60% relative humidity or simply feels uncomfortably humid, it is recommended that the indoor fan only be used in the AUTO mode.

1. When a fan request is received from the thermostat, the AFC sends a command to the serial communicating blower motor to run. Airflow can be adjusted through the thermostat.
2. Humidity Control – When enabled at the thermostat, this feature will disable any blower off delays and disable continuous fan mode when the humidity is above the dehumidification setpoint. This will help prevent coil condensation from being evaporated back into the air stream.

## Cooling Mode

1. When a request for 1st stage cooling is received, the AFC sends a command to the serial communicating blower motor to run at 1st stage cooling airflow. (Delay profiles from the thermostat may change blower motor timing and actual airflow demand)
2. When a request for 2nd stage cooling is received, the AFC sends a command to the serial communicating blower motor to run at 100 % cooling airflow.
3. When a request for cooling is removed, the AFC will turn off the blower motor after any user selected fan-off delays have expired.

**Note:** Delay profiles from the thermostat may change blower motor timing and actual airflow demand.

## Heat pump (compressor only)

1. When a request for 1st stage heat is received, the AFC sends a command to the serial communicating blower motor to run at 1st stage heating airflow.

2. Humidifier contacts close on demand from thermostat.
3. When a request for 2nd stage mechanical heat is received, the AFC sends a command to the serial communicating blower motor to run at 100 % heating airflow.
4. When a request for heat pump is removed, the AFC will turn off the blower motor after any user selected fan-off delays have expired.

**Note:** Delay profiles from the thermostat may change blower motor timing and actual airflow demand.

## Electric Heat

1. When a request for electric heat is received, the AFC will energize the on board 24 volt relays per the amount of heat requested from the thermostat and the size of the heater installed.
2. The AFC sends a command to the serial communicating blower motor to run proper airflow and close the blower interlock relay on the EHC.

## Defrost

1. The OD unit will initiate defrost and send a message to the AFC.
2. Electric or hydronic heat will be energized to help temper the air.

## Unit Test Mode

Unit Test Mode will exit if any demand is given to the unit.

To enter Unit Test Mode:

1. Set System Switch on comfort control to Off.
2. Scroll down to the Unit Test selection and push the "Enter" button.

## Sequence of Unit Test Mode (OD unit is not energized during the Unit Test Mode)

1. AFC energizes the blower at 50% and then continues to ramp until it reaches 100% cooling airflow.
2. Humidifier contacts close when the blower starts.
3. AFC energizes the W relays in 10 second intervals. The blower remains at 100% air flow.
4. All relays de-energize and the blower shuts off five seconds after the last bank of heat is energized.

**Note:** If an error occurs during the Unit Test Mode, the Fault LED will flash a code and continue the test.

# Electrical – Low Voltage

**Table 4. Low Voltage Maximum Wire Length**

<p>The Low Voltage Maximum Wire Length table defines the size and combined total maximum length of the low voltage wiring from the outdoor unit, to the indoor unit, and to the thermostat.</p> <p><b>Note:</b> <i>The use of color coded low voltage wire is recommended to simplify connections between the outdoor unit, the control, and the indoor unit.</i></p>	Control Wire – Communicating	
	WIRE SIZE	MAX. WIRE LENGTH
	18 AWG	500 FT. Combined
	Control Wire – 24 Volt	
	WIRE SIZE	MAX. WIRE LENGTH
	18 AWG	100 FT. Combined

**Table 5. Humidifier and External Switch**

When connecting a humidifier or an external switch to the air handler, locate the harness(es) in the doc pack. The plug on the harness will plug into the AFC control board.

Humidifier Harness

External Switch Harness

J5 External Switch

J12 Humidifier

AFC

**Table 6. Low Voltage Hook-up Instructions**

**Note:** *Strain relief must be provided on the inside of the air handler cabinet for the low voltage wiring. Field supplied thermostat wired may be wire tied as a bundle to the existing strain relieved low voltage pigtail leads in the air handler unit.*

- Route control wiring to unit. Remove the external sheathing of the wiring approximately 5".

5"



### Communicating Controls Wiring Diagram

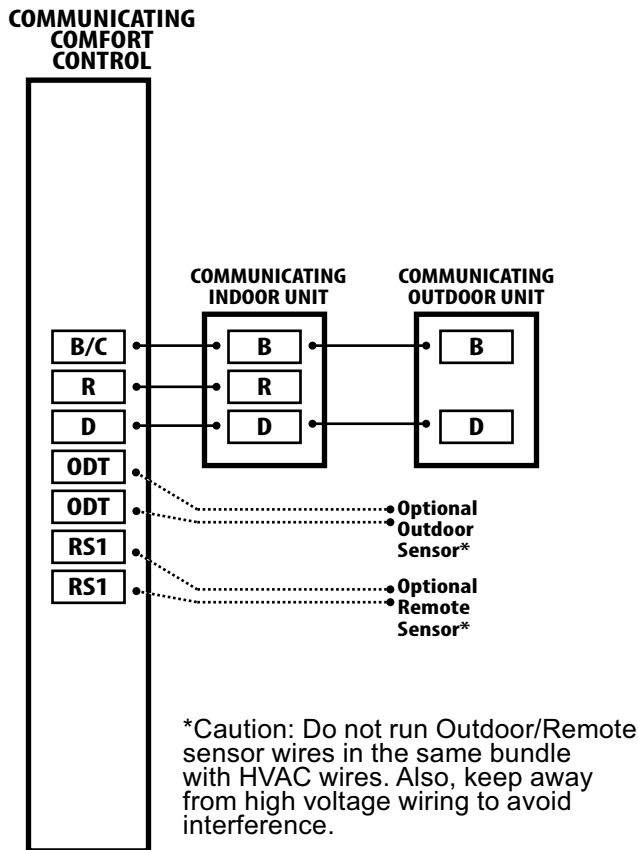

### 1 OR 2 STAGE COOLING WITH TEM8 MODEL VARIABLE SPEED AIR HANDLER

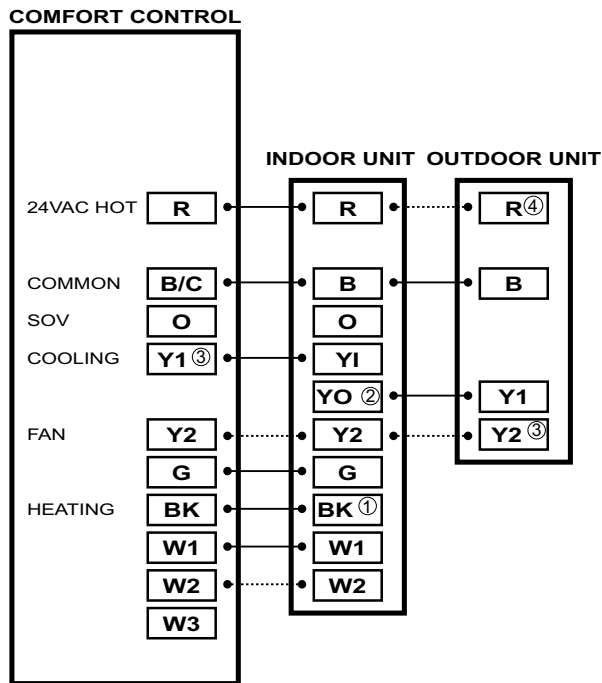

**NOTES:**

1. Cut the BK jumper on the AFC when using the BK functionality from the thermostat.
2. Y1 and YO connections must be made as shown for external switch functionality. (See table 5) Can be used for condensate overflow switch as well as other functions. Configure this functionality from the AFC seven segment display.
3. When using the BK feature from the comfort control, the Y1 & Y2 inputs to the AFC are for the seven segment display only. The BK feature has 100% control over air flow.
4. Y2 connections at outdoor unit at required only for two stage units.

**1 OR 2 STAGE HEAT PUMP WITH TEM8 VARIABLE SPEED AIR HANDLER**

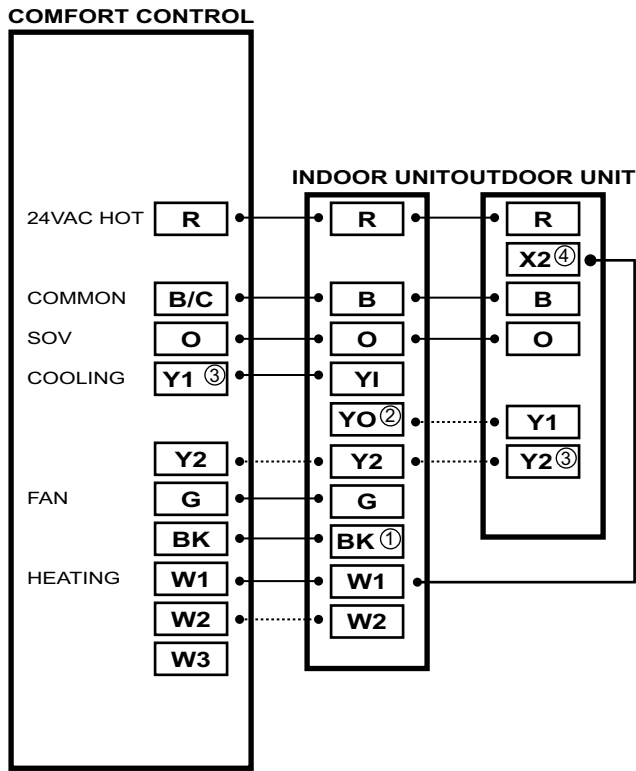

**NOTES:**

1. Cut the BK jumper on the AFC when using the BK functionality from the thermostat.
2. Y1 and YO connections must be made as shown for external switch functionality. (See table 5) Can be used for condensate overflow switch as well as other functions. Configure this functionality from the AFC seven segment display.
3. Connection to X2 is not required when using the 402, 624, 824, or relay panel controls.
4. When using the BK feature from the comfort control, the Y1 & Y2 inputs to the AFC are for the 7 segment display only. The BK feature has 100% control over air flow.



# Performance and Electrical Data

TEM8A0B24V21DC AIRFLOW PERFORMANCE CONSTANT CFM MODE / CONSTANT TORQUE MODE													
OUTDOOR MULTIPLIER (TONS)	COOLING AIRFLOW SETTING	AIRFLOW POWER	EXTERNAL STATIC PRESSURE (Constant CFM / Constant Torque)				HEATING AIRFLOW SETTING	AIRFLOW POWER	EXTERNAL STATIC PRESSURE				
			0.1	0.3	0.5	0.7			0.9	0.1	0.3	0.5	0.7
1.5 tons	290 CFM/ton	CFM Watts	430 / 538 50 / 39	430 / 415 75 / 48	430 / 264 95 / 43	430 / NA 110 / NA	290 CFM/ton	CFM Watts	434 64	419 96	419 96	403 130	384 167
	350 CFM/ton	CFM Watts	520 / 620 60 / 53	520 / 514 90 / 64	520 / 398 120 / 61	520 / NA 135 / NA	350 CFM/ton	CFM Watts	521 44	512 77	514 112	500 153	485 196
	400 CFM/ton	CFM Watts	590 / 688 75 / 67	590 / 593 105 / 80	590 / 493 140 / 80	590 / NA 160 / NA	400 CFM/ton	CFM Watts	595 56	589 91	595 127	584 173	573 222
	450 CFM/ton	CFM Watts	670 / 758 85 / 85	670 / 671 125 / 100	660 / 581 160 / 102	660 / NA 190 / NA	450 CFM/ton	CFM Watts	668 71	667 107	675 145	668 196	660 250
	290 CFM/ton	CFM Watts	570 / 670 60 / 63	570 / 573 90 / 76	570 / 469 125 / 75	570 / NA 165 / NA	290 CFM/ton	CFM Watts	575 53	569 87	573 123	561 167	549 215
2 tons	350 CFM/ton	CFM Watts	690 / 781 85 / 91	690 / 696 120 / 107	690 / 609 160 / 110	690 / 518 259 / NA	350 CFM/ton	CFM Watts	693 76	693 113	702 152	696 204	689 259
	400 CFM/ton	CFM Watts	790 / 875 110 / 122	790 / 798 150 / 140	790 / 720 195 / 145	780 / 639 301 / 115	400 CFM/ton	CFM Watts	791 103	795 143	805 184	803 240	798 301
	450 CFM/ton	CFM Watts	890 / 971 145 / 161	890 / 899 185 / 181	880 / 827 235 / 189	880 / 754 347 / 184	450 CFM/ton	CFM Watts	889 138	895 181	902 226	899 284	891 347
	290 CFM/ton	CFM Watts	720 / 823 90 / 104	720 / 741 140 / 120	710 / 659 170 / 124	710 / 573 220 / 115	290 CFM/ton	CFM Watts	717 82	718 120	728 159	723 212	717 269
	350 CFM/ton	CFM Watts	870 / 963 140 / 157	860 / 892 182 / 177	873 / 819 235 / 185	860 / 746 280 / 180	350 CFM/ton	CFM Watts	865 128	871 170	879 214	876 272	869 335
2.5 tons †	390 † CFM/ton	CFM Watts	958 / 1075 147 / 170	975 / 1000 203 / 195	946 / 878 269 / 211	871 / 711 342 / 197	390 † CFM/ton	CFM Watts	958 138	979 192	957 257	878 336	822 406
	400 CFM/ton	CFM Watts	980 / 1100 157 / 181	993 / 1019 213 / 205	958 / 889 280 / 219	875 / 714 357 / 205	400 CFM/ton	CFM Watts	980 146	998 202	969 268	882 351	821 422
	450 CFM/ton	CFM Watts	980 / 1100 157 / 181	993 / 1019 213 / 205	958 / 889 280 / 219	875 / 714 357 / 205	450 CFM/ton	CFM Watts	980 146	998 202	969 268	882 351	821 422

- † Factory Setting
- Status LED will blink once per 100 CFM requested. In torque mode, actual airflow may be lower.
- To prevent water blow-off, the max airflow demand allowable is 1000 CFM. If an outdoor multiplier and cooling airflow setting should result in a demand higher than 1000, the AFC will default the demand back to 1000.
- Torque mode will reduce airflow when static is above approximately 0.3" water column.
- All heating modes default to Constant CFM.
- In communicating mode, default CFM/Ton is 400.
- Cooling airflow values are with wet coil, no filter

OUTDOOR MULTIPLIER (TONS)	TEM8A0B30V31DC AIRFLOW PERFORMANCE										CONSTANT CFM MODE / CONSTANT TORQUE MODE													
	EXTERNAL STATIC PRESSURE (Constant CFM / Constant Torque)					HEATING AIRFLOW SETTING					AIRFLOW POWER					EXTERNAL STATIC PRESSURE								
	0.1	0.3	0.5	0.7	0.9	290	350	400	450	290	350	400	450	CFM	Watts	CFM	Watts	CFM	Watts	0.1	0.3	0.5	0.7	0.9
1.5 tons	430/538	430/415	430/264	430/NA	430/NA	290	350	400	450	430/NA	290	350	400	450	419	403	384	384	384	434	419	419	403	384
	50/39	75/48	95/43	110/NA	145/NA	CFM	CFM/ton	CFM	CFM	145/NA	CFM/ton	CFM	CFM	Watts	Watts	130	167	167	34	64	96	130	167	167
	520/620	520/514	520/398	520/NA	510/NA	350	400	450	290	510/NA	350	400	450	521	500	485	485	485	521	512	514	500	485	485
	60/53	90/64	120/61	135/NA	175/NA	CFM/ton	CFM/ton	CFM/ton	CFM/ton	175/NA	CFM/ton	CFM/ton	CFM/ton	44	153	196	196	196	44	77	112	153	196	196
	590/688	590/593	590/493	590/NA	590/NA	400	450	290	568/NA	590/NA	400	450	290	595	584	573	573	573	595	589	595	584	573	573
75/67	105/80	140/80	160/NA	205/NA	CFM	CFM/ton	CFM/ton	CFM/ton	205/NA	CFM/ton	CFM/ton	CFM/ton	56	173	222	222	222	56	91	127	173	222	222	
2 tons	670/758	670/671	660/581	660/NA	660/NA	450	290	568/NA	660/NA	450	290	568/NA	660/NA	668	668	660	660	660	668	667	675	668	660	660
	85/85	125/100	160/102	190/NA	235/NA	CFM/ton	CFM/ton	CFM/ton	235/NA	CFM/ton	CFM/ton	CFM/ton	71	196	250	250	250	71	107	145	196	250	250	250
	570/670	570/573	570/469	570/NA	568/NA	290	350	400	450	568/NA	290	350	400	575	561	549	549	549	575	569	573	561	549	549
	60/63	90/76	125/75	165/NA	215/NA	CFM	CFM/ton	CFM/ton	CFM/ton	215/NA	CFM/ton	CFM/ton	CFM/ton	53	167	215	215	215	53	87	123	167	215	215
	690/781	690/696	690/609	690/518	680/NA	350	400	450	680/NA	680/NA	350	400	450	693	696	689	689	689	693	693	702	696	689	689
85/91	120/107	160/110	210/98	259/NA	CFM/ton	CFM/ton	CFM/ton	259/NA	259/NA	CFM/ton	CFM/ton	CFM/ton	76	204	259	259	259	76	113	152	204	259	259	
2.5 tons	790/875	790/798	790/720	780/639	780/555	400	290	568/NA	780/555	400	290	568/NA	780/555	791	805	798	798	791	795	805	805	803	798	798
	110/122	150/140	195/145	250/137	301/115	CFM	CFM/ton	CFM/ton	301/115	CFM/ton	CFM/ton	CFM/ton	103	184	240	240	240	103	143	184	240	240	240	240
	890/971	890/899	880/827	880/754	880/680	450	290	568/NA	880/680	450	290	568/NA	889	895	892	892	892	889	895	902	895	892	891	891
	145/161	185/181	235/189	295/184	347/184	CFM	CFM/ton	CFM/ton	347/184	CFM/ton	CFM/ton	CFM/ton	138	181	226	226	226	138	181	226	226	284	347	347
	720/823	720/741	710/659	710/573	710/481	290	350	400	450	710/481	290	350	400	717	728	717	717	717	717	82	120	159	212	269
90/104	140/120	170/124	220/115	260/91	CFM	CFM/ton	CFM/ton	260/91	260/91	CFM/ton	CFM/ton	CFM/ton	82	212	269	269	269	82	120	159	212	269	269	
2.5 tons	870/963	860/892	873/819	860/746	850/671	350	400	450	850/671	350	400	450	865	879	869	869	869	865	871	879	876	876	869	869
	140/157	182/177	235/185	280/180	330/161	CFM	CFM/ton	CFM/ton	330/161	CFM/ton	CFM/ton	CFM/ton	128	170	214	214	214	128	170	214	214	272	335	335
	969/1087	985/1011	993/921	992/809	1000/770	390	400	450	1000/770	390	400	450	969	999	1026	1026	1026	969	989	1004	999	999	1026	1026
	143/166	198/191	262/205	329/189	399/187	CFM	CFM/ton	CFM/ton	399/187	CFM/ton	CFM/ton	CFM/ton	134	188	250	250	250	134	188	250	250	323	402	402
	993/1114	1008/1035	1017/943	1015/828	1022/787	400	400	450	1022/787	400	400	450	993	1013	1028	1028	1028	993	1013	1028	1028	1023	1049	1049
152/176	208/200	273/214	341/196	413/194	CFM	CFM/ton	CFM/ton	413/194	CFM/ton	CFM/ton	CFM/ton	142	197	261	261	261	142	197	261	261	335	416	416	
3 tons †	993/1114	1008/1035	1017/943	1015/828	1022/787	450	450	450	1022/787	450	450	450	993	1013	1028	1028	1028	993	1013	1028	1028	1023	1049	1049
	152/176	208/200	273/214	341/196	413/194	CFM	CFM/ton	CFM/ton	413/194	CFM/ton	CFM/ton	CFM/ton	142	197	261	261	261	142	197	261	261	335	416	416
	868/974	884/907	891/826	893/729	894/688	290	350	400	894/688	290	350	400	868	888	901	901	901	868	888	901	901	900	917	917
	111/128	163/156	220/173	281/162	345/162	CFM	CFM/ton	CFM/ton	345/162	CFM/ton	CFM/ton	CFM/ton	103	154	211	211	211	103	154	211	211	277	347	347
	993/1114	1008/1035	1017/943	1015/828	1022/787	350	350	400	1022/787	350	350	400	993	1013	1028	1028	1028	993	1013	1028	1028	1023	1049	1049
152/176	208/200	273/214	341/196	413/194	CFM	CFM/ton	CFM/ton	413/194	CFM/ton	CFM/ton	CFM/ton	142	197	261	261	261	142	197	261	261	335	416	416	
3 tons †	993/1114	1008/1035	1017/943	1015/828	1022/787	390 †	390 †	400	1022/787	390 †	390 †	400	993	1013	1028	1028	1028	993	1013	1028	1028	1023	1049	1049
	152/176	208/200	273/214	341/196	413/194	CFM	CFM/ton	CFM/ton	413/194	CFM/ton	CFM/ton	CFM/ton	142	197	261	261	261	142	197	261	261	335	416	416
	993/1114	1008/1035	1017/943	1015/828	1022/787	400	400	450	1022/787	400	400	450	993	1013	1028	1028	1028	993	1013	1028	1028	1023	1049	1049
	152/176	208/200	273/214	341/196	413/194	CFM	CFM/ton	CFM/ton	413/194	CFM/ton	CFM/ton	CFM/ton	142	197	261	261	261	142	197	261	261	335	416	416
	993/1114	1008/1035	1017/943	1015/828	1022/787	450	450	450	1022/787	450	450	450	993	1013	1028	1028	1028	993	1013	1028	1028	1023	1049	1049
152/176	208/200	273/214	341/196	413/194	CFM	CFM/ton	CFM/ton	413/194	CFM/ton	CFM/ton	CFM/ton	142	197	261	261	261	142	197	261	261	335	416	416	

- † Factory Setting
- Status LED will blink once per 100 CFM requested. In torque mode, actual airflow may be lower.
- To prevent water blow-off, the max airflow demand allowable is 1000 CFM. If an outdoor multiplier and cooling airflow setting should result in a demand higher than 1000, the AFC will default the demand back to 1000.
- Torque mode will reduce airflow when static is above approximately 0.3" water column.
- All heating modes default to Constant CFM.
- In communicating mode, default CFM/Ton is 400.
- Cooling airflow values are with wet coil, no filter

# Performance and Electrical Data

OUTDOOR MULTIPLIER (TONS)	TEM8A0C36V31DC & TEM8A0C42V41DC AIRFLOW PERFORMANCE (Constant CFM / Constant Torque)										CONSTANT CFM MODE / CONSTANT TORQUE MODE														
	COOLING AIRFLOW SETTING					EXTERNAL STATIC PRESSURE (Constant CFM / Constant Torque)					HEATING AIRFLOW SETTING					AIRFLOW POWER					EXTERNAL STATIC PRESSURE				
	290 CFM/ton	350 CFM/ton	400 CFM/ton	450 CFM/ton	290 CFM/ton	0.1	0.3	0.5	0.7	0.9	0.1	0.3	0.5	0.7	0.9	290 CFM/ton	350 CFM/ton	400 CFM/ton	450 CFM/ton	290 CFM/ton	0.1	0.3	0.5	0.7	0.9
2.5 tons	735 / 837	883 / 972	1007 / 1084	1133 / 1198	143 / 177	727 / 702	884 / 849	1016 / 971	1033 / 874	1140 / 1093	700 / 593	882 / 746	1020 / 788	1140 / 919	660 / 415	735 / 59	883 / 82	1007 / 1016	1133 / 1146	290	735	884	1007	1146	660
	59 / 72	82 / 103	109 / 136	143 / 177	192 / 202	96 / 90	124 / 123	154 / 158	204 / 171	246 / 220	138 / 105	170 / 138	223 / 152	269 / 187	215 / 148	59	82	109	143	CFM/ton	727	884	1016	1146	673
	700 / 593	882 / 746	1033 / 874	1140 / 919	143 / 177	881 / 657	1020 / 788	1140 / 919	1210 / 1024	1330 / 845	700 / 593	882 / 746	1020 / 788	1140 / 919	660 / 415	735 / 59	883 / 82	1007 / 1016	1133 / 1146	CFM/ton	727	884	1016	1146	673
	138 / 105	170 / 138	204 / 171	246 / 220	321 / 233	881 / 657	1020 / 788	1140 / 919	1210 / 1024	1330 / 845	138 / 105	170 / 138	204 / 171	269 / 187	215 / 148	59	82	109	143	CFM/ton	727	884	1016	1146	673
	215 / 148	270 / 168	320 / 200	375 / 244	410 / 287	881 / 657	1020 / 788	1140 / 919	1210 / 1024	1330 / 845	138 / 105	170 / 138	204 / 171	269 / 187	215 / 148	59	82	109	143	CFM/ton	727	884	1016	1146	673
3 tons	1057 / 1154	1222 / 1312	1364 / 1426	1522 / 1612	1681 / 1771	1068 / 1045	1231 / 129	1375 / 1334	1522 / 1462	1091 / 952	700 / 593	882 / 746	1020 / 788	1140 / 919	660 / 415	1057	1222	1364	1522	350	1057	1222	1364	1522	1060
	122 / 160	168 / 184	220 / 201	289 / 213	340 / 225	168 / 184	220 / 201	289 / 213	340 / 225	1091 / 952	700 / 593	882 / 746	1020 / 788	1140 / 919	660 / 415	1057	1222	1364	1522	CFM/ton	1057	1222	1364	1522	1060
	700 / 593	882 / 746	1033 / 874	1140 / 919	1210 / 1024	1068 / 1045	1231 / 129	1375 / 1334	1522 / 1462	1091 / 952	700 / 593	882 / 746	1020 / 788	1140 / 919	660 / 415	1057	1222	1364	1522	CFM/ton	1057	1222	1364	1522	1060
	138 / 105	170 / 138	204 / 171	246 / 220	321 / 233	1068 / 1045	1231 / 129	1375 / 1334	1522 / 1462	1091 / 952	138 / 105	170 / 138	204 / 171	246 / 220	321 / 233	1057	1222	1364	1522	CFM/ton	1057	1222	1364	1522	1060
	215 / 148	270 / 168	320 / 200	375 / 244	410 / 287	1068 / 1045	1231 / 129	1375 / 1334	1522 / 1462	1091 / 952	138 / 105	170 / 138	204 / 171	246 / 220	321 / 233	1057	1222	1364	1522	CFM/ton	1057	1222	1364	1522	1060
3.5 tons	1235 / 1312	1416 / 1471	1601 / 1618	1782 / 1847	1963 / 2028	1249 / 1214	1424 / 1383	1591 / 1536	1782 / 1847	1963 / 2028	1242 / 1128	1424 / 1383	1591 / 1536	1782 / 1847	1963 / 2028	1235	1416	1601	1782	350	1235	1416	1601	1782	1220
	178 / 227	229 / 254	288 / 274	367 / 288	420 / 299	1249 / 1214	1424 / 1383	1591 / 1536	1782 / 1847	1963 / 2028	1242 / 1128	1424 / 1383	1591 / 1536	1782 / 1847	1963 / 2028	1235	1416	1601	1782	CFM/ton	1235	1416	1601	1782	1220
	700 / 593	882 / 746	1033 / 874	1140 / 919	1210 / 1024	1249 / 1214	1424 / 1383	1591 / 1536	1782 / 1847	1963 / 2028	700 / 593	882 / 746	1033 / 874	1140 / 919	1210 / 1024	1235	1416	1601	1782	CFM/ton	1235	1416	1601	1782	1220
	138 / 105	170 / 138	204 / 171	246 / 220	321 / 233	1249 / 1214	1424 / 1383	1591 / 1536	1782 / 1847	1963 / 2028	138 / 105	170 / 138	204 / 171	246 / 220	321 / 233	1235	1416	1601	1782	CFM/ton	1235	1416	1601	1782	1220
	215 / 148	270 / 168	320 / 200	375 / 244	410 / 287	1249 / 1214	1424 / 1383	1591 / 1536	1782 / 1847	1963 / 2028	138 / 105	170 / 138	204 / 171	246 / 220	321 / 233	1235	1416	1601	1782	CFM/ton	1235	1416	1601	1782	1220
4 tons †	1168 / 1276	1355 / 1444	1555 / 1644	1755 / 1844	1955 / 2034	1424 / 1404	1614 / 1535	1814 / 1736	2014 / 1936	2214 / 2136	1399 / 1325	1589 / 1510	1789 / 1710	1989 / 1910	2189 / 2110	1168	1355	1555	1755	290	1168	1355	1555	1755	1160
	155 / 209	204 / 235	260 / 254	337 / 268	390 / 279	1424 / 1404	1614 / 1535	1814 / 1736	2014 / 1936	2214 / 2136	1399 / 1325	1589 / 1510	1789 / 1710	1989 / 1910	2189 / 2110	1168	1355	1555	1755	CFM/ton	1168	1355	1555	1755	1160
	700 / 593	882 / 746	1033 / 874	1140 / 919	1210 / 1024	1424 / 1404	1614 / 1535	1814 / 1736	2014 / 1936	2214 / 2136	700 / 593	882 / 746	1033 / 874	1140 / 919	1210 / 1024	1168	1355	1555	1755	CFM/ton	1168	1355	1555	1755	1160
	138 / 105	170 / 138	204 / 171	246 / 220	321 / 233	1424 / 1404	1614 / 1535	1814 / 1736	2014 / 1936	2214 / 2136	138 / 105	170 / 138	204 / 171	246 / 220	321 / 233	1168	1355	1555	1755	CFM/ton	1168	1355	1555	1755	1160
	215 / 148	270 / 168	320 / 200	375 / 244	410 / 287	1424 / 1404	1614 / 1535	1814 / 1736	2014 / 1936	2214 / 2136	138 / 105	170 / 138	204 / 171	246 / 220	321 / 233	1168	1355	1555	1755	CFM/ton	1168	1355	1555	1755	1160
Factory Setting	1714 / 1605	1686 / 1525	1550 / 1452	1500 / 1385	1390 / 1321	1424 / 1404	1614 / 1535	1814 / 1736	2014 / 1936	2214 / 2136	1500 / 1452	1550 / 1452	1500 / 1385	1390 / 1321	1390 / 1321	1714	1686	1550	1500	450	1714	1686	1550	1500	1390
	431 / 435	505 / 468	584 / 492	617 / 510	520 / 570	1424 / 1404	1614 / 1535	1814 / 1736	2014 / 1936	2214 / 2136	1500 / 1452	1550 / 1452	1500 / 1385	1390 / 1321	1390 / 1321	1714	1686	1550	1500	CFM/ton	1714	1686	1550	1500	1390
	700 / 593	882 / 746	1033 / 874	1140 / 919	1210 / 1024	1424 / 1404	1614 / 1535	1814 / 1736	2014 / 1936	2214 / 2136	700 / 593	882 / 746	1033 / 874	1140 / 919	1210 / 1024	1714	1686	1550	1500	CFM/ton	1714	1686	1550	1500	1390
	138 / 105	170 / 138	204 / 171	246 / 220	321 / 233	1424 / 1404	1614 / 1535	1814 / 1736	2014 / 1936	2214 / 2136	138 / 105	170 / 138	204 / 171	246 / 220	321 / 233	1714	1686	1550	1500	CFM/ton	1714	1686	1550	1500	1390
	215 / 148	270 / 168	320 / 200	375 / 244	410 / 287	1424 / 1404	1614 / 1535	1814 / 1736	2014 / 1936	2214 / 2136	138 / 105	170 / 138	204 / 171	246 / 220	321 / 233	1714	1686	1550	1500	CFM/ton	1714	1686	1550	1500	1390

- † Factory Setting
- Status LED will blink once per 100 CFM requested. In torque mode, actual airflow may be lower.
- In communicating mode, default CFM/Ton is 400.
- Torque mode will reduce airflow when static is above approximately 0.3" water column.
- All heating modes default to Constant CFM.
- Cooling airflow values are with wet coil, no filter

		TEM8A0C48V41DC & TEM8B0C60V51DA AIRFLOW PERFORMANCE										CONSTANT CFM MODE / CONSTANT TORQUE MODE									
OUTDOOR MULTIPLIER (TONS)	COOLING AIRFLOW SETTING	AIRFLOW POWER	EXTERNAL STATIC PRESSURE (Constant CFM / Constant Torque)										HEATING AIRFLOW SETTING	AIRFLOW POWER	EXTERNAL STATIC PRESSURE						
			0.1	0.3	0.5	0.7	0.9	0.9	0.1	0.3	0.5	0.7			0.9						
3 tons	290 CFM/ton	CFM Watts	864/1015	856/883	851/772	850/676	820/590	290	864	856	851	843	822	290 CFM/ton	CFM Watts	76	119	168	219	276	
	350 CFM/ton	CFM Watts	1037/1179	1037/1059	1040/957	1030/866	1030/784	350	1037	1037	1040	1039	1032	350 CFM/ton	CFM Watts	110	158	213	271	334	
	400 CFM/ton	CFM Watts	1184/1317	1187/1207	1193/1110	1180/1024	1190/945	400	1184	1187	1193	1196	1197	400 CFM/ton	CFM Watts	149	200	260	324	393	
	450 CFM/ton	CFM Watts	1334/1457	1336/1354	1343/1263	1340/1181	1340/1105	450	1334	1336	1343	1348	1353	450 CFM/ton	CFM Watts	198	254	318	388	461	
	290 CFM/ton	CFM Watts	1015/1147	1000/1025	1000/921	1000/829	1000/746	290	1003	1002	1004	1002	992	290 CFM/ton	CFM Watts	103	149	203	260	322	
3.5 tons	350 CFM/ton	CFM Watts	1210/1341	1210/1231	1210/1136	1210/1050	1210/971	350	1209	1212	1218	1222	1224	350 CFM/ton	CFM Watts	157	208	269	334	403	
	400 CFM/ton	CFM Watts	1380/1503	1380/1403	1390/1314	1390/1233	1390/1159	400	1384	1386	1393	1397	1402	400 CFM/ton	CFM Watts	217	275	340	412	487	
	450 CFM/ton	CFM Watts	1560/1667	1560/1575	1570/1492	1570/1416	1579/1345	450	1563	1563	1566	1566	1564	450 CFM/ton	CFM Watts	293	362	429	507	588	
	290 CFM/ton	CFM Watts	1140/1304	1140/1192	1140/1095	1140/1008	1150/929	290	1144	1147	1152	1155	1154	290 CFM/ton	CFM Watts	138	188	247	309	376	
	350 CFM/ton	CFM Watts	1380/1525	1380/1426	1390/1338	1390/1257	1390/1183	350	1384	1386	1393	1397	1402	350 CFM/ton	CFM Watts	217	275	340	412	487	
4 tons	400 CFM/ton	CFM Watts	1590/1711	1590/1621	1590/1539	1590/1464	1600/1394	400	1589	1588	1591	1589	1585	400 CFM/ton	CFM Watts	305	376	444	522	604	
	450 CFM/ton	CFM Watts	1790/1898	1790/1816	1800/1741	1800/1670	1810/1604	450	1800	1794	1791	1773	1745	450 CFM/ton	CFM Watts	419	509	575	660	749	
	290 CFM/ton	CFM Watts	1430/1571	1440/1475	1440/1388	1440/1309	1440/1236	290	1435	1436	1442	1446	1450	290 CFM/ton	CFM Watts	237	297	364	437	514	
	350 CFM/ton	CFM Watts	1740/1851	1740/1767	1750/1690	1750/1619	1760/1552	350 †	1747	1742	1740	1728	1707	350 CFM/ton	CFM Watts	388	472	539	623	710	
	400 CFM/ton	CFM Watts	2000/2087	2000/2012	2010/1942	1980/1873	1870/317	400	2015	2007	1995	1951	1877	400 CFM/ton	CFM Watts	559	679	739	810	810	
5 tons	450 CFM/ton	CFM Watts	2260/2141	2210/2068	2100/1999	1980/903	1870/315	450	2125	2117	2100	2038	1932	450 CFM/ton	CFM Watts	641	779	810	810	810	
	290 CFM/ton	CFM Watts	745/686	810/729	810/766	810/359	810/405	290	745	742	740	728	710	290 CFM/ton	CFM Watts	641	779	810	810	810	

- † Factory Setting
- Status LED will blink once per 100 CFM requested. In torque mode, actual airflow may be lower.
- In communicating mode, default CFM/Ton is 400.
- Torque mode will reduce airflow when static is above approximately 0.3" water column.
- All heating modes default to Constant CFM.
- Cooling airflow values are with wet coil, no filter

## Performance and Electrical Data

**Note:** Heater size needs to be set in Configuration Menu.

**Table 7. Electrical Data**

<b>TEM8A0B24V21DC HEATER DATA</b>											
Heater Model No.	No. of Circuits/ Phases	240 Volt					208 Volt				
		Capacity		Heater Amps per Circuit	Minimum Circuit Ampacity	Maximum Overload Protection	Capacity		Heater Amps per Circuit	Minimum Circuit Ampacity	Maximum Overload Protection
		kW	BTUH				kW	BTUH			
No Heater				2.8 *	4	15			2.8 *	4	15
BAYHTR1504BRK BAYHTR1504LUG	1/1	3.84	13100	16.0	24	25	2.88	9800	13.8	21	25
BAYHTR1505BRK BAYHTR1505LUG	1/1	4.80	16400	20.0	29	30	3.60	12300	17.3	25	25
BAYHTR1508BRK BAYHTR1508LUG	1/1	7.68	26200	32.0	44	45	5.76	19700	27.7	38	40
BAYHTR1510BRK BAYHTR1510LUG	1/1	9.60	32800	40.0	54	60	7.20	24600	34.6	47	50
BAYHTR1517BRK Circuit 1 <sup>(a)</sup>	2/1	9.60	32800	40.0	54	60	7.20	24600	34.6	47	50
BAYHTR1517BRK Circuit 2		4.80	16400	20.0	25	25	3.60	12300	17.3	22	25
BAYHTR3510LUG	1/3	9.60	32800	23.1	32	35	7.20	24600	20.0	28	30
BAYHTR3517LUG	1/3	14.40	49100	34.6	46	50	10.80	36900	30.0	41	45

\* = Motor Amps

<sup>(a)</sup> MCA and MOP for circuit 1 contains the motor amps

**Table 8. Electrical Data**

<b>TEM8A0B30V31DC HEATER DATA</b>											
Heater Model No.	No. of Circuits/ Phases	240 Volt					208 Volt				
		Capacity		Heater Amps per Circuit	Minimum Circuit Ampacity	Maximum Overload Protection	Capacity		Heater Amps per Circuit	Minimum Circuit Ampacity	Maximum Overload Protection
		kW	BTUH				kW	BTUH			
No Heater				3.9 *	5	15			3.9 *	5	15
BAYHTR1504BRK BAYHTR1504LUG	1/1	3.84	13100	16.0	25	25	2.88	9800	13.8	22	25
BAYHTR1505BRK BAYHTR1505LUG	1/1	4.80	16400	20.0	30	30	3.60	12300	17.3	27	30
BAYHTR1508BRK BAYHTR1508LUG	1/1	7.68	26200	32.0	45	45	5.76	19700	27.7	39	40
BAYHTR1510BRK BAYHTR1510LUG	1/1	9.60	32800	40.0	55	60	7.20	24600	34.6	48	50
BAYHTR1517BRK Circuit 1 <sup>(a)</sup>	2/1	9.60	32800	40.0	55	60	7.20	24600	34.6	48	50
BAYHTR1517BRK Circuit 2		4.80	16400	20.0	25	25	3.60	12300	17.3	22	25
BAYHTR3510LUG	1/3	9.60	32800	23.1	33	35	7.20	24600	20.0	29	30
BAYHTR3517LUG	1/3	14.40	49100	34.6	48	50	10.80	36900	30.0	42	45

\* = Motor Amps

<sup>(a)</sup> MCA and MOP for circuit 1 contains the motor amps

**Table 9. Electrical Data**

<b>TEM8A0C36V31DC, TEM8A0C42V41DC HEATER DATA</b>											
Heater Model No.	No. of Circuits/ Phases	240 Volt					208 Volt				
		Capacity		Heater Amps per Circuit	Minimum Circuit Ampacity	Maximum Overload Protection	Capacity		Heater Amps per Circuit	Minimum Circuit Ampacity	Maximum Overload Protection
		kW	BTUH				kW	BTUH			
No Heater				3.9 *	5	15			3.9 *	5	15
BAYHTR1504BRK BAYHTR1504LUG	1/1	3.84	13100	16.0	25	25	2.88	9800	13.8	22	25
BAYHTR1505BRK BAYHTR1505LUG	1/1	4.80	16400	20.0	30	30	3.60	12300	17.3	27	30



**Table 9. Electrical Data (continued)**

<b>TEM8A0C36V31DC, TEM8A0C42V41DC HEATER DATA</b>											
BAYHTR1508BRK BAYHTR1508LUG	1/1	7.68	26200	32.0	45	45	5.76	19700	27.7	39	40
BAYHTR1510BRK BAYHTR1510LUG	1/1	9.60	32800	40.0	55	60	7.20	24600	34.6	48	50
BAYHTR1517BRK Circuit 1 <sup>(a)</sup>	2/1	9.60	32800	40.0	55	60	7.20	24600	34.6	48	50
BAYHTR1517BRK Circuit 2		4.80	16400	20.0	25	25	3.60	12300	17.3	22	25
BAYHTR1523BRK Circuit 1 <sup>(a)</sup>	2/1	9.60	32800	40.0	55	60	7.20	24600	34.6	48	50
BAYHTR1523BRK Circuit 2		9.60	32800	40.0	50	50	7.20	24600	34.6	43	45
BAYHTR3510LUG	1/3	9.60	32800	23.1	33	35	7.20	24600	20.0	29	30
BAYHTR3517LUG	1/3	14.40	49100	34.6	48	50	10.80	36900	30.0	42	45

\* = Motor Amps

<sup>(a)</sup> MCA and MOP for circuit 1 contains the motor amps

**Table 10. Electrical Data**

<b>TEM8A0C48V41DC, TEM8B0C60V51DA HEATER DATA</b>											
Heater Model No.	No. of Circuits/ Phases	240 Volt					208 Volt				
		Capacity		Heater Amps per Circuit	Minimum Circuit Ampacity	Maximum Overload Protection	Capacity		Heater Amps per Circuit	Minimum Circuit Ampacity	Maximum Overload Protection
		kW	BTUH				kW	BTUH			
No Heater				5.7 *	7	15			5.7 *	7	15
BAYHTR1504BRK BAYHTR1504LUG	1/1	3.84	13100	16.0	27	30	2.88	9800	13.8	24	25
BAYHTR1505BRK BAYHTR1505LUG	1/1	4.80	16400	20.0	32	35	3.60	12300	17.3	29	30
BAYHTR1508BRK BAYHTR1508LUG	1/1	7.68	26200	32.0	47	50	5.76	19700	27.7	42	45
BAYHTR1510BRK BAYHTR1510LUG	1/1	9.60	32800	40.0	57	60	7.20	24600	34.6	50	50
BAYHTR1517BRK Circuit 1 <sup>(a)</sup>	2/1	9.60	32800	40.0	57	60	7.20	24600	34.6	50	50
BAYHTR1517BRK Circuit 2		4.80	16400	20.0	25	25	3.60	12300	17.3	22	25
BAYHTR1523BRK Circuit 1 <sup>(a)</sup>	2/1	9.60	32800	40.0	57	60	7.20	24600	34.6	50	50
BAYHTR1523BRK Circuit 2		9.60	32800	40.0	50	50	7.20	24600	34.6	43	45
BAYHTR1525BRK Circuit 1 <sup>(a)</sup>	4/1	6.00	20500	25.0	38	40	4.50	15400	21.6	34	35
BAYHTR1525BRK Circuit 2		6.00	20500	25.0	31	35	4.50	15400	21.6	27	30
BAYHTR1525BRK Circuit 3		6.00	20500	25.0	31	35	4.50	15400	21.6	27	30
BAYHTR1525BRK Circuit 4		6.00	20500	25.0	31	35	4.50	15400	21.6	27	30
BAYHTR3510LUG	1/3	9.60	32800	23.1	35	35	7.20	24600	20.0	31	35
BAYHTR3517LUG	1/3	14.40	49100	34.6	50	50	10.80	36900	30.0	44	45

\* = Motor Amps

<sup>(a)</sup> MCA and MOP for circuit 1 contains the motor amps

# Minimum Airflow CFM

TEM8A0B24V21DC, TEM8A0B30V31DC		
Heater	Minimum Heater Airflow CFM	
	With Heat Pump	Without Heat Pump
BAYHTR1504BRK, BAYHTR1504LUG, BAYHTR1505BRK, BAYHTR1505LUG	650	600
BAYHTR1508BRK, BAYHTR1508LUG	850	700
BAYHTR1510BRK, BAYHTR1510LUG	850	700
BAYHTR1517BRK	1000	850
BAYHTR3510LUG	850	700
BAYHTR3517LUG	1000	850

TEM8A0C36V31DC, TEM8A0C42V41DC		
Heater	Minimum Heater Airflow CFM	
	With Heat Pump	Without Heat Pump
BAYHTR1504BRK, BAYHTR1504LUG, BAYHTR1505BRK, BAYHTR1505LUG	675	675
BAYHTR1508BRK, BAYHTR1508LUG	950	900
BAYHTR1510BRK, BAYHTR1510LUG	950	900
BAYHTR1517BRK	950	900
BAYHTR3510LUG	950	900
BAYHTR3517LUG	1050	950
BAYHTR1523BRK	1500	1300

TEM8A0C48V41DC, TEM8B0C60V51DA		
Heater	Minimum Heater Airflow CFM	
	With Heat Pump	Without Heat Pump
BAYHTR1504BRK, BAYHTR1504LUG, BAYHTR1505BRK, BAYHTR1505LUG	900	800
BAYHTR1508BRK, BAYHTR1508LUG	1200	1000
BAYHTR1510BRK, BAYHTR1510LUG	1350	1000
BAYHTR1517BRK	1400	1100
BAYHTR3510LUG	1200	1000
BAYHTR3517LUG	1400	1100
BAYHTR1523BRK	1430	1300
BAYHTR1525BRK	1850	1600

# Outline Drawing

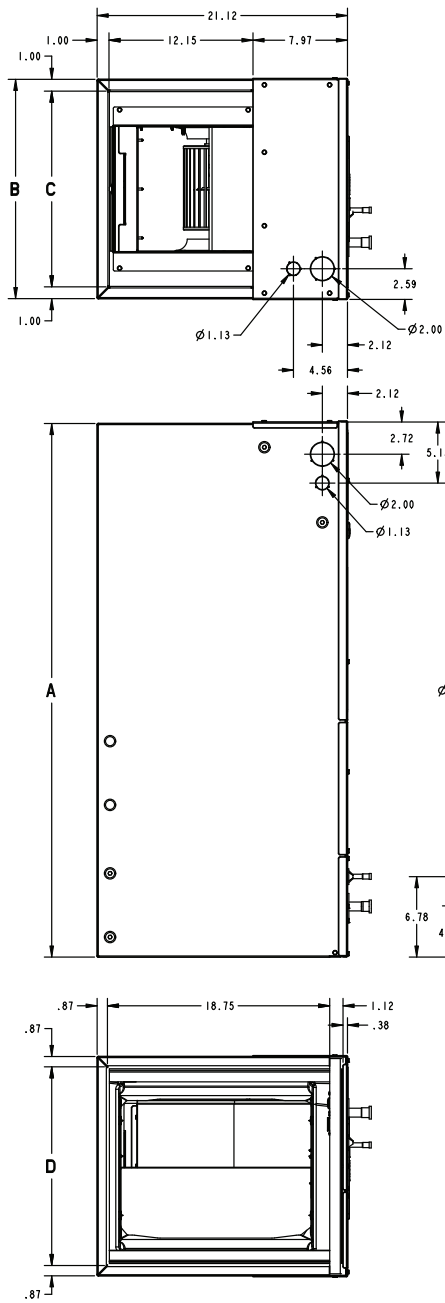

MINIMUM UNIT CLEARANCE TABLE	
	SERVICE CLEARANCE (RECOMMENDED)
SIDES	2"
FRONT	21"
BACK	0"
INLET DUCT	1"
OUTLET DUCT	N/A

NOTE: THIS UNIT IS APPROVED FOR INSTALLATION CLEARANCES TO COMBUSTIBLE MATERIAL AS STATED ON THE UNIT RATING NAMEPLATE

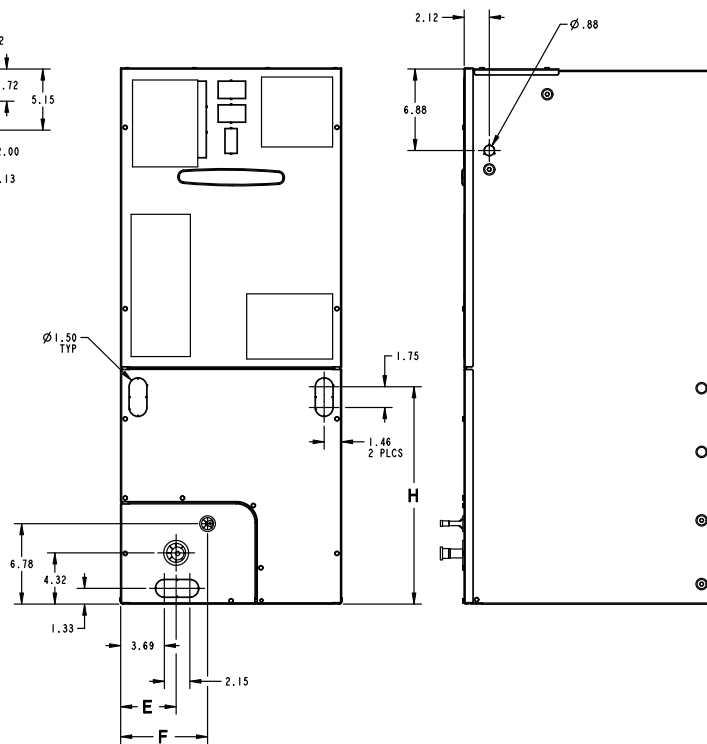

## PRODUCT DIMENSIONS

Air Handler Model	A	B	C	D	E	F	H	Flow Control	Gas Line Braze
TEM8A0B24, 30	46.77	18.50	16.50	16.75	4.68	7.33	20.09	TXV	3/4
TEM8A0C36, 42	51.27	23.50	21.50	21.75	7.01	9.66	24.59	TXV	7/8
TEM8A0C48/ TEM8B0C60	57.40	23.50	21.50	21.75	4.68	9.66	27.19	TXV	7/8

All dimensions are in inches

# Heater Pressure Drop Table

Airflow CFM	Number of Racks				Heater Racks	
	1	2	3	4	Heater Model	No. of Racks
	Air Pressure Drop — Inches W.G.					
1800	0.02	0.04	0.06	0.14	BAYHTR1504	1
1700	0.02	0.04	0.06	0.14	BAYHTR1505	1
1600	0.02	0.04	0.06	0.13	BAYHTR1508	2
1500	0.02	0.04	0.06	0.12	BAYHTR1510	2
1400	0.02	0.04	0.06	0.12	BAYHTR3510	3
1300	0.02	0.04	0.05	0.11	BAYHTR1517	3
1200	0.01	0.04	0.05	0.10	BAYHTR1523	4
1100	0.01	0.03	0.05	0.09	BAYHTR3517	3
1000	0.01	0.03	0.04	0.09	BAYHTR1525	4
900	0.01	0.03	0.04	0.08		
800	0.01	0.03				
700	0.01	0.02				
600	0.01	0.02				

## Subcooling Adjustment

System Matched with:	Indoor Unit Model No.	Outdoor Model No.	Subcooling
15 SEER HP — 3 ton	TEM8A0C36V31 TEM8A0C42V41	4TWR5036G1000A 4A6H5036G1000A	14 Degrees
All other matches must be charged per the nameplate charging instructions			

## Subcooling Adjustment for TEM8A0C48V41 & TEM8B0C60V51

Sub-Cooling Charge Specification For AHRI Rated Performance		
OD Equipment	Up Flow / Horizontal	Down Flow
AC UNIT	OD Name Plate	OD Name Plate
HP UNIT ≤ 3.5 Tons	OD Name Plate	OD Name Plate + 4 Degrees
HP UNIT = 4 and 5 Tons	OD Name Plate	OD Name Plate

# Coil Conversion Instructions

## Downflow

Follow the conversion steps when installing the air handler in downflow configuration.

1. Remove the front panels panel from the air handler. The coil and line set panel do not need to be separated.
2. Remove the fasteners on both sides of the coil.
3. Remove the two screws holding the center horizontal bracket and rotate out of place. Retain parts.

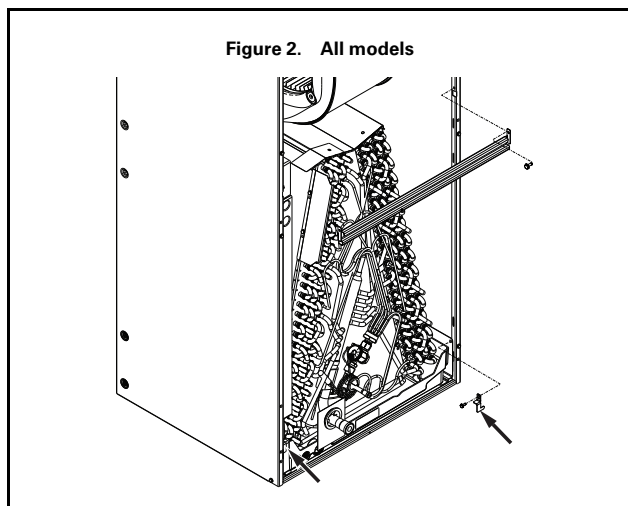

4. Slide the coil assembly out. Remove and discard the horizontal drain pan.

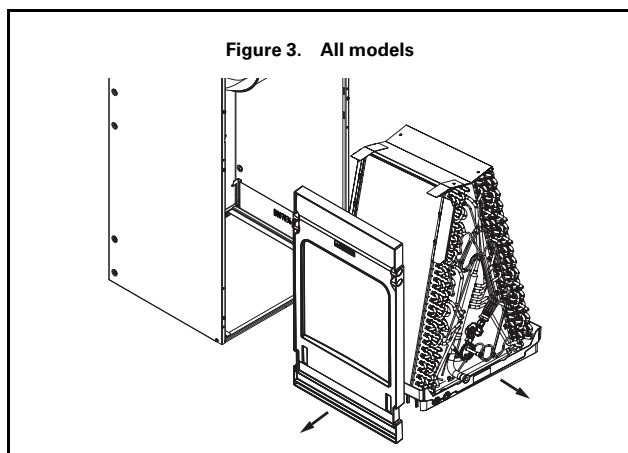

5. On both sides of the cabinet, remove the screws that hold the coil support brackets and retain for later use. Seal the holes to prevent air leakage.
6. Rotate and lift the two coil support brackets to remove from front slots in cabinet.

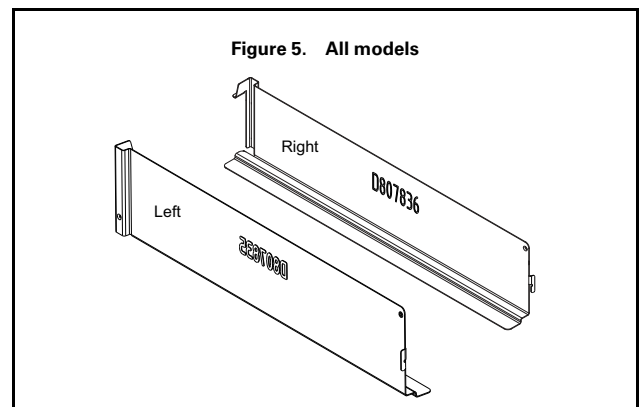
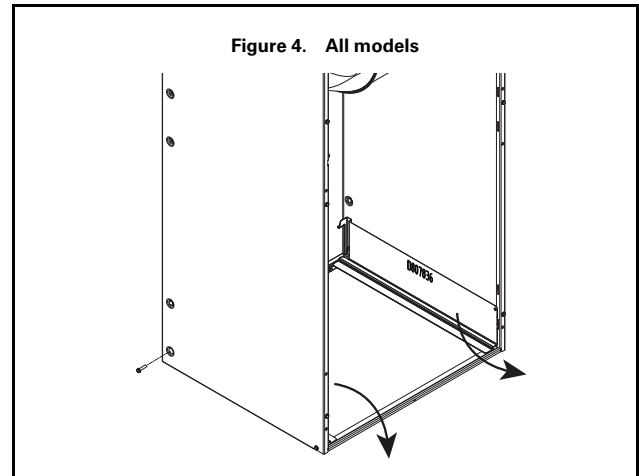

7. Rotate the unit into the downflow orientation.
8. Pre-drill two clearance holes in the cabinet at dimples located below the location the screws were removed for the coil support brackets. There is one hole per side. See location of holes.
9. Replace the center horizontal bracket removed in Step 3. Use the screws retained from Step 3 to attach.
10. Place coil support brackets into the lower set of slots and rotate into place. Push downward to lock into place.
11. Secure each bracket with a screw that were previously removed.

## Coil Conversion Instructions

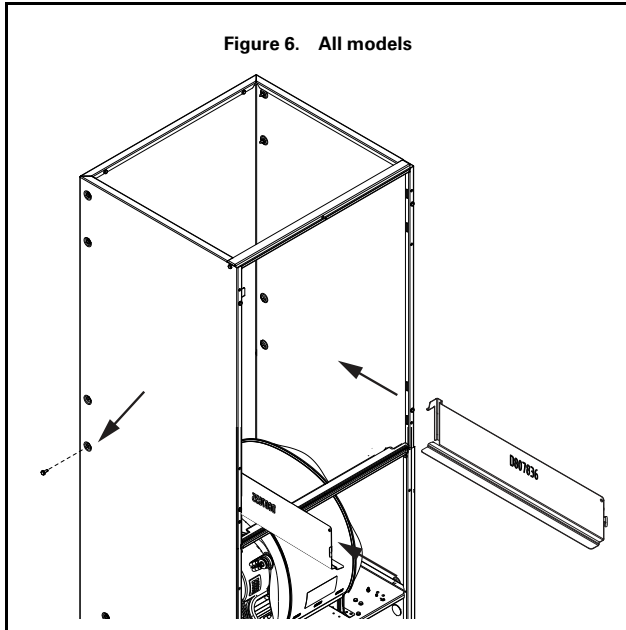

12. Slide the coil assembly back into the air handler cabinet as shown.

13. Remove the appropriate knock out for the condensate piping.

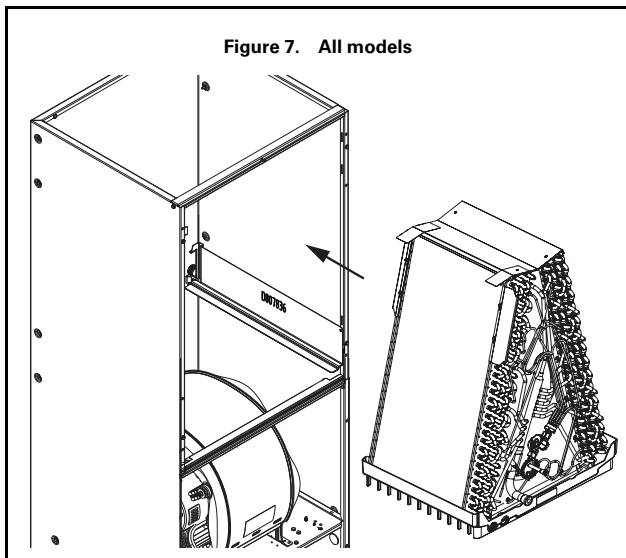

14. Replace all panels.

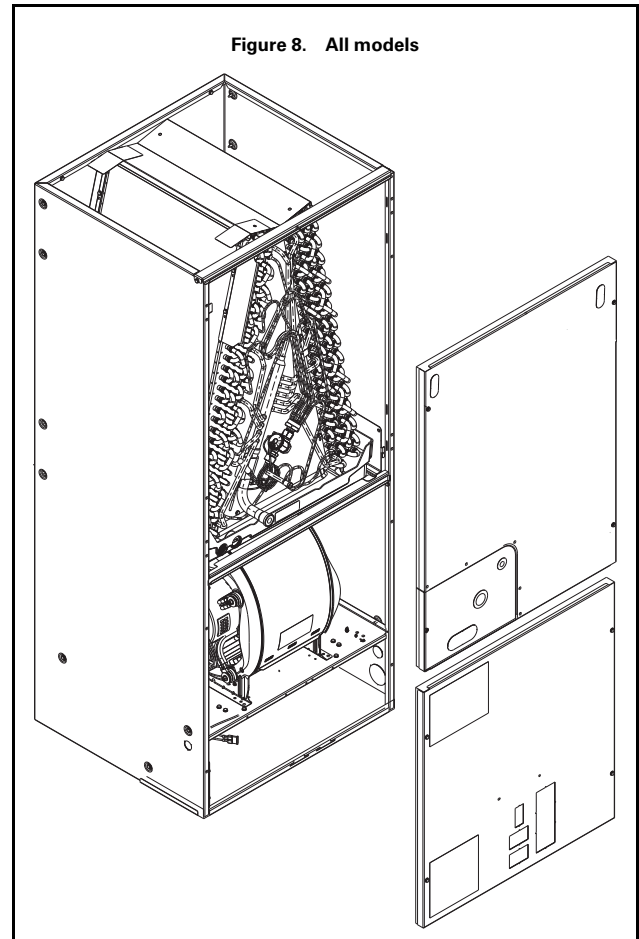

### Horizontal Right

Follow the conversion steps when installing the air handler in horizontal right configuration.

1. Remove the front panels from the air handler. The coil and line set panel do not need to be separated.
2. Remove the fasteners on both sides of the coil. Retain the coil retaining brackets and screws.
3. Remove the two screws holding the center horizontal bracket and rotate out of place. Retain parts.

Figure 9. All models

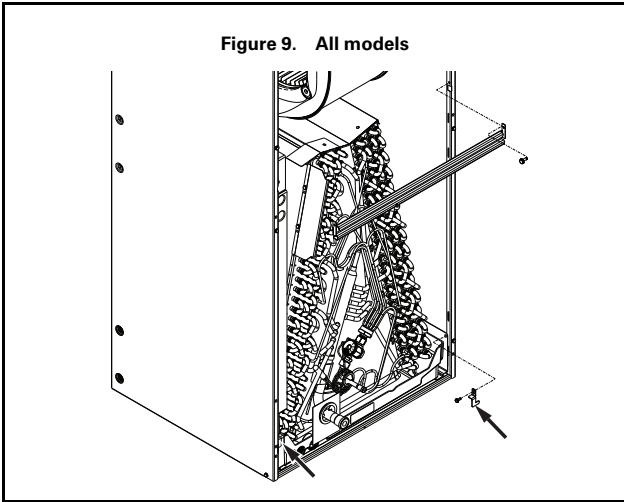

4. Make note of the horizontal drain pan orientation (up/down).
5. Slide the coil assembly out.

Figure 10. All models

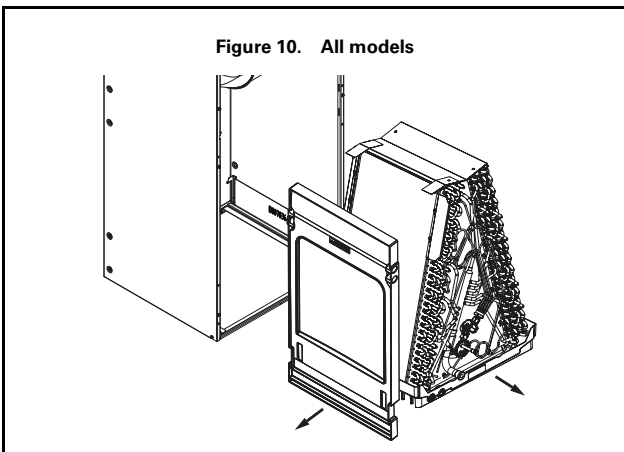

**Important:** For Horizontal Right applications, ON SOME MODELS the top panel assembly of the coil must be rotated for proper condensate management.

6. On the right side of the top baffle, position a flathead tip underneath the top baffle flange and pivot the screwdriver downward to release the front tab as shown below.
7. Repeat for right rear tab to release top baffle assembly from coil.

Figure 11. All models

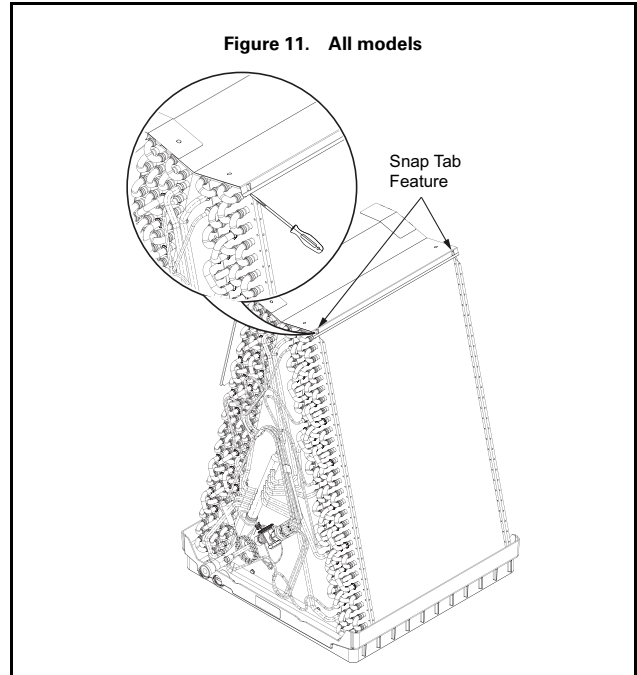

8. Rotate 180 degrees and snap all four corner tabs to lock in place.
9. Remove left side water diverter brackets and screws and reinstall on the right side.

**Important:** The coil slabs are different and the mount hole locations will vary. See the illustrations on the following pages that correspond to the unit tonnage to see the correct mounting position of the water diverter bracket.

**Important:** The water diverter brackets are not symmetrical and will vary by tonnage.

Figure 12. All models

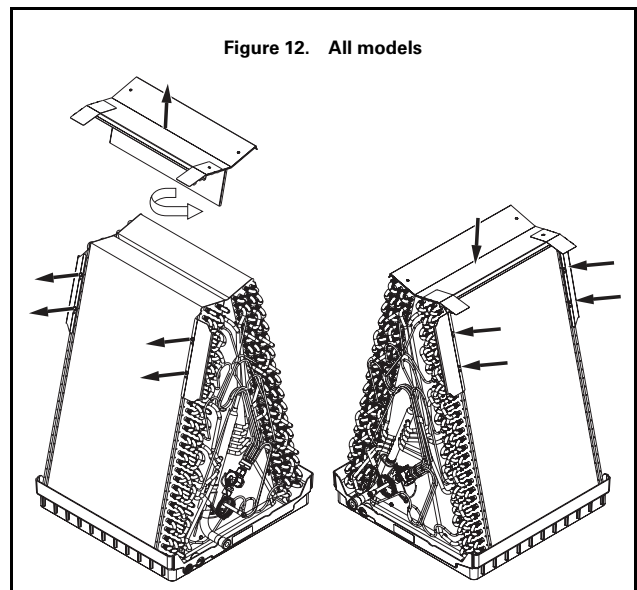

# Coil Conversion Instructions

Figure 13. TEM8A0B24V21DC, TEM8A0B30V31DC

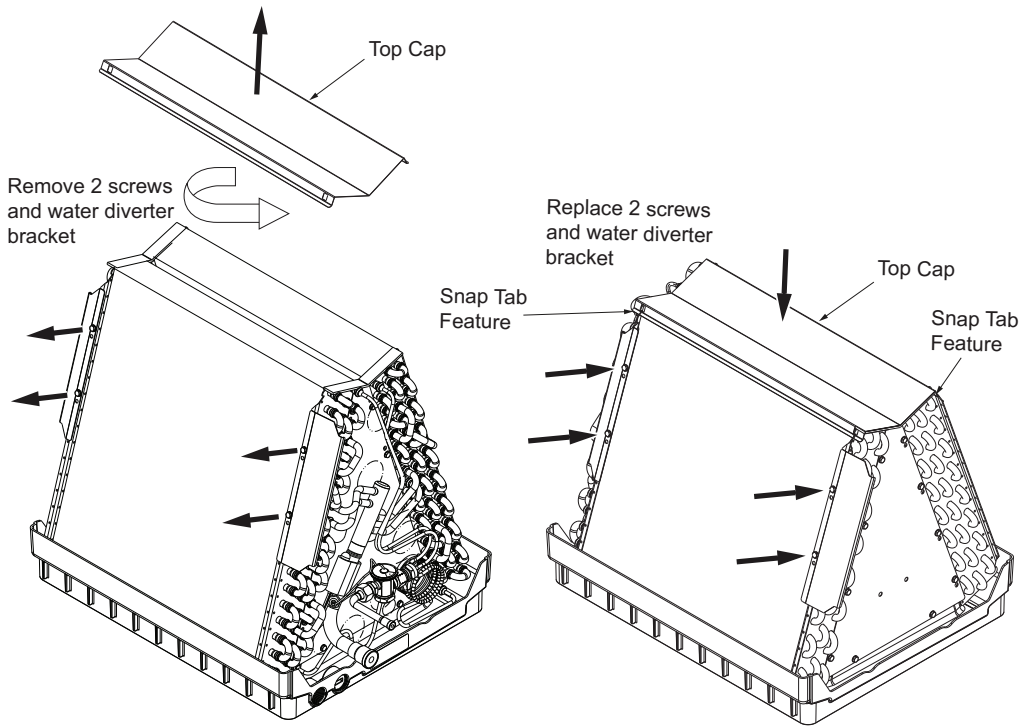
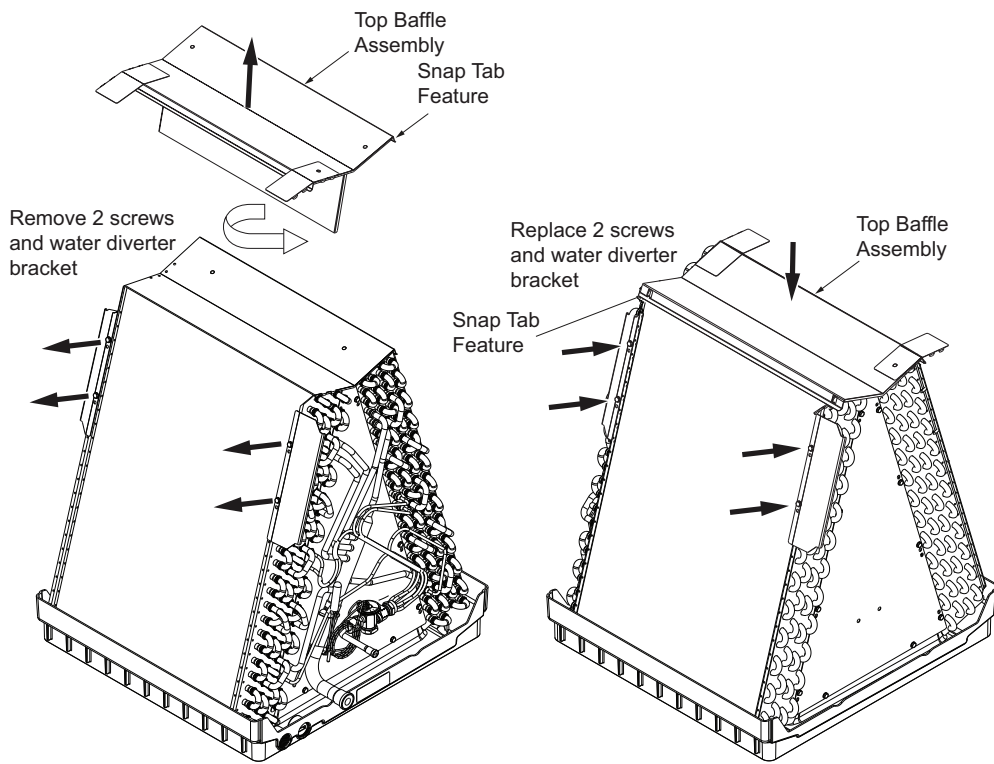
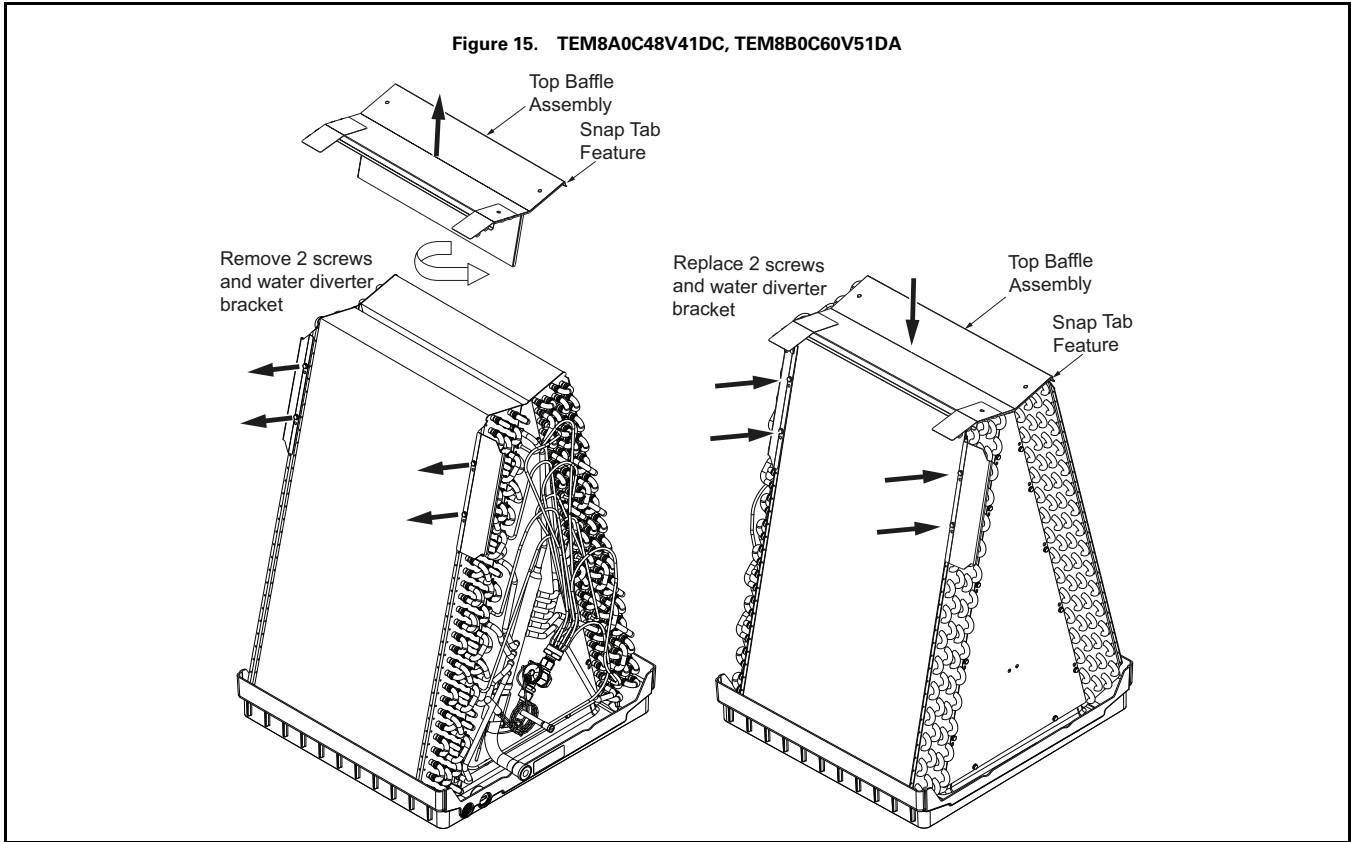

Figure 14. TEM8A0C36V31DC, TEM8A0C42V41DC







10. Relocate the horizontal drain pan from the left side of the coil to the right side.
11. Remove the drain pan support bracket. Do not discard. Remove the two drain plugs from the front of the drain pan and insert them in the drains at the rear of the drain pan.

**Important:** When reinstalling coil in Step 13, it is important that the coil corner locks in place under the tab in the side bracket to support the coil weight horizontally.

12. Reinstall the drain pan support bracket. The bracket should be located between the two drain plugs as shown.

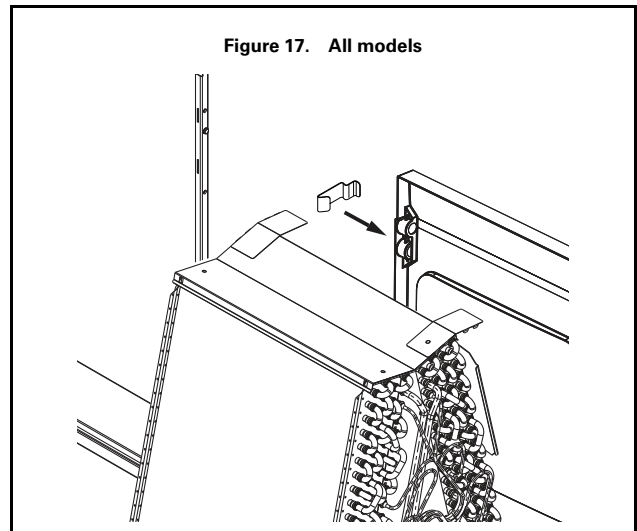
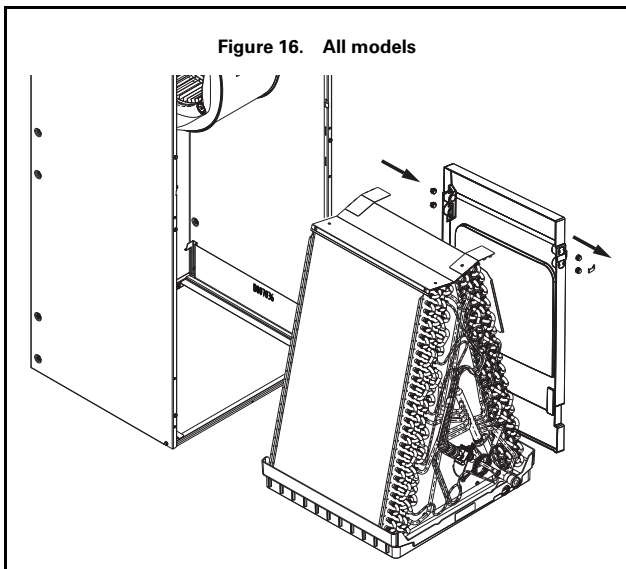

13. Slide the coil assembly back into the air handler cabinet.

**Important:** Make sure that the coil corner locks in place under the tab in the side left bracket to support the coil weight in the horizontal right position.

## Coil Conversion Instructions

---

14. Replace the center horizontal bracket using screws removed earlier in Step 3.
15. Replace the two coil retaining brackets removed in a previous step.
16. Replace all panels.

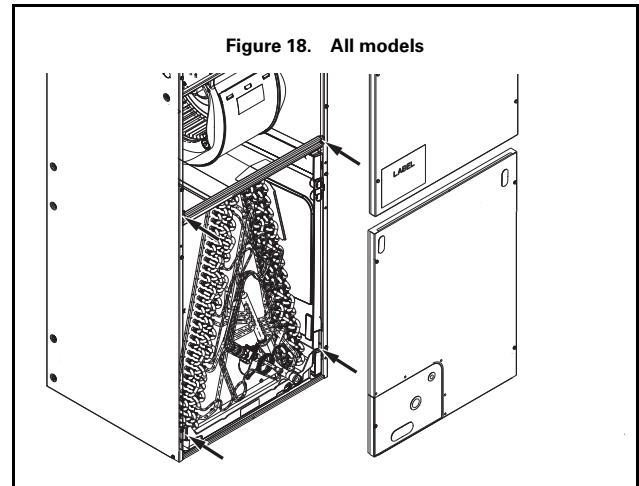

# Checkout Procedures

The final phase of the installation is the system Checkout Procedures. The following list represents the most common items covered in a Checkout Procedure. Confirm all requirements in this document have been met.

<ul style="list-style-type: none"><li><input type="checkbox"/> All wiring connections are tight and properly secured.</li><li><input type="checkbox"/> Voltage and running current are within limits.</li><li><input type="checkbox"/> All refrigerant lines (internal and external to equipment) are isolated, secure, and not in direct contact with each other or structure.</li><li><input type="checkbox"/> All braze connections have been checked for leaks. A vacuum of 350 microns provides confirmation that the refrigeration system is leak free and dry.</li><li><input type="checkbox"/> Final unit inspection to confirm factory tubing has not shifted during shipment. Adjust tubing if necessary so tubes do not rub against each other or any component when unit runs.</li><li><input type="checkbox"/> Ductwork is sealed and insulated.</li><li><input type="checkbox"/> All drain lines are clear with joints properly sealed. Pour water into drain pan to confirm proper drainage. Provide enough water to ensure drain trap is primed.</li><li><input type="checkbox"/> For TEM8 models, set the heater size in the Configuration Menu.</li></ul>	<ul style="list-style-type: none"><li><input type="checkbox"/> Supply registers and return grilles are open, unobstructed, and air filter is installed.</li><li><input type="checkbox"/> Indoor blower and outdoor fan are operating smoothly and without obstruction.</li><li><input type="checkbox"/> Indoor blower motor set on correct speed setting to deliver required CFM.</li><li><input type="checkbox"/> Cover panels are in place and properly tightened.</li><li><input type="checkbox"/> For gas heating systems, manifold pressure has been checked and all gas line connections are tight and leak free.</li><li><input type="checkbox"/> For gas heating systems, flue gas is properly vented.</li><li><input type="checkbox"/> System functions safely and properly in all modes.</li><li><input type="checkbox"/> Owner has been instructed on use of system and given manual.</li></ul>
---	--

## About Trane and American Standard Heating and Air Conditioning

Trane and American Standard create comfortable, energy efficient indoor environments for residential applications. For more information, please visit [www.trane.com](http://www.trane.com) or [www.americanstandardair.com](http://www.americanstandardair.com).

---



The manufacturer has a policy of continuous data improvement and it reserves the right to change design and specifications without notice. We are committed to using environmentally conscious print practices.