

Installer's Guide

18-EB38D1-1A-EN

Single Packaged Dual Fuel 14 SEER Convertible, NOx Limiting, 2 - 5 Ton, 60 - 115 MBTU R-410A

ALL phases of this installation must comply with NATIONAL, STATE AND LOCAL CODES

IMPORTANT — This Document is customer property. Please return this Installer's Guide to service information pack and give to the homeowner upon completion of work.

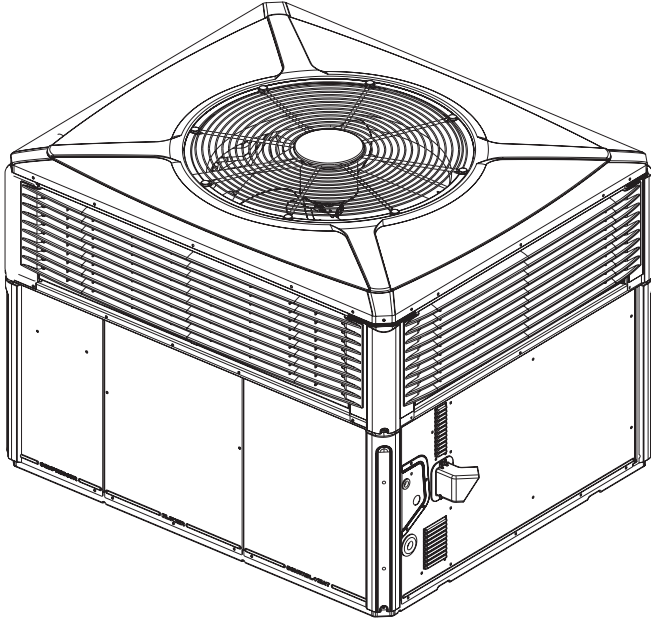

4DCL4024 through 4DCL4060

⚠ WARNING

SAFETY HAZARD!

This information is for use by individuals having adequate backgrounds of electrical and mechanical experience. Any attempt to repair a central air conditioning product may result in personal injury and/or property damage. The manufacturer or seller cannot be responsible for the interpretation of this information, nor can it assume any liability in connection with its use.

⚠ WARNING

HAZARDOUS GASSES!

Exposure to fuel substances, or by-products of incomplete fuel combustion, is believed by the state of California to cause cancer, birth defects, or other reproductive harm.

This warning complies with State of California law, Proposition 65.

This product must be gas piped by a Licensed Plumber or Gas Fitter in the Commonwealth of Massachusetts.

⚠ WARNING

WARNING!

This product can expose you to chemicals including lead, which are known to the State of California to cause cancer and birth defects or other reproductive harm. For more information go to www.P65Warnings.ca.gov

⚠ WARNING

HAZARDOUS VOLTAGE, MOVING PARTS, AND GAS!

Bodily injury can result from high voltage electrical components, fast moving fans, and combustible gas. For protection from these inherent hazards during installation and service, the electrical supply must be disconnected and the main gas valve must be turned off. If operating checks must be performed with the unit operating, it is the technician's responsibility to recognize these hazards and proceed safely.

⚠ WARNING

SAFETY HAZARD!

Do not operate the unit without the evaporator fan or coil access panels in place. Reinstall the access panels after performing maintenance procedures on the fan. Operating the unit without the access panels properly installed may result in severe personal injury or death.

⚠ WARNING: HAZARDOUS VOLTAGE - DISCONNECT POWER and DISCHARGE CAPACITORS BEFORE SERVICING

Installer's Guide

Safety Considerations

IMPORTANT: Read this entire manual before beginning installation procedures.

NOTICE

Warning and Cautions appear at appropriate locations throughout this guide. Read these carefully.

⚠ WARNING: INDICATES A POTENTIALLY HAZARDOUS SITUATION WHICH, IF NOT AVOIDED, COULD RESULT IN DEATH OR SERIOUS INJURY.

⚠ CAUTION: Indicates a potentially hazardous situation which, if not avoided, may result in minor or moderate injury. It may also be used to alert against unsafe practices and where property-damage-only accidents could occur.

⚠ WARNING

This product contains fiberglass wool insulation! Fiberglass dust and ceramic fibers are believed by the state of California to cause cancer through inhalation. Glasswool fibers may also cause respiratory, skin, or eye irritation.

PRECAUTIONARY MEASURES

- Avoid breathing fiberglass dust
- Use a NIOSH approved dust/mist respirator
- Avoid contact with the skin or eyes. Wear long-sleeved, loose fitting clothing, gloves, and eye protection.
- Wash clothes separately from other clothing, rinse washer thoroughly.
- Operations, such as sawing, blowing, tear-out, and spraying may generate fiber concentrations requiring additional respiratory protection. Use the appropriate NIOSH approved respirator in these situations.

FIRST AID MEASURES

Eye Contact: Flush eyes with water to remove dust. If symptoms persist, seek medical attention.

Skin Contact: Wash affected area gently with soap and warm water after handling.

⚠ WARNING

EXPLOSION HAZARD!

Propane gas is heavier than air and may collect in any low areas or confined spaces. In addition, odorant fade may make the gas undetectable except with a warning device. If the gas furnace is installed in a basement, an excavated area or a confined space, it is strongly recommended to contact a gas supplier to install a gas detecting warning device in case of leak. The manufacturer of your furnace does not test any detectors and makes no representations regarding any brand or type of detector.

⚠ WARNING

EXPLOSION HAZARD!

To prevent an explosion or possible injury, death, and equipment damage, do not store combustible materials, gasoline, or other flammable vapors or liquids near the unit.

⚠ WARNING

CONTAINS REFRIGERANT!
SYSTEM CONTAINS OIL AND REFRIGERANT UNDER HIGH PRESSURE. RECOVER REFRIGERANT TO RELIEVE PRESSURE BEFORE OPENING SYSTEM. Failure to follow proper procedures can result in personal illness or injury or severe equipment damage.

⚠ WARNING

Unit contains R-410A Refrigerant!
R-410A operating pressure exceeds the limit of R-22. Proper service equipment is required. Failure to use proper service tools may result in equipment damage or personal injury.
SERVICE
Use only R-410A Refrigerant and approved POE compressor oil.

⚠ WARNING

Improper Unit Lift!
Test lift unit approximately 24 inches to verify proper center of gravity lift point. To avoid dropping of unit, reposition lifting point if unit is not level. Failure to properly lift unit could result in death or serious injury or possible equipment or property-only damage.

⚠ CAUTION

RECONNECT ALL GROUNDING DEVICES.
All parts of this product that are capable of conducting electrical current are grounded. If grounding wires, screws, straps, clips, nuts, or washers used to complete a path to ground are removed for service, they must be returned to their original position and properly fastened.

⚠ CAUTION

Hot Surface!
Do Not touch top of compressor. May cause minor to severe burning.

⚠ CAUTION

Never use combustible cleaning fluids on any part of the furnace.

IMPORTANT: This product has been designed and manufactured to meet ENERGY STAR criteria for energy efficiency. However, proper refrigerant charge and proper air flow are critical to achieve rated capacity and efficiency. Installation of this product should follow the manufacturer's refrigerant charging and air flow instructions. Failure to confirm proper charge and airflow may reduce energy efficiency and shorten equipment life.

IMPORTANT: Do not connect gas piping to the unit until a line pressure test has been completed. This unit should never be exposed to gas line pressure in excess of 14 inches water column (1/2 PSIG). The furnace and its equipment shutoff valve must be disconnected from the gas supply piping system during any pressure testing of that system at test pressures in excess of 1/2 psi.

IMPORTANT: Reconnect all grounding devices. All parts of this product capable of conducting electrical current are grounded. If grounding wires, screws, straps, clips, nuts, or washers used to complete a path to ground are removed for service, they must be returned to their original position and properly fastened.

IMPORTANT: Wear appropriate gloves, arm sleeve protectors, and eye protection when servicing or maintaining this equipment.

IMPORTANT: Air filters and media wheels or plates shall meet the test requirements in UL 900.

Contents

Safety Considerations	2
Introduction	3
Step 1-Inspect Shipment	3
Step 2-Determine Unit Clearances	4
Step 3-Review Location and Recommendation Information	10
Step 4-Unit Installation	11
Install Flue Hood	11
Ground Level Installation	11
Rooftop Installation -- Curb Mounting	11
Covert Horizontal Airflow to Down Airflow	11
Install Full Perimeter Roof Mounting Curb	11
Lifting and Rigging	12
Placing the Unit on the Mounting Curb	12
Rooftop Installation -- Frame Mounting	13
Rooftop Installation -- No Curb/Fram	13
Ductwork Installation	16
Attaching Downflow Ductwork to Roof Curb	16
Attaching Downflow Ductwork to Roof Frame	16
Attaching Horizontal Ductwork to Unit	16
Condensate Drain Piping	16
Gas Piping Installation	17
Pipe Delivery Schedule (natural gas only)	17
Gas Pressure Set-up Precautions	17
Gas Supply Line Pressure (all fuels)	17
Verify Manifold Pressure	18
Input Check and Adjustment	18
High Altitude Installation	19
Air Filter Installation	19
Electrical Wiring	19
Electrical Connections	19
Electrical Power	19
Disconnect Switch	20
Over current Protection	20
Power Wiring	20
Control Wiring (Class II)	20
Thermostat Operation	20
Field Wiring Diagram	21
Step 5-Unit Startup	22
Pre-start Quick Checklist	22
Starting the Unit in the Cooling Mode	22
Operating Pressures	22
Voltage Check	22
Cooling Shutdown	22
Starting the Unit in Heat Pump Heating Mode	22
Gas Furnace Heating Cycle	22
Starting the Unit in Gas Heating Mode	23
Heating Shut-down	23
Final Installation Checklist	23
Sequence of Operation	24
Maintenance	26
Owner Maintenance	26
Service Maintenance	26
Cooling Season	26
Heating Season	26
Flue Hood and Combustion Blower Cleaning	27
ECM Fan Motor Adjustments	27
Status LEDs	28

Introduction

Read this manual carefully before attempting to install, operate, or perform maintenance on this unit. Installation and maintenance should be performed by qualified service technicians only. Do NOT use this furnace for temporary heating of buildings under construction.

As shipped from the factory, this unit is for use with natural gas only. It is listed by Underwriters Laboratory. An LP Gas conversion kit is available. Extreme mounting kits for slab and curbs are also available.

Packaged units are designed for outdoor mounting with a vertical condenser discharge. They can be located either at ground level or on a roof in accordance with local codes or National Fuel Gas Code (ANSI-Z223.1A) Latest Revision. Since these units are designed exclusively for outdoor operation, additional flue venting systems are not required. Each unit contains an operating charge of refrigerant as shipped. Extreme mounting kits are available for slab (BAYEX-MK003A), utility curb (BAYEXMK002B), or curb (BAYEX-MK001A) mountings.

The indoor fan motor speed adjustment is provided in the Service Maintenance section on page 26.

This guide is organized as follows:

- Step 1- Inspect Shipment
- Step 2- Determine Unit Clearances
- Step 3- Review Location and Recommendation Information
- Step 4- Unit Installation
- Step 5- Unit Startup
- Sequence of Operation
- Maintenance

Step 1—Inspect Shipment

- Check for damage after the unit is unloaded. Report promptly to the carrier any damage found to the unit. Do not drop the unit.
IMPORTANT: To prevent damage to the sides and top of the unit when hoisting, use "spreader bars" as shown on page 13.
- Check the unit's nameplate to determine if the unit is correct for the intended application. The power supply must be adequate for the unit and all accessories.
- Check to be sure the refrigerant charge has been retained during shipment. Remove the Compressor access panel to access the 1/4" flare pressure taps.
- The Flue Hood is included with the unit's literature pack.
- If this unit is being installed on a curb, verify that the correct curb is provided for the unit.
 - 4DCL4024-036 use model BAYCURB050A.
 - 4DCL4042-060 use model BAYCURB051A.
- If the unit is being hoisted, accessory kit BAYLIFT002B is recommended. It includes a kit of four (4) lifting lugs and instructions.

NOTE: If practical, install any internal accessories to the unit at the shop.

NOTE: The packaged units have been evaluated in accordance with the Code of Federal Regulations, Chapter XX, Part 3280 or the equivalent. "SUITABLE FOR MOBILE HOME USE".

Installer's Guide

Step 2—Determine Unit Clearances

Figures 1 through 6 show the unit critical dimensions.

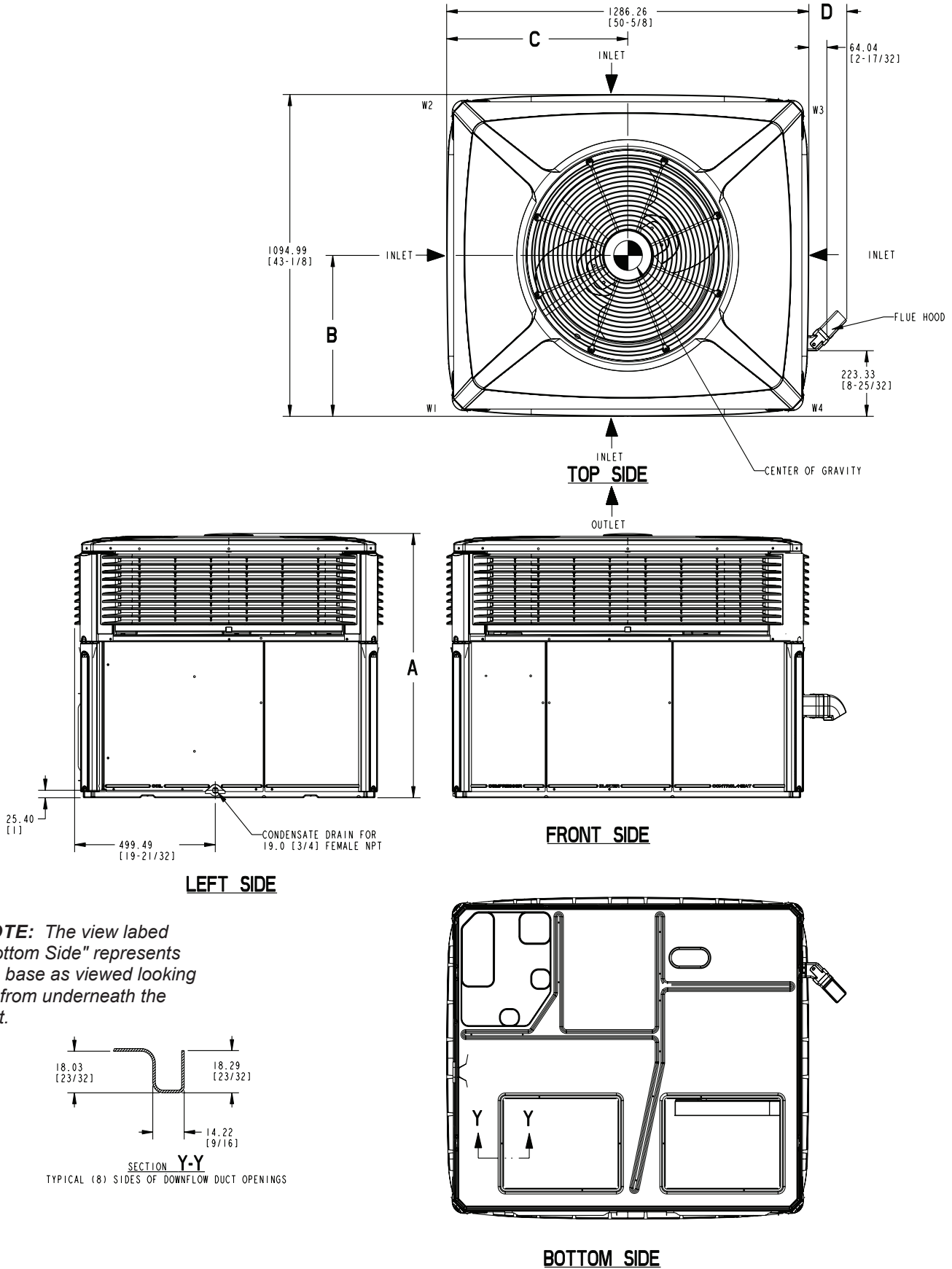
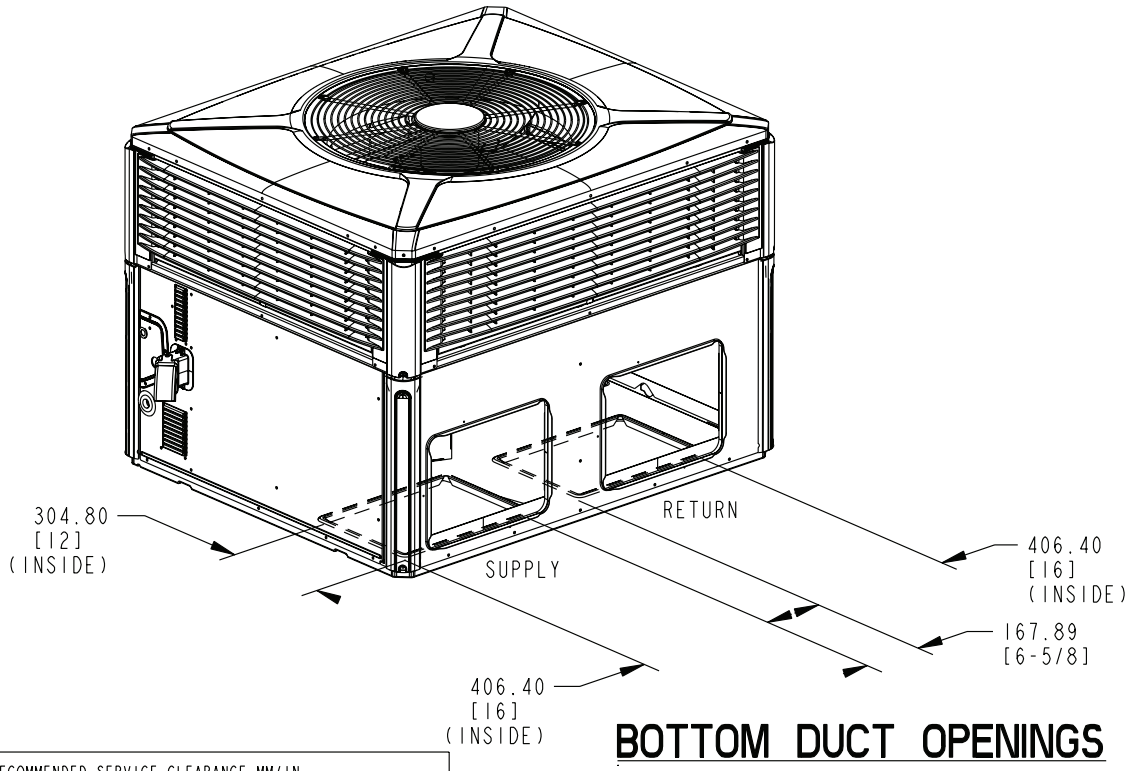

Figure 1. 4DCL4024 through 4DCL4036 (1 of 3)



BOTTOM DUCT OPENINGS

RECOMMENDED SERVICE CLEARANCE MM/IN.		
		WITH ECONOMIZER
BACK SIDE	304.8 [12]	762.0 [30]
LEFT SIDE	762.0 [30]	914.4 [36]
RIGHT SIDE	914.4 [36]	-
FRONT SIDE	1066.8 [42]	-

CLEARANCE TO COMBUSTIBLE MATERIAL MM/IN.	
BOTTOM	0
BACK SIDE	25.4 [1]
LEFT SIDE	152.4 [6]
RIGHT SIDE	304.8 [12]
FRONT SIDE	304.8 [12]
TOP	914.4 [36]

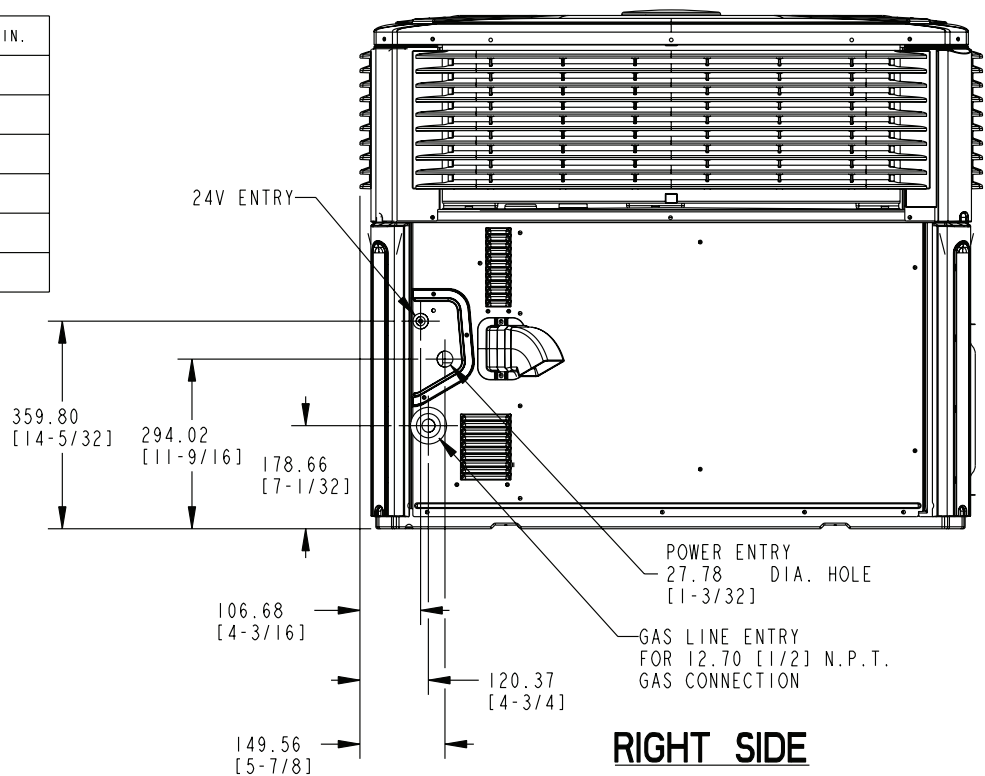
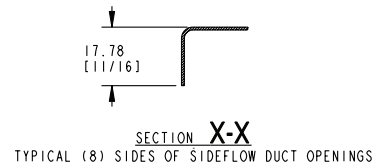
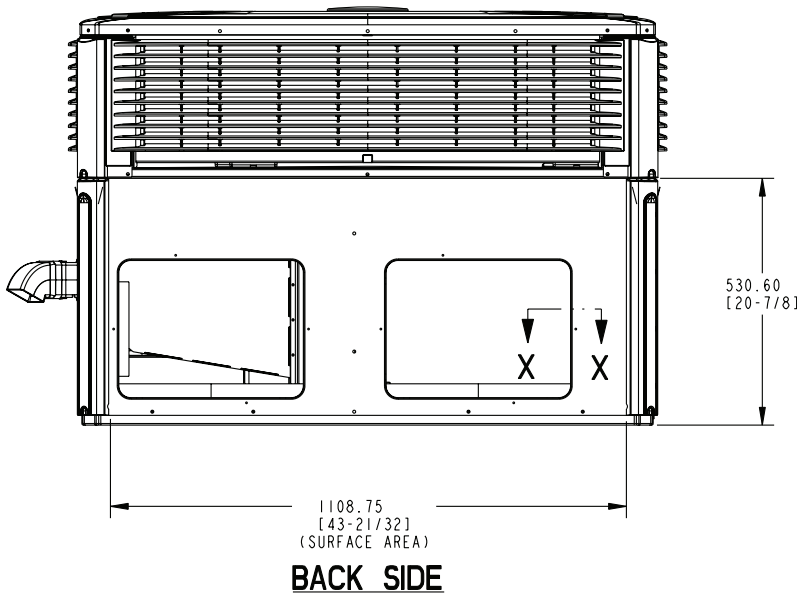
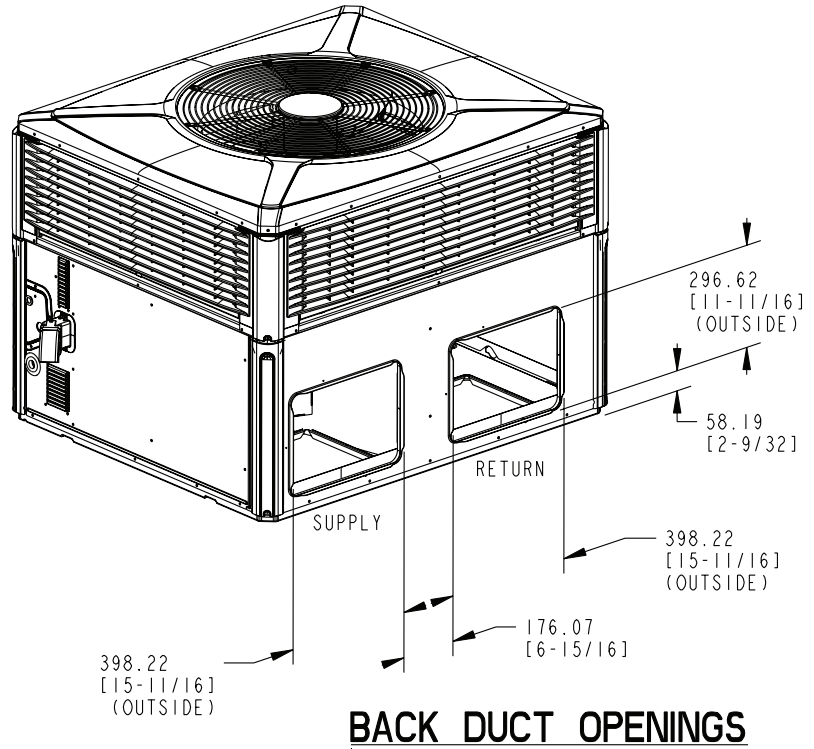

Figure 2. 4DCL4024 through 4DCL4036 (2 of 3)



MODEL	HEIGHT MM/IN.		FLUE HOOD W/BRKT MM/IN.	APPROX. CORNER WEIGHT - KG/LBS				SHIPPING WEIGHT KG/LBS	TOTAL UNIT WEIGHT KG/LBS	CENTER OF GRAVITY MM/IN.	
	A	D		W1	W2	W3	W4			B	C
4DCL4024 (060)	903.29 [35-9/16]	-	117.86 [4-5/8]	60.8 [134]	38.1 [84]	31.3 [69]	48.5 [107]	218.4 (481)	174.8 [385]	398.8 [15.7]	546.1 [21.5]
4DCL4030 (070)											
4DCL4036/4DCL6036 (070)	949.99 [37-3/8]			62.1 [137]	37.2 [82]	30.4 [67]	50.3 [111]	221.6 (488)	178.0 [392]	386.1 [15.2]	558.8 [22.0]

Figure 3. 4DCL4024 through 4DCL4036 (3 of 3)

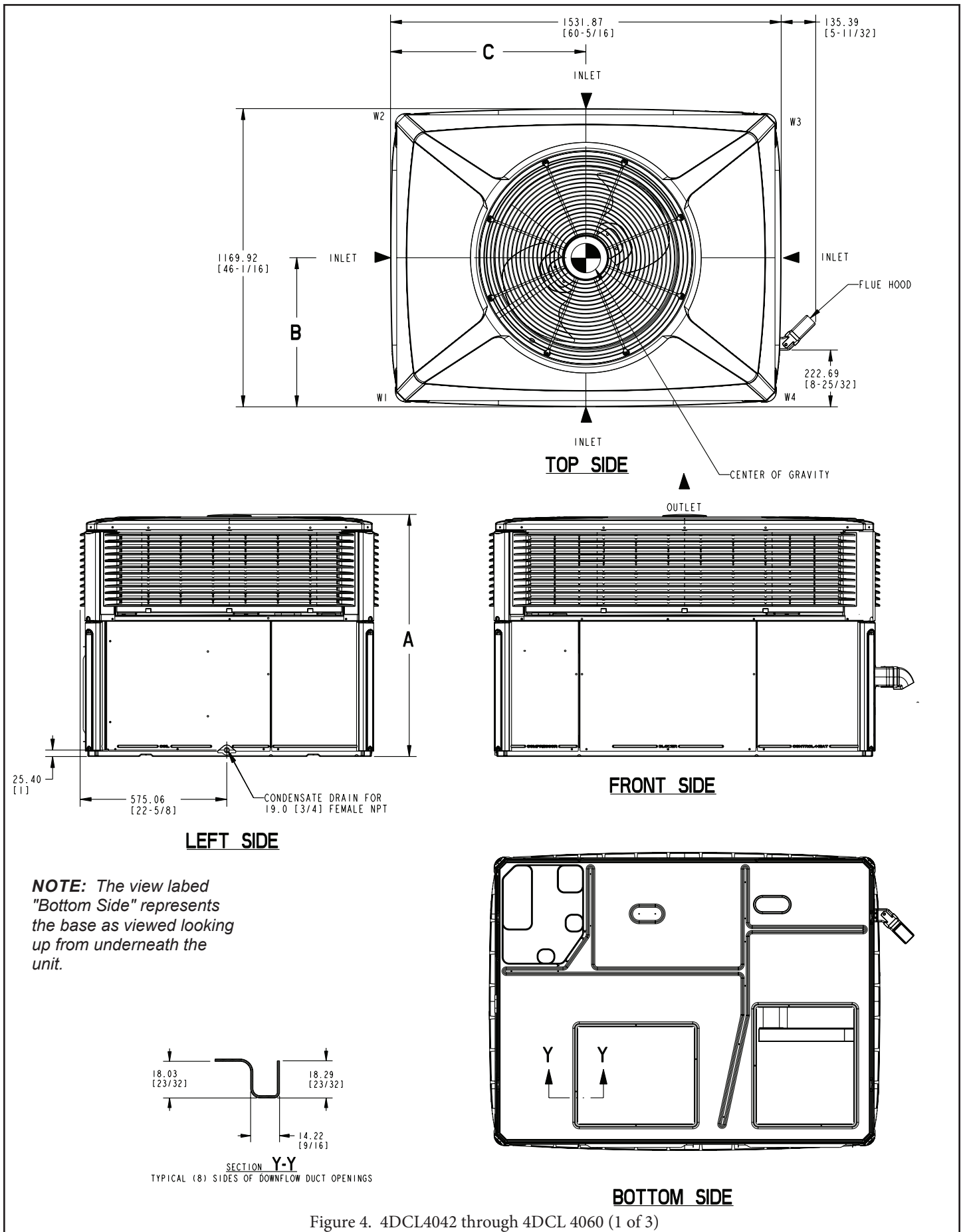
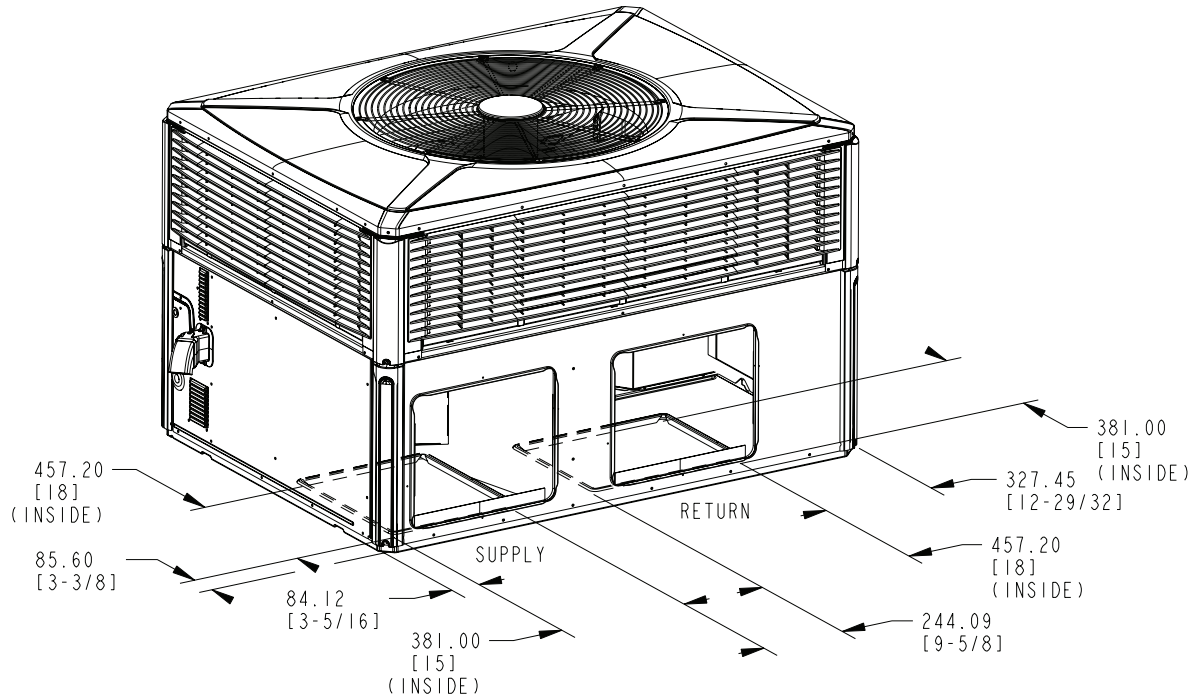

Figure 4. 4DCL4042 through 4DCL 4060 (1 of 3)



BOTTOM DUCT OPENINGS

RECOMMENDED SERVICE CLEARANCE MM/IN.		
		WITH O.A. DAMPER/ECON.
BACK SIDE	304.8 [12]	762.0 [30]
LEFT SIDE	914.4 [36]	1066.8 [42]
RIGHT SIDE	914.4 [36]	-
FRONT SIDE	1066.8 [42]	-

CLEARANCE TO COMBUSTIBLE MATERIAL MM/IN.	
BOTTOM	0
BACK SIDE	25.4 [1]
LEFT SIDE	152.4 [6]
RIGHT SIDE	304.8 [12]
FRONT SIDE	304.8 [12]
TOP	914.4 [36]

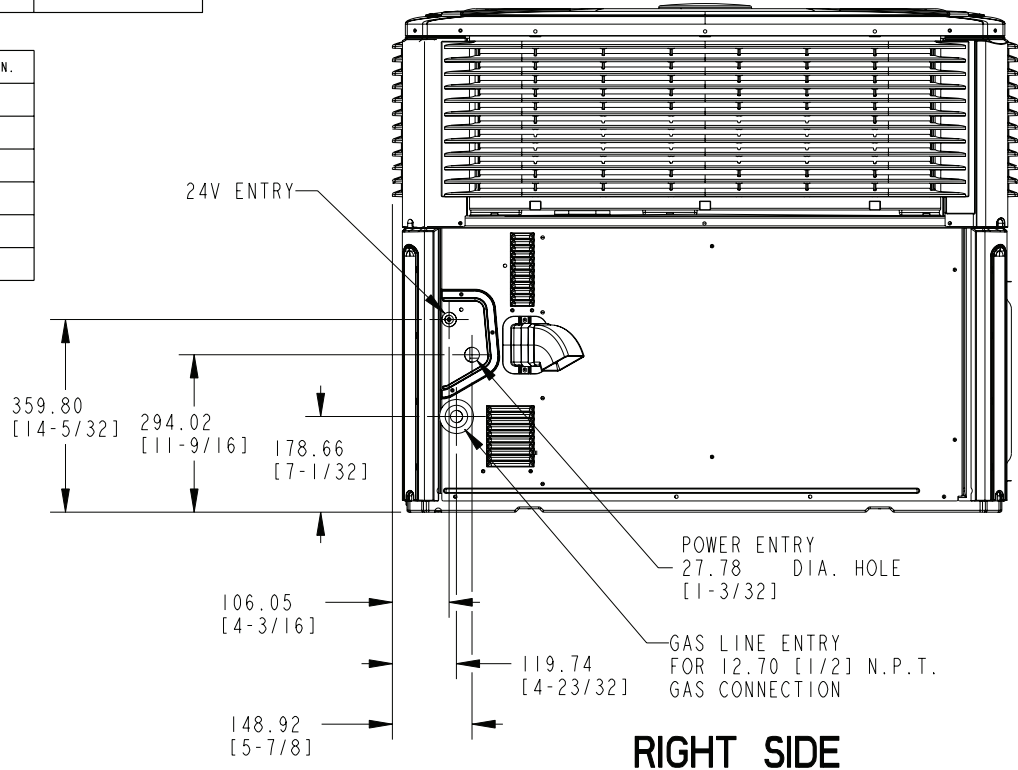

RIGHT SIDE

Figure 5. 4DCL4042 through 4DCL4060 (2 of 3)

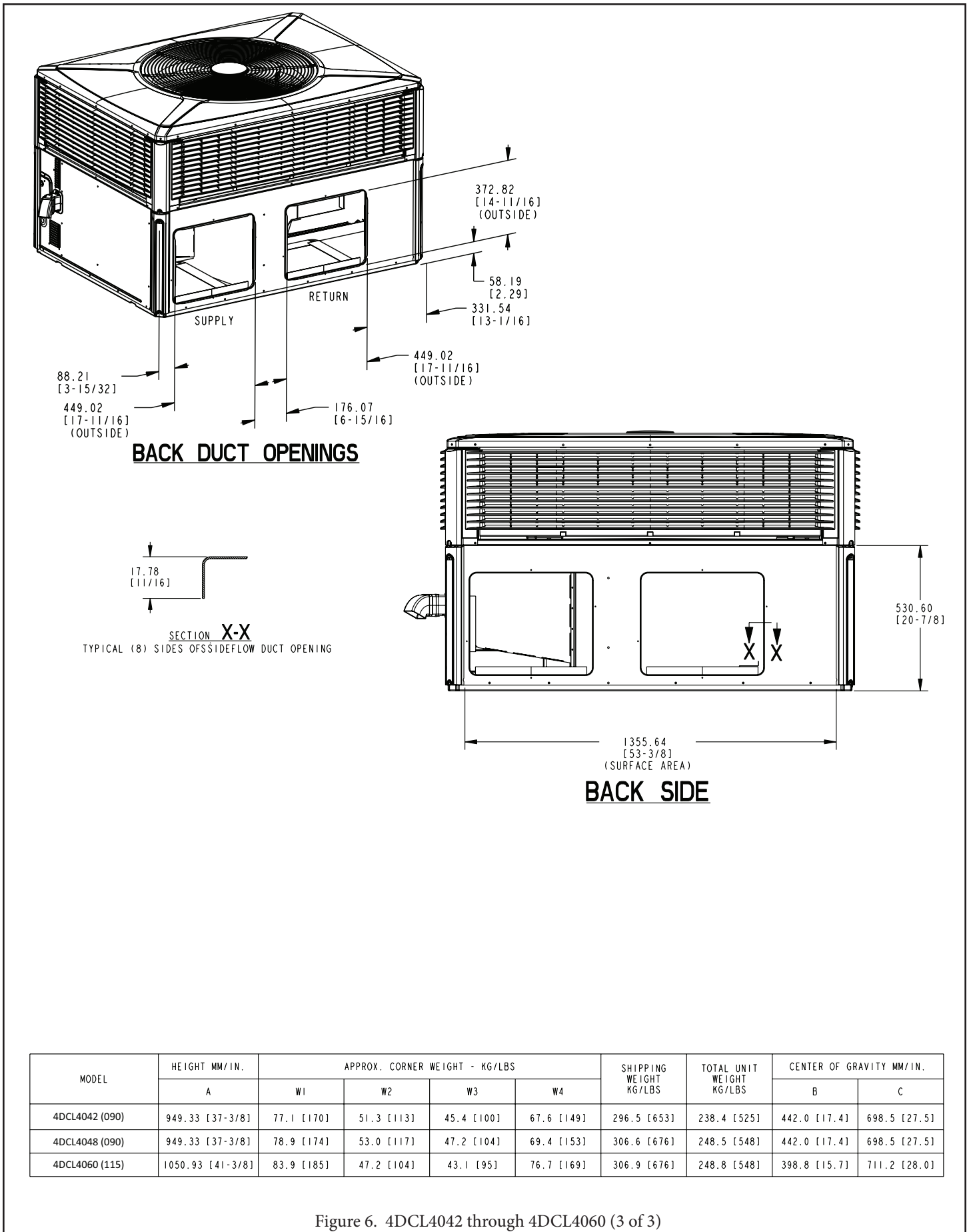

MODEL	HEIGHT MM/IN.	APPROX. CORNER WEIGHT - KG/LBS				SHIPPING WEIGHT KG/LBS	TOTAL UNIT WEIGHT KG/LBS	CENTER OF GRAVITY MM/IN.	
	A	W1	W2	W3	W4			B	C
4DCL4042 (090)	949.33 [37-3/8]	77.1 [170]	51.3 [113]	45.4 [100]	67.6 [149]	296.5 [653]	238.4 [525]	442.0 [17.4]	698.5 [27.5]
4DCL4048 (090)	949.33 [37-3/8]	78.9 [174]	53.0 [117]	47.2 [104]	69.4 [153]	306.6 [676]	248.5 [548]	442.0 [17.4]	698.5 [27.5]
4DCL4060 (115)	1050.93 [41-3/8]	83.9 [185]	47.2 [104]	43.1 [95]	76.7 [169]	306.9 [676]	248.8 [548]	398.8 [15.7]	711.2 [28.0]

Figure 6. 4DCL4042 through 4DCL4060 (3 of 3)

Installer's Guide

Step 3—Review Location and Recommendation Information

NOTE: The unit is shipped for horizontal installation.

NOTE: During heating operation, avoid supply air below 80 degrees F or return air below 50 degrees F to prevent flue gas condensation.

Horizontal Airflow Units

1. Location of the unit must allow service clearance around it to ensure adequate serviceability, maximum capacity, and peak operating efficiency.
2. These units are designed for outdoor installation. They may be installed directly on a slab, wood flooring, or on Class A, B, or C roof covering material. The discharge air from the condenser fans must be unrestricted for a minimum of 3 feet above the unit.
3. The louvers above and below the flue hood in the side panel must have adequate clearance around the air opening into the combustion area. See Figure 2 on page 5 or Figure 4 on page 7.
4. Examine all flue product-carrying areas of the furnace, its vent system, and the main burner for safe operation.

IMPORTANT: A minimum 0" clearance to combustible material shall be maintained on air outlet duct.

5. Exhaust vents or other sources of contaminated air must not be near the unit's air inlet if outside air is to be introduced as make-up air or a ventilation feature is to be used. Contamination from exhaust vents or chimneys may also foul the condenser causing degraded performance.
6. Check the handling facilities to ensure the safety of personnel and the unit(s).
7. The unit must be mounted level for proper drainage of water through the drain holes in the base pan.
8. The unit should not be exposed to direct roof water runoff.
9. Flexible duct connectors must be of a flame retardant material. All duct work outside of the structure must be insulated and weatherproofed in accordance with local codes.
10. Holes through exterior walls or roof must be sealed in accordance with local codes.
11. All fabricated outdoor ducts should be as short as possible.

Clearances

1. The recommended clearances for single-unit installations are illustrated in Figures 1 to 6, pages 4-9.
2. Any reduction of the unit clearances indicated in these figures may result in condenser coil starvation or the recirculation of warm condenser air. Actual clearances, which appear to be inadequate should be reviewed with a local engineer.
3. See the unit's nameplate for the absolute minimum clearance between the unit and any combustible surfaces.

Down Airflow Units

1. Location of the unit must allow service clearance around it to ensure adequate serviceability, maximum capacity, and peak operating efficiency.
2. Refer to the Installation section for instruction on converting the supply and return airflow covers to down airflow.
3. The field assembled Roof Mounting Curb (BAYCURB050A or BAYCURB051A) or a field fabricated curb should be in place before the unit is hoisted to the roof top.

The Roof Mounting Curb (frame) must be installed on a flat, level section of the roof (maximum of 1/4" per foot pitch) and provide a level mounting surface for the unit. Also, be sure to provide sufficient height above the roof to prevent water from entering the unit.

4. Be sure the mounting curb spans structural members (trusses) of the roof, thereby providing sufficient support for the weight of the unit, the curb, the duct(s), and any factory or field installed accessories.
 5. The unit must be mounted level for proper drainage of water through the drain holes in the base pan.
 6. Be sure the hole in the structure for the ducts is large enough to accommodate the fabricated ducts and the insulation surrounding them. Flexible duct connectors must be of a flame retardant material. All duct work outside of the structure must be insulated and weatherproofed in accordance with local codes.
 7. Holes through exterior walls or roof must be sealed in accordance with local codes.
 8. These units are designed for outdoor installation. They may be installed directly on a slab, wood flooring, or on Class A, B, or C roof covering material. The discharge air from the condenser fans must be unrestricted for a minimum of 3 feet above the unit.
 9. The louvers above and below the flue hood in the side panel must have adequate clearance around the air opening into the combustion area.
 10. Examine all flue product-carrying areas of the furnace, its vent system, and the main burner for safe operation.
- IMPORTANT:** A minimum 0" clearance to combustible material shall be maintained on air outlet duct.

11. Exhaust vents or other sources of contaminated air should not be near the unit's air inlet if outside air is to be introduced as make-up air or a ventilation feature is to be used. Contamination from exhaust vents or chimneys may also foul the condenser causing degraded performance.
12. Check the handling facilities to ensure the safety of personnel and the unit(s).

Clearances

1. The recommended clearances for single-unit installations are illustrated in Figures 1 to 6, pages 4-9.
2. Any reduction of the unit clearances indicated in these figures may result in condenser coil starvation or the recirculation of warm condenser air. Actual clearances, which appear to be inadequate should be reviewed with a local engineer.
3. See the unit's nameplate for the absolute minimum clearance between the unit and any combustible surfaces.

Step 4—Unit Installation

NOTE: The factory ships this unit for horizontal installation.

Install Flue Hood

1. Locate the Flue Hood in the literature package.
2. Remove the two Flue Hood mounting screws from the unit. They are located to the right of the Power Entry connection panel.
3. Attach the Flue Hood to the unit with the two screws removed in step 2. See Figure 2 on page 5 or Figure 5 on page 8 for correct orientation of the Flue Hood.

Ground Level Installation

To install the unit at ground level:

1. Place the unit on a pad the size of the unit or larger. The unit must be mounted level for proper drainage of water through the holes in the base pan. To securely attach the unit to the slab, use extreme mounting kit, BAYEXMK003A.

The pad must not come in contact with the structure (see Figure 7.) Be sure the outdoor portion of the supply and return air ducts are as short as possible.

Unit requires vibration support as indicated in Figure 7 below and in Figure 9 on page 13.

2. The louvers above and below the Flue Hood in the side panel must have adequate clearance around the air opening into the combustion area.
3. Location of the unit must allow service clearance around it. Clearance of the unit must be given careful consideration. See Figures 1 to 6, pages 4-9.

NOTE: Any reduction of the unit clearances indicated in these illustrations may result in condenser coil starvation or the recirculation of warm condenser air. Actual clearances, which appear to be inadequate should be reviewed with a local engineer.

IMPORTANT: A minimum 0" clearance to combustible material shall be maintained on air outlet duct.

4. Attach the supply and return air ducts to the unit as explained in the following Ductwork Installation section on page 16.
5. Flexible duct connectors must be of a flame retardant material. Insulate any ductwork outside of the structure with at least two (2) inches of insulation and weatherproof. There must be a weatherproof seal where the duct enters the structure.
6. Do not expose the unit to direct roof water runoff.
7. Seal all holes through exterior walls in accordance with local codes.
8. Continue with the following installation sections to complete the installation: Ductwork on page 16, Gas Piping on page 17, Filter on page 19, and Electrical Wiring on page 19.

Rooftop Installation -- Curb Mounting

Convert Horizontal Airflow to Down Airflow

The factory ships the unit for horizontal airflow. Perform this procedure to convert the unit to down airflow:

1. Remove the three (3) sheet metal screws securing the supply air cover and the four (4) sheet metal screws securing the return air cover from the base of the unit. Remove the covers from the base. See Figure 8, page 12.
2. Place the covers over the horizontal supply and return openings (painted side out). Align the screw holes, and secure using the same screws removed in step 1.

Install Full Perimeter Roof Mounting Curb

1. Verify that the roof mounting curb is correct for the unit. There are two curbs depending on the unit cabinet sizes:
 - 4DCL4024 through 4DCL4036 use model BAYCURB050A.
 - 4DCL4042 through 4DCL4060 use model BAYCURB051A.
2. Assemble and install the curb following the instructions in the Installer's Guide included with the curb.

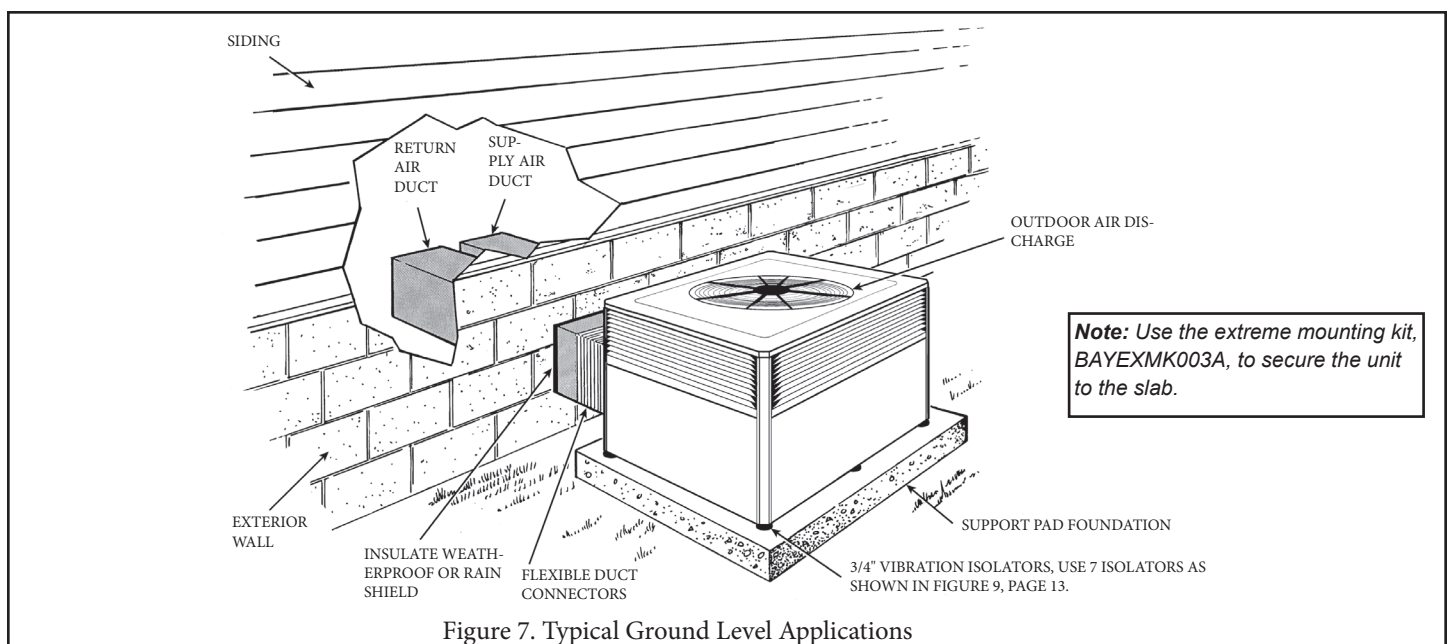

Figure 7. Typical Ground Level Applications

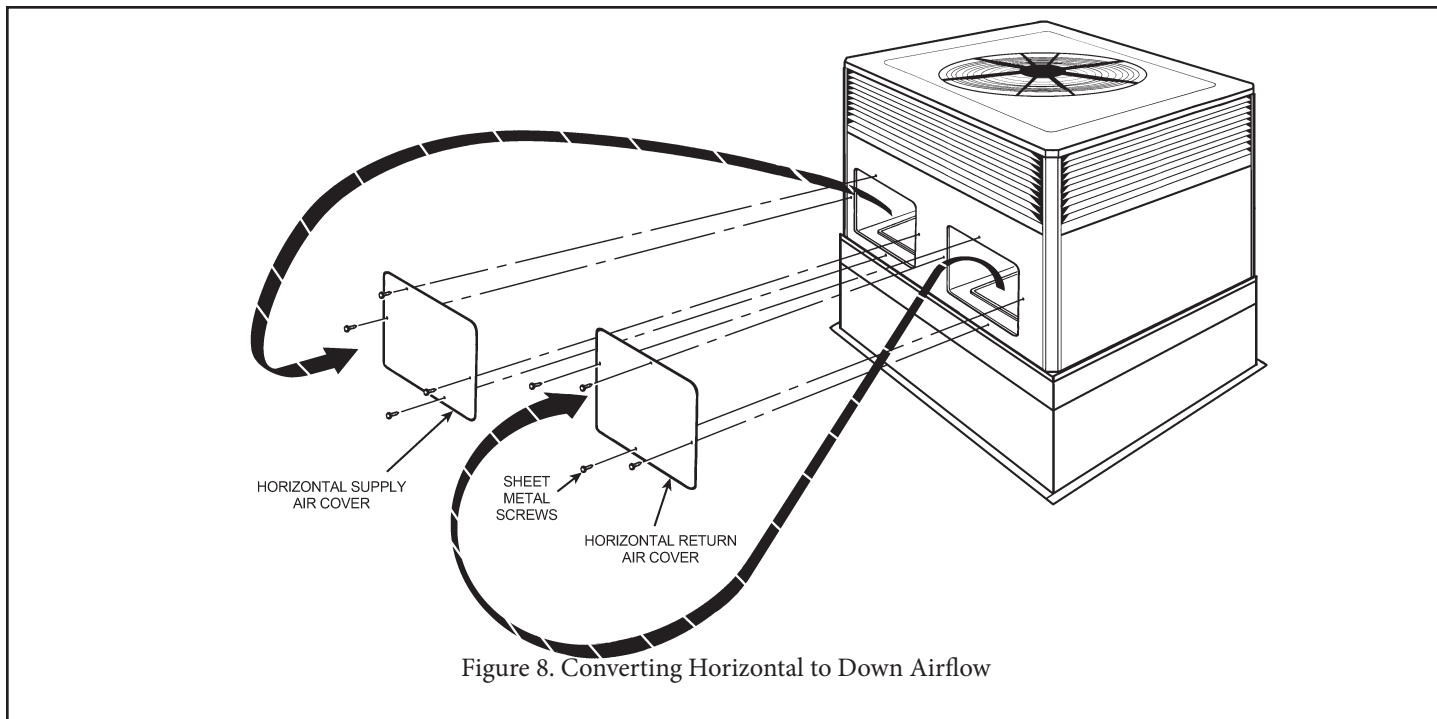

Figure 8. Converting Horizontal to Down Airflow

Lifting and Rigging

⚠ WARNING**Improper Unit Lift!**

Test lift unit approximately 24 inches to verify proper center of gravity lift point. To avoid dropping of unit, reposition lifting point if unit is not level. Failure to properly lift unit could result in death or serious injury or possible equipment or property-only damage.

IMPORTANT: Do not lift the unit without test lifting for balance and rigging. Do not lift the unit in windy conditions or above personnel. Do not lift the unit by attaching clevis, hooks, pins, or bolts to the unit casing, casing hardware, corner lugs, angles, tabs, or flanges. Failure to observe these warnings may result in equipment damage.

1. Before preparing the unit for lifting, check the unit dimension drawings for center of gravity for lifting safety (Figures 1 to 6, page 4-9). Because of placement of internal components, the unit's weight may be unevenly distributed. Approximate unit weights are also provided in the unit drawings.

NOTE: When unit rigging and hoisting it is recommended that accessory kit BAYLIFT002B be used. It includes a kit of four (4) lifting lugs. See Figure 10 inset B, on page 14.

2. Insert the four lifting lugs in the openings provided in the drip lip on each end of the unit. See Figure 10 inset B on page 14. A tap or jerk to the lug will overcome the interference that arises due to the dimple on the lug.
3. When hoisting the unit, be sure that a proper method of rigging is used. Use straps or slings and spreader bars for protection during lifting. Always test-lift the unit to determine the exact unit balance and stability before hoisting it to the installation location.
4. When the curb and air ducts have been properly installed, the unit is ready to be hoisted to the roof and set in position.

IMPORTANT: The unit must be lowered into position. The P.V.C. rubber tape on the curb flange permits the unit to be repositioned if required without destroying the P.V.C. rubber seal affixed to the mounting curb.

Placing the Unit on the Mounting Curb

1. The unit is designed with a perimeter drip lip that is lower than the unit base pan, see Figure 10, inset A, on page 14.
2. Position the unit drip lip down over and in contact with the outside corner of the curb, as illustrated in Figure 10, inset A, on page 14. Continue to lower the unit on top of the curb, with the unit drip lip astraddle, and in contact with, both the end and side rail of the curb. The unit should now rest on top of the curb. Use the extreme mounting kit, BAYEXMK001A, to add additional hold down strength to the mounting.

NOTE: The ductwork is installed as part of the curb installation. Do not attach ductwork to the unit and lower the unit with ductwork onto the curb.

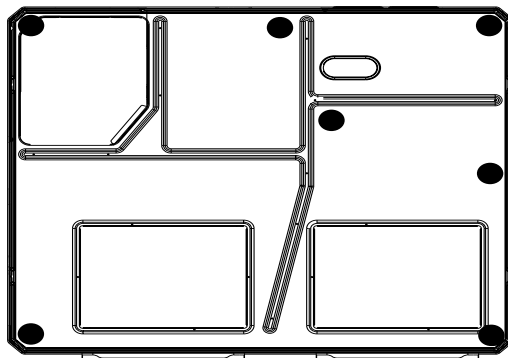

Small Cabinet
****018-036

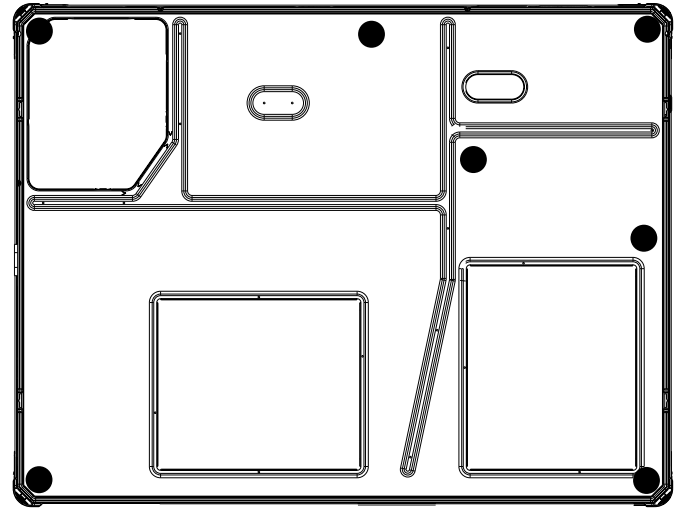

Medium Cabinet
****042-060

NOTE: These views represent the base as viewed looking up from underneath the unit.

IMPORTANT: Unit requires vibration isolator supports in the general areas shown. Locate 3/4" thick vibration isolators on the bottom of the basepan as illustrated by black dots for ground level pad applications. Modify vibration isolator location as necessary for frame and rail applications.

Figure 9. Vibration Isolators/Snow Feet Locations

Rooftop Installation -- Frame Mounting

For roof top applications using field fabricated frame and ducts, use the following procedure:

1. Locate and secure the frame to the roof by bolting or welding. Frame must provide adequate center support via a cross member centrally located channel rail. See Figures 12 and 13 on page 15. Vibration isolators should be installed as indicated in Figure 9, adjust as necessary for your frame. The isolators must be placed on base pan, not drip lip. Add flashing as required. Flashing must conform to local building codes.
2. Prepare the hole in the roof in advance of installing the unit.
3. Secure the horizontal or down airflow ducts to the roof. Refer to the previous Convert from Horizontal Airflow to Down Airflow section on page 11, if conversion is needed.
4. All fabricated outdoor ducts should be as short as possible.
5. Place the unit on the frame. Refer to Figures 12 or 13 on page 14.
6. The unit must be mounted level for proper drainage of water through the holes in the base pan.
7. Secure the unit to the frame.
8. Insulate any ductwork outside of the structure with at least two (2) inches of insulation and then weatherproof. There must be a weatherproof seal where the duct enters the structure.
9. The unit should not be exposed to direct roof water runoff.
10. Flexible duct connectors must be of a flame retardant material. All duct work outside of the structure must be insulated and weatherproofed in accordance with local codes.
11. Access and service clearances for the unit must be given careful consideration when locating the duct entrance openings. Figures 1 to 6, on pages 4-9, provide unit dimensions.
12. Continue with the following installation sections to complete the installation: Ductwork on page 16, Gas Piping on page 17, Filter on page 19, and Electrical Wiring on page 19.

Rooftop Installation -- Flat Roof - No Curb/Frame

For roof top applications using field fabricated ducts and sleeper rails rather than a curb or frame, use the following procedure:

1. Locate and secure the sleeper rails to the roof. Three (3) sleeper rails are required. One on each end to support the edges of the unit and one across the center of the unit. The center rail must run inside both drip lips. Vibration isolators should be installed as indicated on Figure 9, adjust as necessary for your sleeper rails. The isolators must be placed on base pan, not drip lip. Add flashing as required. Flashing must conform to local building codes.
2. Prepare the hole in the roof in advance of installing the unit.
3. Secure the horizontal or down airflow ducts to the roof. Refer to the previous Convert from Horizontal Airflow to Down Airflow section on page 11, if conversion is needed.
4. All fabricated outdoor ducts should be as short as possible.
5. Place the unit on the rails.
6. The unit must be mounted level for proper drainage of water through the holes in the base pan.
7. Secure the unit to the rails.
8. Insulate any ductwork outside of the structure with at least two (2) inches of insulation and then weatherproof. There must be a weatherproof seal where the duct enters the structure.
9. The unit should not be exposed to direct roof water runoff.
10. Flexible duct connectors must be of a flame retardant material. All duct work outside of the structure must be insulated and weatherproofed in accordance with local codes.
11. Access and service clearances for the unit must be given careful consideration when locating the duct entrance openings. Figures 1 to 6, on pages 4-9, provide unit dimensions.
12. Continue with the following installation sections to complete the installation: Ductwork on page 16, Gas Piping on page 17, Filter on page 19, and Electrical Wiring on page 19.

Installer's Guide

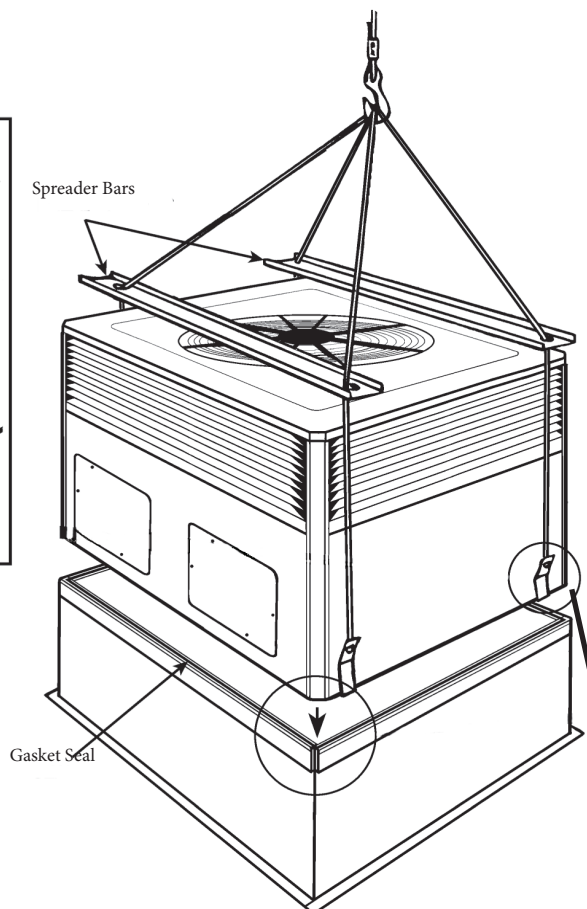
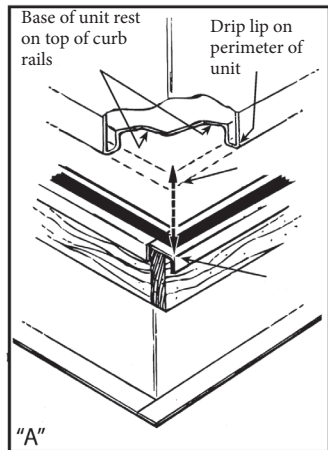

IMPORTANT: To prevent damage to the sides and top of the unit when hoisting, use "spreader bars" as shown in these illustrations.

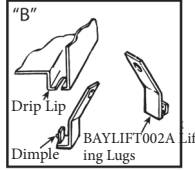
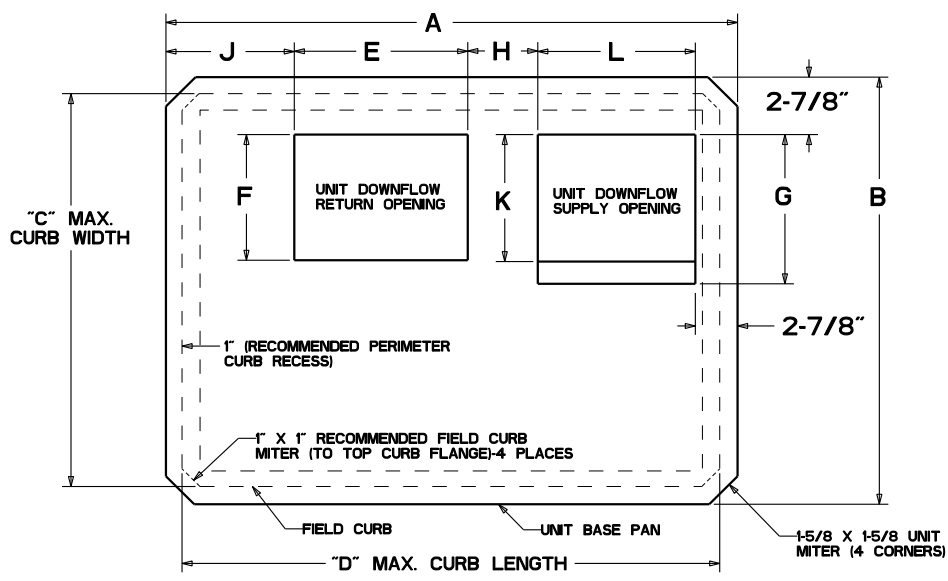

Figure 10. Lifting and Rigging



TOP VIEW OF UNIT BASE PAN WITH FIELD CURB BELOW
REFERENCE ILLUSTRATION FOR A CUSTOMER SUPPLIED ROOF CURB

PRINTED FROM D674152

MODEL	A	B	C	D	E	F	G	H	J	K	L
4 TC*,YC*,WC*,DC*018,024,030,036	48-3/8	40-7/8	38-7/8	46-3/8	16	12	6-5/8	6-7/8	12	16	
4 TC*,YC*,WC*,DC*042,048,060	58	43-7/8	41-7/8	56	18	15	9-5/8	12-1/2	15		

This drawing was prepared by the manufacturer in order to provide detail regarding job layout only. This drawing is not intended to be used as a basis to construct, build or modify the item depicted in the drawing. The manufacturer is not responsible for the unauthorized use of this drawing and expressly disclaims any liability for damages resulting from such unauthorized use.

Figure 11. Curb Dimensions

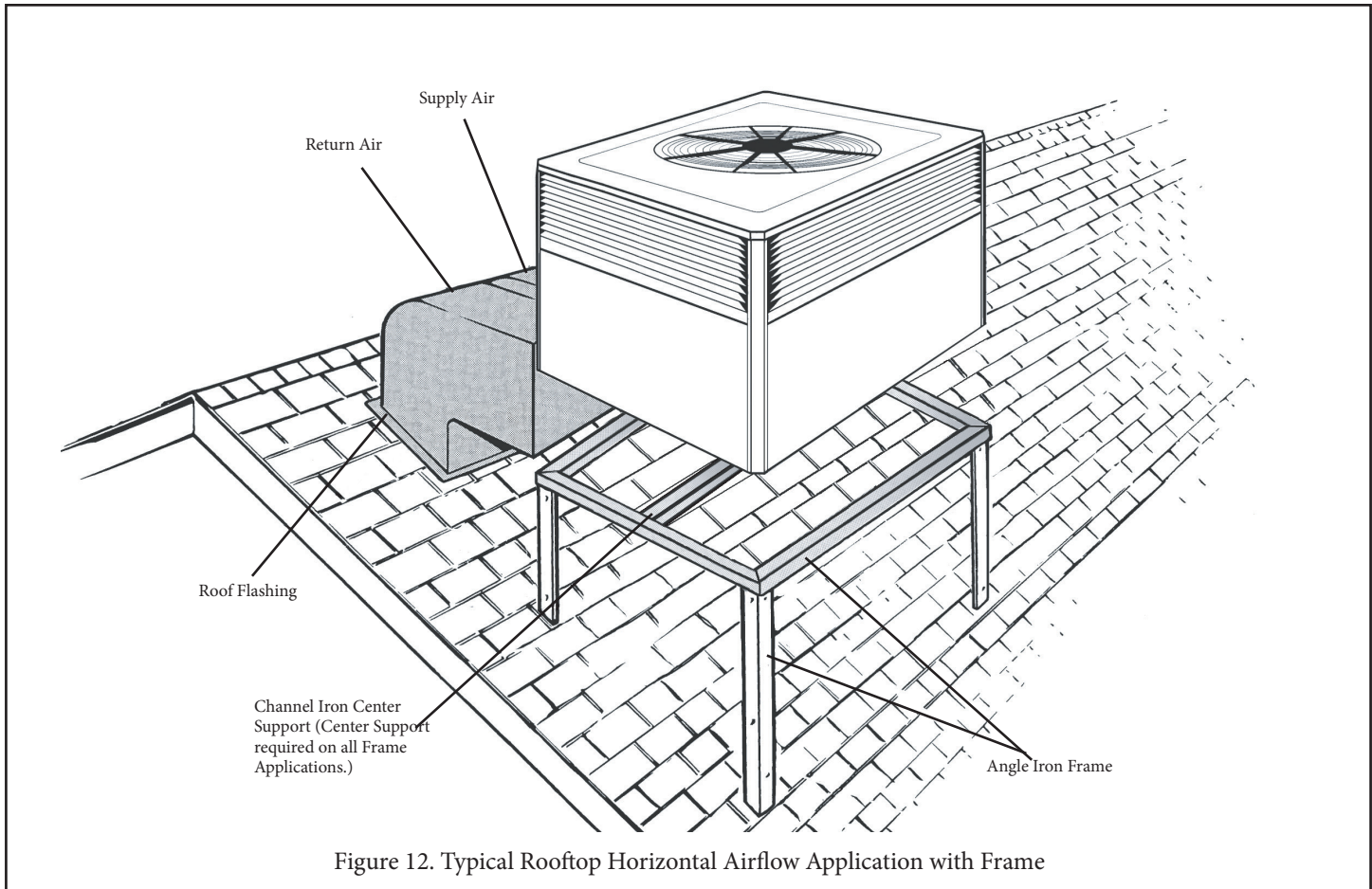

Figure 12. Typical Rooftop Horizontal Airflow Application with Frame

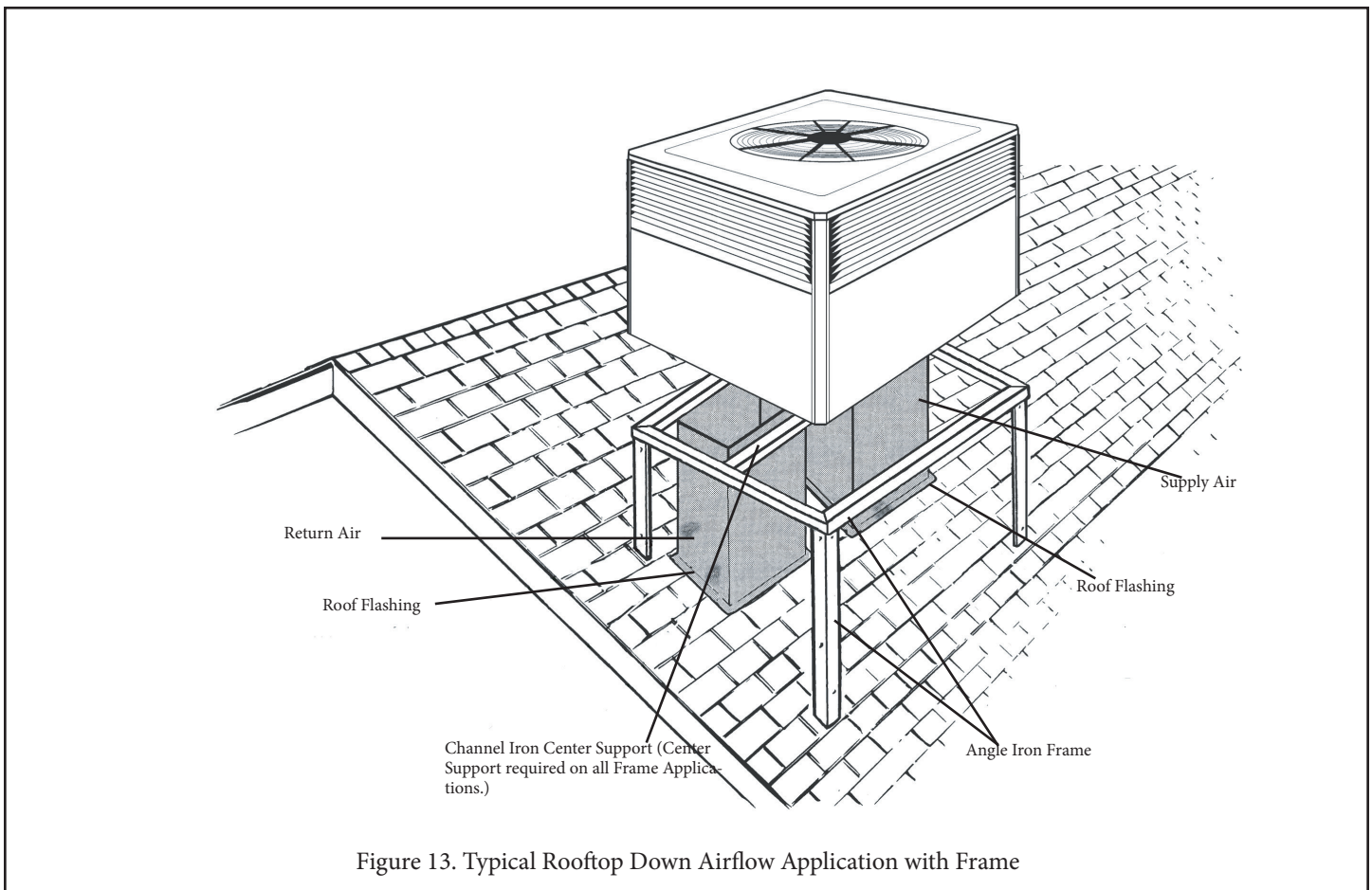

Figure 13. Typical Rooftop Down Airflow Application with Frame

Installer's Guide

Ductwork Installation

Attaching Downflow Ductwork to Roof Curb

Supply and return air flanges are provided on the BAYCURB050 and BAYCURB051 model roof curbs for easy duct installation. All ductwork must be run and attached to the curb before the unit is set into place.

Attaching Downflow Ductwork to Roof Frame

Follow these guidelines for ductwork construction:

Connections to the unit should be made with three (3) inch canvas connectors to minimize noise and vibration transmission.

Elbows with turning vanes or splitters are recommended to minimize air noise and resistance.

The first elbow in the ductwork leaving the unit should be no closer than two (2) feet from the unit to minimize noise and resistance.

To prevent leaking, do not attach the ductwork to the bottom of the unit base; refer to the bottom example in Figure 14.

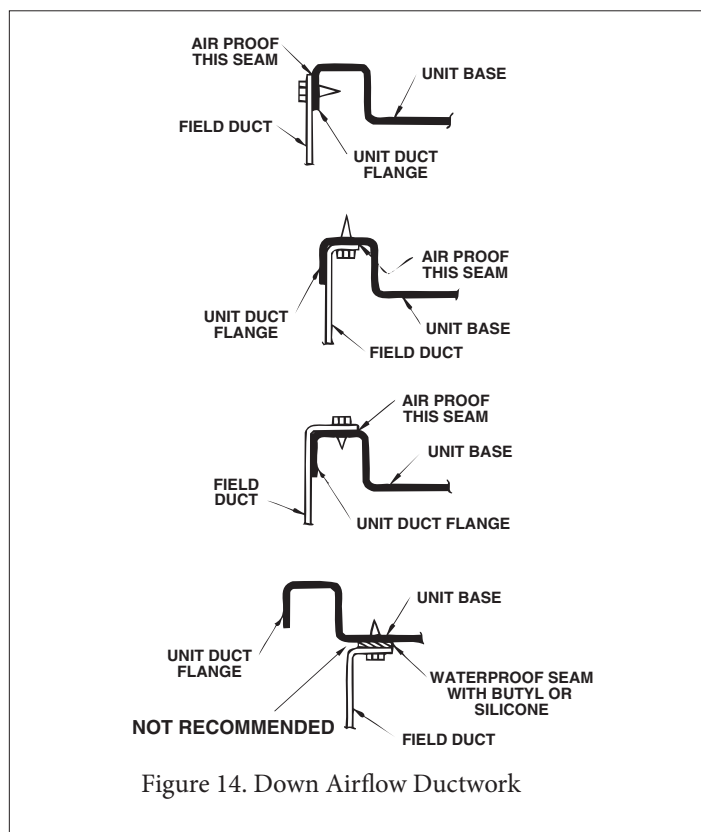

Attaching Horizontal Ductwork to Unit

All conditioned air ductwork should be insulated to minimize heating and cooling duct losses. Use a minimum of two (2) inches of insulation with a vapor barrier. The outside ductwork must be weatherproofed between the unit and the building.

When attaching ductwork to a horizontal unit, provide a flexible watertight connection to prevent noise transmission from the unit to the ducts. The flexible connection must be indoors and made out of heavy canvas.

NOTE: Do not draw the canvas taut between the solid ducts.

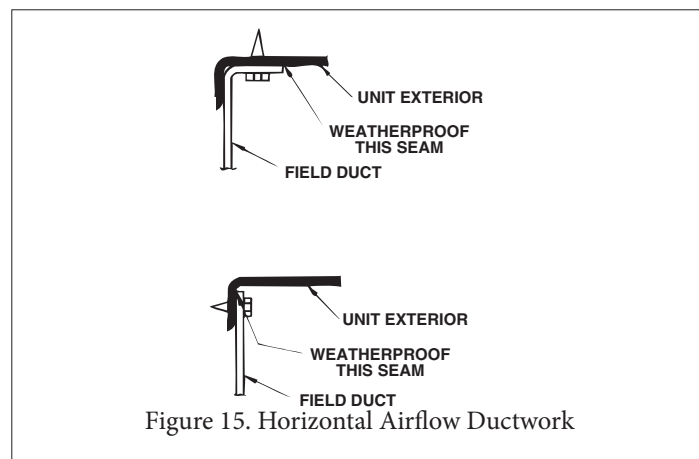

Condensate Drain Piping

A 3/4-inch female NPT condensate drain connection is provided on the filter access panel end of the unit. Provide a trap and fill it with water before starting the unit to avoid air from being drawn through. Follow local codes and standard piping practices when running the drain line. Pitch the line downward away from the unit. Avoid long horizontal runs. See Figure 16.

NOTE: Do not use reducing fittings in the drain lines.

The condensate drain must be:

- ☒ Made of 3/4" pipe.
- ☒ Pitched 1/4" per foot to provide free drainage to convenient drain system.
- ☒ Trapped.
- ☒ Must not be connected to a closed drain system unless the trap is properly vented.

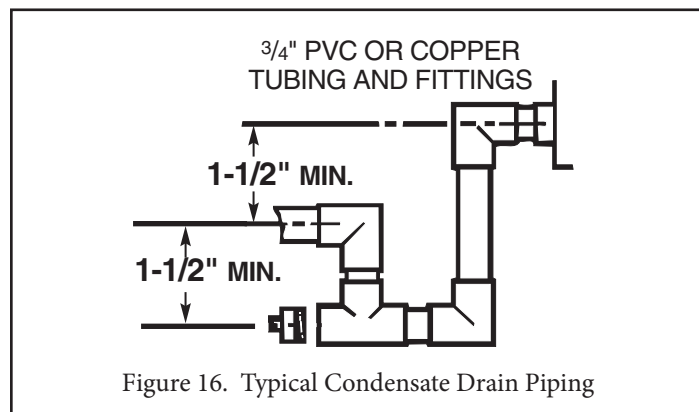

Gas Piping Installation

⚠ WARNING

FIRE OR EXPLOSION HAZARD!

Failure to follow the safety warning exactly could result in serious injury, death, or property damage. Never test for gas leaks with an open flame. Use a commercially available soap solution made specifically for the detection of leaks to check all connections. A fire or explosion may result causing property damage, personal injury or loss of life.

IMPORTANT: Before making the gas pipe connection give serious consideration to providing the clearance necessary to remove the access panels on the unit (e.g., economizer and filter access panels).

NOTE: In the absence of local codes, the installation must conform with American National Standard--Z223.1--National Fuel Gas Code, Latest Revision.

The available gas supply must agree with the required gas supply marked on the unit nameplate. Minimum permissible gas supply pressure for purpose of input adjustment must be at least 7.0 in. w. c. (inches water column) for natural gas and 11 in. w. c. for LP Gas.

Pipe Delivery Schedule

NOTE: The following procedure and tables apply to Natural Gas only.

1. Obtain from the gas company the heating value and specific gravity of the gas delivered.
2. Determine the exact length of pipe needed.
3. Read BTUH input nameplate on the furnace.
4. Use the multiplier opposite the specific gravity of the gas given in Table 1 below and insert in the following formula:

CFH=	Furnace Input in BTUH
	Gas Heat Conte in BTU/Cu.Ft X Multiplier

5. Using Table 2, select the pipe length nearest to calculated size.
6. Follow this line vertically down to the exact CFH found in Step 4 above or the next highest value.
7. Read horizontally to the left of this column for the required pipe size diameter.

Table 1. Specific Gravity Multiplier

	SPECIFIC GRAVITY	MULTIPLIER
MULTIPLIERS TO BE USED WHEN THE SPECIFIC GRAVITY OF THE GAS IS OTHER THAN 0.60	.50	1.10
	.55	1.04
	.60	1.00
	.65	.962

NOTE: If this is an LP Gas application, consult your LP Gas supplier for pipe sizes and deliveries.

Table 2. Natural Gas Only

TABLE OF CUBIC FEET PER HOUR OF GAS FOR VARIOUS PIPE SIZES AND LENGTHS							
PIPE SIZE (inch)	LENGTH OF PIPE (feet)						
	10	20	30	40	50	60	70
1/2	132	92	73	63	56	50	46
3/4	278	190	152	130	115	105	96
1	520	350	285	245	215	195	180
1-1/4	1050	730	590	520	440	400	370

THIS TABLE IS BASED ON PRESSURE DROP OF 0.3 INCH W.C. AND 0.6 SP.GR. GAS

Gas Pressure Set-up Precautions

IMPORTANT: Do not connect gas piping to the unit until a line pressure test has been completed. This unit should never be exposed to gas line pressure in excess of 14 inches water column (1/2 PSIG). The furnace and its equipment shutoff valve must be disconnected from the gas supply piping system during any pressure testing of that system at test pressures in excess of 1/2 psi.

The furnace must be isolated from the gas supply piping system by closing its individual manual shut-off valve during any pressure testing of the gas supply piping system at test pressures less than or equal to 1/2 psig (3.48 kPa).

Gas Supply Line Pressure

Before connecting the unit to the gas supply line, be sure to determine the gas pressure in the line.

If the gas supply pressure is excessive (above 14 inches water column or 1/2 psig), install a pressure regulator either at the supply source or in the branch circuit serving the unit. Once the regulator is installed, set it to provide a pressure of 7 inches water column with the unit operating and no greater than 14 inches water column with the unit not operating.

NOTE: Gas pressure in excess of 14 inches water column (1/2 psig) may damage the regulator, while improper regulation may result at pressures lower than 5.5 inches water column at the unit inlet.

If the supply line pressure is below the minimum supply pressure indicated on the unit nameplate, contact the gas supply company.

Follow these steps to complete the installation of the unit gas piping. See Figure 17.

NOTE: The shut-off gas cock must be installed outside of the unit and should meet the specifications of all applicable national and local codes.

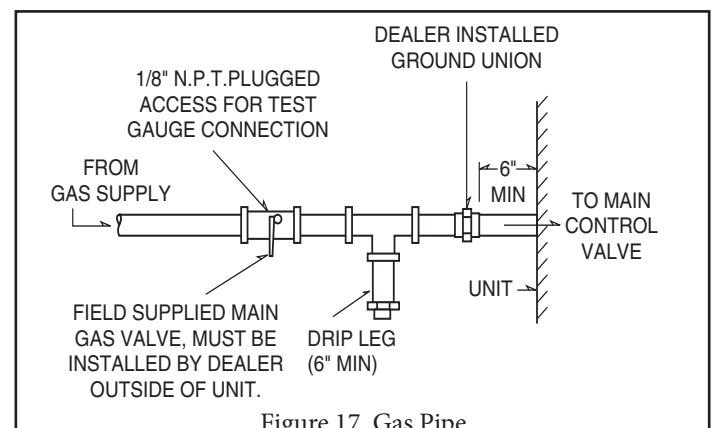

Figure 17. Gas Pipe

1. Install a tapped, Style A (1/8-inch NPT tap) shut-off gas cock at the end of the gas supply line near the unit. Be sure the tapped gas cock is downstream of the pressure regulator, if used.
2. Install a ground union joint downstream of the shut-off cock. This joint must also be installed outside of the unit.
3. Install a drip leg at least six (6) inches in depth next to the union as shown in Figure 17. This drip leg is required to collect any sediment that may be deposited in the line.

Installer's Guide

4. Before connecting the piping circuit to the unit, bleed the air from the supply line and then cap or plug the line and test the pressure at the tapped shut-off cock. The pressure reading should not exceed 14 inches water column.
5. Using an appropriate backup wrench on the gas valve inlet boss, connect the gas piping to the unit. Check the completed piping for leaks using a soap and water solution or the equivalent.
6. After installation of the gas pipe in the unit, the pipe opening should be closed with the filler/barrier plug provided.

- a. Attach a manifold pressure gauge.
- b. Remove the slot screw on top of the gas valve for 1st stage manifold pressure adjustment. Remove slot screw on outlet side for 2nd stage adjustment (See Figure 18).
- c. Turn the adjustment nut in to increase the gas flow rate, and out to decrease the gas flow rate using a 3/32" hex wrench.

Manifold Pressure

Check the manifold pressure at the unit gas valve. Do not exceed the recommended pressure shown on the unit nameplate.

Input Check and Adjustment

1. Make sure all gas appliances are off except the furnace.
2. Clock the gas meter with the furnace operating (determine the dial rating of the meter) for one revolution.
3. Match the "Sec" column in the gas flow (in cfh) Table 3, with the time clocked.
4. Read the "Flow" column opposite the number of seconds clocked.
5. Use the following factors if necessary.

NOTE: For manifold pressures and orifice sizes for gas with

$$\text{For 1 Cu. Ft. Dial Gas Flow CFH} = \frac{\text{Chart Flow Reading}}{2}$$

$$\text{For 1/2 Cu Ft. Dial Gas Flow CFH} = \frac{\text{Chart Flow Reading}}{4}$$

$$\text{For 5 Cu. Ft. Dial Gas Flow CFH} = \frac{10X \text{ Chart Flow Reading}}{4}$$

other BTU ratings, contact the local gas utility. Manifold pressure should be 1.8 (low) to 3.5 (high) inches water column (+0.1). Input for natural gas must not exceed the value shown on the unit nameplate.

6. Multiply the final figure by the heating value of the gas obtained from the utility company and compare to the nameplate rating. This must not exceed the nameplate rating.
7. Changes can be made by adjusting the manifold pressure.

Table 3. Gas Flow in Cubic Feet Per Hour
2 Cubic Foot Dial

Sec.	Flow	Sec.	Flow	Sec.	Flow	Sec.	Flow
8	900	29	248	50	144	82	88
9	800	30	240	51	141	84	86
10	720	31	232	52	138	86	84
11	655	32	225	53	136	88	82
12	600	33	218	54	133	90	80
13	555	34	212	55	131	92	78
14	514	35	206	56	129	94	76
15	480	36	200	57	126	96	75
16	450	37	195	58	124	98	73
17	424	38	189	59	122	100	72
18	400	39	185	60	120	104	69
19	379	40	180	62	116	108	67
20	360	41	176	64	112	112	64
21	343	42	172	66	109	116	62
22	327	43	167	68	106	120	60
23	313	44	164	70	103	124	58
24	300	45	160	72	100	128	56
25	288	46	157	74	97	132	54
26	277	47	153	76	95	136	53
27	267	48	150	78	92	140	51
28	257	49	147	80	90	144	50

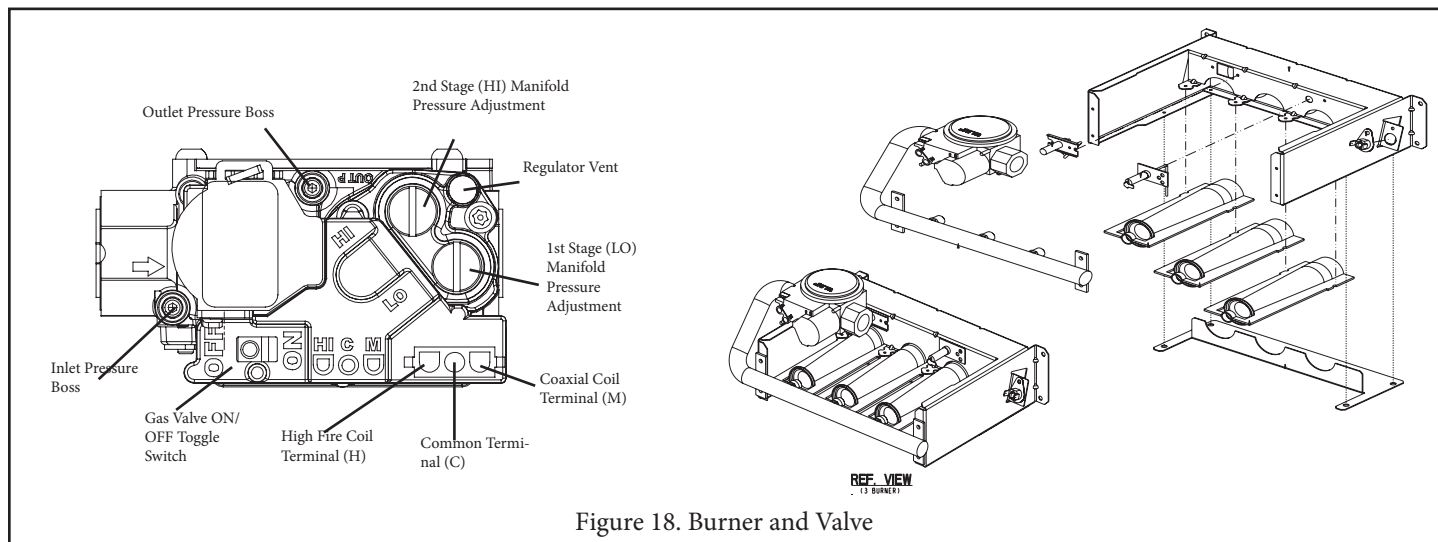

Figure 18. Burner and Valve

High Altitude Installation

Unit nameplate ratings are based on equipment operation from sea level to 2000 feet elevation above sea level. No orifice changes required for high altitude installation, please refer to below chart for rating information.

Table 4. High Altitude Derate Chart

HIGH ALTITUDE DERATE CHART NAT.								
Unit Input	Altitude (In Feet)							
115k	2001	3000	4000	5000	6000	7000	8000	
High stage	112100	104100	96200	88100	86900	85600	85100	
Low stage	84000	78100	72100	66100	65100	64200	63800	
90k								
High stage	87700	81500	75200	69000	68000	67000	66500	
Low stage	65700	61100	56400	51700	51000	50200	49900	
70k								
High stage	68200	63300	58500	53600	52900	52100	51800	
Low stage	51100	47600	43900	40200	39600	39100	38800	
60k								
High stage	58500	54300	50100	46000	45300	44700	44300	
Low stage	43800	40700	37600	34500	34000	33400	33200	

Inputs shown are with factory orifices @ 3.5"WC (High Fire)
 1.8"WC (Low Fire)
 Natural Gas heating value of 950 btu/cuft.
 For LP installations. Models that require #49 orifices, for altitudes from 7000 - 8000' orifices must be changed to #50.

Air Filter Installation

The packaged unit requires an air filter. The unit does not come with a factory installed filter rack in it, however, two filter frame accessories are offered that will allow the installation of a filter within the unit, BAYFLTR101 & BAYFLTR201. Otherwise a field supplied filter rack must be installed by the installer in the return duct work. Refer to Table 5 to determine filter sizes for field supplied filter racks.

Table 5. Filter Sizes (field supplied filter rack)

UNIT	NOMINAL CFM	FILTER SIZE(Sq Ft)	FILTER RESISTANCE ("W.C.)
4DCL4024	800	2.67	0.08
4DCL4030	1000	3.33	0.08
4DCL4036	1200	4	0.08
4DCL4042	1400	4.67	0.08
4DCL4048	1600	5.33	0.08
4DCL4060	2000	6.67	0.08

*Filters must be installed in the return air system. The above square footages are based on 300 F.P.M. face velocity. If permanent filters are used, size per mfg. Recommendation with clear resistance of 0.05" W.C.

IMPORTANT: Air filters and media wheels or plates shall meet the test requirements in UL 900.

Electrical Wiring

⚠ WARNING

HAZARDOUS VOLTAGE, MOVING PARTS, AND GAS

Bodily injury can result from high voltage electrical components, fast moving fans, and combustible gas. For protection from these inherent hazards during installation and service, the electrical supply must be disconnected and the main gas valve must be turned off. If operating checks must be performed with the unit operating, it is the technician's responsibility to recognize these hazards and proceed safely.

NOTE: This unit is factory wired for 230V. See wiring diagram in SERVICE FACTS for 208V conversion.

Electrical Connections

Electrical wiring and grounding must be installed in accordance with local codes or, in the absence of local codes, with the National Electrical Code ANSI/NFPA 70, Latest Revision.

NOTE: For branch circuit wiring (main power supply to unit disconnect), determine wire size for the length of run using the circuit ampacity found on the unit nameplate and the N.E.C.

For more than 3 conductors in a raceway or cable, see the N.E.C. for derating the ampacity of each conductor.

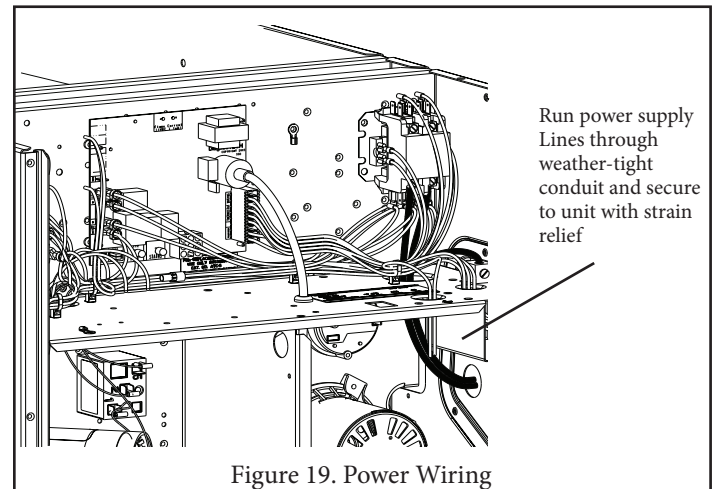

Figure 19. Power Wiring

Electrical Power

It is important that proper electrical power be available for the unit. Voltage variation should remain within the limits found on the unit nameplate.

Disconnect Switch

Provide an approved weatherproof disconnect within close proximity and within sight of the unit. If disconnect must be mounted to the cabinet, the location shown in Figure 21 should be the only one considered.

Over Current Protection

The branch circuit feeding the unit must be protected as shown on the unit nameplate.

Power Wiring

The power supply lines must be run in weather-tight conduit to the disconnect and into the side of the unit control box. Provide strain relief for all conduit with suitable connectors.

Provide flexible conduit supports whenever vibration transmission may cause a noise problem within the building structure.

1. Remove the CONTROL/HEAT access panel. Pass the power wires through the Power Entry hole in the end of the unit. See Figure 19.
2. Connect the high voltage wires to the appropriate contactor lug terminals. Single phase units use a two (2) pole contactor and three phase units use two (2) pole contactor and a Blue lead wire. Connect the ground to the ground lug on the chassis. See Figure 20. Be sure all connections are tight.

GROUNDING: THE UNIT MUST BE ELECTRICALLY GROUNDED IN ACCORDANCE WITH LOCAL CODES OR THE NATIONAL ELECTRIC CODE.

NOTE: Unit must be grounded for ignitor to operate properly. Gas pipe to unit is not an adequate ground. Ground the unit internally as provided.

Installer's Guide

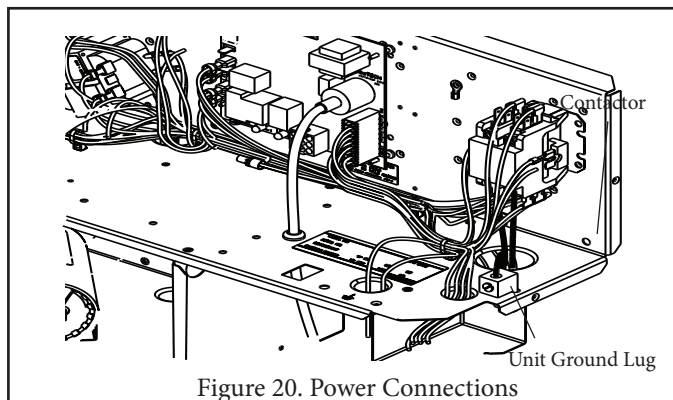

Figure 20. Power Connections

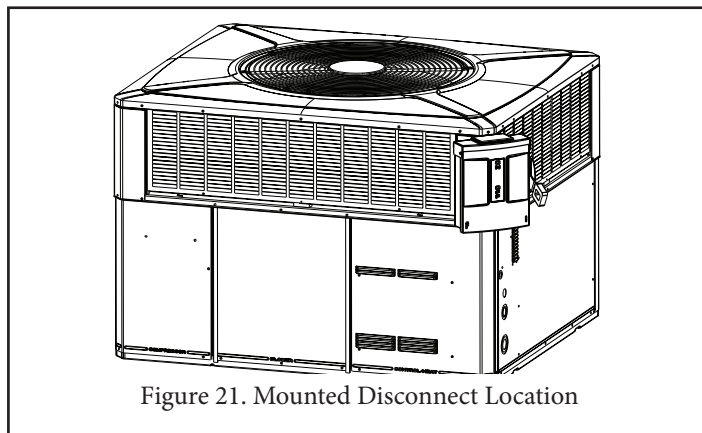

Figure 21. Mounted Disconnect Location

Control Wiring (Class II)

Low voltage control wiring should not be run in conduit with power wiring unless Class 1 wire of proper voltage rating is used. Route the thermostat cable or equivalent single leads of No. 18 AWG colored wire from the thermostat subbase terminals through the rubber grommet on the unit. See Figures 2 or 5 for the control entry (24V Entry) location. Make connections as shown on the unit wiring diagram.

Do not short thermostat wires since this will damage the control transformer.

Refer to Table 6 for recommended wire sizes and lengths for installing the unit thermostat. The total resistance of these low voltage wires must not exceed one (1) ohm. Any resistance in excess of 1 ohm may cause the control to malfunction because of the excessive voltage drop.

Table 6. Thermostat Wire Size and Maximum Length

Wire Size	Maximum Length
18	75
16	125
14	200

Thermostat Operation

Operation of the unit heating or cooling cycles is controlled by the comfort control. Once the system mode is set to either HEAT or COOL, unit operation is automatic. The fan ON setting provides continuous indoor blower operation at constant circulation - approximately 40 - 50% of nominal airflow at selected dipswitch settings. The AUTO setting provides indoor blower operation during the compressor heating and cooling cycles. CONTINUOUS fan mode during COOLING operation may not be appropriate in humid climates. If the indoor air exceeds 60% relative humidity or simply feels uncomfortably humid, it is recommended that the fan only be used in the AUTO mode.

NOTE: The 4DCL units require approved dual fuel comfort control. Do not install any other model of thermostat with this 4DCL unit. Otherwise, mis-operation could result.

NOTE: See Comfort Control Guide for required sensors & jumper add or removals.

NOTE: The 4DCL units are equipped with an outdoor temperature switch to limit gas operation. For outdoor temperatures above 40 degrees, heating is provided by Heat Pump operation only. For temperatures 40 and below, heating may be provided by both gas or Heat Pump operation.

TWO MODES OF OPERATION:

The unit can be installed and configured to operate in one of two different heating modes: restricted and non-restricted. A brief explanation of each mode follows.

RESTRICTED: In the restricted mode of operation, an outdoor temperature sensor is used to cause the unit to operate in the heat pump mode above a selected outdoor temperature and to operate in the gas heating mode below the selected outdoor temperature.

NOTE: The 4DCL units are equipped with an outdoor temperature switch to limit gas operation. For outdoor temperatures above 40 degrees, heating is provided by Heat Pump operation only.

The gas heat will operate with the heat pump when the unit requires a defrost cycle. The gas heat is used to offset the effect of the unit going into the cooling mode during defrost. For the *CONT402, the unit will be commanded to transition to gas heat even when the outdoor temperature is above the selected outdoor temperature changeover point if the heat pump capacity is not enough to maintain the indoor temperature at the desired heating setpoint.

NON-RESTRICTED: This mode of operation only allows the unit to operate in the heat pump mode during the first call, or stage of heat commanded by the indoor thermostat. If the heat pump capacity is sufficient, gas heat will not be required. If the heat pump capacity is not enough to maintain the indoor temperature at the desired heating setpoint, the thermostat will call for the second stage of heat. At that point, the gas heat will begin to operate and the heat pump will be locked out.

NOTE: The 4DCL units are equipped with an outdoor temperature switch to limit gas operation. For outdoor temperatures above 40 degrees, heating is provided by Heat Pump operation only.

See the Field Wiring Diagram, page 21, for field wiring instructions.

IMPORTANT: Upon completion of wiring, check all electrical connections, including factory wiring within the unit. Make sure all connections are tight. Replace and secure all electrical box covers and access doors before leaving the unit or turning on the power to the unit.

NOTE: The outdoor sensor should be located in an area which will provide a representative outdoor ambient temperature reading.

4DCL4 FIELD WIRING DIAGRAM

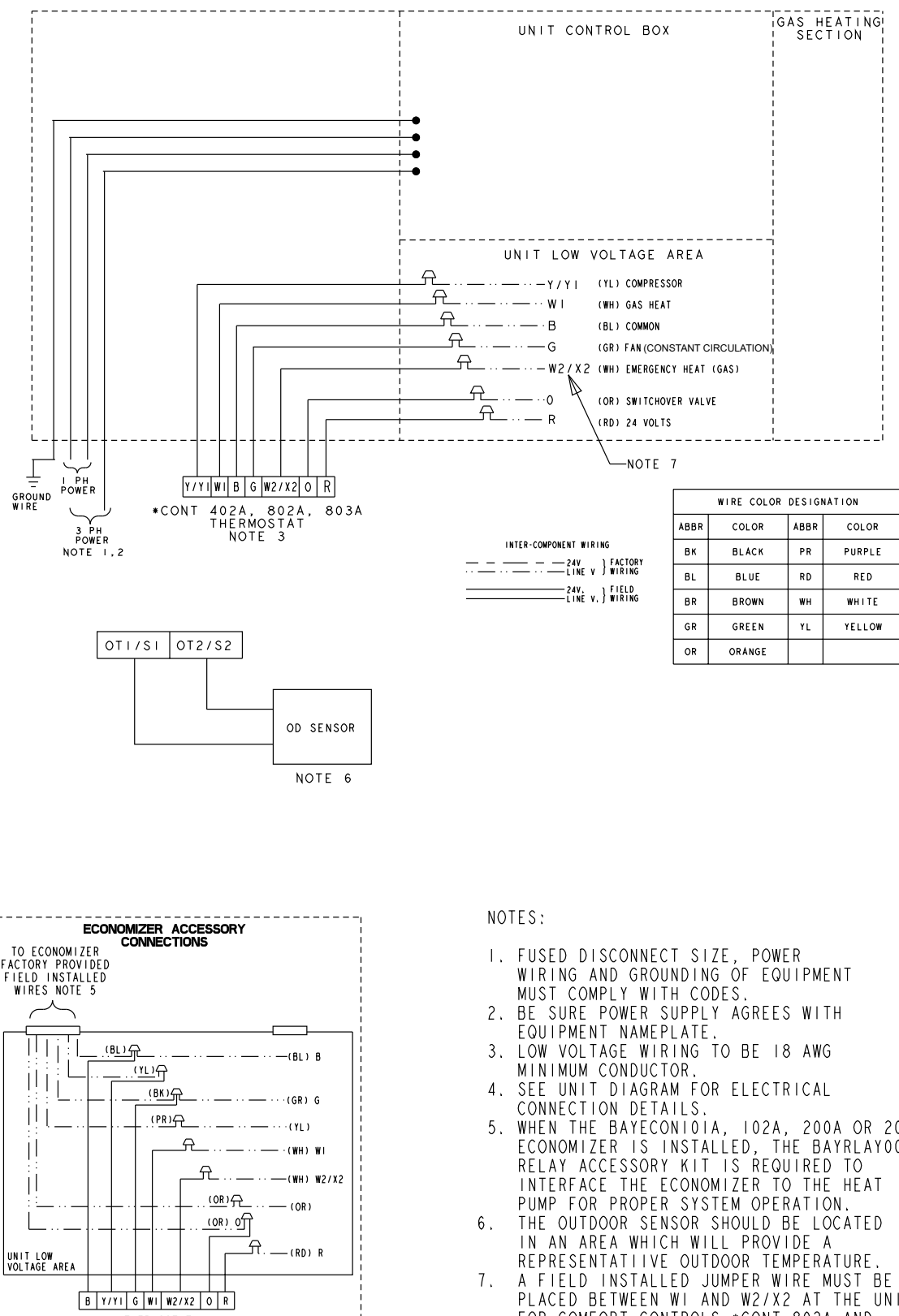

Figure 22. 4DCL4 Field Wiring Diagram

Step 5—Unit Startup

Pre-Start Quick Checklist

- Is the unit properly located and level with the proper clearance? See Figures 1-6, pages 4-9.
- Is the duct work correctly sized, run, taped, insulated, and weatherproofed with proper unit arrangement? See Ductwork Installation section on page 16.
- Is the gas piping correctly sized, run, trapped, and purged of air? See Gas Piping section on page 17.
- Is the condensate line properly sized, run, trapped, and pitched? See Condensate drain section on page 16.
- Is the filter of the correct size and number? Is it clean and in place? See Air Filter section on page 19.
- Is the wiring properly sized and run according to the unit wiring diagram?
- Are all the wiring connections, including those in the unit, tight?
- Has the unit been properly grounded and fused with the recommended fuse size?
- Is the thermostat correctly wired and well located?
- Is the W1 to W2 jumper installed at the unit when using a *CONT802 or *CONT803 Comfort Control?
- Have the air conditioning systems been checked at the service ports for charge and leak tested if necessary?
- Does the condenser fan and indoor blower turn free without rubbing, and are they tight on the shafts?
- Has the indoor blower speed been determined and the proper speed been set?
- Has all work been done in accordance with applicable local and national codes?
- Are all covers and access panels in place to prevent air loss and safety hazards?

Starting the Unit in the Cooling Mode

NOTE: See the section on “Sequence of Operation”, page 24, for a description of the cooling operating sequence.

To start the unit in the cooling mode, set the comfort control to COOL and adjust the cooling setpoint below the room temperature. Wait for the minimum compressor off time to elapse. The condenser (outdoor) fan motor, compressor, and evaporator (indoor) fan motor will operate automatically.

Operating Pressures

After the unit has operated in the cooling mode for a short period of time, install pressure gauges on the gauge ports of the discharge and suction line valves. Check the suction and discharge pressures and compare them to the normal operating pressures provided in the unit's SERVICE FACTS.

NOTE: Do not use the PRESSURE CURVES from the unit's SERVICE FACTS to determine the unit refrigerant charge. The correct charge is shown on the unit nameplate. To charge the system accurately, weigh in the charge according to the unit nameplate and check subcooling against the Subcooling Charging Table in the SERVICE FACTS.

Voltage

With the compressor operating, check the line voltage at the unit. The voltage should be within the range shown on the unit nameplate. If low voltage is encountered, check the size and length of the supply line from the main disconnect to the unit. The line may be undersized for the length of the run.

Cooling Shut Down

Set the comfort control to OFF or adjust the cooling setpoint above the room temperature.

Starting the Unit in the Heat Pump Heating Mode

NOTE: See the section on “Sequence of Operation”, page 23, for a description of the heat pump heating operating sequence.

Check to make sure all grilles and registers are open and all unit access doors are closed before start-up.

The comfort control may be temporarily operated in Manual Test Mode for the *CONT402 or in Installer System Test mode for the *CONT802 AND *CONT803. These are modes designed to be used to “bump” the system on the various capacity stages. Since the test mode timeouts are 1 minute and 5 minutes respectively (in the absence of installer key presses), these modes are not designed to be used as the only means of system checkout. Normal thermostat operation should be used for operating the unit for extended periods of time.

To start the unit in the heat pump heating mode, set the comfort control to HEAT and adjust the heating setpoint slightly above the room temperature. Wait for the minimum compressor off time to elapse. The condenser (outdoor) fan motor, compressor, and evaporator (indoor) fan motor will operate automatically.

Heat Pump Heating Shut Down

Set the comfort control to OFF or adjust the heating setpoint below the room temperature.

Gas Furnace Heating Cycle

In addition to the heat pump controls, these units are equipped with a solid-state ignition control that lights the burners each time the thermostat calls for heat. The burners are extinguished during the OFF cycle.

NOTE: See the section on "Sequence of Operation", page 24, for a description of the heating operating sequence.

The gas heating section of the unit can be started using the following procedure:

1. Be sure the comfort control is configured to power up in the OFF mode, or be prepared to change the comfort control to OFF just as soon as power is applied to the thermostat in the steps below.
 - a. Turn the main shutoff valve on the gas supply line ON.
 - b. Turn or switch the manual valve on the combination gas valve to the ON position.
2. Be sure the burner compartment access panel is in place.
 - a. Turn on the electrical power to the unit.
 - b. Change the thermostat mode to Emergency Heat and adjust the heating setpoint slightly above the room temperature.
3. When the comfort control calls for heat, the system operates as follows:
 - a. The combustion blower is energized.
 - b. The pressure switch is closed.
 - c. The gas valve opens and the ignitor lights the burner.
 - d. Allow the comfort control to cycle on and off a few times in Emergency Heat mode to check out the control system and burner operation characteristics. For the *CONT802 and *CONT803 Comfort Controls if the call for heat lasts longer than 10 minutes, these controls will transition to high fire automatically.
4. With the burners operating, check the manifold pressure with a manometer. Do not exceed recommended pressures.
5. Adjust the unit to obtain an air temperature rise with that specified on the unit nameplate.

NOTE: For manifold pressures and orifice sizes for gas with other BTU ratings, contact the local gas utility. Manifold pressure should be 1.8 (low) to 3.5 (high) inches water column (+0.1). Input must **not** exceed the value shown on the nameplate.

6. Set the comfort control the desired temperature setting and the unit will function automatically.

Starting the Unit in Gas Heating Mode

1. Check to make sure all grilles and registers are open and all unit access doors are closed before start-up.
2. Purge the gas supply line of air by opening the union ahead of the unit. When the odor of gas is detected, retighten the union and wait five (5) minutes before proceeding.
3. Open the main gas valve(s) and turn on the unit power supply.
4. Set the comfort control to Emergency Heat and adjust the heating setpoint slightly above the room temperature.
5. The combustion blower motor should energize. The main burners should light within 20-25 seconds. Initial start may be delayed somewhat if the unit has not been purged and air is trapped in the gas line.

NOTE: Blue smoke produced by the heat exchanger during the initial burner firing is caused by a thin film of oil on the surface of the heat exchanger. This oil will burn off quickly.

6. Allow the comfort control to cycle on and off a few times at a rate of not more than once every thirty (30) seconds. Check both the control operation and the burner operating conditions.
7. Increase the heating setpoint significantly so that the comfort control will transition to high fire automatically. For the *CONT802 and *CONT803 Comfort Controls, there is a 10 minute delay before the transition occurs. Make the following manifold pressure check on high fire.

Manifold Pressure

1. Connect a manometer to the pressure boss at the outlet side of the unit's gas valve. Read the manifold pressure with the main burners firing. See figure 18, page 18.
2. If the manifold pressure reading does not match the value indicated on the unit nameplate, the unit pressure regulator must be adjusted as follows:
 - a. Remove the cover screw on the gas regulator located on the front side of the unit's gas valve.
 - b. Turn the adjusting screw clockwise to increase manifold pressure or counterclockwise to decrease manifold pressure.
3. Check the temperature rise during furnace operation to insure that it falls within the range specified on the unit nameplate.
4. If the temperature rise noted is outside of the specified limits, adjust the indoor airflow to cause the temperature rise of the heat exchanger to fall within the required range.

Heating Shut Down

Set the comfort control to OFF or adjust the heating set point to below room temperature.

Final Installation Checklist

- Does the unit run and operate as described in the section on Sequence of Operation, page 24, in response to the room thermostat?
- Are the condenser fan and indoor blower operating correctly with proper rotation and without undue noise?
- Is the compressor operating correctly and has the system been checked with a charging chart?
- Has the voltage and running current been checked to determine if it is within limits?
- Has the thermostat been checked for calibration and the air discharge grilles adjusted to balance the system?
- Has the ductwork been checked for air leaks and condensation?
- Has the furnace manifold pressure been checked and adjusted if necessary?
- Has the heating air temperature rise been checked?
- Has the unit been checked for tubing and sheet metal rattles? Are there any other unusual noises to be checked?
- Are all covers and panels in place and properly fastened?
- Has the owner been instructed on the proper operation and maintenance of the unit? Be sure to leave this manual with the owner.

Installer's Guide

Sequence of Operation

Operation of the unit heating or cooling cycles is controlled by the mode setting of the room thermostat. Once the system mode is set to either HEAT or COOL, unit operation is automatic. The thermostat fan ON setting provides continuous indoor blower operation at constant circulation airflow of 40-50% nominal of selected settings while the AUTO setting provides indoor blower operation during the compressor heating and cooling cycles. Continuous fan mode during cooling operation may not be appropriate in humid climates. If the indoor air exceeds 60% relative humidity or simply feels uncomfortably humid, it is recommended that the fan only be used in the AUTO mode.

NOTE: The 4DCL units require approved dual fuel comfort control. Do not install any other model of thermostat with this 4DCL unit. Otherwise, mis-operation could result.

NOTE: See Comfort Control Guide for required sensors & jumper add or removals.

NOTE: The 4DCL units are equipped with an outdoor temperature switch to limit gas operation. For outdoor temperatures above 40 degrees, heating is provided by Heat Pump operation only. For temperatures 40 and below, heating may be provided by both gas or Heat Pump operation.

TWO MODES OF OPERATION:

The unit can be installed and configured to operate in one of two different heating modes: restricted and non-restricted. A brief explanation of each mode follows.

RESTRICTED: In the restricted mode of operation an outdoor temperature sensor is used to cause the unit to operate in the heat pump mode above a selected outdoor temperature and to operate in the gas heating mode below the selected outdoor temperature.

NOTE: 4DCL units are equipped with an outdoor temperature switch to limit gas operation. For outdoor temperatures above 40 degrees, heating is provided by Heat Pump operation only.

The gas heat will operate with the heat pump when the unit requires a defrost cycle. The gas heat is used to offset the effect of the unit going into the cooling mode during defrost. For the *CONT402, the unit will be commanded to transition to gas heat even when the outdoor temperature is above the selected outdoor temperature changeover point if the heat pump capacity is not enough to maintain the indoor temperature at the desired heating setpoint.

NON-RESTRICTED: This mode of operation allows the unit to operate in the heat pump mode during the first call, or stage, of heat commanded by the indoor thermostat. If the heat pump capacity is sufficient, gas heat will not be required. If the heat pump capacity is not enough to maintain the indoor temperature at the desired heating setpoint, the thermostat will call for the second stage of heat. At that point, the gas heat will begin to operate and the heat pump will be locked out.

NOTE: 4DCL units are equipped with an outdoor temperature switch to limit gas operation. For outdoor temperatures above 40 degrees, heating is provided by Heat Pump operation only.

As in restricted mode, the gas heat will act as supplementary heat during the unit's defrost cycle. See the Field Wiring Diagram in the Installer's Guide for field wiring instructions.

IMPORTANT: Upon completion of wiring, check all electrical connections, including factory wiring within the unit. Make sure all connections are tight. Replace and secure all electrical box covers and access doors before leaving the unit or turning on the power to the unit.

NOTE: The outdoor sensor should be located in an area which will provide a representative outdoor ambient temperature reading.

The following description applies to the *CONT402. Some of the operational differences of the *CONT802 and *CONT803 are described at the end of this section.

The following description applies to non-restricted mode. Restricted operation will be identical except that transitions from and to first stage (heat pump) heating to and from second stage (gas) heating can occur, not necessarily as a result of building load and equipment capacity, but as determined by the outdoor temperature changeover point selected by the installer at the indoor thermostat (see Restricted Mode description).

Call for 1st stage heating (heat pump):

With the disconnect switch in the ON position, current is supplied to the compressor crankcase heater, if supplied with one, and to the control transformer. When the thermostat calls for first stage heat, power from (R) is switched by the thermostat to the (Y/Y1) terminal. This powers the compressor contactor (CC) which starts the outdoor fan motor and compressor. The thermostat also switches (R) power to (G) thereby starting the indoor blower motor (IDM).

To maintain the indoor temperature at the desired setpoint, the thermostat may operate the heat pump continuously or cycle the heat pump off and on (cycling on 1st stage heat).

Cycling on 1st stage heat: When the thermostat cycles the heat pump off, power is removed from (Y/Y1) and (G). If the indoor blower delay is defeated in the unit, it is an installer option for the thermostat to control the delay of the indoor blower by using (G). If there is a thermostat controlled indoor blower delay, the thermostat will turn (G) off after the delay time set within the thermostat has elapsed.

Call for 2nd stage heating (gas) after 1st stage (heat pump): If the heat pump capacity is not enough to handle the building load, the heat pump is turned off and the gas heat is brought on as the second stage of heat. The thermostat will call for second stage heat by removing power from (Y/Y1) and by powering (W1). (G) will remain energized for a minimum of 2 minutes so that the transition to gas heat will not interrupt indoor airflow.

(W1) from the thermostat signals the control module (IGN) to run its self-check routine. After the control module has verified that the pressure switch (PS) contacts are open, the limit switch (TCO) contacts are closed, and the flame rollout (RO) switch is closed, the induced draft blower (CFM) will be energized on high speed for approximately 5 seconds.

After the induced draft blower (CFM) has come up to speed, the control will verify that the pressure switch (PS) contacts are closed and will switch the induced draft blower to low speed for a 20 second prepurge. The gas valve (GV) is energized in the first stage to permit gas flow and the spark igniter (IP) is energized. The flame detector (FD) confirms that ignition has been achieved within the 7 second trial period.

When the flame detector confirms that ignition has been achieved, the delay to indoor blower ON period begins timing. After approximately 45 seconds, the control module (IGN) will take over control of the indoor blower motor (IDM). The control module (IGN) will command the indoor blower to operate at low speed throughout the heating cycle.

To maintain the indoor temperature at the desired setpoint, the thermostat may operate the low fire gas heating continuously or cycle low fire gas heating off and on (cycling on 2nd stage heat).

Note: The 4DCL units are equipped with an outdoor temperature switch to limit gas operation. For outdoor temperatures above 40degrees, the outdoor temperature switch and relays will substitute the W1 signal from the thermostat and provide a Y/Y1 signal. The unit will then operate in 1st stage heat (heat pump).

Cycling on 2nd stage heat: When the thermostat cycles off during second stage heating, power will be removed from (W1), the gas valve (GV) will close, and the flame will extinguish. The induced draft blower (CFM) will continue to run for a postpurge period of approximately 5 seconds before shutting off. The indoor blower motor (IDM) will continue to operate as the heat exchanger cools down (the delay is field selectable for 45 or 90 seconds) before being turned off by the control module.

NOTE: During gas heating operation, the indoor blower is controlled by the normal sequence of gas furnace operation, and not by the thermostat.

*Note that the *CONT402 may transition from second stage heating (gas) to first stage (heat pump) and then back to second stage heating (gas) instead of just cycling the gas heat on and off if the building load is relatively low (see the Transitioning from 2nd stage heating (gas) to 1st stage (heat pump) section for a complete description).*

Call for 3rd stage heating (gas) after 2nd stage (gas):

The thermostat adds (W2/X2) to (W1) signaling a call for second stage heat. The induced draft motor (CFM) is energized on high speed and the gas valve (GV) on second stage. After approximately 30 seconds the control energizes the indoor blower on high speed.

Cycling on 3rd stage heat: When the thermostat cycles on third stage heating, power will be removed from (W2/X2) and (W1) will remain powered. The control module (IGN) will switch the gas valve (GV) to first stage and the induced draft blower (CFM) to low speed. After approximately 30 seconds the indoor blower motor is reduced to low speed.

NOTE: The 4DCL units are equipped with an outdoor temperature switch to limit gas operation. For outdoor temperatures above 40 degrees, the outdoor temperature switch and relays will substitute the W1 signal from the thermostat and provide a Y/Y1 signal. The unit will then operate in 1st stage heat (heat pump).

NOTE: During gas heating operation, the indoor blower is controlled by the normal sequence of gas furnace operation, and not by the thermostat.

Transitioning from 3rd stage heating (gas) to 2nd stage (gas):

Same sequence as cycling on 3rd stage heat (described previously) except that the thermostat will make the transition as described previously but will then begin to operate continuously on second stage heating or will begin cycling on second stage heating.

Transitioning from 2nd stage heating (gas) to 1st stage (heat pump):

When the thermostat is cycling on second stage heat, the load may decrease to the point where the thermostat determines that the heat pump would have sufficient capacity to maintain the indoor temperature at the desired setpoint. When this occurs, power will be removed from (W1). This will cause the gas valve (GV) to close and the control module to de-energize the induced draft blower (CFM) after approximately 5 seconds postpurge. The indoor blower motor (IDM) will continue to operate (with no (G) signal) for the blower off period (45 or 90 seconds) while the heat exchanger cools down. At approximately 45 seconds after power was removed from (W1), the thermostat will apply power to (Y1). This powers the compressor contactor (CC) which starts the outdoor fan motor and compressor. The thermostat will also apply power to (G) at this time so that the transition from gas heat to heat pump will not interrupt indoor airflow. The purpose of the 45 second delay is to give the indoor coil sufficient time to cool down before resuming compressor operation.

Installer's Guide

Turning off from 1st stage:

Same sequence as cycling on 1st stage heat (described previously) except that the thermostat will make the transition to off as described previously and will keep the heat pump turned off.

Cooling Cycle:

With the comfort control set to COOL and the fan set to AUTO, the thermostat will energize (Y/Y1), (G), and (O). These signals will energize the compressor contactor (CC), the indoor blower motor (IDM), and the switchover valve (SOV), respectively.

The energized compressor contactor (CC) completes the circuit to the compressor (CPR) and a secondary circuit to the outdoor fan motor (ODM). If the compressor safety controls are closed, the compressor (CPR) will operate with the outdoor fan motor (ODM). The indoor blower motor (IDM) will operate as a result of the (G) signal. The thermostat will continue to cycle the compressor with the indoor blower to maintain the indoor temperature at the desired setpoint. With the thermostat fan switch in the ON position, the indoor blower motor (IDM) will continue to run at constant circulation regardless of compressor and condenser fan operation.

*CONT802 and *CONT803 Operational Differences from the above sequence:

NOTE: Unlike the *CONT402, these two controls will not call for the furnace to operate when the outdoor temperature is above the selected outdoor temperature changeover point even if the heat pump capacity is not enough to maintain the indoor temperature at the desired heating setpoint. If it is anticipated that the installer selected outdoor temperature changeover point from heat pump to furnace must be set to a temperature at or below where this occurs, then the *CONT402 control must be used instead of the *CONT802 and *CONT803 Comfort Controls.

These two controls are not able to cycle on second stage heat in the same way as the *CONT402. The *CONT402 can cycle the gas heat on and off to maintain the indoor temperature at the desired heating setpoint without transitioning to heat pump operation each cycle if the building load is relatively high. These two controls will cycle on second stage heat by alternating between gas heat and heat pump operation. These two controls may take up to 25 minutes to transition between heat pump and gas operation.

These two controls require a field installed jumper wire between the W1 and W2/X2 low voltage wires at the 4DCL unit since these two controls produce only a W1 output for auxiliary heat. This jumper will result in low fire gas heating for 10 minutes or for as long as W1 is present if less than 10 minutes during auxiliary heating. Then, if the W1 signal is still present from the Comfort Control, the 4DCL unit will transition automatically to high fire and operate on high fire for the remaining duration of the call for auxiliary heat. During Emergency Heat mode operation these two controls will first energize X2 on a call for heat and will potentially energize W1 as well. In contrast, the *CONT402 Comfort Control will first energize W1 on a call for Auxiliary or Emergency Heat mode and will potentially energize W2 as well as required by the building load.

DEMAND DEFROST OPERATION

During the heating cycle, the outdoor coil may require a defrost cycle which is determined by the demand defrost control (DFC). This control continuously measures the outdoor coil temperature (CBS) and the outdoor ambient temperature (ODS-B) and calculates the difference or delta-T measurement. An initiate delta-T is calculated based on the delta-T measurements obtained after defrost terminates (when the outdoor coil should be clear of frost). When the measured delta-T during heating operation reaches the calculated initiate delta-T, the demand defrost control (DFC) opens the circuit to the outdoor fan motor (ODM) and energizes the switch-over valve (SOV), placing the unit in the cooling mode to defrost the outdoor coil. The outdoor coil temperature sensor (CBS) terminates the defrost cycle, or times off after twelve, fifteen, or twenty minutes in defrost, the (DFC) energizes the outdoor fan motor (ODM) and fifteen seconds later de-energizes the (SOV), which returns the unit to the heating mode. Supplementary gas heat is brought on to control indoor temperature during the defrost cycle.

Safety Sequences

This product is equipped with the following devices.

The temperature limit switch (TCO) is located on the blower barrier, and can be accessed through the blower compartment. This automatic reset device protects against excessive supply air temperature. If this device opens, the gas valve is immediately closed and will not permit operation until the limit switch closes.

The rollout switch (RO) is located in the gas compartment near the inlet of the burners. This is a manual reset device designed to protect against any form of flame rollout. If this device is opened the gas valve is immediately de-energized and the control (IGN) will lockout the system. The rollout switch (RO) must be reset before operation is allowed to continue.

The pressure switch (PS) is located in the upper right side of the gas compartment. This automatic device assures adequate combustion air pressure. If pressure against the induced draft blower outlet becomes excessive, the pressure switch will react and shut off the gas valve, until acceptable combustion pressure is again available.

If the control (IGN) does not sense flame within the first trial for ignition period, the gas valve will be de-energized. The control (IGN) will initiate a 60-second interpurge. Following the interpurge, the control will perform a second ignition attempt. If the second try is not successful, the control will start another 60-second interpurge. After the interpurge a third attempt will be tried. If the third try is not successful, the control will lock out.

If loss of flame occurs during a heating cycle, the control (IGN) will close the gas valve and cycle through the ignition trial as stated above.

If control lock out occurs, the control (IGN) will retry a complete ignition sequence in 1 hour.

The control (IGN) can be reset by removing power to the unit or by turning the thermostat from ON to OFF for approximately three seconds, then back ON.

Maintenance

Owner Maintenance

WARNING

EXPLOSION HAZARD!

To prevent an explosion or possible injury, death, and equipment damage. Do not store combustible materials, gasoline, or other flammable vapors or liquids near the unit.

Some of the periodic maintenance functions of the packaged unit can be performed by the owner; this includes replacing the disposable or cleaning the permanent air filters, cleaning the unit cabinet, and conducting a general unit inspection on a regular basis.

Filters

When the system is in constant operation, inspect the filters at least once each month.

If you have disposable-type filters, replace them with new filters of the same type and size. Do not attempt to clean disposable filters.

Permanent-type filters can be cleaned by washing them with a mild detergent and water. Make sure that the filters are thoroughly dry before reinstalling them.

NOTE: *It may be necessary to replace permanent filters annually if washing fails to clean the filter or if the filter shows signs of deterioration. Be sure to use the same type and size as was originally installed.*

Condenser Coil

Be sure to keep all vegetation and debris away from the condenser coil area.

Service Maintenance

Service maintenance should be performed by qualified service personnel.

Cooling Season

To keep the unit operating safely and efficiently, the manufacturer recommends that a qualified service technician check the entire system at least once each year or more often if needed. The service technician should examine these areas of the packaged unit:

- ☒ filters (for cleaning or replacement)
- ☒ motors and drive system components
- ☒ economizer gaskets (for possible replacement)
- ☒ safety controls (for mechanical cleaning)
- ☒ electrical components and wiring (for possible replacement and connection tightness)
- ☒ condensate drain (for proper sealing and cleaning)
- ☒ unit duct connections (to see that they are physically sound and sealed to the unit casing)
- ☒ unit mounting support (for structural integrity)
- ☒ the unit (for obvious unit deterioration)

Heating Season

Complete the following unit inspections and service routines described at the beginning of each heating season.

- ☒ Visually inspect the unit to ensure that the airflow required for combustion and condenser coil is not obstructed from the unit.
- ☒ Inspect the control panel wiring to verify that all electrical connections are tight and that the wire insulation is intact.
- ☒ Check the operation of the gas ignition system as follows: Turn off the gas supply with the unit operating to verify that the gas valve closes and that a re-ignition cycle is initiated by the unit.
- ☒ Visually inspect the inside of the burners and the burner ports for deposit buildup and corrosion. Wipe and brush the inside of the burner and the burner ports and then clean with a dry cloth. If the deposit buildup or corrosion is excessive, replace the burners.

Flue Hood and Combustion Blower Cleaning

CAUTION

Never use combustible cleaning fluids on any part of the furnace.

Before each heating season, the flue should be inspected for signs of flaking rust and soot deposits. Dirty flues should be cleaned by qualified service personnel ONLY using the following procedure:

1. Turn the comfort control to OFF. Turn the main power disconnect OFF. Turn the manual gas valve OFF.
2. Remove the flue hood and the CONTROL/HEAT access panel.
3. Remove the combustion blower assembly from the flue box. Remove the flue box and the flue restrictors.
4. Remove all wires from the gas valve while carefully noting their locations.
5. Disconnect the gas supply line from the valve.
6. Remove the manifold retaining screws and pull the burner-manifold assembly from the heat exchanger.
7. Remove the inlet turbulators being careful not to break or damage them.
8. Wipe the flue box and flue baffles clean with a clean, dry cloth.
9. Replace all gaskets with new ones.
10. Replace all damaged or broken turbulators with new ones.
11. Reassemble the unit by reversing Steps 2 through 7 above. Take care that all gaskets seat properly.
12. Check all wires for correct installation by referring to the unit electrical wiring diagram in the SERVICE FACTS.
13. Leak test all gas line connections with a soap and water solution or the equivalent.
14. Re-install the CONTROL/HEAT access panels and the flue hood.
15. Visually inspect the unit to ensure that the airflow opening for combustion is not obstructed.
16. Follow the start-up procedure on page 22 to place the unit back in service.

Installer's Guide

ECM Fan Motor Adjustments

If the airflow needs to be increased or decreased, see the Airflow Table in the SERVICE FACTS. Information on changing the speed of the blower motor is in the Blower Performance Table. Blower speed changes are made on the ECM Fan Control mounted in the control box. The ECM Fan Control controls the variable speed motor. There is a bank of 8 dip switches, (See Figure 23 below) located on the board. The dip switches work in pairs to match the cooling/heat airflow (CFM/TON), Fan off-delay options and electric heat airflow adjustment. The switches appear as shown in the figure below.

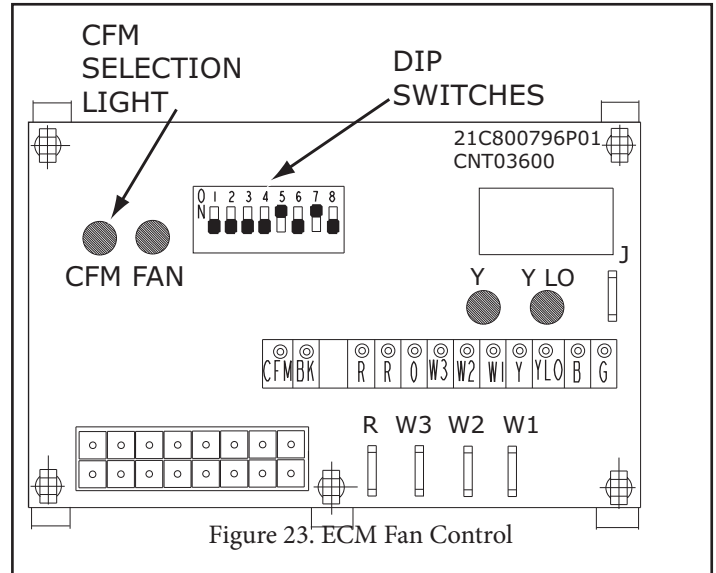

Figure 23. ECM Fan Control

Status LEDs

IGN Board Diagnostic Codes

There are two LEDs on the IGN board that provide status and diagnostic information. Refer to Table 7 for a description of the LED codes.

Table 7. IGN LED Diagnostic Indicators

IGN Diagnostic Indicators Flash Codes			
Status LED		Liteport LED	
Steady OFF	Check Power or Failed Board	2 Flashes	System Lockout: Failed to detect or sustain flame
Slow Flash Rate	Normal, No Call for Heat	3 Flashes	Pressure switch problem detected
Fast Flash Rate	Not used	4 Flashes	High Limit switch protection device open
Steady ON	Normal, No Call for Heat	5 Flashes	Flame sensed and gas valve <u>not</u> energized or flame sensed and no "W" signal
		6 Flashes	Flame Rollout Switch open
		7 Flashes	Thermostat miswired; W1 & W2
<p>Fast Flash Rate: The LED will flash on for 1/4 second, and off for 1/4 second</p> <p>Slow Flash Rate: The LED will flash on for 3/4 second, then off for 1/4 second.</p> <p>The pause between groups of fast flashes is 3 seconds.</p>			



Trane
6200 Troup Highway
Tyler, TX 75707