

Installer's Guide

Single Packaged Gas/Electric 14 SEER Convertible, 2 – 5 Ton

4YCC4024A1060A
4YCC4030A1070A
4YCC4036A1070A
4YCC4036A1090A
4YCC4042A1060A
4YCC4042A1090A
4YCC4048A1070A
4YCC4048A1090A
4YCC4060A1090A
4YCC4060A1115A

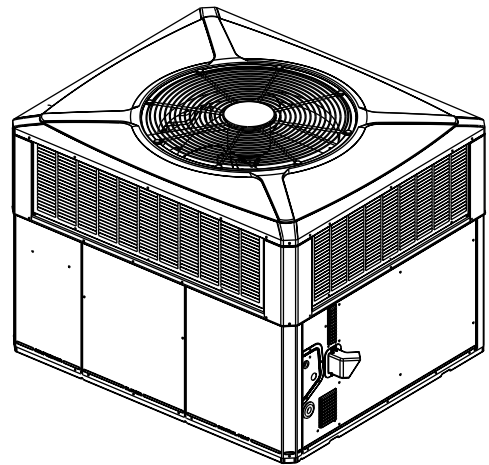

▲ SAFETY WARNING

Only qualified personnel should install and service the equipment. The installation, starting up, and servicing of heating, ventilating, and air-conditioning equipment can be hazardous and requires specific knowledge and training. Improperly installed, adjusted or altered equipment by an unqualified person could result in death or serious injury. When working on the equipment, observe all precautions in the literature and on the tags, stickers, and labels that are attached to the equipment.

SAFETY SECTION

Important — This document contains a wiring diagram, a parts list, and service information. This is customer property and is to remain with this unit. Please return to service information pack upon completion of work.

⚠ WARNING

HAZARDOUS GASES!

Exposure to fuel substances or by-products of incomplete fuel combustion is believed by the state of California to cause cancer, birth defects, or other reproductive harm.

This warning complies with state of California law, Proposition 65.

⚠ WARNING

HAZARDOUS VOLTAGE!

Failure to follow this Warning could result in property damage, severe personal injury, or death.

Disconnect all electric power, including remote disconnects before servicing. Follow proper lockout/tagout procedures to ensure the power cannot be inadvertently energized.

⚠ WARNING

SAFETY AND ELECTRICAL HAZARD!

Failure to follow this Warning could result in property damage, severe personal injury, or death.

These servicing instructions are for use by qualified personnel only. To reduce the risk of electrical shock, do not perform any servicing other than that contained in these operating instructions unless you are qualified to do so.

⚠ CAUTION

GROUNDING REQUIRED!

Failure to inspect or use proper service tools may result in equipment damage or personal injury. Reconnect all grounding devices. All parts of this product that are capable of conducting electrical current are grounded. If grounding wires, screws, straps, clips, nuts, or washers used to complete a path to ground are removed for service, they must be returned to their original position and properly fastened.

⚠ WARNING

UNIT CONTAINS R-410A REFRIGERANT!

Failure to use proper service tools may result in equipment damage or personal injury. R-410A operating pressure exceeds the limit of R-22. Proper service equipment is required. Service using only R-410A Refrigerant and approved POE compressor oil.

⚠ WARNING

SAFETY HAZARD!

Operating the unit without the access panels properly installed may result in severe personal injury or death.

Do not operate the unit without the evaporator fan access panel or evaporator coil access panel in place.

⚠ WARNING

WARNING!

This product can expose you to chemicals including lead, which are known to the State of California to cause cancer and birth defects or other reproductive harm. For more information go to www.P65Warnings.ca.gov.

Important: Wear appropriate gloves, arm sleeve protectors and eye protection when servicing or maintaining this equipment.

Important: Air filters and media wheels or plates shall meet the test requirements in UL 900.

Table of Contents

Introduction	4	Electrical Wiring	23
Step 2 – Determine Unit Clearances	5	Field Wiring Diagram	25
Step 3 – Review Location and Recommendation Information.....	11	Step 5 – Unit Startup	26
Step 4 – Unit Installation.....	13	Sequence of Operation	28
		Service Maintenance.....	28

Introduction

Read this manual carefully before attempting to install, operate, or perform maintenance on this unit. Installation and maintenance should be performed by qualified service technicians only. This unit is listed by Underwriters Laboratory. DO NOT use this furnace for temporary heating of buildings under construction.

As shipped from the factory, this unit is for use with natural gas only. It is listed by Underwriters Laboratory. An LPG conversion kit is available. A high altitude installation kit of additional orifice sizes is available. Extreme mounting kits for slab and curbs are also available.

Packaged units are designed for outdoor mounting with a vertical condenser discharge. They can be located either at ground level or on a roof in accordance with local codes or National Fuel Gas Code (ANSI-Z223.1A) Latest Revision. Since these units are designed exclusively for outdoor operation, additional flue venting systems are not required. Each unit contains an operating charge of Refrigerant as shipped. Extreme mounting kits are available for slab (BAYEXMK003A), utility curb (BAYEXMK002B), or curb (BAYEXMK001A) mountings.

The indoor fan motor speed adjustment is provided in the Maintenance section.

This guide is organized as follows:

- Step 1 – Inspect Shipment
- Step 2 – Determine Unit Clearances
- Step 3 – Review Location & Recommendation Information
- Step 4 – Unit Installation
- Step 5 – Unit Startup

- Sequence of Operation
- Maintenance

Step 1 – Inspect Shipment

1. Check for damage after the unit is unloaded. Report promptly to the carrier any damage found to the unit. Do not drop the unit.

Important: *To prevent damage to the sides and top of the unit when hoisting, use "spreader bars".*

2. Check the unit's nameplate to determine if the unit is correct for the intended application. The power supply must be adequate for both the unit and all accessories.
3. Check to be sure the refrigerant charge has been retained during shipment. Remove the Compressor access panel to access the 1/4" flare pressure taps.
4. The Flue Hood is included with the unit's literature pack.
5. If this unit is being installed on a curb, verify that the correct curb is provided with the unit.
 - 4YCC4024–4036 use model BAYCURB050A.
 - 4YCC4042–4060 use model BAYCURB051A.
6. If the unit is being hoisted, accessory kit BAYLIFT002B is recommended. It includes a kit of four (4) lifting lugs and instructions.

Note: *If practical, install any internal accessories to the unit at the shop.*

Note: *The packaged units have been evaluated in accordance with the Code of Federal Regulations, Chapter XX, Part 3280 or the equivalent. "SUITABLE FOR MOBILE HOME USE".*

Step 2 – Determine Unit Clearances

Figure 1. 4YCC4024-4036

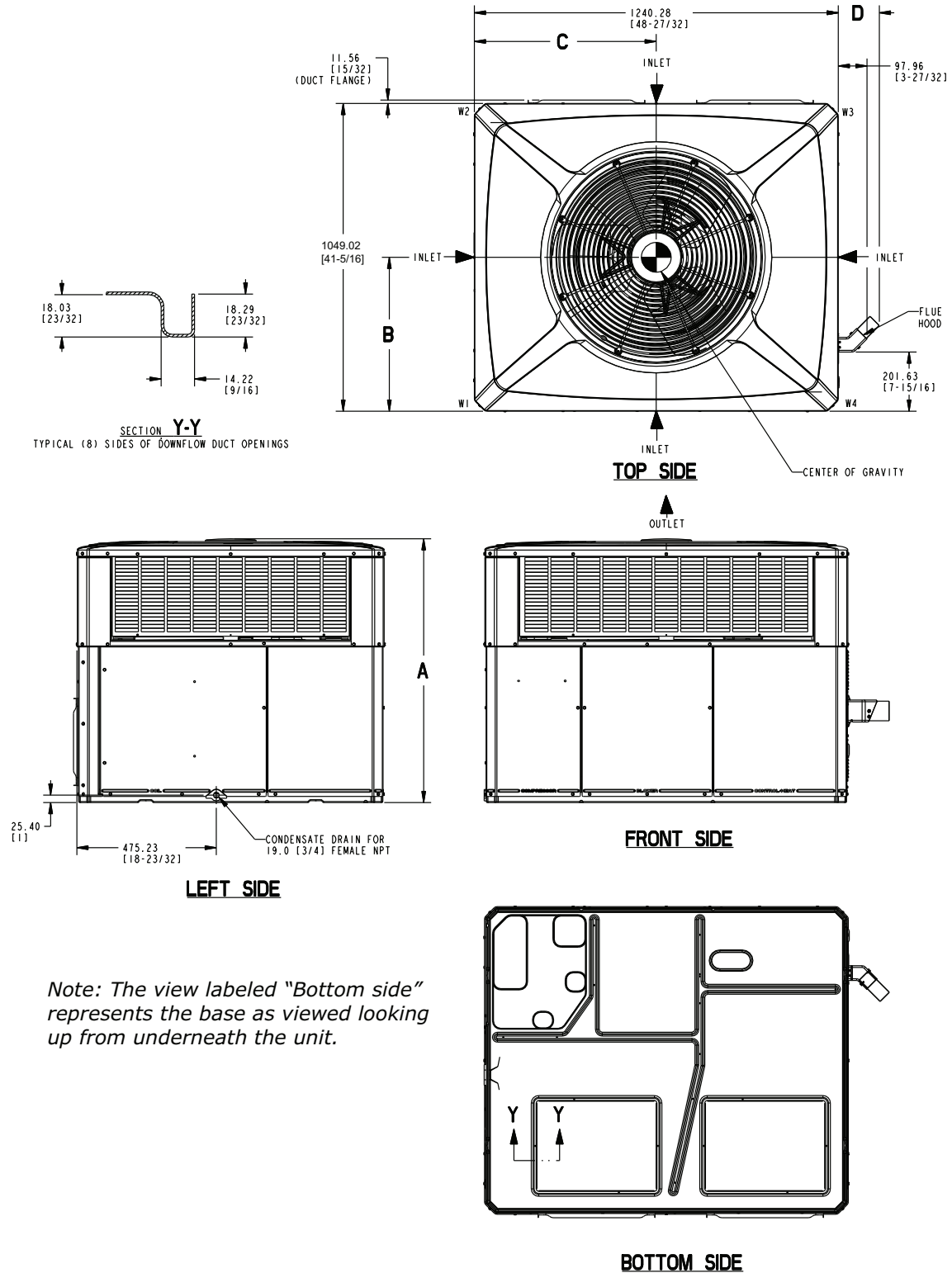

Note: The view labeled "Bottom side" represents the base as viewed looking up from underneath the unit.

Step 2 – Determine Unit Clearances

Figure 2. 4YCC4024-4036

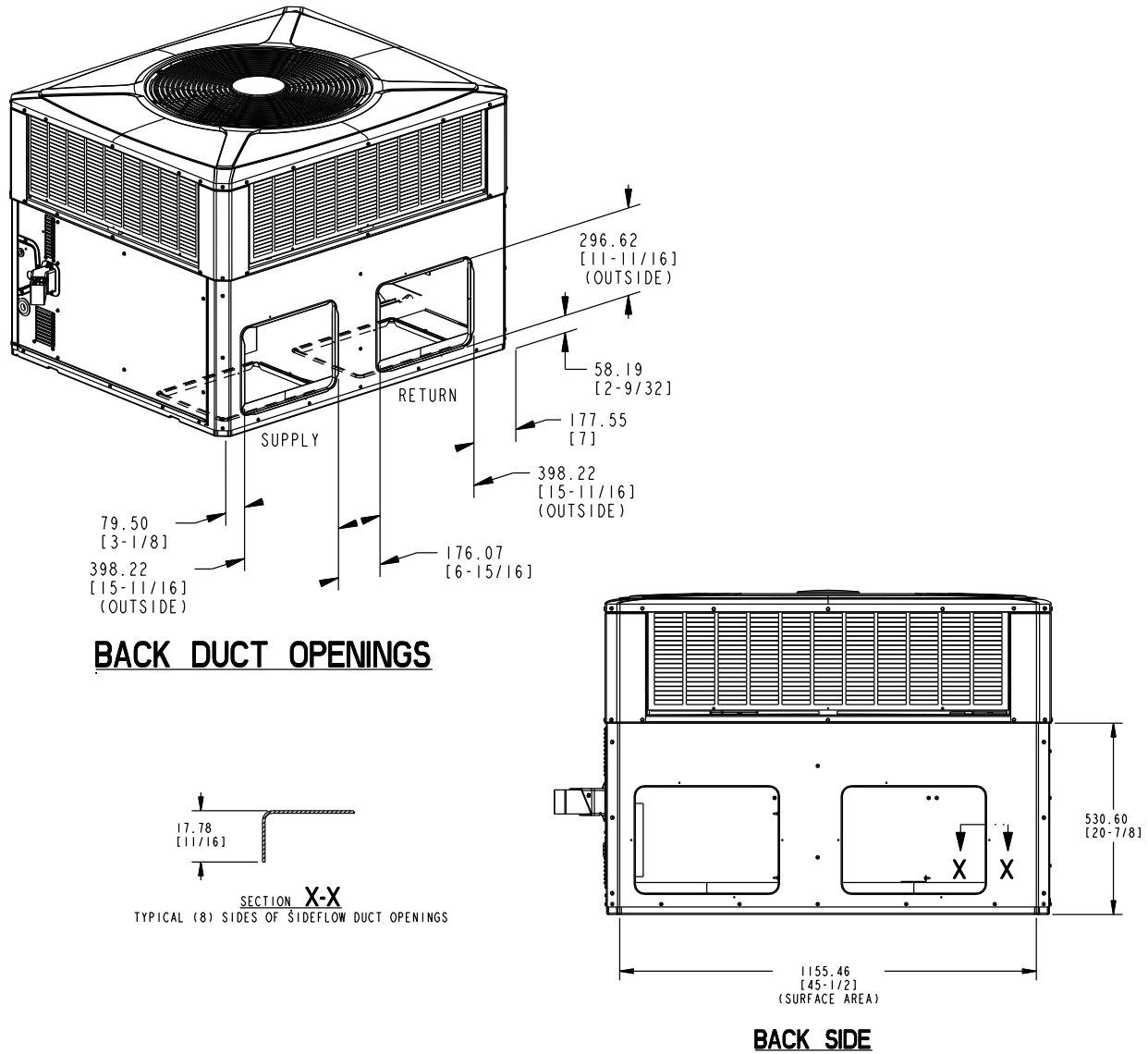

	Height mm/in		Flu Hood w/brkt mm/in				Approx. Corner Weight - kg / lbs				Shipping Weight kg/lbs	Total Unit Weight kg/lbs	Center of Gravity mm/in	
	A	D	W1	W2	W3	W4	B	C						
4YCC4024 (060)	898.53 [35-3/8]	157.16 [6-3/16]	58.3 [129]	36.8 [81]	26.1 [58]	41.0 [90]	196.1 [432]	162.4 [358]	479.8 [18.9]	527.8 [20.8]				
4YCC4030 (070)	898.53 [35-3/8]	157.16 [6-3/16]	61.3 [135]	38.7 [85]	27.5 [61]	43.1 [95]	204.8 [451]	171.1 [377]	406.5 [16.0]	594.1 [23.4]				
4YCC4036 (070)	949.33 [37-3/8]	157.16 [6-3/16]	61.1 [134]	38.3 [84]	27.1 [60]	43.2 [95]	203.4 [438]	169.7 [374]	414.3 [16.3]	697.6 [27.5]				
4YCC4036 (090)	949.53 [37-3/8]	157.16 [6-3/16]	61.7 [136]	38.9 [86]	27.7 [61]	43.7 [96]	205.7 [453]	172.0 [379]	414.3 [16.3]	697.6 [27.5]				

Figure 3. 4YCC4024-4036

RECOMMENDED SERVICE CLEARANCE MM/IN.		
		WITH ECONOMIZER
BACK SIDE	304.8 [12]	762.0 [30]
LEFT SIDE	762.0 [30]	914.4 [36]
RIGHT SIDE	914.4 [36]	-
FRONT SIDE	1066.8 [42]	-

CLEARANCE TO COMBUSTIBLE MATERIAL MM/IN.	
BOTTOM	0
BACK SIDE	25.4 [1]
LEFT SIDE	152.4 [6]
RIGHT SIDE	152.4 [6]
FRONT SIDE	304.8 [12]
TOP	914.4 [36]

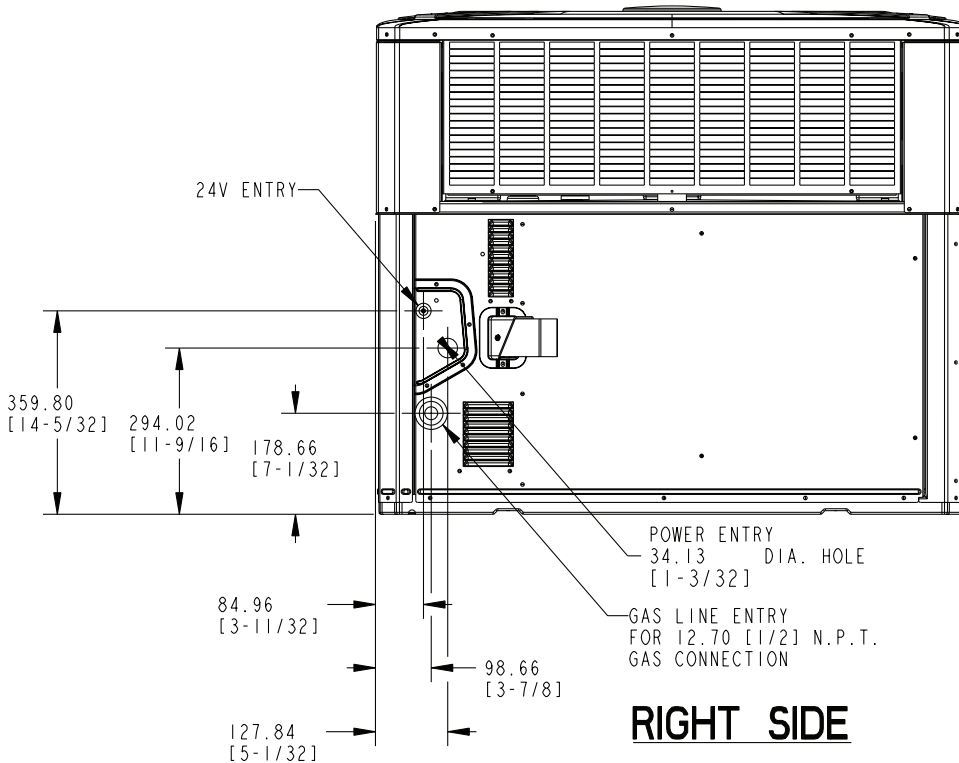
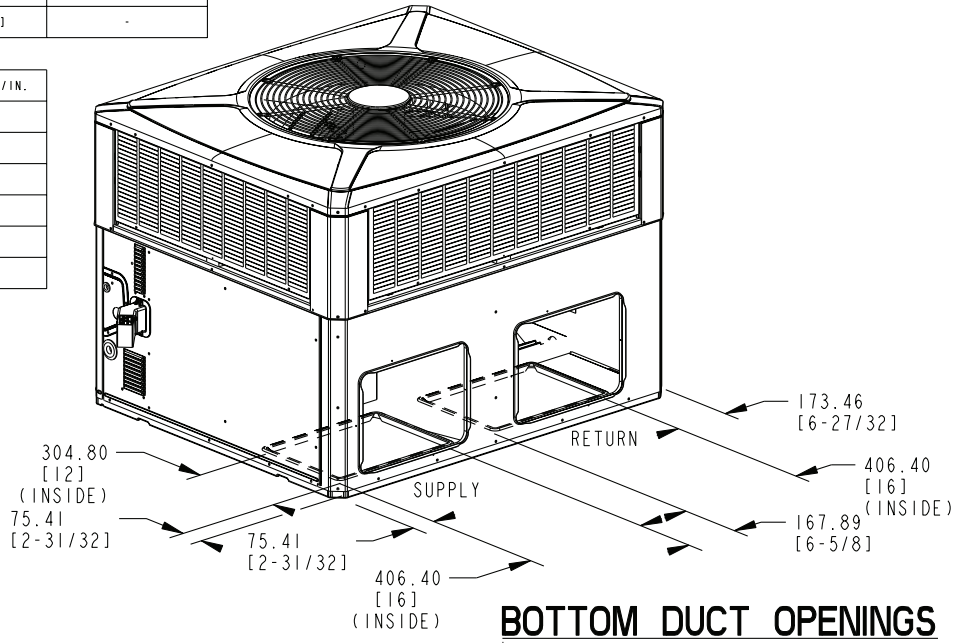

Step 2 – Determine Unit Clearances

Figure 4. 4YCC4042-4060

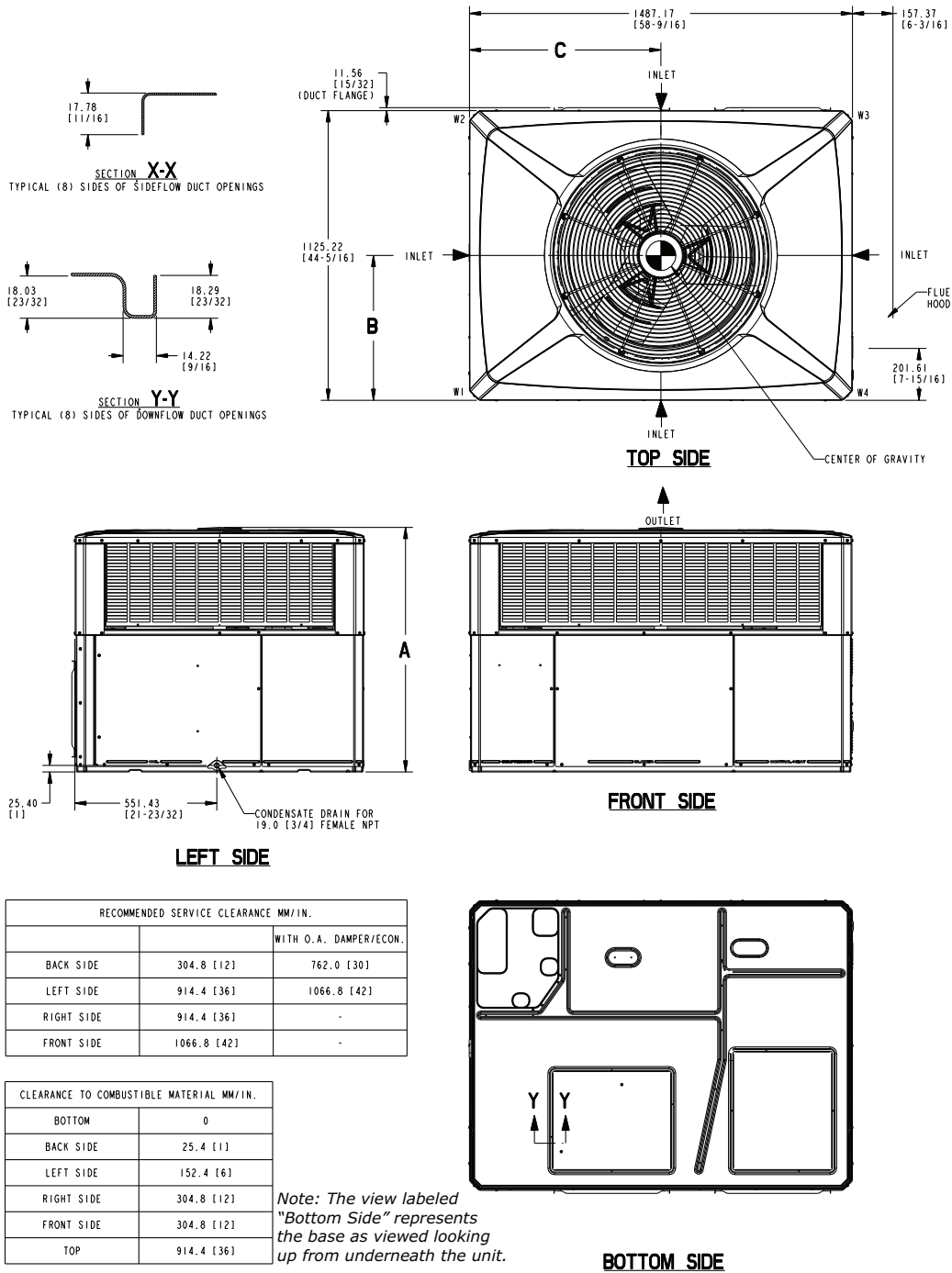

RECOMMENDED SERVICE CLEARANCE MM/IN.		
		WITH O.A. DAMPER/ECON.
BACK SIDE	304.8 [12]	762.0 [30]
LEFT SIDE	914.4 [36]	1066.8 [42]
RIGHT SIDE	914.4 [36]	-
FRONT SIDE	1066.8 [42]	-

CLEARANCE TO COMBUSTIBLE MATERIAL MM/IN.	
BOTTOM	0
BACK SIDE	25.4 [1]
LEFT SIDE	152.4 [6]
RIGHT SIDE	304.8 [12]
FRONT SIDE	304.8 [12]
TOP	914.4 [36]

Note: The view labeled "Bottom Side" represents the base as viewed looking up from underneath the unit.

Figure 5. 4YCC4042-4060

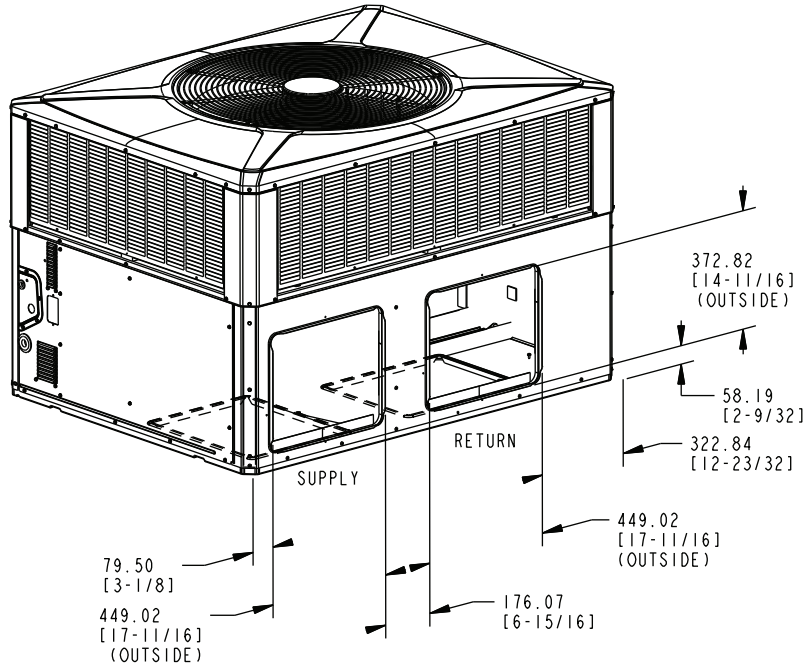

BACK DUCT OPENINGS

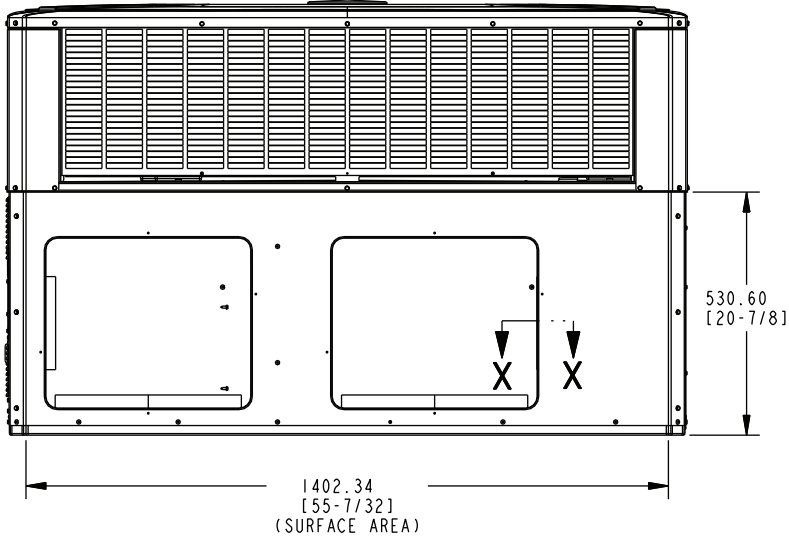

BACK SIDE

Model	Height mm/in	Approx. Corner Weight - kg / lbs				Shipping Weight kg/lbs	Total Unit Weight kg/lbs	Center of Gravity mm/in	
	A	W1	W2	W3	W4			B	C
4YCC4042 (060)	898.53 [35-3/8]	71.2 [157]	46.6 [103]	34.6 [76]	53.1 [117]	252.2 [555]	202.0 [452]	470.0 [18.5]	731.0 [28.8]
4YCC4042 (090)	898.53 [35-3/8]	71.8 [158]	47.2 [104]	35.2 [78]	53.6 [118]	254.5 [561]	207.3 [457]	470.0 [18.5]	731.0 [28.8]
4YCC4048 (070)	1000.13 [39-3/8]	71.4 [157]	44.6 [98]	33.2 [73]	53.9 [119]	250.3 [552]	202.1 [448]	433.0 [17.0]	743.3 [29.3]
4YCC4048 (090)	1000.13 [39-3/8]	72.0 [159]	45.0 [99]	33.8 [75]	54.4 [120]	252.6 [557]	205.4 [453]	433.0 [17.0]	743.3 [29.3]
4YCC4060 (090)	1000.13 [39-3/8]	77.1 [170]	45.8 [101]	34.4 [76]	58.3 [128]	263.1 [580]	215.9 [476]	433.0 [17.0]	743.3 [29.3]
4YCC4060 (115)	1000.13 [39-3/8]	78.0 [172]	46.3 [102]	34.9 [77]	59.0 [130]	265.8 [586]	218.6 [482]	414.0 [16.3]	635.0 [25.0]

Step 2 – Determine Unit Clearances

Figure 6. 4YCC4042-4060

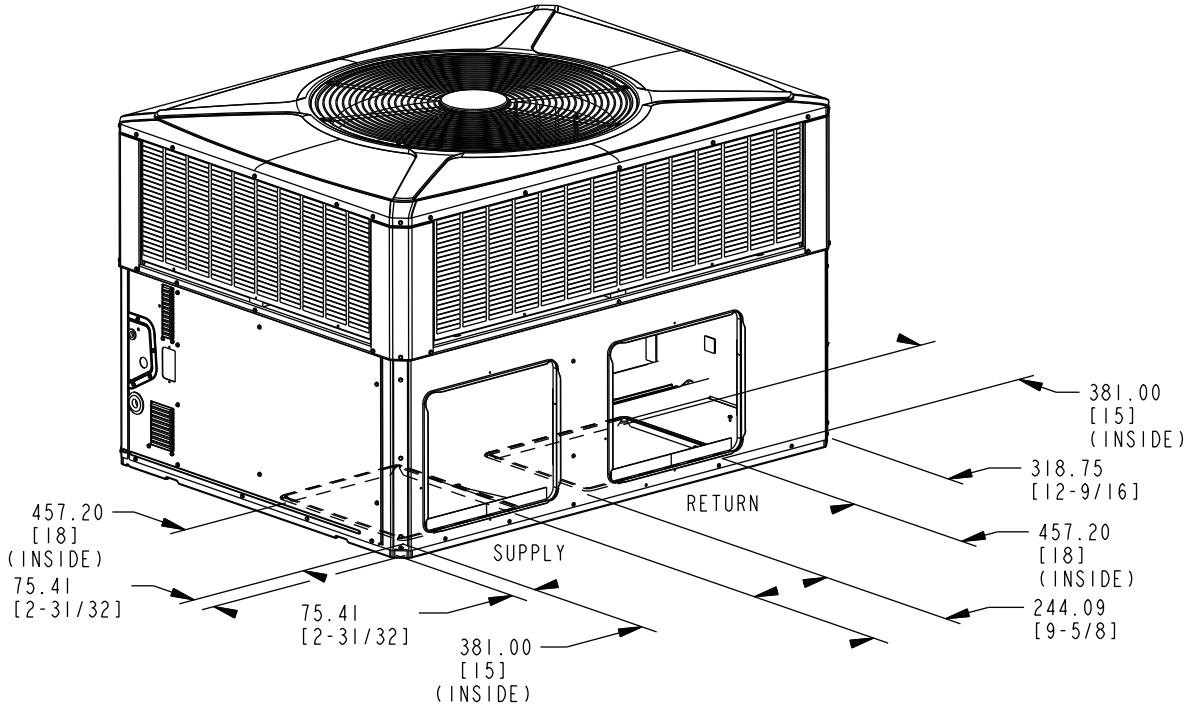

BOTTOM DUCT OPENINGS

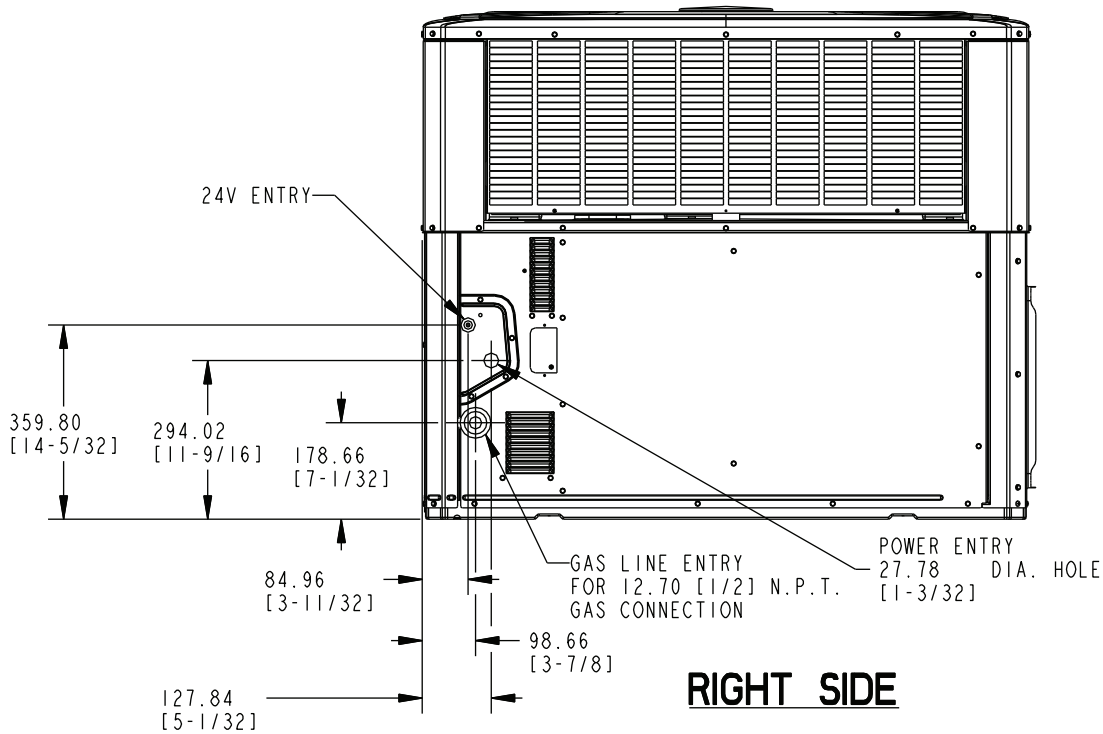

RIGHT SIDE

Step 3 – Review Location and Recommendation Information

Note: The unit is shipped for horizontal installation.

Note: During heating operation, avoid supply air below 80 degrees F or return air below 50 degrees F to prevent flue gas condensation.

Horizontal Airflow Units

1. Location of the unit must allow service clearance around it to ensure adequate serviceability, maximum capacity, and peak operating efficiency.
2. These units are designed for outdoor installation. They may be installed directly on a slab, wood flooring, or on Class A, B, or C roof covering material. The discharge air from the condenser fans must be unrestricted for a minimum of 3 feet above the unit.
3. The louvers above and below the flue hood in the side panel must have adequate clearance around the air opening into the combustion area.
4. Examine all flue product-carrying areas of the furnace, its vent system, and the main burner for safe operation.

Important: A minimum clearance of 0.0" to combustible material shall be maintained on air outlet duct.

5. Exhaust vents or other sources of contaminated air must not be near the unit's air inlet if outside air is to be introduced as make-up air or a ventilation feature is to be used. Contamination from exhaust vents or chimneys may also foul the condenser causing degraded performance.
6. Check the handling facilities to ensure the safety of personnel and the unit(s).
7. The unit must be mounted level for proper drainage of water through the drain holes in the base pan.
8. The unit should not be exposed to direct roof water runoff.
9. Flexible duct connectors must be of a flame retardant material. All duct work outside of the structure must be insulated and weatherproofed in accordance with local codes.
10. Holes through exterior walls or roof must be sealed in accordance with local codes.
11. All fabricated outdoor ducts should be as short as possible.

Clearances

1. The recommended clearances for single-unit installations are illustrated in Figures 1 to 6.
2. Any reduction of the unit clearances indicated in these figures may result in condenser coil starvation or the recirculation of warm condenser

air. Actual clearances, which appear to be inadequate should be reviewed with a local engineer.

3. See the unit's nameplate for the absolute minimum clearance between the unit and any combustible surfaces.

Down Airflow Units

1. Location of the unit must allow service clearance around it to ensure adequate serviceability, maximum capacity, and peak operating efficiency.
2. Refer to the Installation section for instruction on converting the supply and return airflow covers to down airflow.
3. The field assembled Roof Mounting Curb (BAYCURB050A or BAYCURB051A) or a field fabricated curb should be in place before the unit is hoisted to the roof top. The Roof Mounting Curb (frame) must be installed on a flat, level section of the roof (maximum of 1/4" per foot pitch) and provide a level mounting surface for the unit. Also, be sure to provide sufficient height above the roof to prevent water from entering the unit.
4. Be sure the mounting curb spans structural members (trusses) of the roof, thereby providing sufficient support for the weight of the unit, the curb, the duct(s), and any factory or field installed accessories.
5. The unit must be mounted level for proper drainage of water through the drain holes in the base pan.
6. Be sure the hole in the structure for the ducts is large enough to accommodate the fabricated ducts and the insulation surrounding them. Flexible duct connectors must be of a flame retardant material. All duct work outside of the structure must be insulated and weatherproofed in accordance with local codes.
7. Holes through exterior walls or roof must be sealed in accordance with local codes.
8. These units are design certified for outdoor installation. They may be installed directly on a slab, wood flooring, or on Class A, B, or C roof covering material. The discharge air from the condenser fans must be unrestricted for a minimum of 3 feet above the unit.
9. The louvers above and below the flue hood in the side panel must have adequate clearance around the air opening into the combustion area.
10. Examine all flue product-carrying areas of the furnace, its vent system, and the main burner for safe operation.

Step 3 – Review Location and Recommendation Information

Important: *A minimum clearance of 0.0" to combustible material shall be maintained on air outlet duct.*

11. Exhaust vents or other sources of contaminated air should not be near the unit's air inlet if outside air is to be introduced as make-up air or a ventilation feature is to be used. Contamination from exhaust vents or chimneys may also foul the condenser causing degraded performance.
12. Check the handling facilities to ensure the safety of personnel and the unit(s).

Clearances

1. The recommended clearances for single-unit installations are illustrated in Figures 1 to 6.
2. Any reduction of the unit clearances indicated in these figures may result in condenser coil starvation or the recirculation of warm condenser air. Actual clearances, which appear to be inadequate should be reviewed with a local engineer.
3. See the unit's nameplate for the absolute minimum clearance between the unit and any combustible surfaces.

Step 4 – Unit Installation

Note: The factory ships this unit for horizontal installation.

Install Flue Hood

1. Locate the Flue Hood in the literature package.
2. Remove the two Flue Hood mounting screws from the unit. They are located to the right of the Power Entry connection panel.
3. Attach the Flue Hood to the unit with the two screws removed in step two.

To Install the unit at ground level:

1. Place the unit on a pad the size of the unit or larger. The unit must be mounted level for proper drainage of water through the holes in the base pan. To attach the unit securely to the slab, use extreme mounting kit, BAYEXMK003A. The pad must not come in contact with the structure. Be sure the outdoor portion of the supply and return air ducts are as short as possible. The unit requires vibration support as indicated in the Ground Level Application Figure.
2. The louvers above and below the Flue Hood in the side panel must have adequate clearance around the air opening into the combustion area.
3. Location of the unit must allow service clearance around it. Clearance of the unit must be given careful consideration. See Figures 1 to 6

Note: Any reduction of the unit clearances indicated in these illustrations may result in condenser coil starvation or the recirculation of warm condenser air. Actual clearances, which appear to be inadequate should be reviewed with a local engineer.

Important: A minimum clearance of 0.0" to combustible material shall be maintained on air outlet duct.

4. Attach the supply and return air ducts to the unit as explained in the Ductwork Installation section.

5. Flexible duct connectors must be of a flame retardant material. Insulate any ductwork outside of the structure with at least two (2) inches of insulation and weatherproof. There must be a weatherproof seal where the duct enters the structure.
6. Do not expose the unit to direct roof water runoff.
7. Seal all holes through exterior walls in accordance with local codes.
8. Continue with the following installation sections to complete the installation: Ductwork, Gas Piping, Filter and Electrical Wiring.

Rooftop Installation – Curb Mounting Convert Horizontal Airflow to Down Airflow

The factory ships the unit for horizontal airflow. Perform this procedure to convert it to down airflow:

1. Remove the three (3) sheet metal screws securing the supply air cover and the four (4) sheet metal screws securing the return air cover from the base of the unit. Remove the covers from the base.
2. Place the covers over the horizontal supply and return openings (painted side out). Align the screw holes, and secure using the same screws removed in step 1.

Install Full Perimeter Roof Mounting Curb

1. Verify that the roof mounting curb is correct for the unit. There are two curbs depending on the unit cabinet sizes:
 - 4YCC4024 through 4YCC4036 use model BAYCURB050A
 - 4YCC4042 through 4YCC4060 use model BAYCURB051A
2. Assemble and install the curb following the instructions in the Installer's Guide included with the appropriate curb.

Step 4 – Unit Installation

Figure 7. Typical Ground Level Application

Note: Use the extreme mounting kit, BAYEXMK003AA, to secure the unit to the slab.

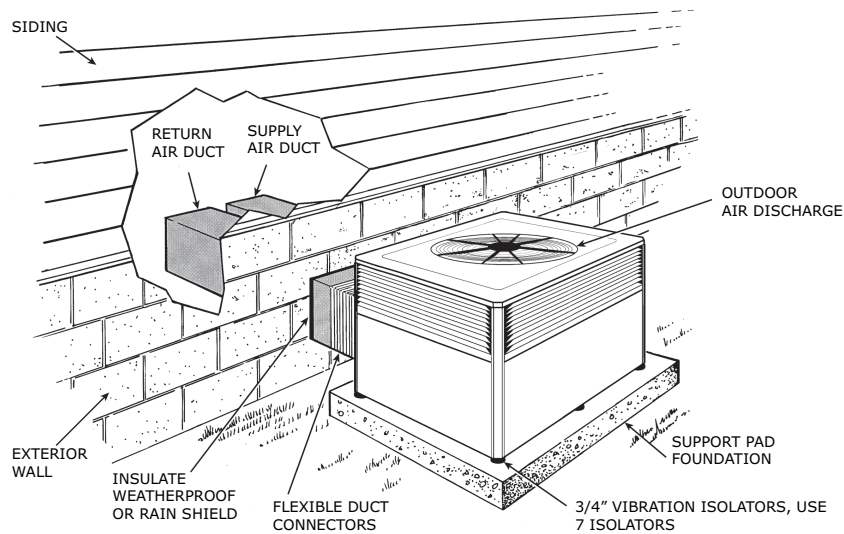
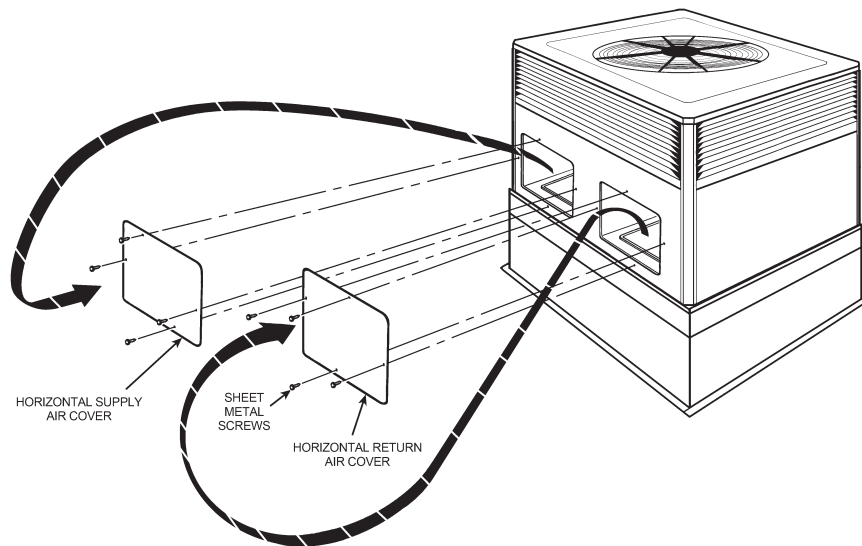

Figure 8. Converting Horizontal to Down Airflow



Lifting and Rigging

Important: Do not lift the unit without test lifting for balance and rigging. Do not lift the unit in windy conditions or above personnel. Do not lift the unit by attaching clevis, hooks, pins, or bolts to the unit casing, casing hardware, corner lugs, angles, tabs, or flanges. Failure to observe these warnings may result in equipment damage.

1. Before preparing the unit for lifting, check the unit dimension drawings for center of gravity for lifting safety (Figures 1 to 6). Because of placement of internal components, the unit's weight may be unevenly distributed. Approximate unit weights are also provided in the unit drawings

Note: Unit rigging and hoisting requires accessory kit BAYLIFT002A. It includes a kit of four (4) lifting lugs.

2. Insert the four lifting lugs in the openings provided in the drip lip on each end of the unit. A tap or jerk to the lug will overcome the interference that arises due to the dimple on the lug.
3. When hoisting the unit, be sure that a proper method of rigging is used. Use slings and spreader bars for protection during lifting. Always test-lift the unit to determine the exact unit balance and stability before hoisting it to the installation location.

- When the curb and air ducts have been properly installed, the unit is ready to be hoisted to the roof and set in position.

Important: To prevent damage to the sides and top of the unit when hoisting use “spreader bars”.

Important: The unit must be lowered into position. The P.V.C. rubber tape on the curb flange permits the unit to be repositioned if required without destroying the P.V.C. rubber seal affixed to the mounting curb.

Placing the Unit on the Mounting Curb

- The unit is designed with a perimeter drip lip that is lower than the unit base pan.
- Position the unit drip lip down over and in contact with the outside corner of the curb.. Continue to lower the unit on top of the curb, with the unit drip lip astraddle, and in contact with, both the end and side rail of the curb. The unit should now rest on top of the curb. Use the extreme mounting kit, BAYEXMK001A, to add additional hold down strength to the mounting.

Note: The ductwork is installed as part of the curb installation. Do not attach ductwork to the unit and lower the unit with ductwork onto the curb.

Table 1. Vibration Isolators/Snow Feet Locations

<p>Note: These views represent the base as viewed looking up from underneath the unit.</p>		
<p>Important: Unit requires vibration isolator support in the general areas shown. Locate 3/4" thick vibration isolators on the bottom of the basepan as illustrated by black dots for ground level pad applications. Modify vibration isolator location as necessary for frame and rail applications.</p>		
	<p>Small Cabinet ***4024 - 4036</p>	<p>Medium Cabinet ***4042 - 4060</p>

Rooftop Installation — Frame Mounting

For rooftop applications using field fabricated frame and ducts use the following procedure:

- Locate and secure the frame to the roof by bolting or welding. Frame must provide adequate center support via a cross member centrally located channel rail. See [Table 4, p. 17](#) and [Table 5, p. 18](#). Vibration isolators should be installed as indicated in [Table 1, p. 15](#), adjust as necessary for your frame. The isolators must be placed on base pan, not drip lip. Add flashing as required. Flashing must conform to local building codes.
- Prepare the hole in the roof in advance of installing the unit.
- Secure the horizontal or down airflow ducts to the roof. Refer to the previous Convert from Horizontal Airflow to Down Airflow section if conversion is needed.
- All fabricated outdoor ducts should be as short as possible.
- Place the unit on the frame.
- The unit must be mounted level for proper drainage of water through the holes in the base pan.
- Secure the unit to the frame.
- Insulate any ductwork outside of the structure with at least two (2) inches of insulation and then weatherproof. There must be a weatherproof seal where the duct enters the structure.
- The unit should not be exposed to direct roof water runoff.
- Flexible duct connectors must be of a flame retardant material. All duct work outside of the structure must be insulated and weatherproofed in accordance with local codes.
- Access and service clearances for the unit must be given careful consideration when locating the duct entrance openings. Figures 1 to 6 provide unit dimensions.
- Continue with the following installation sections to complete the installation: Ductwork, Filter, and Electrical Wiring.

Step 4 – Unit Installation

Rooftop Installation – Flat Roof-No Curb/Frame

For roof top applications using field fabricated ducts and sleeper rails rather than a curb or frame, use the following procedure:

1. Locate and secure the sleeper rails to the roof by bolting (three (3) rails required). One on each end to support the edges of the unit and one across the center of the unit. The center rail must run inside both drip lips. Vibration isolators should be installed, adjust as necessary for your sleeper rails. The isolators must be placed on base pan, not drip lip. Add flashing as required. Flashing must conform to local building codes.
2. Prepare the hole in the roof in advance of installing the unit.
3. Secure the horizontal or down airflow ducts to the roof. Refer to the previous Convert from Horizontal Airflow to Down Airflow section if conversion is needed.
4. All fabricated outdoor ducts should be as short as possible.
5. Place the unit on the rails.
6. The unit must be mounted level for proper drainage of water through the holes in the base pan.
7. Secure the unit to the rails.
8. Insulate any ductwork outside of the structure with at least two (2) inches of insulation and then weatherproof. There must be a weatherproof seal where the duct enters the structure.
9. No exposure to direct roof water runoff.
10. Flexible duct connectors must be of a flame retardant material. All duct work outside of the structure must be insulated and weatherproofed in accordance with local codes.
11. Access and service clearances for the unit must be given careful consideration when locating the duct entrance openings. Figures 1 to 6 provide unit dimensions.
12. Continue with the following installation sections: Ductwork, Filter and Electrical Wiring.

Table 2. Lifting and Rigging

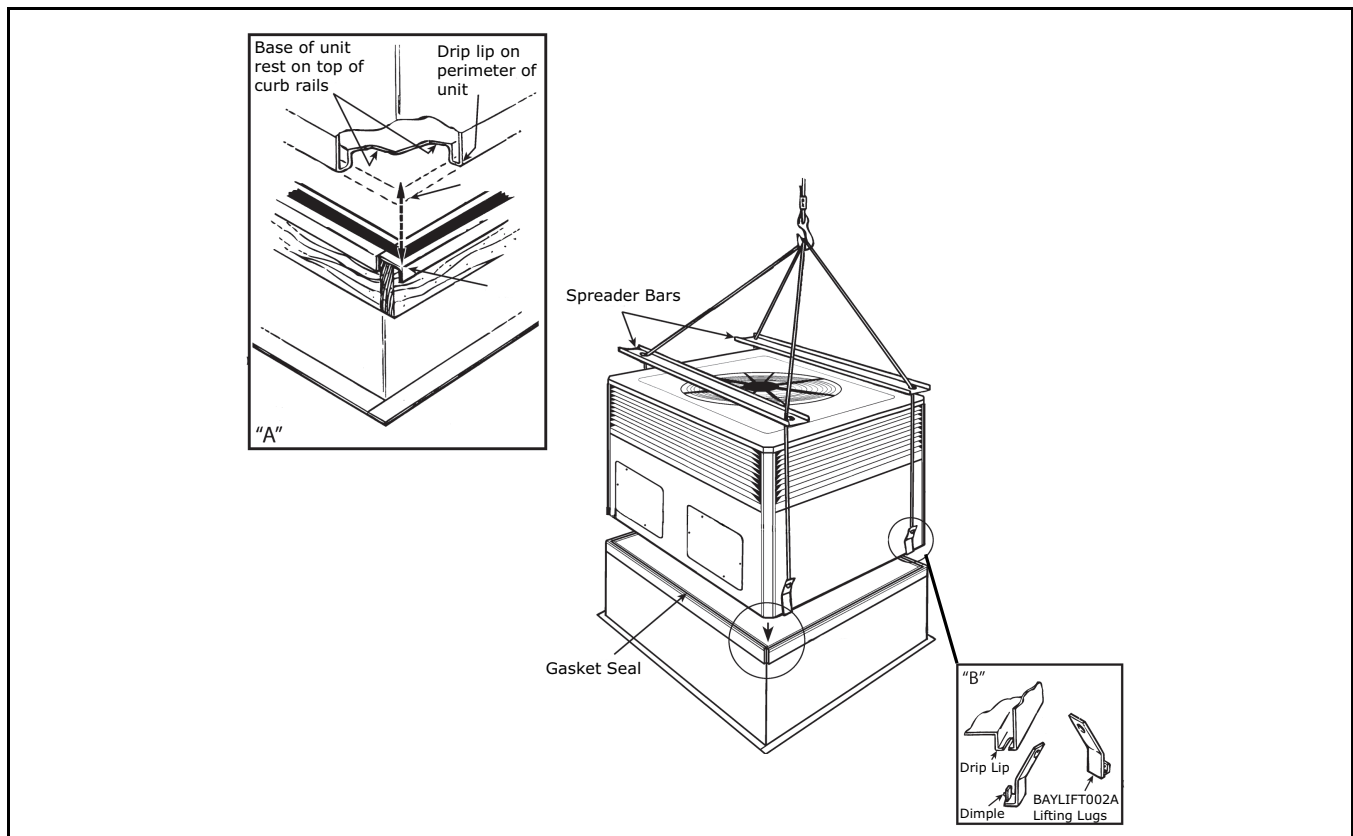

Table 3. Curb Dimensions

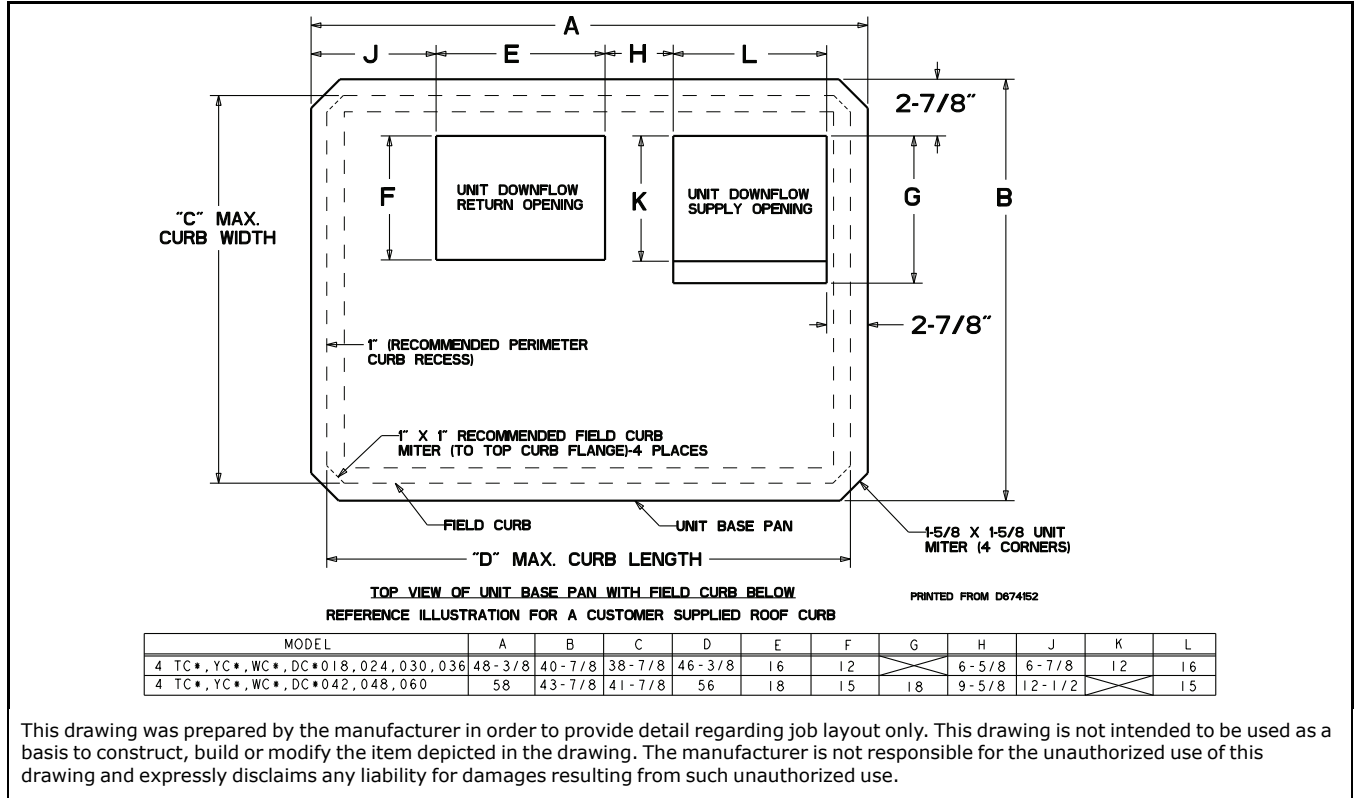
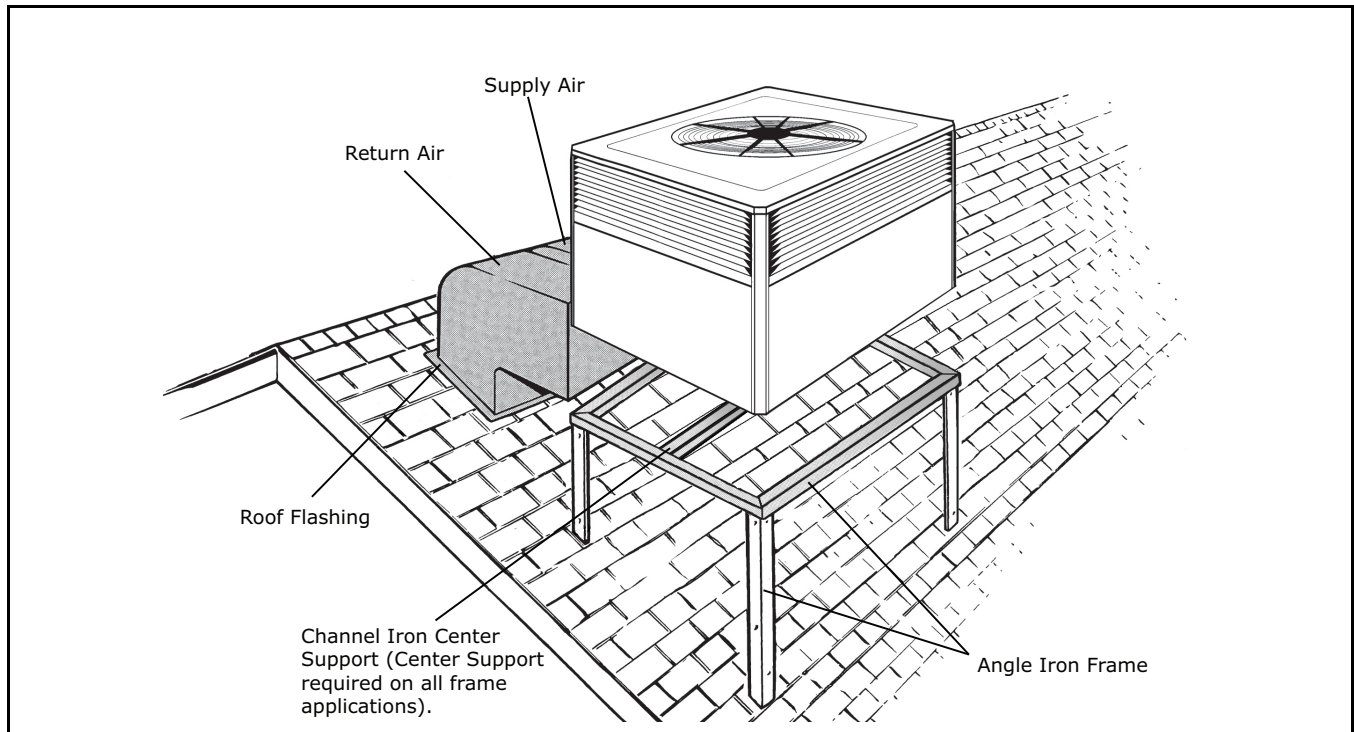
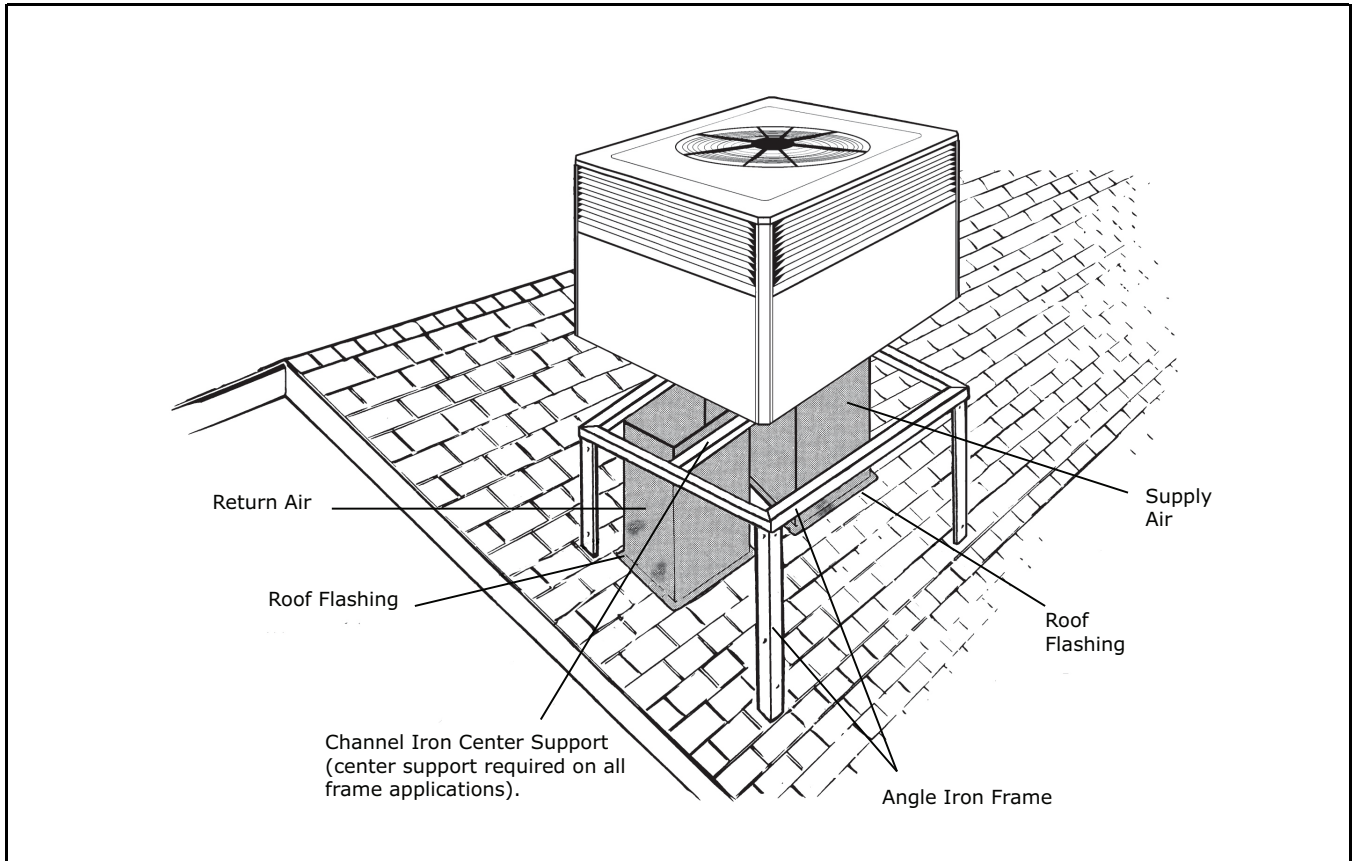

Table 4. Typical Rooftop Horizontal Airflow Application with Frame



Step 4 – Unit Installation

Table 5. Typical Rooftop Down Airflow Application with Frame



Ductwork Installation

Attaching Downflow Ductwork to Roof Curb

Supply and return air flanges are provided on the roof curb for easy duct installation. All ductwork must be run and attached to the curb before the unit is set into place.

Attaching Downflow Ductwork to Roof Frame

Follow these guidelines for ductwork construction:

Connections to the unit should be made with three (3) inch canvas connectors to minimize noise and vibration transmission.

Elbows with turning vanes or splitters are recommended to minimize air noise and resistance.

The first elbow in the ductwork leaving the unit should be no closer than two (2) feet from the unit, to minimize noise and resistance.

To prevent leaking, do not attach the ductwork to the bottom of the unit base. Refer to the bottom example in [Figure 9, p. 18](#)

Figure 9. Attaching Down Airflow Ductwork

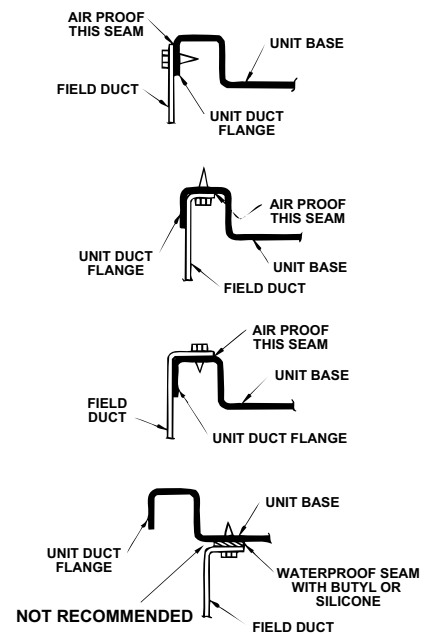

Attaching Horizontal Ductwork to Unit

All conditioned air ductwork should be insulated to minimize heating and cooling duct losses. Use a minimum of two (2) inches of insulation with a vapor barrier. The outside ductwork must be weatherproofed between the unit and the building.

When attaching ductwork to a horizontal unit, provide a flexible watertight connection to prevent noise transmission from the unit to the ducts. The flexible connection **must** be indoors and made out of heavy canvas.

Note: Do not draw the canvas taut between the solid ducts.

Figure 10. Attaching Horizontal Airflow Ductwork

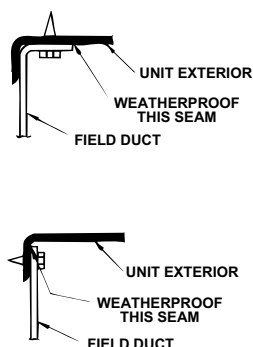

Condensate Drain Piping

A 3/4-inch female NPT condensate drain connection is provided on the evaporator access panel end of the unit. Provide a trap and fill it with water before starting the unit to avoid air from being drawn through. Follow local codes and standard piping practices when running the drain line. Pitch the line downward away from the unit. Avoid long horizontal runs. See .

Note: Do not use reducing fittings in the drain lines.

The condensate drain must be:

- Made of 3/4" pipe size
- Pitched 1/4" per foot to provide free drainage to convenient drain system
- Trapped
- Must be connected to a closed drain system unless the trap is properly vented

Figure 11. Typical Condensate Drain Piping

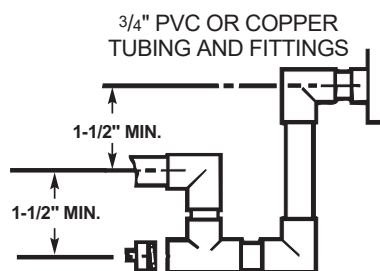

Gas Piping Installation

⚠ WARNING

FIRE OR EXPLOSION HAZARD!

Failure to follow the safety warning exactly could result in serious injury, death, or property damage.

Use a commercially available soap solution made specifically for the detection of leaks to check all connections.

Important: Before making the gas pipe connection, give serious consideration to providing the clearance necessary to remove the access panels on the unit (e.g., economizer and filter access panels).

Note: In the absence of local codes, the installation must conform with American National Standard—Z223.1—National Fuel Gas Code, Latest Revision.

The available gas supply must agree with the required gas supply marked on the unit nameplate. Minimum permissible gas supply pressure for purpose of input adjustment must be at least 7.0 in. w. c. (inches water column) for natural gas and 11 in. w. c. for LP Gas.

Pipe Delivery Schedule

Note: The following procedure and tables apply to Natural Gas only.

1. Obtain from the gas company the heating value and specific gravity of the gas delivered.
2. Determine the exact length of pipe needed.
3. Read BTUH input nameplate on the furnace.
4. Use the multiplier opposite the specific gravity of the gas given in Multiplier Table and insert in the following formula:
5. Use the Natural Gas Only table and select the pipe length nearest to calculated size.

$$CFH = \frac{\text{Furnace Input in BTUH}}{\text{Gas Heat Content in BTU/Cu. Ft. X Multiplier}}$$

6. Follow this line vertically down to the exact CFH found in Step 4 above or the next highest value.
7. Read horizontally to the left of this column for the required pipe size diameter.

Table 6. Specific Gravity Multiplier

	SPECIFIC GRAVITY	MULTIPLIER
MULTIPLIERS TO BE USED WHEN THE SPECIFIC GRAVITY OF THE GAS IS OTHER THAN 0.060	.50	1.10
	.55	1.04
	.60	1.00
	.65	.962

Note: If this is an LP Gas application, consult your LP Gas supplier for pipe sizes and deliveries.

Step 4 – Unit Installation

Table 7. Natural Gas Only

TABLE OF CUBIC FEET PER HOUR OF GAS FOR VARIOUS PIPE SIZES AND LENGTHS							
PIPE SIZE (inch)							
	10	20	30	40	50	60	70
1/2	132	92	73	63	56	50	46
3/4	278	190	152	130	115	105	96
1	520	350	285	245	215	195	180
1-1/4	1050	730	590	520	440	400	370

THIS TABLE IS BASED ON PRESSURE DROP OF 0.3 INCH W.C. AND 0.6 SP.GR. GAS

Gas Pressure Set-up Precautions

Important: Do not connect gas piping to the unit until a line pressure test has been completed. This unit should never be exposed to gas line pressure in excess of 14 inches water column (1/2 PSIG). The furnace and its equipment shutoff valve must be disconnected from the gas supply piping system during any pressure testing of that system at test pressures in excess of 1/2 psi.

The furnace must be isolated from the gas supply piping system by closing its individual manual shut-off valve during any pressure testing of the gas supply piping system at test pressures less than or equal to 1/2 psig (3.48 kPa).

Gas Supply Line Pressure

Before connecting the unit to the gas supply line, be sure to determine the gas pressure in the line.

If the gas supply pressure is excessive (above 14 inches water column or 1/2 psig), install a pressure regulator either at the supply source or in the branch circuit serving the unit. Once the regulator is installed, set it to provide a pressure of 7 inches water column with the unit operating and no greater than 14 inches water column with the unit not firing.

Note: Gas pressure in excess of 14 inches water column (1/2 psig) may damage the regulator, while improper regulation may result at pressures lower than 5.5 inches water column at the unit inlet.

If the supply line pressure is below the minimum supply pressure indicated on the unit nameplate, contact the gas supply company.

Follow these steps to complete the installation of the unit gas piping. See [Table 8, p. 20](#)

Note: The shut-off gas cock must be installed outside of the unit and should meet the specifications of all applicable national and local codes.

Table 8. Gas Pipe

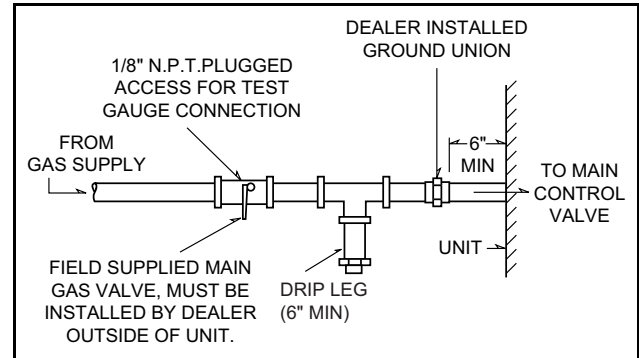

Note: The shut-off gas cock must be installed outside of the unit and should meet the specifications of all applicable national and local code.

1. Install a ground union joint downstream of the shut-off cock. This joint must also be installed outside of the unit.
2. Install a drip leg at least six (6) inches in depth next to the union as shown in . This drip leg is required to collect any sediment that may be deposited in the line.
3. Before connecting the piping circuit to the unit, bleed the air from the supply line and then cap or plug the line and test the pressure at the tapped shut-off cock. The pressure reading should not exceed 13.8 inches water column.
4. Using an appropriate backup wrench on the gas valve inlet boss, connect the gas piping to the unit. Check the completed piping for leaks using a soap and water solution or the equivalent.
5. After installation of the gas pipe in the unit, the pipe opening should be closed with the filler/barrier plug provided.

Verify Manifold Pressure

Check the manifold pressure at the unit gas valve. Do not exceed the recommended pressure shown on the unit nameplate. See for connections. Refer to Manifold Pressure Check and Adjust in the following Step 5-Unit Startup section if adjustment is needed.

Input Check and Adjustment

1. Make sure all gas appliances are off except the furnace.
2. Clock the gas meter with the furnace operating (determine the dial rating of the meter) for one revolution.
3. Match the "Sec" column in the Gas Flow (in cfh) [Table 9, p. 21](#) with the time clocked.
4. Read the "Flow" column opposite the number of seconds clocked.
5. [Table 9, p. 21](#) lists values for a 2 cubic foot dial. For 1, 1/2, or 5 Cu. Ft. dials use the following conversions:

- 1 Cu. Ft. Dial Gas Flow CFH = Chart Flow Reading / 2
 - 1/2 Cu Ft. Dial Gas Flow CFH = Chart Flow Reading / 4
 - 5 Cu. Ft. Dial Gas Flow CFH = 10X Chart Flow Reading / 4
6. Multiply the final figure by the heating value of the gas obtained from the utility company and compare to the nameplate rating. This must not exceed the nameplate rating.
 7. Changes can be made by adjusting the manifold pressure.
 - a. Attach a manifold pressure gauge to the Outlet Pressure Tap.
 - b. Remove the cover screw on top of the gas valve to access the manifold pressure adjustment screw.
 - c. Turn the adjustment screw in to increase the gas flow rate, and out to decrease the gas flow rate using a 3/32" hex wrench or flat-head screwdriver.

Note: For manifold pressures and orifice sizes for gas with other BTU ratings, contact the local gas utility. Manifold pressure should be 3.5 inches water column (+ 0.1). Input for natural gas must **not** exceed the value shown on the rating plate.

Figure 12. Burner and Valve

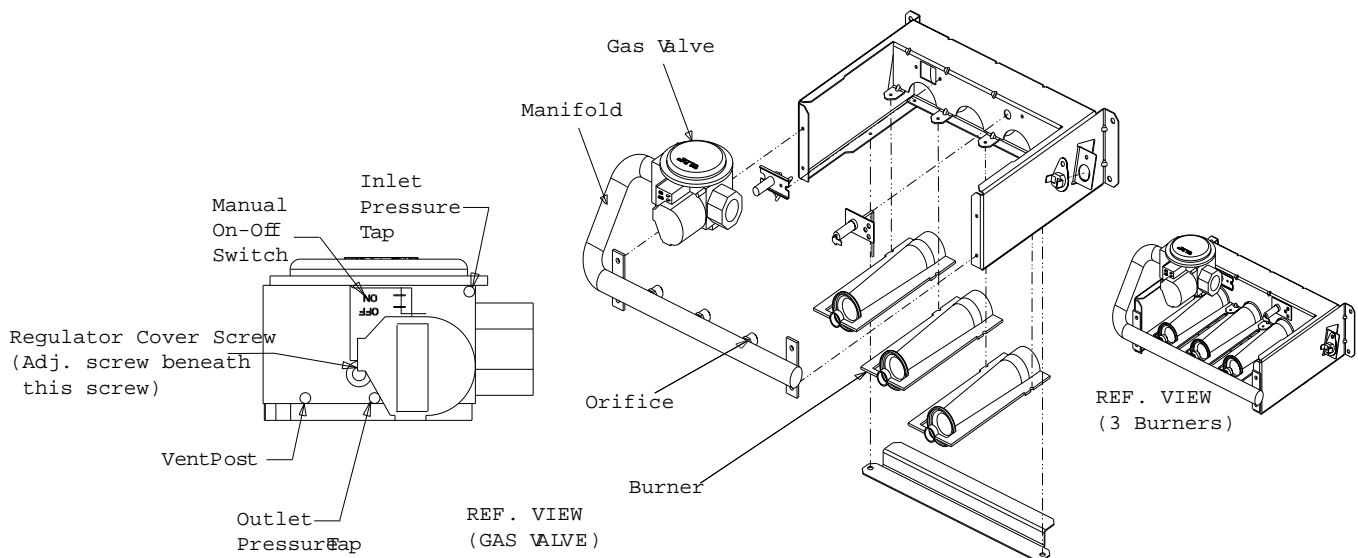

Table 9.

Sec.	Flow	Sec.	Flow	Sec.	Flow	Sec.	Flow
8	900	29	248	50	144	82	88
9	800	30	240	51	141	84	86
10	720	31	232	52	138	86	84
11	655	32	225	53	136	88	82
12	600	33	218	54	133	90	80
13	555	34	212	55	131	92	78
14	514	35	206	56	129	94	76
15	480	36	200	57	126	96	75
16	450	37	195	58	124	98	73
17	424	38	189	59	122	100	72
18	400	39	185	60	120	104	69
19	379	40	180	62	116	108	67
20	360	41	176	64	112	112	64

Table 9. (continued)

Sec.	Flow	Sec.	Flow	Sec.	Flow	Sec.	Flow
21	343	42	172	66	109	116	62
22	327	43	167	68	106	120	60
23	313	44	164	70	103	124	58
24	300	45	160	72	100	128	56
25	288	46	157	74	97	132	54
26	277	47	153	76	95	136	53
27	267	48	150	78	92	140	51
28	257	49	147	80	90	144	50

Step 4 – Unit Installation

High Altitude Installation

Input ratings (BTUH) of these furnaces are based on sea level operation and should not be changed at elevations up to 2000 ft. If the unit installation is from

2000 to 8000 feet elevation, then change the burner orifices to the size listed in Table 4. Refer to Table 5 for orifice part numbers.

Orifice Twist Drill Size if Installed at Sea Level	Altitude Above Sea Level and Orifice Change Required for that Elevation						
	2000	3000	4000	5000	6000	7000	8000
32	33	34	35	35	36	36	37
33	35	35	36	36	37	38	38
37	38	39	39	40	41	42	42
49	50	50	50	51	51	51	52
52	52	53	53	53	53	53	54

From National Fuel Gas Code — Table F-4

Table 10. Orifice Part Numbers

Drill Size	Part Number	Drill Size	Part Number
32	ORF01307	41	ORF01413
33	ORF0134	42	ORF01410
34	ORF01335	49	ORF01333
35	ORF01407	50	ORF01332
36	ORF01408	51	ORF01336
37	ORF01406	52	ORF01331
38	ORF01306	53	ORF01411
39	ORF01409	54	ORF01412
40	ORF01336		

Air Filter Installation

The packaged unit requires an air filter. The unit does not come with a factory installed filter rack in it, however, two filter frame accessories are offered that will allow the installation of a filter within the unit, BAYFLTR101 & BAYFLTR201. Otherwise a field supplied filter rack must be installed by the installer in the return duct work.

Affix the filter label supplied with the unit adjacent to the filter area. Refer to Table 6 to determine filter size.

Table 11. Determine Filter Size

Unit	Nominal CFM	Filter (a) Size (Sq Ft)	Filter (a) Resistance (W.C.)
YC~4024A	800	2.67	0.08
YC~4030A	1000	3.33	0.08
YC~4036A	1200	4	0.08
YC~4042A	1400	4.67	0.08
YC~4048A	1600	5.33	0.08
YC~4060A	2000	6.67	0.08

(a) Filters must be installed in the return air system. The above square footages are based on 300 F.P.M. face velocity. If permanent filters are used, size per mfg. Recommendation with clear resistance of 0.05" WC.

Important: Air filters and media wheels or plates shall meet the test requirements in UL 900

Electrical Wiring

⚠ WARNING

INSTALLATION WARNING — HIGH VOLTAGE MOVING PARTS!

Failure to follow this Warning could result in property damage, severe personal injury, or death.

Bodily injury can result from high voltage electrical components, fast moving fans, and combustible gas. For protection from these inherent hazards during installation and servicing, the main gas valve must be turned off and the electrical supply must be disconnected. If operating checks must be performed with the unit operating, it is the technician's responsibility to recognize these hazards and proceed safely.

Note: This unit is factory wired for 230V. See wiring diagram for 208V conversion.

Electrical Connections

Electrical wiring and grounding must be installed in accordance with local codes or, in the absence of local codes, with the National Electrical Code ANSI/NFPA 70, Latest Revision.

Disconnect Switch

Provide an approved weatherproof disconnect within close proximity and **within sight of the unit**. If disconnect must be mounted to the cabinet, the location shown in [Figure 15, p. 24](#) should be the only one considered.

Over Current Protection

The branch circuit feeding the unit must be protected as shown on the unit's rating plate.

Power Wiring

The power supply lines must be run in weather-tight conduit to the disconnect and into the side of the unit control box. Provide strain relief for all conduit with suitable connectors.

Provide flexible conduit supports whenever vibration transmission may cause a noise problem within the building structure.

1. Remove the Control/Heat access panel. Pass the power wires through the Power Entry hole in the end of the unit. [Figure 13, p. 23](#)
2. Connect the high voltage wires to the appropriate contactor terminals. Single phase units use a two (2) pole contactor and three phase units use three (3) pole contactor. Connect the ground to the ground lug on the chassis. See [Figure 14, p. 23](#).

Be sure all connections are tight.

GROUNDING: THE UNIT MUST BE ELECTRICALLY GROUNDED IN ACCORDANCE WITH LOCAL CODES OR THE NATIONAL ELECTRIC CODE.

Note: Unit must be grounded for ignitor to operate properly. Gas pipe to unit is not an adequate ground. Ground the unit internally as provided. See wiring diagram for location in .

Figure 13. Power Wiring

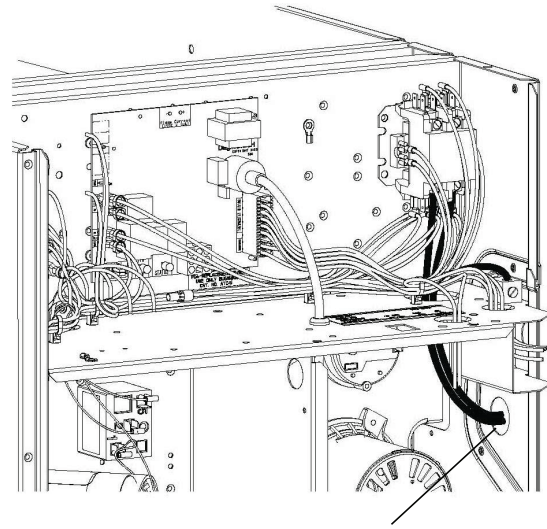

Run power supply lines through weather-tight conduit and secure to unit with strain relief.

Figure 14. Power Connections

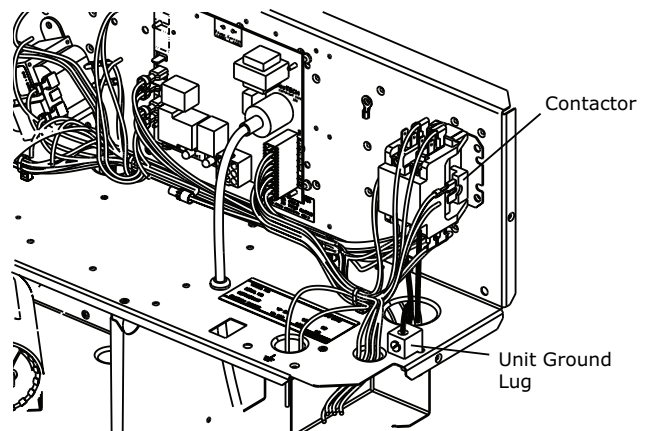

Contactor

Unit Ground Lug

Figure 15. Mounted Disconnect Location

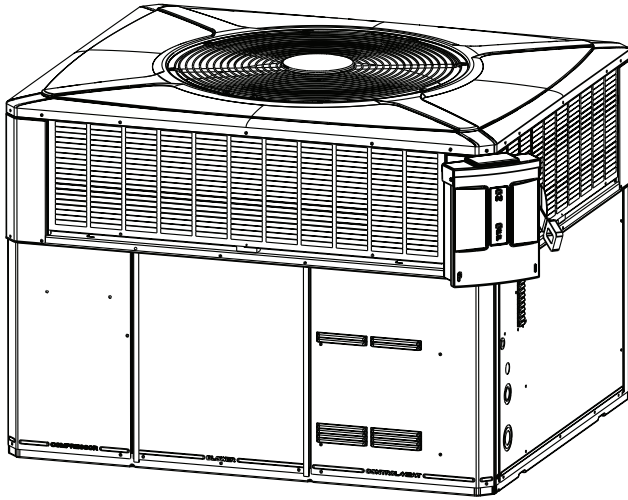

Control Wiring (Class II)

Low voltage control wiring should not be run in conduit with power wiring unless Class 1 wire of proper voltage rating is used. Route the thermostat cable or equivalent single leads of No. 18 AWG colored wire from the thermostat subbase terminals through the rubber grommet on the unit. See Unit Clearance Graphics for the control entry (24V Entry) location. Make connections as shown on the unit wiring diagram.

Do not short thermostat wires since this will damage the control transformer.

Refer to [Table 12, p. 24](#) for recommended wire sizes and lengths for installing the unit thermostat. The total resistance of these low voltage wires must not exceed one (1) ohm. Any resistance in excess of 1 ohm may cause the control to malfunction because of the excessive voltage drop.

Table 12. Thermostat Wire Size and Max. Length

Wire Size	Maximum Length
18	75
16	125
14	200

Thermostat Heat Anticipator

Set the heat anticipator of the thermostat to equal the amperage draw of the gas valve

Important: Upon completion of wiring, check all electrical connections, including factory wiring within the unit.

Make sure all connections are tight. Replace and secure all electrical box covers and access panels before leaving the unit or turning on the power to the unit.

Field Wiring Diagram

Figure 16. 4YCC4 – Field Wiring Diagram

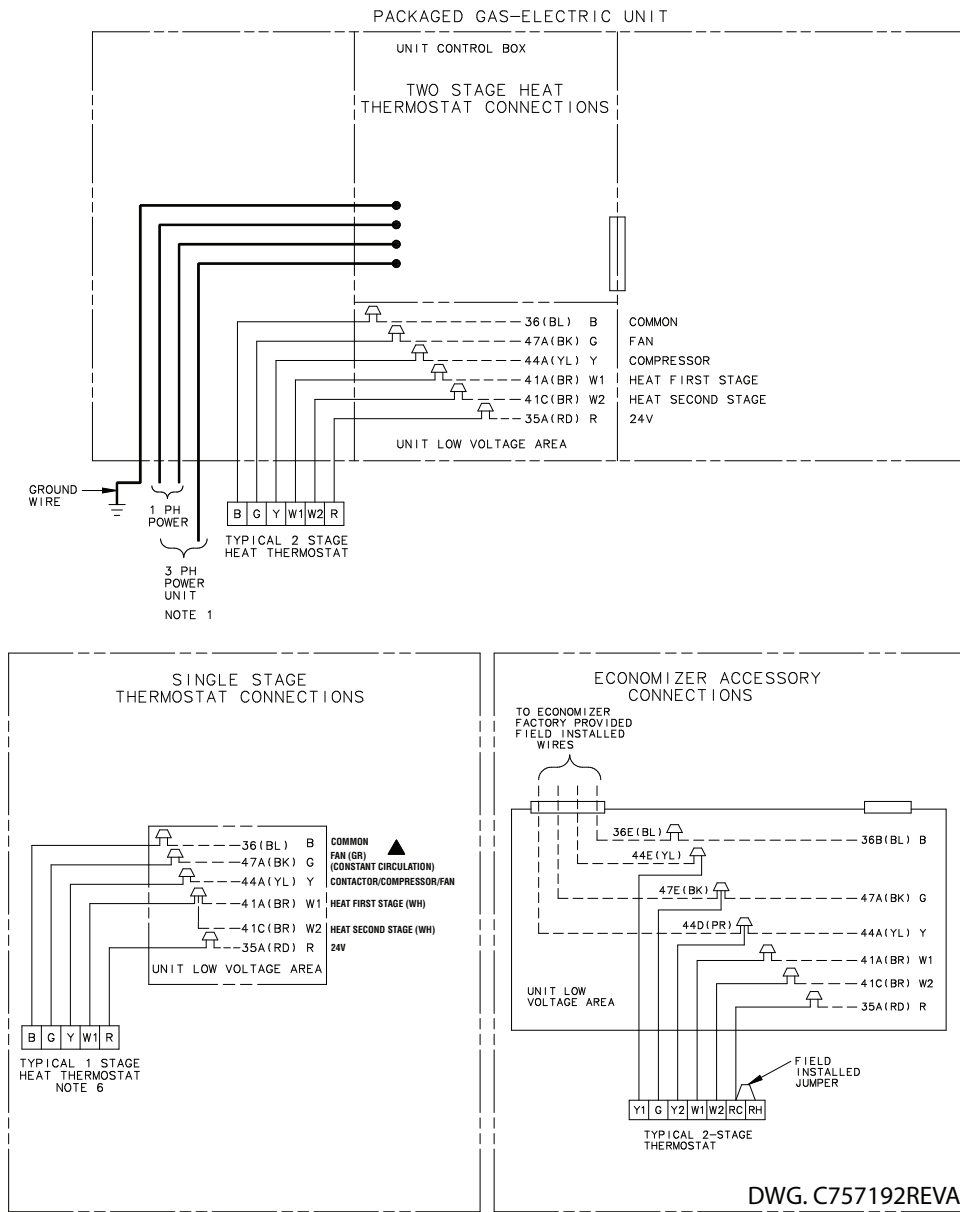

Step 5 – Unit Startup

Pre-Start Quick Checklist

- Is the unit properly located and level with the proper clearances? See Figures 1–6.
- Is the duct work correctly sized, run, taped, insulated, and weatherproofed with proper unit arrangement as shown in the ductwork installation section?
- Is the condensate line properly sized, run, trapped, and pitched and shown in the Condensate Drain Piping section?
- Is the gas piping correctly sized, run, trapped, and purged of air? See Gas Piping Installation section.
- Is the filter of the correct size and quantity? Is it clean and in place? See Air Filter Installation section.
- Is the wiring properly sized and run according to the unit wiring diagram?
- Are all the wiring connections, including those in the unit tight?
- Has the unit been properly grounded and fused with the recommended fuse size?
- Is the thermostat well located, level, and correctly wired? See Electrical Wiring section
- Have the air conditioning systems been checked at the service ports for charge and leak tested if necessary?
- Do the condenser fan and indoor blower turn free without rubbing and are they tight on the shafts?
- Has the indoor blower speed been determined and the proper speed been set? To adjust the fan, see the Indoor Fan Motor Speed Tap Setting section.
- Has all work been done in accordance with applicable local and national codes?
- Are all covers and access panels in place to prevent air loss and safety hazards?

Starting the Unit in Cooling Mode

Note: See the section on Sequence of Operation for a description of the cooling operating sequence.

To start the unit in the cooling mode, set the thermostat system switch to COOL and move the thermostat COOL indicator to a setting below room temperature. The condenser fan motor, compressor and evaporator fan motor will operate automatically.

Operating Pressure Checks

After the unit has operated in the cooling mode for a short period of time, install pressure gauges on the gauge ports of the discharge and suction line valves (behind the Compressor access panel). Check the suction and discharge pressures and compare them to

the normal operating pressures provided in the unit's SERVICE FACTS.

Note: Do not use the PRESSURE CURVES from the unit's SERVICE FACTS to determine the unit refrigerant charge. The correct charge is shown on the unit nameplate. To charge the system accurately, weigh in the charge according to the unit nameplate and check subcooling against the Subcooling Charging Table in the SERVICE FACTS.

Voltage Check

With the compressor operating, check the line voltage at the unit (contactor is located behind the Control/Heat access panel). The voltage should be within the range shown on the unit nameplate. If low voltage is encountered, check the size and length of the supply line from the main disconnect to the unit. The line may be undersized for the length of the run.

Cooling Shut Down

At the thermostat, place the system selector to the OFF position or reset the thermostat to a setting above room temperature.

Important: De-energize the main power disconnect ONLY when servicing the unit. Power may be required to keep the heat pump compressor warm and to boil off refrigerant in the compressor.

Starting the Unit in Heating Mode

Note: See the section on Sequence of Operation for a description of the heat pump heating operating sequence.

These units are equipped with a solid-state ignition control that lights the burners each time the thermostat calls for heat. The burners are extinguished during the OFF cycle. To start the gas heating section of the unit:

1. Check that all grills and registers are open and all unit access panels are closed before start-up.
2. Purge the gas supply line of air by opening the union ahead (upstream) of the unit. When the odor of gas is detected, retighten the union and wait five (5) minutes before proceeding.
3. Be sure the thermostat is at its lowest setting and the power to the unit is off.
 - a. Turn the main shut-off valve on the gas supply line to ON.
 - b. Turn the thermostat to the highest setting in the heating cycle.
4. Be sure the burner compartment access panel is in place.

- a. Turn on the electrical power to the unit.
 - b. Turn the thermostat to the highest setting in the heating cycle.
5. As the thermostat calls for heat, the system cycles as follows:
- a. The combustion blower is energized.
 - b. The pressure switch is closed.
 - c. The gas valve opens and the ignitor lights the burner.
 - d. Cycle the thermostat on and off a few times to check out the control system and burner operation characteristics.

Note: For manifold pressures and orifice sizes for gas with other BTU ratings, contact the local gas utility. Manifold pressure should be 3.5 inches w.c. (+0.1). Input must **not** exceed the value shown on the rating plate.

- e. With the burner operating, check the manifold pressure with a manometer.
6. Do not exceed recommended pressures. If the manifold pressure needs adjustment, refer to Manifold Pressure Check and Adjust in the Maintenance section. With the burners operating, check the manifold pressure with a manometer.
7. If necessary, adjust the unit to obtain an air temperature rise with that specified on the unit nameplate. To adjust, refer to the Indoor Fan Motor Speed Adjustment in the Maintenance section.

Note: Blue smoke produced by the heat exchanger during the initial burner firing is caused by a thin film of oil on the surface of the heat exchanger. This oil will burn off quickly.

8. Set the thermostat at the desired temperature setting and the unit will function automatically.

Final Installation Checklist

- Does the unit run and operate as described in the section on "Sequence of Operation" in response to the room thermostat?
- Are the condenser fan and indoor blower operating correctly with proper rotation and without undue noise?
- Is the compressor operating correctly and has the system been checked with a charging chart?
- Has the voltage and running current been checked to determine if it is within limits?
- Has the thermostat been checked for calibration and the air discharge grilles adjusted to balance the system?
- Has the ductwork been checked for air leaks and condensation?
- Has the furnace manifold pressure been checked and adjusted if necessary?
- Has the heating air temperature rise been checked?
- Has the unit been checked for tubing and sheet metal rattles? Are there any other unusual noises to be checked?
- Are all covers and panels in place and properly fastened?
- Has the owner been instructed on the proper operation and maintenance of the unit? Be sure to leave this manual with the owner.

Sequence of Operation

General

Operation of the system cooling (and optional heating) cycles is controlled by the setting of the system switch on the room thermostat. Once the system switch is placed either in the "HEAT" or "COOL" position, unit operation is automatic. A fan switch on the thermostat also provides for continuous operation of the evaporator fan when desired. The fan switch "ON" position provides continuous operation while the "AUTO" position provides operation during the heating or cooling cycles.

Heating Cycle

Thermostat call for heat

(R) and (W) thermostat contacts close signaling the control module (IGN) to run its self-check routine. After the control has verified that the pressure switch (PS) contacts are open, the limit switch (TCO) contacts are closed, and the flame rollout (RO) switch is closed, the induced draft blower (CFM) will be energized.

After the induced draft blower (CFM) has come up to speed, the control will verify that the pressure switch (PS) contacts are closed and run the induced draft blower for a 20 second pre-purge. The gas valve (GV) is energized to permit gas flow and the spark ignitor (IP) is energized. The flame detector (FD) confirms that ignition has been achieved within the 7 second trial period.

As the flame detector confirms that ignition has been achieved the delay to indoor fan on period begins timing and after approximately 45 seconds, the indoor blower motor (IDM) will be energized and will continue to run during the heating cycle

Thermostat satisfied:

(R) and (W) contacts open signaling the control module to close the gas valve and de-energize the induced draft blower after approximately 5 seconds post-purge. The indoor blower motor will continue to operate at the current speed for 60 or 90 seconds (field selectable) after the flames are extinguished.

Cooling Cycle

With the room thermostat system switch in the "COOLING" position and the fan switch in the "AUTO" position, the compressor contactor (CC) and the indoor fan motor (IDM) are energized.

The energized compressor contactor (CC) completes the circuit to the compressor (CPR) and a secondary circuit to the outdoor fan motor (ODM). If the compressor safety controls are closed, the compressor (CPR) will operate with the outdoor fan motor (ODM). The indoor fan motor (IDM) will operate. The thermostat will continue to cycle the compressor and fans to maintain the desired temperature.

With the thermostat fan switch in the "ON" position, the indoor fan motor (IDM) will continue to run at constant circulation of 40 – 50% airflow of selected tap regardless of compressor and condenser fan operation.

Safety Sequences

This product is equipped with safety devices to protect against abnormal conditions.

The temperature limit switch (TCO) is located on the blower barrier, and can be accessed through the blower compartment. This automatic reset device protects against excessive leaving air temperature. If this device opens, the gas valve is immediately closed and will not permit operation until the limit switch closes.

The rollout switch (RO) is located in the gas compartment near the inlet of the burners. This is a manual reset device designed to protect against any form of flame rollout. If this device is opened the gas valve is immediately de-energized and the control (IGN) will lockout the system. The rollout switch (RO) must be reset before operation is allowed to continue.

The pressure switch (PS) is located in the upper right side of the gas compartment. This automatic device assures adequate combustion air pressure. If pressure against the induced draft blower outlet becomes excessive, the pressure switch will react and shut off the gas valve, until acceptable combustion pressure is again available.

If the control (IGN) does not sense flame within the first trial for ignition period, the gas valve will be de-energized. The control (IGN) will initiate a 60 seconds interpurge. Following the interpurge, the control will perform a second ignition attempt. If the second try is not successful, the control will start another 60 second interpurge. After the interpurge, a third attempt will be tried. If the third try is not successful, the control will lock out.

If loss of flame occurs during a heating cycle, the control (IGN) will close the gas valve and cycle through the ignition trial as stated above.

If control lock out occurs, the control (IGN) will retry a complete ignition sequence in 1 hour.

The control (IGN) can be reset by removing power to the unit or by turning the thermostat from "on" to "off" for approximately three seconds, then back "on".

Service Maintenance

Service maintenance should be performed by qualified service personnel.

Cooling Season

To keep the unit operating safely and efficiently, the manufacturer recommends that a qualified service

technician check the entire system at least once each year or more often if needed. The service technician should examine these areas of the unit:

- filters (for cleaning or replacement)
- motors and drive system components
- economizer gaskets (for possible replacement)
- safety controls (for mechanical cleaning)
- electrical components and wiring (for possible replacement and connection tightness)
- condensate drain (for proper sealing and cleaning)
- unit duct connections (to see that they are physically sound and sealed to the unit casing)
- unit mounting support (for structural integrity)
- the unit (for obvious unit deterioration)

Heating Season

Complete the following unit inspections and service routines described at the beginning of each heating season.

- Visually inspect the unit to ensure that the airflow required for combustion and condenser coil is not obstructed from the unit.
- Inspect the control panel wiring to verify that all electrical connections are tight and that the wire insulation is intact.
- Check the operation of the gas ignition system as follows: Turn off the gas supply with the unit operating to verify that the gas valve closes and that a re-ignition cycle is initiated by the unit.
- Visually inspect the inside of the burners and the burner ports for deposit buildup and corrosion. Wipe and brush the inside of the burner and the burner ports and then clean with a dry cloth. If the deposit buildup or corrosion is excessive, replace the burners.

Flue Hood and Combustion Blower Cleaning

Never use combustible cleaning fluids on any part of the furnace.

Before each heating season, the flue should be inspected for signs of flaking rust and soot deposits.

Dirty flues should be cleaned by qualified service personnel ONLY using the following procedure:

1. Turn the comfort control to **OFF**. Turn the main power disconnect **OFF**. Turn the manual gas valve **OFF**.
2. Remove the flue hood and the CONTROL/HEAT access panel.

3. Remove the combustion blower assembly from the flue box. Remove the flue box and the flue restrictors.
4. Remove all wires from the gas valve while carefully noting their locations.
5. Disconnect the gas supply line from the valve.
6. Remove the manifold retaining screws and pull the burner-manifold assembly from the heat exchanger.
7. Remove the inlet turbulators being careful not to break or damage them.
8. Wipe the flue box and flue baffles clean with a clean, dry cloth.
9. Replace all gaskets with new ones.
10. Replace all damaged or broken turbulators with new ones.
11. Reassemble the unit by reversing Steps 2 through 7 above. Take care that all gaskets seat properly.
12. Check all wires for correct installation by referring to the unit's electrical wiring diagram in the SERVICE FACTS.
13. Leak test all gas line connections with a soap and water solution or the equivalent.
14. Re-install the CONTROL/HEAT access panels and the flue hood.
15. Visually inspect the unit to ensure that the airflow opening for combustion is not obstructed.
16. Follow "[Step 5 – Unit Startup](#)," p. 26 to place the unit back in service.

Indoor Fan Motor (IDM) Speed Tap Setting

The 208/230 units are factory set to medium speed.

208/230 Volt Motor Tap Settings ()

High speed setting: On the IGN board:

1. Connect the "RD" wire to the "PARK" terminal.
2. Connect the (IDM) PR wire to the "BLOWER LOAD" terminal.

Low speed setting: On the IGN board:

1. Connect the "RD" wire to the "BLOWER LOAD" terminal.
2. Connect the (IDM) PR wire to the "PARK" terminal.

Sequence of Operation

Figure 17. 208/230 Volt Speed Taps

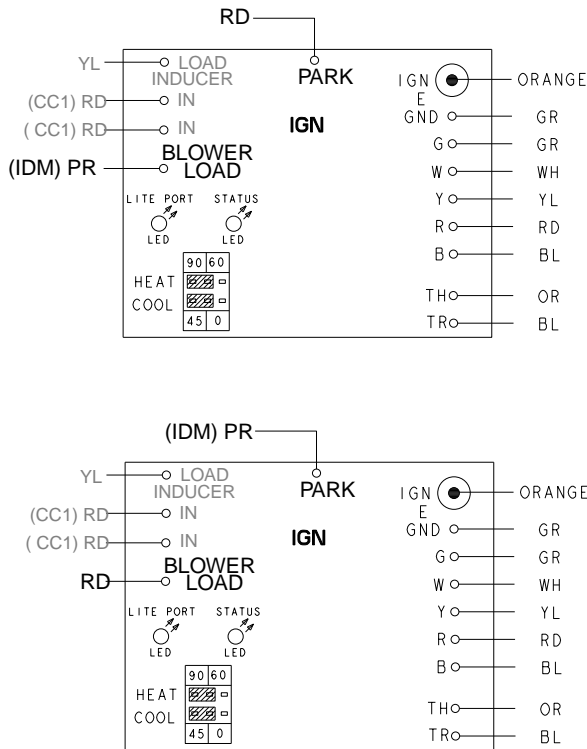

Table 13. IGN LED Diagnostic Indicators

Status LED		Liteport LED	
Steady OFF	Check Power or Failed Board	2 Flashes	System Lockout: Failed to detect or sustain flame
Slow Flash Rate	Normal, No Call for Heat	3 Flashes	Pressure switch problem detected
Fast Flash Rate	Not used	4 Flashes	High Limit switch protection device open
Steady ON	Normal, No Call for Heat	5 Flashes	Flame sensed and gas valve <u>not</u> energized or flame sensed and no "W" signal.
		6 Flashes	Flame Rollout Switch open
		7 Flashes	Thermostat miswired; W1 & W2

Fast Flash Rate: The LED will flash on for 1/4 second and off for 1/4 second.
Slow Flash Rate: The LED will flash on for 3/4 second, then off for 1/4 second.
 The pause between groups of fast flashes is 3 seconds.

About Trane and American Standard Heating and Air Conditioning

Trane and American Standard create comfortable, energy efficient indoor environments for residential applications. For more information, please visit www.trane.com or www.americanstandardair.com.



The AHRI Certified mark indicates company participation in the AHRI Certification program. For verification of individual certified products, go to ahridirectory.org.

The manufacturer has a policy of continuous data improvement and it reserves the right to change design and specifications without notice. We are committed to using environmentally conscious print practices.