

Installer's Guide

LP Conversion Kit for Single/Two Stage Gas

***YC** 1.5 – 5 Ton**

***DC** 2 – 5 Ton**

BAYLPKT100

BAYLPKT101

BAYLPKT102

*Note: * indicates an alpha character.*

SAFETY WARNING

Only qualified personnel should install and service the equipment. The installation, starting up, and servicing of heating, ventilating, and air-conditioning equipment can be hazardous and requires specific knowledge and training. Improperly installed, adjusted or altered equipment by an unqualified person could result in death or serious injury. When working on the equipment, observe all precautions in the literature and on the tags, stickers, and labels that are attached to the equipment.

SAFETY SECTION

Important: This document contains a wiring diagram, a parts list, and service information. This is customer property and is to remain with this unit. Please return to service information pack upon completion of work.

⚠ WARNING

HAZARDOUS VOLTAGE!

Failure to follow this Warning could result in property damage, severe personal injury, or death.

Disconnect all electric power, including remote disconnects before servicing. Follow proper lockout/tagout procedures to ensure the power cannot be inadvertently energized.

⚠ WARNING

SAFETY AND ELECTRICAL HAZARD!

Failure to follow this Warning could result in property damage, severe personal injury, or death.

These servicing instructions are for use by qualified personnel only. To reduce the risk of electrical shock, do not perform any servicing other than that contained in these operating instructions unless you are qualified to do so.

⚠ CAUTION

GROUNDING REQUIRED!

Failure to inspect or use proper service tools may result in equipment damage or personal injury. Reconnect all grounding devices. All parts of this product that are capable of conducting electrical current are grounded. If grounding wires, screws, straps, clips, nuts, or washers used to complete a path to ground are removed for service, they must be returned to their original position and properly fastened.

⚠ WARNING

SAFETY HAZARD!

Operating the unit without the access panels properly installed may result in severe personal injury or death.

Do not operate the unit without the evaporator fan access panel or evaporator coil access panel in place.

⚠ WARNING

WARNING!

This product can expose you to chemicals including lead, which are known to the State of California to cause cancer and birth defects or other reproductive harm. For more information go to www.P65Warnings.ca.gov.

Important: Wear appropriate gloves, arm sleeve protectors and eye protection when servicing or maintaining this equipment.

Important: Air filters and media wheels or plates shall meet the test requirements in UL 900.

Table of Contents

GENERAL INFORMATION 4
INSPECTION 4

CONVERSION PROCEDURE..... 4

GENERAL INFORMATION

These instructions describe converting single/two stage packaged gas/electric models *YC* and dual fuel models *DCY/*DCL from natural gas to LP gas.

Conversion from natural gas to LP gas is a critical procedure; therefore, these **INSTRUCTIONS MUST BE FOLLOWED CLOSELY**. The conversion kit shall be installed by a qualified service agency.

INSPECTION

1. Unpack all components of the LP conversion kit
2. Check the kit for damage. Report promptly to the carrier any damage found to the kit.
3. Check to be sure that the package contains the parts listed in Table 1. Any missing components should be reported to your supplier at once and replaced with authorized components only.

Table 1. Orifice Kits

Model	Orifice		LP Springs	Manifold Pressure		
	Qty	Size		Single Stage Models	2 – Stage Models	
					1st Stage	2nd Stage
BAYLPKT100 (All 40k, 115k, and 120k models)	3	#49	2 (a)	10.0	5.6	10.0
BAYLPKT101 (All 60k, 64k, 90k and 96k models)	3	#52	2 (a)	10.4	5.8	10.4
BAYLPKT102 (All 70k, and 75k models)	2	#50	2 (a)	10.4	5.8	10.4

(a) Use 1 spring for single stage models

CONVERSION PROCEDURE

1. Set the thermostat to OFF
2. Shut off gas supply to the unit.
3. Open the unit's electrical disconnect switch
4. Remove the Controls/Heat access panel.
5. Remove the manifold from the burner bracket four (4) screws.
6. Remove the natural gas orifices from the manifold. See Figure 1.
7. Install LP gas orifices in manifold
8. At the gas regulator, remove the natural gas spring located under the gas valve's regulator adjustment screw.

- a. For single stage units with White-Rodgers model 36G gas valve only: remove the cap screw, then remove plastic adjusting screw, and lastly the regulator spring. Replace regulator spring with one of the springs from the kit.
 - b. For two stage units with White-Rodgers model 36G gas valve only: remove low fire cap screw, then plastic adjusting screw, and lastly the low fire regulator spring. Replace low fire regulator spring with one of the springs from the kit. Repeat this procedure for replacing the high fire regulator spring with the other spring from the kit.
9. Reverse the disassembly procedure and secure all components in their respective positions
 10. Attach the "LP" nameplate supplied with this kit adjacent to the unit nameplate and apply the conversion label to the gas valve.
 11. Check all piping joints and electrical connections for tightness
 12. Turn on the gas supply to the unit
 13. Measure the gas pressure. The incoming supply gas pressure should be 11" to 13" W.C.
 14. Check for leaks at all joints with a soap solution.

Note: Contact the LP gas supply company if the supply pressure is different than the supply pressure indicated on the unit nameplate.

15. Restore power to unit.
16. Place the thermostat selector switch to the HEAT position and adjust the set point indicator to its highest setting. The burners should light.
17. Refer to rating nameplate for proper input. Adjust the unit manifold pressure to the values shown in [Table 1, p. 4](#) (Refer to *YCC/YCX, *YCY, *DCY, *DCL, *YCZ, or *DCZ Installer's Guide for proper adjustment instructions and input calculations). High-fire regulation should be adjusted first, followed by low-fire adjustment.
18. Inspect burner flames. Flame should be soft, stable, and blue. Flames should not lift off of burners or have significant yellow tipping.
19. Replace the access panel.
20. Refer to *YCC/YCX, *YCY, *DCY, or *DCL Installer's Guide to verify proper unit sequence of operation.
21. At altitudes above 2000 feet derate application 4% per 1000 feet.

**NATURAL TO LP CONVERSION
TROUBLESHOOTING FOR TWO STAGE
UNITS ONLY**

Valve does not respond to adjustment

Make sure that furnace is in proper mode for adjustment, i.e., low-fire mode for low-fire adjustment, high-fire mode for high-fire adjustment

Low-fire does not respond to adjustment (in low-fire mode)

Ensure that low-fire screw is being adjusted, and that actual high-fire setting is currently greater than desired low-fire setting.

High-fire regulator must be converted and adjusted to new setting before low-fire regulator can be properly adjusted.

High-fire does not respond to adjustment (in high-fire mode)

Ensure that high-fire screw is being adjusted, and that valve is in high-fire mode by checking for proper current to 2-stage solenoid (at HI terminal).

Low-fire adjustment should have no effect when in high-fire mode.

Valve only responds to high-fire adjustment (in low-fire mode)

This indicates that actual low-fire adjustment is greater than the current high-fire adjustment. Ensure that LP spring is in high-fire regulator. Increase high-fire adjustment until valve no longer responds, then adjust low-fire setting.

Figure 1. BURNER AND VALVE

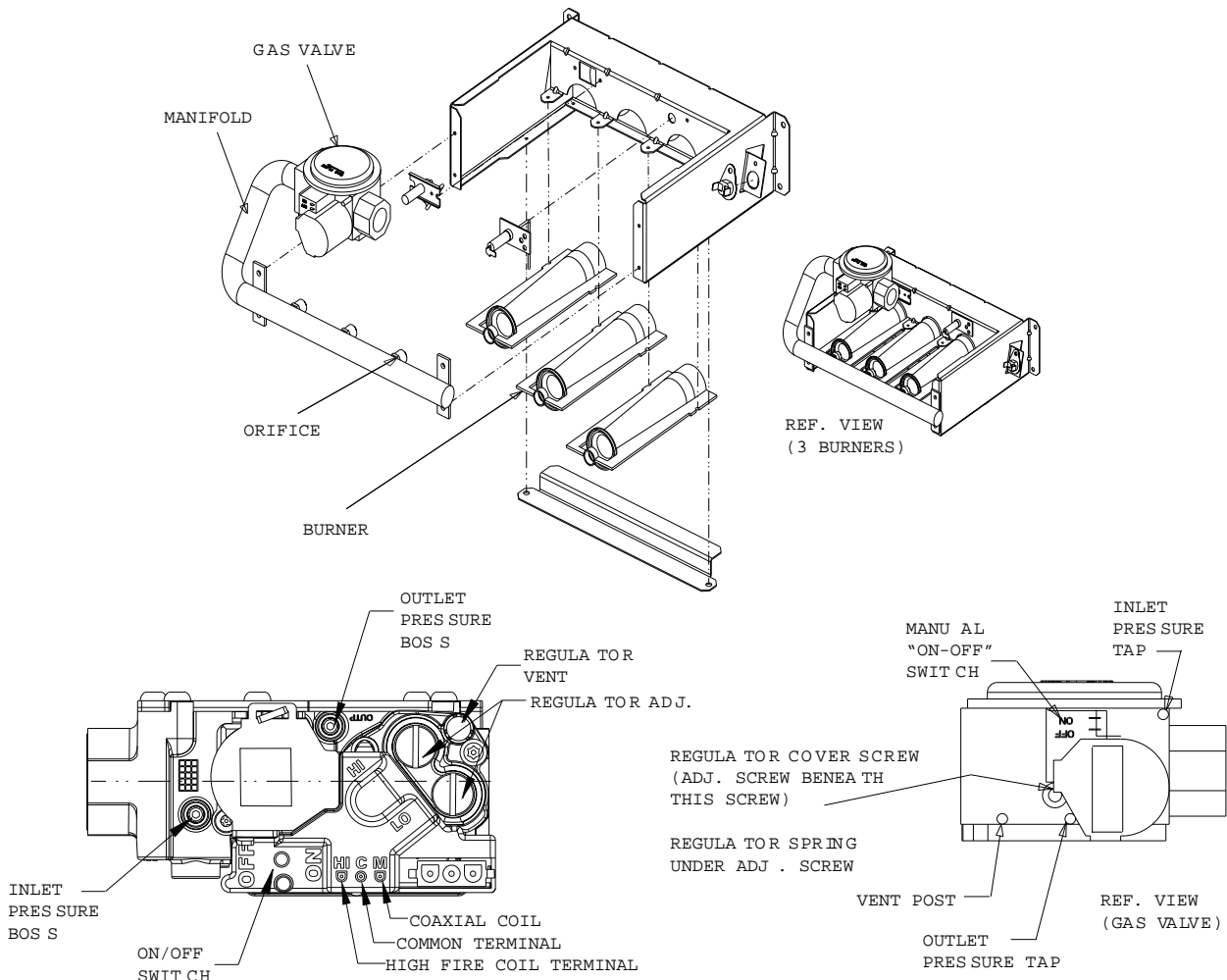

About Trane and American Standard Heating and Air Conditioning

Trane and American Standard create comfortable, energy efficient indoor environments for residential applications. For more information, please visit www.trane.com or www.americanstandardair.com.

The manufacturer has a policy of continuous data improvement and it reserves the right to change design and specifications without notice. We are committed to using environmentally conscious print practices.