

## Automatic Humidifier Control ECONTH01AAUTOA

READ COMPLETE INSTALLATION INSTRUCTIONS AND TEMPLATE BEFORE STARTING.

**⚠ WARNING: HAZARDOUS VOLTAGE – DISCONNECT POWER BEFORE INSTALLING OR SERVICING**

ALL phases of this installation must comply with NATIONAL, STATE AND LOCAL CODES

**IMPORTANT – This Document is customer property and is to remain with this unit. Please return to service information pack upon completion of work.**

THIS INFORMATION IS FOR USE BY INDIVIDUALS HAVING ADEQUATE BACKGROUNDS OF ELECTRICAL AND MECHANICAL EXPERIENCE. ANY ATTEMPT TO REPAIR A CENTRAL AIR CONDITIONING PRODUCT OR ACCESSORY HUMIDIFIER OR HUMIDIFIER CONTROL MAY RESULT IN PERSONAL INJURY AND/OR PROPERTY DAMAGE. THE MANUFACTURER OR SELLER CANNOT BE RESPONSIBLE FOR THE INTERPRETATION OF THIS INFORMATION, NOR CAN IT ASSUME ANY LIABILITY IN CONNECTION WITH ITS USE.

These instructions do not cover all variations in systems or provide for every possible contingency. Should further information be desired or particular problems arise which are not covered sufficiently by this manual, contact your local distributor or the manufacturer as listed on the humidifier nameplate.

**THESE INSTALLATION INSTRUCTIONS ARE FOR THE AUTOMATIC HUMIDIFIER CONTROL ONLY!**  
For Humidifier installation, follow Humidifier Installation Instructions.

### ⚠ WARNING

- 120 volts may cause serious injury from electrical shock. Disconnect electrical power to the furnace before starting installation.
- Sharp edges may cause serious injury from cuts. Use care when cutting plenum openings and handling ductwork. Use personal protective equipment when installing or servicing HVAC equipment.

### ⚠ CAUTION

- Do not set humidity higher than recommended. Property damage may result.
- Do not set humidity up to recommended levels if there is condensation on the inside of windows of any unheated living space. Property damage may result.
- Do not mount Humidifier Control on supply plenum or duct. The Control will not withstand supply temperatures.
- When installing Humidifier Control on downflow furnaces, ensure blower continues to run after a heat call is satisfied to eliminate high temperatures from damaging the Humidifier Control.
- Do not mount Humidifier Control downstream of the bypass outlet. The Control will not operate correctly due to false humidity readings.
- Set the Bypass/Power mode switch in the proper position, or damage to the Humidifier Control could result (see Step 3).

### STEP 1: Unpack the Humidifier Control Carton

Make sure all components are present (see Figure A):

- A. Humidifier Control
- B. Outdoor Temperature Sensor
- C. Manual Mode Label
- D. Manual Mode Resistor Case

**Note:** The Control may be installed in automatic or manual mode.

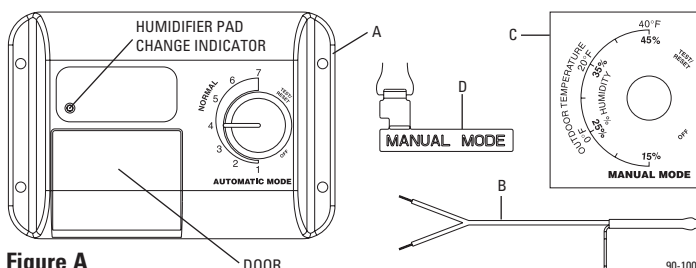

Figure A

### STEP 2: Disassemble the Humidifier Control

Remove door from the Humidifier Control by pulling the bottom of the door straight out.

### STEP 3: Check the Mode Switch

With the door removed, notice the switch labeled BYPASS and POWER (partially covered by the enclosure). Make sure the switch is correctly set for the type of humidifier being installed or damage to the Humidifier Control could result (see Figure B).

### STEP 4: Check the Change Humidifier Pad Indicator Setting

This setting controls the indicator light interval, reminding you to change your Humidifier Pad. If your Control came with a humidifier, the Control is pre-set at position "C". If the installation site has a 3-month or shorter heating season or very hard water, you may want to adjust the setting (see Figure B). The Control must be energized to reset the Humidifier Pad Indicator.

Use the "OFF" setting to turn the Humidifier Pad Change indicator OFF.

Use setting "A" for very hard water conditions in any location. Humidifier Pad Change indicator LED light will activate after 75 hours of solenoid valve operation.

Use setting "B" for winters in the South. Humidifier Pad Change indicator LED light will activate after 300 hours of solenoid valve operation.

Use setting "C" for winters in the Midwest and Eastern United States. Humidifier Pad Change indicator LED light will activate after 600 hours of solenoid valve operation.

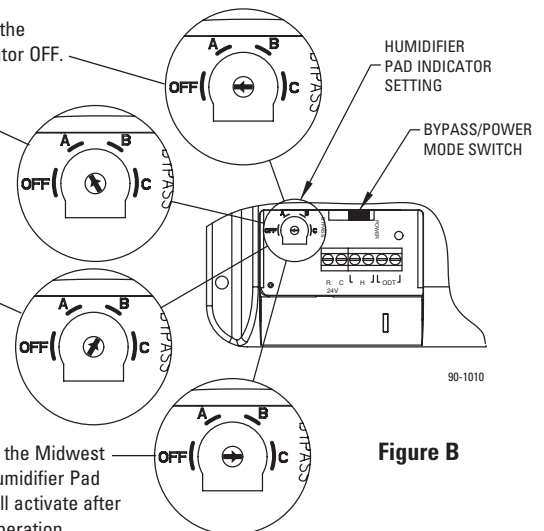

Figure B

## STEP 5: Determine Location for Humidifier Control and Mount It

Humidifier Control must be mounted in the Return Duct. For proper operation, the Humidifier Control must be at least 6 inches upstream of any of the following:

- Humidifier
- Humidifier Bypass Ductwork (if applicable)
- Fresh Air Intake Ductwork (if applicable) (see **Figure C**)

After location for Control is selected, use the perforated Humidifier Control template (attached to these instructions) to mark the duct opening and cut it. Use 4 sheet metal screws (not provided) to mount the Humidifier Control in the duct opening and **make sure Humidifier Control is sealed tightly to duct.**

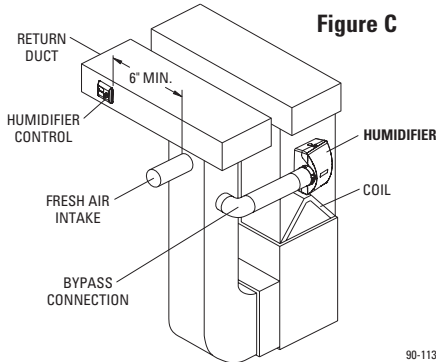

90-1137

### CAUTION

Do not mount control on supply air plenum or duct. Failure to follow this caution may cause property damage.

## STEP 6: Determine Location for Outdoor Temperature Sensor

The location of the Outdoor Temperature Sensor must meet these three requirements:

1. Must be mounted on North, East or West side of house out of direct sunlight
2. **Must be at least 3 feet from all exhaust vents**
3. Must be above expected snow line (See **Figure D**)

Incorrect humidity levels will result if these requirements are not met.

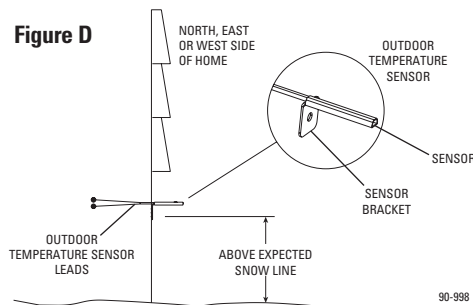

90-998

## STEP 7: Locate Existing Access Hole to Outside

A convenient way to get the Sensor wire outside is to make use of unused wires running to the A/C condensing unit (if applicable). Other ways are to use existing holes for Cable TV lines, telephone lines, A/C lines, etc. Read all equipment instructions beforehand for possible conflicts and warnings.

## STEP 8: Alternate Location for Outdoor Temperature Sensor

The Sensor can also be mounted in the center of either:

- 2 inch PVC fresh air intake pipe for the furnace
- OR**
- 6 inch fresh air intake duct. Mount the sensor with a #8 galvanized screw.

**In both cases, the Sensor must be no more than 3 feet from the outside wall. See Figure E.**

If it is not feasible to use the Outdoor Temperature Sensor in any of the ways described, the Humidifier Control can be installed for Manual Operation. See box "Installing the Humidifier Control for Manual Operation" and **Figure G** for details.

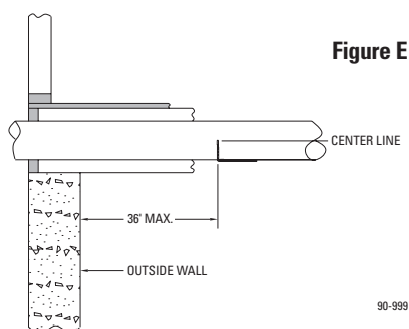

90-999

## STEP 9: Route the Wire from Control to Sensor

Run a separate 18 ga. control wire to the outdoor temperature sensor. Sensor is not affected by lead length. In either case, do not run outdoor temperature sensor alongside wires carrying high voltage (120 VAC or higher). Secure the sensor bracket with a #8 galvanized screw.

## STEP 10: Attach Sensor Wire to Humidifier Control

Strip wire 1/4 inch, and insert the wires from the Sensor into the terminals labeled "ODT" on the Humidifier Control. See **Figure F** for location of terminals.

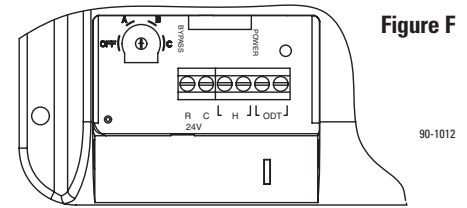

90-1012

### Installing the Humidifier Control for Manual Operation

If it is not feasible to use the Outdoor Temperature Sensor, the Humidifier Control can be operated in Manual Mode.

1. Connect the Manual Mode Resistor Case wires to the terminals labeled "ODT" on the Humidifier Control.
2. Snap the Manual Mode Resistor Case into the slot provided so that Resistor Case sticks out from the bottom edge of the base.
3. Remove the control knob and apply the Manual Mode label to the cover, aligning the sticker and knob holes. Re-install the knob.

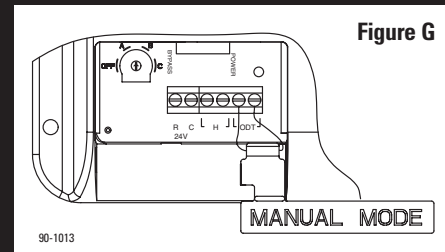

90-1013

## STEP 11: Determine Power Source for Humidifier Control

Determine where you will get 24 VAC to power the Humidifier Control (see options below).

### OPTION 1: FURNACES WITH ACCESSORY TERMINALS.

If the accessory terminals provide:

- 24 VAC: Wire these directly to the "R" and "C" terminals on the Humidifier Control.
- 120 VAC: Wire to a 24 VAC transformer, which in turn connects to the "R" and "C" terminals on the Humidifier Control.

### OPTION 2: EXTERNAL 24 VAC TRANSFORMER:

Wire into a power source other than the furnace blower circuit. The transformer can be powered off the 120 VAC line at the junction box before it enters the furnace. The 24 volt side of the transformer is connected to the "R" and "C" terminals on the Humidifier Control.

In either case, the voltage to the Humidifier Control must be between 22 VAC and 30 VAC. Run a separate 18 ga. wire from a 24-volt supply to the humidifier control.

### NOTES:

- The Humidifier Control will operate properly with either a switched or continuous power source.
- Whether using ACCESSORY TERMINALS OR an EXTERNAL TRANSFORMER, the minimum VA required is: 2.0 VA for Power Humidifiers; or 10.0 VA for Bypass Humidifiers.
- When power is connected for the first time, the red and green LEDs will light momentarily.

## STEP 12: Wiring

See **Diagrams A-D** for wiring options.

## FAN POWERED HUMIDIFIER WIRING DIAGRAM

### Diagram A

FOR HUMIDIFIER OPERATION DURING "HEAT CALL" ONLY

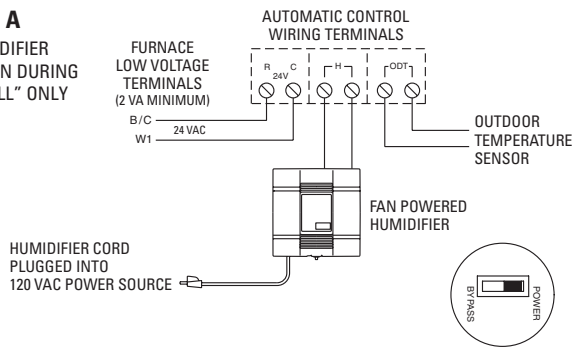

### Diagram B

FOR HUMIDIFIER OPERATION WHEN BLOWER IS ENERGIZED

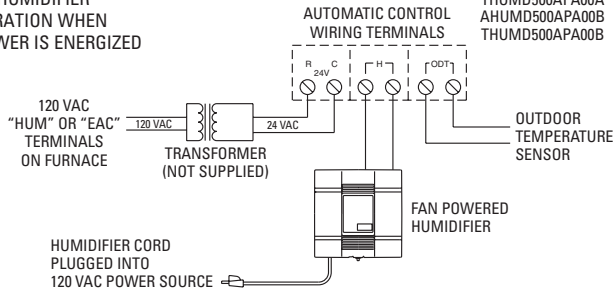

**SWITCH POSITION MODELS**  
 AHUMD500APA00A  
 THUMD500APA00A  
 AHUMD500APA00B  
 THUMD500APA00B

90-1048

## BYPASS HUMIDIFIER WIRING DIAGRAM

### Diagram C

FOR HUMIDIFIER OPERATION DURING "HEAT CALL" ONLY

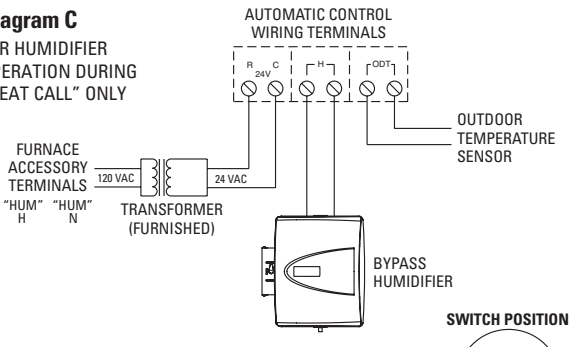

### Diagram D

FOR HUMIDIFIER OPERATION WHEN BLOWER IS ENERGIZED

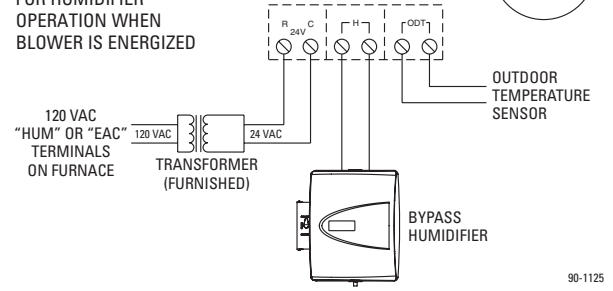

90-1125

## System Checkout

- For system Test/Reset, be sure that 24 VAC is applied to the "R" and "C" terminals of Humidifier Control.
- Snap the door back onto the Humidifier Control Base.
- Activate furnace blower and be sure thermostat is calling for heat.
- Rotate the control knob of Humidifier Control clockwise to the "Test/Reset" position. When the knob is set in the "Test/Reset" position, the green "Change Humidifier Pad" light will blink. Make sure the knob is not left in the "Test/Reset" position when the installation is done. Rotating knob to test position resets the humidifier pad change timer to zero. The Control must be energized to reset the Humidifier Pad Indicator.
- If all is set up properly, you should be able to hear the solenoid valve click open. In "Test/Reset" mode, the Humidifier will operate for 1 minute.
- If the humidifier does not activate with the Humidifier Control in the "Test/Reset" position, refer to troubleshooting guide.
- Setting the Humidifier Control:
  - If home is occupied, set Humidifier Control to "Normal" (For Manual Operation, set to 35%)
  - If home is vacant, set Humidifier Control to "Off"
- Inform homeowner to refer to the Use and Care manual for the initial adjustment period.
- Make sure the Red Diagnostic Light is not lit. If the Red Diagnostic Light is lit, re-check your wiring.

## Humidifier Control Troubleshooting Guide

Applies to both Automatic and Manual Operation unless indicated otherwise.

### SYMPTOM TROUBLESHOOTING PROCEDURE

- Humidifier does not operate in "Test" mode
- Make sure furnace blower is operating and thermostat is calling for heat.
  - Make sure the Outdoor Temperature Sensor is connected to the "ODT" terminals of the control. (For Manual Operation, make sure Manual Mode Resistor Case is in place.)

- Check wiring diagram for correct Humidifier Control installation.
- Check voltage at Humidifier Control "R" and "C" terminals. Voltage should be 22 VAC minimum – 30 VAC maximum.
- Check Current Sensing Relay (if used) for correct installation (see Current Sensing Relay Installer's Guide. The Guide ships with the relay or may be obtained from your local distributor). Do not use Current Sensing Relay in transformer circuit or "R" and "C" circuit of Humidifier Control. Current Sensing Relay is to be used in the "H" circuit only.
- In "Test" mode, humidifier will operate for 1 minute only. DO NOT LEAVE IN TEST MODE AS HUMIDIFIER WILL NOT OPERATE
- Make sure saddle valve is open.

### HUMIDIFIER CONTROL TEMPLATE

#### ⚠ WARNING

Sharp edges on the opening may cause cuts. Use care when cutting the plenum opening and installing the Humidifier Control.

#### ⚠ CAUTION

- Do not mount Humidifier Control on supply plenum or duct. The Control will not withstand supply temperatures and will malfunction!
- When installing Humidifier Control on counterflow furnaces, ensure blower continues to run after a heat call is satisfied to eliminate high temperatures from damaging the Humidifier Control.
- Do not mount Humidifier Control downstream of the bypass outlet. The Control will not operate correctly due to false humidity readings.

- CUT OUT TEMPLATE ALONG EDGES.
- PLACE TEMPLATE ON THE RETURN PLENUM UPSTREAM OF (BEFORE) THE HUMIDIFIER CONNECTION.
- TRACE OUTSIDE EDGES OF TEMPLATE.
- REMOVE TEMPLATE AND ACCURATELY CUT PLENUM OPENING.
- USING 4 SHEET METAL SCREWS, INSTALL HUMIDIFIER CONTROL IN PLENUM OPENING.

# Humidifier Control Troubleshooting Guide

Applies to both Automatic and Manual Operation unless indicated otherwise.

## SYMPTOM

## TROUBLESHOOTING PROCEDURE

“Change Humidifier Pad” Indicator is lit.

- Call your installer to have your Humidifier Pad changed, or visit your installer to purchase a new Humidifier Pad. Follow the instructions on the Humidifier Pad box.

Humidifier operates only in “Test” mode

- If outdoor temperature is greater than 60°F or less than -30°F, the Humidifier Control will only operate in the “Test” mode. (For One Minute)
- If the humidity level in the home is higher than the knob setting, the Humidifier Control will not operate the Humidifier.
- Check the resistance of the sensor by removing the leads of the Outdoor Temperature Sensor from the terminals and measuring the resistance across the wires with an ohmmeter. Compare reading to outdoor temperature in **Table 1**. (For Manual Operation, verify that resistance across the leads of Manual Mode Resistor Case is between 44,000 and 48,000 ohms).
- Make sure the Outdoor Temperature Sensor is mounted completely outside the house on the North, East, or West side of the house and out of direct sunlight. (Automatic Mode Only)
- If Outdoor Temperature Sensor is mounted in fresh air intake duct, make sure the probe is no more than 36 inches from the outside wall. (Automatic Mode Only)
- Make sure the Outdoor Temperature Sensor is located at least 3 feet away from all exhaust vents. (Automatic Mode Only)

**TABLE 1**

Outdoor Temperature	Resistance kΩ
-30°F	230.6
-20°F	163.8
-10°F	117.6
0°F	85.4
10°F	62.6
20°F	46.3
30°F	34.6
40°F	26.1
50°F	19.9
60°F	15.3
70°F	11.9
80°F	9.4
90°F	7.4
100°F	5.9

Humidifier operates constantly

- If the humidity level in the home is less than the knob setting, the Humidifier Control will operate the Humidifier until the humidity level is higher than the knob setting.
- In the “Test” mode, verify unit will operate for approximately one minute.
- Check the resistance of the Outdoor Temperature Sensor as instructed above.
- Make sure the Outdoor Temperature Sensor is mounted completely outside the house on the North, East, or West side of the house and out of direct sunlight. (Automatic Mode Only).
- Rotate the Humidifier Control knob counterclockwise to the “Off” position, and observe whether the humidifier turns off. If the humidifier still operates in the “Off” position, perform the following:
  1. Check wiring diagram for correct Humidifier Control Installation.
  2. Remove wires from Humidifier Control’s “H” terminals. If Humidifier continues to operate, replace solenoid valve.

Humidifier or Humidifier Control “chatters” or clicks ON and OFF rapidly

- Check for steady 22 VAC – 30 VAC with voltmeter.
- Make sure Outdoor Temperature Sensor wiring is not run alongside wires carrying high voltage (120 VAC or higher). (Automatic Only)

Red Diagnostic Light is on (See **Figure H**)

- Check that the wiring is correct.
- Measure the resistance of the Outdoor Temperature Sensor by removing the leads from the terminal and measuring the resistance across the wires with an ohmmeter. Confirm the reading with the temperature in **Table 1**. (For Manual Operation, verify that the resistance across the leads of the Manual Mode Resistor Case is between 44,000 and 48,000 ohms).

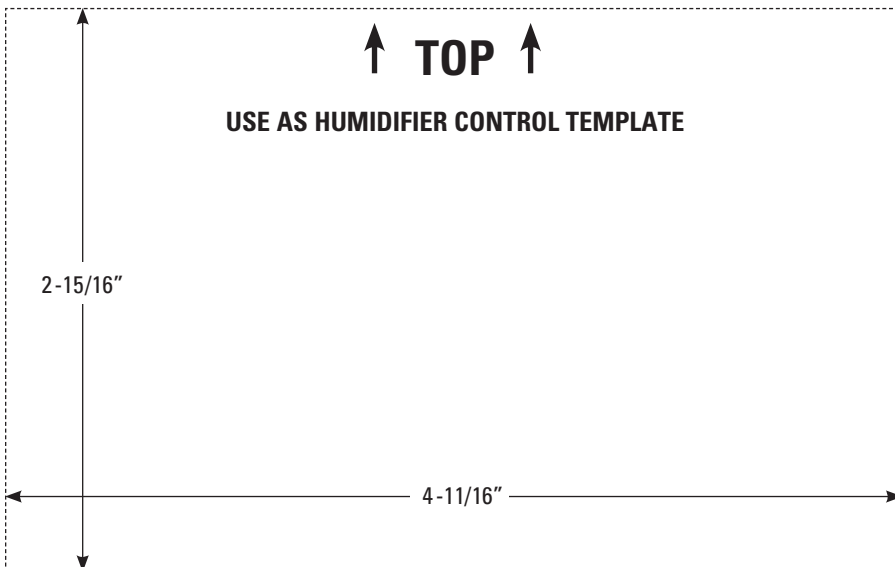
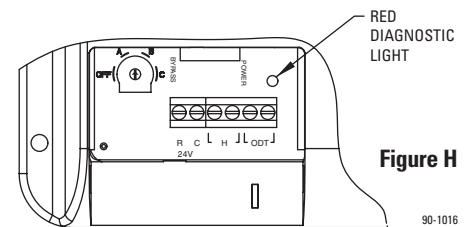

**HUMIDIFIER CONTROL TEMPLATE**

Trane  
6200 Troup Highway  
Tyler, TX 75711