

Installer's Guide

Upflow/Horizontal Left/Right Gas-Fired, Single Stage Induced Draft Furnaces with High Efficiency Blower Motor

Upflow, Horizontal Right/Left
(For use with Natural Gas only.)

Single Stage
L8X1B060U3XSAA
L8X1B080U4XSAA

*Note: This product complies with SJVAPCD 4905 and SCAQDMD 1111 with
NOx levels below 14 ng/J.*

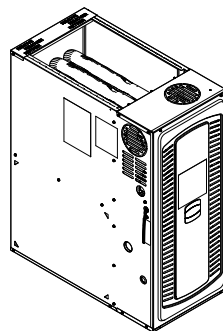

*Note: Graphics in this document are for
representation only. Actual model may
differ in appearance.*

▲ SAFETY WARNING

Only qualified personnel should install and service the equipment. The installation, starting up, and servicing of heating, ventilating, and air-conditioning equipment can be hazardous and requires specific knowledge and training. Improperly installed, adjusted or altered equipment by an unqualified person could result in death or serious injury. When working on the equipment, observe all precautions in the literature and on the tags, stickers, and labels that are attached to the equipment.

SAFETY SECTION NON-CONDENSING FURNACES

Important: — This document pack contains a wiring diagram and service information. This is customer property and is to remain with this unit. Please return to service information pack upon completion of work.

⚠ WARNING

FIRE OR EXPLOSION HAZARD!

Failure to follow safety warnings exactly could result in a fire or explosion causing property damage, personal injury or loss of life.

— Do not store or use gasoline or other flammable vapors and liquids in the vicinity of this or any other appliance. — **WHAT TO DO IF YOU SMELL GAS**

- Do not try to light any appliance.
 - Do not touch any electrical switch; do not use any phone in your building.
 - Immediately call your gas supplier from a neighbor's phone. Follow the gas supplier's instructions.
 - If you cannot reach your gas supplier, call the fire department.
- Installation and service must be performed by a qualified installer, service agency, or the gas supplier.

⚠ WARNING

EXPLOSION HAZARD!

Failure to follow this Warning could result in property damage, personal injury or death. Install a gas detecting warning device in case of a gas leak. **NOTE: The manufacturer of your furnace does not test any detectors and makes no representations regarding any brand or type of detector.**

⚠ WARNING

FIRE OR EXPLOSION HAZARD!

Failure to follow the safety warnings exactly could result in serious injury, death, or property damage.

Never test for gas leaks with an open flame. Use a commercially available soap solution made specifically for the detection of leaks to check all connections. A fire or explosion may result causing property damage, personal injury, or loss of life.

⚠ WARNING

ELECTRICAL SHOCK, FIRE, OR EXPLOSION HAZARD!

Failure to follow this Warning could result in dangerous operation, property damage, severe personal injury, or death.

Improper servicing could result in dangerous operation, property damage, severe personal injury, or death.

- Before servicing, disconnect all electrical power to furnace.
- When servicing controls, label all wires prior to disconnection. Reconnect wires correctly.
- Verify proper operation after servicing.

⚠ WARNING

CARBON MONOXIDE POISONING HAZARD!

Failure to follow this Warning could result in property damage, severe personal injury, or death.

To ensure furnace is vented properly, do not replace factory supplied venting components with field fabricated parts. Fabricating parts can result in damaged vents and components allowing carbon monoxide to escape the venting system.

⚠ WARNING

CARBON MONOXIDE HAZARD!

Failure to follow this Warning could result in property damage, severe personal injury, or death.

When replacing a furnace, ensure the venting system is adequate for the new furnace.

⚠ WARNING

FIRE HAZARD!

Failure to follow this Warning could result in property damage, severe personal injury, or death.

Do not install the furnace directly on carpeting, tile or other combustible material other than wood flooring. For vertical downflow applications, subbase (BAYBASE205) must be used between the furnace and combustible flooring. When the downflow furnace is installed vertically with a cased coil, a subbase is not required.

⚠ WARNING

WARNING!

This product can expose you to chemicals including lead, which are known to the State of California to cause cancer and birth defects or other reproductive harm.
For more information go to www.P65Warnings.ca.gov.

⚠ WARNING

ELECTRICAL SHOCK HAZARD!

Failure to follow this Warning could result in property damage, severe personal injury, or death.
Do not bypass the door switch or panel loop by any permanent means.

⚠ WARNING

ELECTRICAL SHOCK HAZARD!

Failure to follow this Warning could result in property damage, severe personal injury, or death.
Do not touch any components other than the SW1 button on the IFC during fault code recovery.

⚠ WARNING

FIRE OR EXPLOSION HAZARD!

Failure to follow this Warning could result in property damage, severe personal injury, or death.
Do NOT attempt to manually light the furnace.

⚠ WARNING

CARBON MONOXIDE POISONING HAZARD!

Failure to follow this Warning could result in property damage, severe personal injury, or death.
Follow the service and/or periodic maintenance instructions for the Furnace and venting system.

⚠ WARNING

CARBON MONOXIDE POISONING HAZARD!

Failure to follow this Warning could result in serious personal injury or death.
Make sure that the blower door is in place and not ajar. Dangerous fumes could escape an improperly secured door.

⚠ WARNING

ELECTRICAL SHOCK HAZARD!

Failure to follow this Warning could result in property damage, severe personal injury, or death.
Disconnect power to the unit before removing the blower door. Allow a minimum of 10 seconds for IFC power supply to discharge to 0 volts.

⚠ WARNING

SAFETY HAZARD!

Failure to follow this Warning could result in property damage, severe personal injury, or death.
These furnaces are not approved or intended for installation in manufactured (mobile) housing, trailers, or recreational vehicles.

⚠ WARNING

EXPLOSION HAZARD!

Failure to follow this Warning could result in property damage, severe personal injury, or death.
In the event that electrical, fuel, or mechanical failures occur, shut gas supply off at the manual gas valve located on the supply gas piping coming into the furnace before turning off the electrical power to the furnace. Contact the service agency designated by your dealer.

⚠ WARNING

EXPLOSION HAZARD!

Failure to follow this Warning could result in property damage, serious personal injury, or death.
Do not store combustible materials, gasoline, or other flammable vapors or liquids near the unit.

⚠ WARNING

SAFETY HAZARD!

Failure to follow this Warning could result in property damage, severe personal injury, or death.
Do not use semi-rigid metallic gas connectors (flexible gas lines) within the furnace cabinet.

⚠ WARNING

INSTALLATION WARNING — HIGH VOLTAGE MOVING PARTS!

Failure to follow this Warning could result in property damage, severe personal injury, or death.

Bodily injury can result from high voltage electrical components, fast moving fans, and combustible gas. For protection from these inherent hazards during installation and servicing, the main gas valve must be turned off and the electrical supply must be disconnected. If operating checks must be performed with the unit operating, it is the technician's responsibility to recognize these hazards and proceed safely.

⚠ WARNING

SAFETY HAZARD!

Failure to follow this Warning could result in property damage, severe personal injury, or death.

Do not install the filter in the return duct directly above the furnace in horizontal applications. Install the filter remotely.

⚠ WARNING

SAFETY HAZARD!

Failure to follow this Warning could result in property damage, severe personal injury, or death.

Turn the power to the furnace off before servicing filters to avoid contact with moving parts.

⚠ WARNING

CARBON MONOXIDE HAZARD!

Failure to follow this Warning could result in property damage, severe personal injury, or death.

Furnace venting into an unlined masonry chimney or concrete chimney is prohibited.

⚠ WARNING

CARBON MONOXIDE HAZARD!

Failure to follow this Warning could result in property damage, severe personal injury, or death.

The chimney liner must be thoroughly inspected to insure no cracks or other potential areas for flue gas leaks are present in the liner. Liner leaks will result in early deterioration of the chimney.

⚠ WARNING

SHOCK HAZARD!

Failure to follow this Warning could result in property damage, severe personal injury, or death.

If a disconnect switch is present, it must always be locked in the open position before servicing the unit.

⚠ WARNING

OVERHEATING AND EXPLOSION HAZARD!

Failure to follow this Warning could result in property damage, personal injury or death.

Should overheating occur, or the gas supply fail to shut off, shut off the gas valve to the unit before shutting off the electrical supply.

⚠ CAUTION

IMPROPER VOLTAGE CONNECTION!

Failure to follow this Caution could result in property damage.

Do NOT connect the furnace line voltage to a GFCI protected circuit.

⚠ CAUTION

CORROSION WARNING!

Failure to follow this Caution could result in property damage or personal injury.

Do not install the furnace in a corrosive or contaminated atmosphere.

⚠ CAUTION

SHARP EDGE HAZARD!

Failure to follow this Caution could result in property damage or personal injury.

Be careful of sharp edges on equipment or any cuts made on sheet metal while installing or servicing.

⚠ CAUTION

BACKUP WRENCH REQUIRED!

Failure to follow this Caution could result in property damage or personal injury.

Use a backup wrench on the gas valve when installing gas piping to prevent damage to the gas valve and manifold assembly.

⚠ CAUTION**FREEZE CAUTION!**

Failure to follow this Caution could result in property damage or personal injury. If complete furnace shutdown is done during the cold weather months, provisions must be taken to prevent freeze-up of all water pipes and water receptacles.

⚠ CAUTION**FREEZE CAUTION!**

Failure to follow this Caution could result in property damage or personal injury. Whenever your house is to be vacant, arrange to have someone inspect your house for proper temperature. This is very important during freezing weather. If for any reason your furnace should fail to operate damage could result, such as frozen water pipes.

⚠ CAUTION**IGNITION FUNCTION!**

Failure to follow this Caution may result in poor ignition characteristics. Maintain manifold pressure in high altitude installations.

⚠ CAUTION**WATER DAMAGE!**

Failure to follow this Caution could result in property damage or personal injury. It is recommended that an external overflow drain pan be installed in all applications over a finished ceiling to prevent property damage or personal injury from leaking condensate.

⚠ CAUTION**HOT SURFACE!**

Failure to follow this Caution could result in personal injury. Do NOT touch igniter. It is extremely hot.

⚠ CAUTION**FURNACE SERVICE CAUTION!**

Failure to follow this Caution could result in property damage or personal injury. Label all wires prior to disconnection when servicing controls. Verify proper operation after servicing. Wiring errors can cause improper and dangerous operation.

⚠ CAUTION**DO NOT USE AS CONSTRUCTION HEATER!**

Failure to follow this Caution could result in property damage or personal injury. In order to prevent shortening its service life, the Furnace should NOT be used as a "Construction Heater".

⚠ CAUTION**WIRING INFORMATION!**

Failure to follow this Caution could result in property damage or personal injury. The integrated furnace control is polarity sensitive. The hot leg of the 120 VAC power must be connected to the BLACK field lead.

⚠ CAUTION**EQUIPMENT DAMAGE!**

UV light exposure can cause the plastic blower material to deteriorate which could lead to Blower Housing Damage. For units containing a plastic Blower Housing, Do NOT install third party Ultra-Violet Air Cleaners where the Blower Housing can be exposed to UV light.

For more information, visit www.trane.com and www.americanstandardair.com or contact your installing dealer.
6200 Troup Highway
Tyler, TX 75707

⚠ WARNING

**CARBON MONOXIDE POISONING
HAZARD!**

Failure to follow the steps outlined below for each appliance connected to the venting system being placed into operation could result in carbon monoxide poisoning or death.

The following steps shall be followed for each appliance connected to the venting system being placed into operation, while all other appliances connected to the venting system are not in operation:

- Inspect the venting system for proper size and horizontal pitch as required in the National Fuel Gas Code, ANSI Z223.1/NFPA 54 and these instructions. Determine there is no blockage or restriction, leakage, corrosion or other deficiencies which could cause an unsafe condition.
- Close all doors and windows between the space in which the appliance(s) connected to the venting system are located. Also close fireplace dampers.
- Turn on clothes dryers and any appliance not connected to the venting system. Turn on any exhaust fans such as range hoods so they are operating at maximum speed. Do not operate a summer exhaust fan.
- Follow the lighting instructions. Place the appliance being inspected into operation. Adjust the thermostat so appliance is operating continuously.
- Test for spillage from draft hood equipped appliances at the draft hood relief opening after 5 minutes of main burner operation. Use the flame of a match or candle.
- If improper venting is observed during any of the above tests, the venting system must be corrected in accordance with the National Fuel Gas Code, ANSI Z221.1/NFPA 54.
- After it has been determined that each appliance connected to the venting system properly vents when tested, return all doors, windows, exhaust fans, etc. to their previous condition of use.

Table of Contents

| | | | |
|---|----|--------------------------------------|----|
| Accessories..... | 8 | Return Air Filters | 32 |
| Document Pack Contents..... | 8 | Electrical Connections | 34 |
| Furnace Installation Guidelines..... | 9 | Field Wiring | 34 |
| Safety Practices and Precautions..... | 9 | General Start-up and Adjustment..... | 35 |
| General Guidelines | 9 | Preliminary Inspections | 35 |
| Locations and Clearances | 10 | Lighting Instructions | 35 |
| Outline Drawings..... | 12 | Control and Safety Switch | |
| Furnace General Installation..... | 13 | Adjustment | 35 |
| Furnace Panel Removal | 13 | Furnace Combustion Air Exhaust | |
| Horizontal Installation in an Attic or | | Options..... | 36 |
| Crawlspace | 13 | Combustion Air Conversions | 37 |
| Gas Piping | 14 | Integrated Furnace Control | 39 |
| Combustion and Input Check..... | 17 | Setting Airflow | 40 |
| Gas Valve Adjustment..... | 18 | LED Status Codes..... | 41 |
| High Altitude Derate..... | 19 | Fault Code Recovery | 42 |
| General Venting | 20 | Sequence of Operation | 43 |
| Air for Combustion and Ventilation..... | 22 | | |
| Duct Connections..... | 25 | | |

Accessories

Table 1. Accessories

| Model Number | Description | Use with |
|----------------------------|---------------------------------------|--|
| BAYHANG | Horizontal Hanging Kit | All Furnaces |
| BAYLIFTB | Dual Return Kit (B size extension) | B Cabinet Furnaces |
| BAYSF1165AA ^(a) | 1" SlimFit Box with MERV 4 Filter | All Furnaces |
| BAYSF1255BA | 1" SlimFit Filter and Insulated Frame | All furnaces when used in side return application B Cabinet furnaces only when in bottom return application |
| FLRSF1255 | 1" Filter replacement (Qty 12) | BAYSF1255BA |
| BAYVENT800B | Masonry Chimney Vent Kit | All furnaces |
| PIPO2095 | U fitting for gas piping | All Furnaces for right hand gas entry |
| BAYHALTMOD0001 | High Altitude ID Plug | L8X1B060U3XS** |
| BAYHALTMOD0002 | High Altitude ID Plug | L8X1B080U4XS** |

^(a) Airflow greater than 1600 CFM requires dual returns

Document Pack Contents

| Item | Qty. | Description |
|------|------|--|
| 1 | 1 | Plug — Gas |
| 2 | 1 | Installer's Guide |
| 3 | 1 | Service Facts |
| 4 | 1 | Owner Guide |
| 5 | 1 | Limited Warranty |
| 6 | 2 | Tinnerman Clips (not pictured) Note: Tinnerman Clips should be kept with unit and are used if the door panel flange hole (s) becomes stripped. |

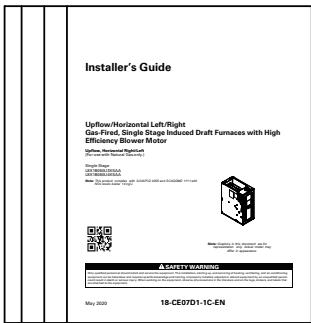

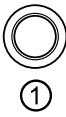



Furnace Installation Guidelines

The following sections give general guidelines for the installation of the gas furnaces.

Safety Practices and Precautions

The following safety practices and precautions must be followed during the installation, servicing, and operation of this Furnace.

1. Use only with the type gas approved for this Furnace. Refer to the Furnace rating plate.
2. Install the Furnace only in a location and position as specified in "Locations and Clearances" of these instructions.
3. Provide adequate combustion and ventilation air to the Furnace space as specified in "Air for Combustion and Ventilation" of these instructions.
4. Combustion products must be discharged outdoors. Connect this Furnace to an approved vent system only, as specified in the "Venting" section of these instructions.
5. Never test for gas leaks with an open flame. Use a commercially available soap solution made specifically for the detection of leaks to check all connections, as specified in the "Gas Piping" section of these instructions.
6. Always install the Furnace to operate within the Furnace's intended temperature-rise range with a duct system which has an external static pressure within the allowable range, as specified on the unit rating plate. Airflow within temperature rise for cfm versus static is shown in the Service Facts accompanying this Furnace.
7. When a Furnace is installed so that the supply ducts carry air circulated by the Furnace to areas outside the space containing the Furnace, the return air shall also be handled by a duct(s) sealed to the Furnace casing and terminating outside the space containing the Furnace.
8. A gas-fired Furnace for installation in a residential garage must be installed as specified in "Location and Clearances" section of these instructions.
9. The Furnace return air temperature range is between 55 and 80 Fahrenheit.
10. The furnace, under any circumstance may NOT be used during construction phase of the building or structure.

11. In the Commonwealth of Massachusetts, this product must be gas piped by a Licensed Plumber or Gas Fitter.

This Furnace is certified to leak 1% or less of nominal air conditioning CFM delivered when pressurized to .5" water column with all inlets, outlets, and drains sealed.

General Guidelines

The manufacturer assumes no responsibility for equipment installed in violation of any code or regulation.

It is recommended that Manual J of the Air Conditioning Contractors Association (ACCA) or A.R.I. 230 be followed in estimating heating requirements. When estimating heating requirements for installation at Altitudes above 2000 ft., remember the gas input must be reduced. See Combustion and Input Check.

Material in this shipment has been inspected at the factory and released to the transportation agency without known damage. Inspect exterior of carton for evidence of rough handling in shipment. Unpack carefully after moving equipment to approximate location. If damage to contents is found, report the damage immediately to the delivering agency.

Codes and local utility requirements governing the installation of gas fired equipment, wiring, plumbing, and flue connections must be adhered to. In the absence of local codes, the installation must conform with latest edition of the National Fuel Gas Code ANSI Z223.1 / NFPA 54. The latest code may be obtained from the American Gas Association Laboratories, 400 N. Capitol St. NW, Washington D.C. 20001. 1-800-699-9277 or www.aga.org.

These furnaces have been classified as Fan Assisted Combustion system CATEGORY I furnaces as required by ANSI Z21.47 "latest edition". Therefore they do not require any special provisions for venting other than what is indicated in these instructions.

Warning: These furnaces are not approved or intended for installation in manufactured (mobile) housing, trailers, or recreational vehicles.

Locations and Clearances

The location of the Furnace is normally selected by the architect, the builder, or the installer. However, before the Furnace is moved into place, be sure to consider the following requirements:

1. Is the location selected as near the chimney or vent and as centralized for heat distribution as practical?
2. Do all clearances between the Furnace and enclosure equal or exceed the minimums stated in Clearance Table below?

Minimum clearance to combustible materials

INSTALLATION CLEARANCE TO COMBUSTIBLE CONSTRUCTION

THIS FURNACE IS APPROVED FOR UPFLOW AND HORIZONTAL APPLICATIONS ONLY.

+FOR HORIZONTAL APPLICATIONS
14.5" CABINETS, 1" SIDES
17.5" CABINETS, 1" SIDES
21.0" CABINETS, 1" SIDES

NOTES:
1: MUST FOLLOW NATIONAL FUEL & GAS CODES FOR INSTALLS.
2: TYPE B-1 VENT CLEARANCE IS 1".
3: SINGLE WALL VENT NOT PERMITTED.
4: "SIDE" IN HORIZONTAL ARE THE SUPPLY AND RETURN.

LINE CONTACT ONLY PERMISSIBLE BETWEEN LINES FORMED BY INTERSECTIONS OF THE TOP AND TWO SIDES OF THE FURNACE JACKET, AND BUILDING JOISTS, STUDS OR FRAMING.

D346216P01 REV B

3. Is there sufficient space for servicing the Furnace and other equipment? A minimum of 24 inches front accessibility to the Furnace must be provided. Any access door or panel must permit removal of the largest component.
4. Are there at least 3 inches of clearance between the Furnace combustion air openings in the front panel and any closed panel or door provided?
5. Are the ventilation and combustion air openings large enough and will they remain unobstructed? If

- outside air is used, are the openings set 12" above the highest snow accumulation level?
6. Allow sufficient height in supply plenum above the furnace to provide for cooling coil installation, if the cooling coil is not installed at the time of this Furnace installation.
7. The Furnace shall be installed so electrical components are protected from water.
8. If the Furnace is installed in a garage, it must be installed so that the burners, and the ignition source are located not less than 18 inches above the

floor and the Furnace must be located or protected to avoid physical damage from vehicles.

9. The gas furnace must not be located where excessive exposure to contaminated combustion air will result in safety and performance related problems. Avoid the following known contaminants:
 - a. Permanent wave solutions
 - b. Chlorinated waxes and cleaners
 - c. Chlorine based swimming pool chemicals
 - d. Water softening chemicals
 - e. De-icing salts or chemicals
 - f. Carbon tetrachloride
 - g. Halogen type refrigerants
 - h. Cleaning solvents (such as perchloroethylene)
 - i. Printing inks, paint removers, varnishes, etc.
 - j. Hydrochloric acid
 - k. Cements and glues
 - l. Antistatic fabric softeners for clothes dryers
 - m. Masonry acid washing materials

Furnace General Installation

The following sections give general instructions for the installation of the gas furnaces.

Furnace Panel Removal

Note: For the L8X1 furnace, a 1/4" nut driver is required to remove the two screws at the top of the front panel. The front panel can then be removed by lifting upwards.

Note: Tinnerman clips are provided in the doc pack if the door panel flange hole(s) becomes stripped.

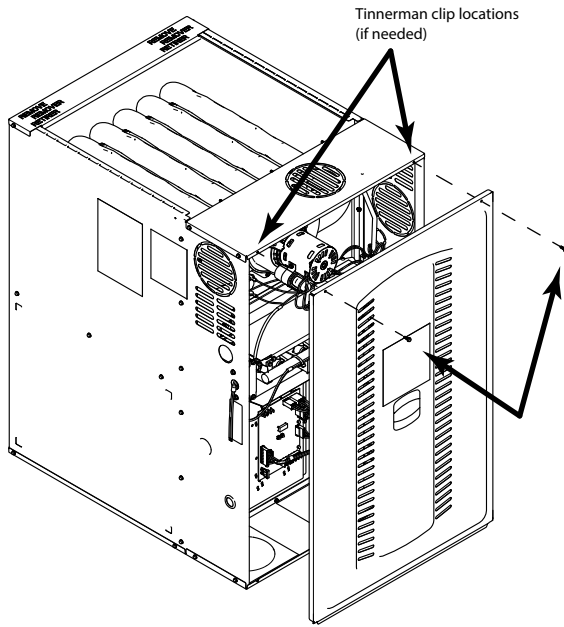

Horizontal Installation in an Attic or Crawl Space

The non-condensing furnace may be installed in an attic or crawl space in the horizontal position by placing the furnace on its left or right side (as viewed from the front in the vertical position). The horizontal furnace installation in an attic should be on a service platform large enough to allow for proper clearances on all sides and service access to the front of the furnace. See the " ". Line contact is only permissible between lines formed by intersections of the top and two sides of the furnace casing and building joists, studs, or framing.

The furnace may be placed horizontally in a crawl space on a pad or other noncombustible material. Place blocks underneath to support the furnace and raise the unit for sufficient protection from moisture.

The furnace may be installed hanging in a hanging position using straps. The furnace should be supported at both ends and have an additional support in the center of the furnace in back.

WHEN SUSPENDING THE HORIZONTAL FURNACE, IT SHOULD BE SUSPENDED BY ATTACHING TO THE CABINET IN THE PLACES SHOWN.

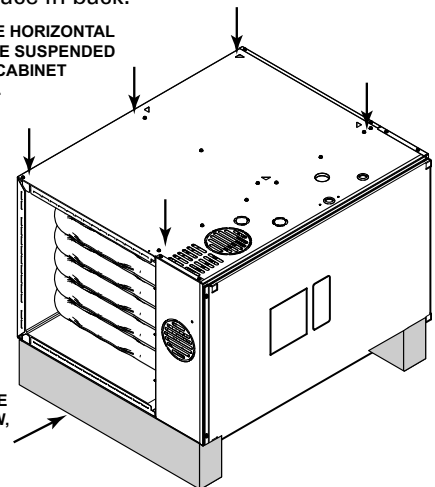

Gas Piping

Important: The furnace default is left side gas piping.

Note: For ease of installation, optional accessory part PIP02095 is recommended for gas piping entering the right side of the furnace.

Furnace in upflow orientation with gas piping on left

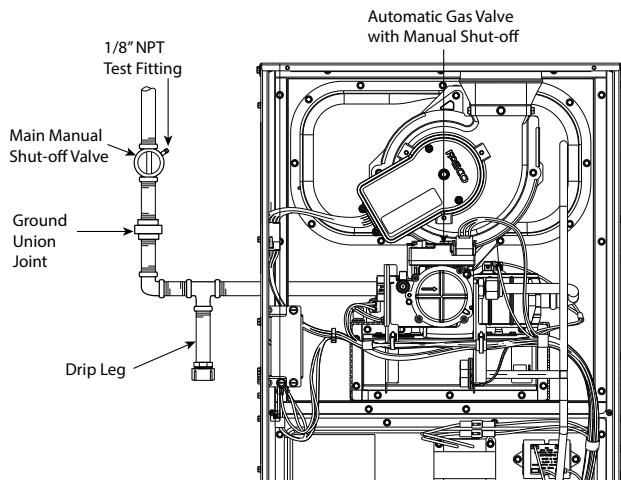

Furnace in upflow orientation with gas piping on right

Note: For ease of installation, optional accessory part PIP02095 is recommended for gas piping entering the right side of the furnace in the upflow orientation.

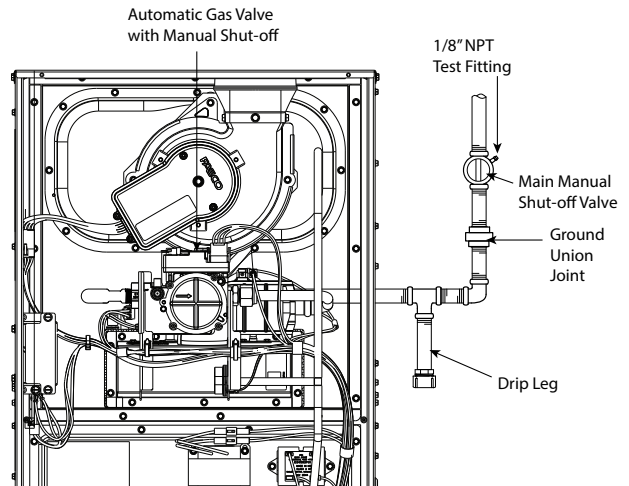

Note: For ease of installation, optional accessory part PIP02095 is recommended for gas piping entering the right side of the furnace.

Furnace in horizontal left orientation with gas piping out top

Note: For ease of installation, optional accessory part PIP02095 is recommended for gas piping entering the top of the furnace in the horizontal left position.

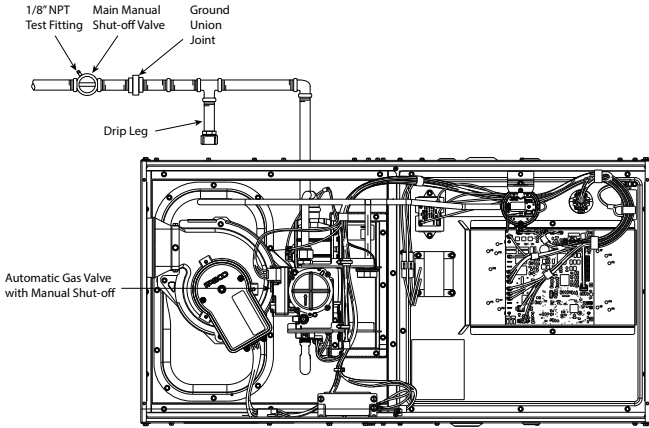

Furnace in horizontal left orientation with gas piping out bottom

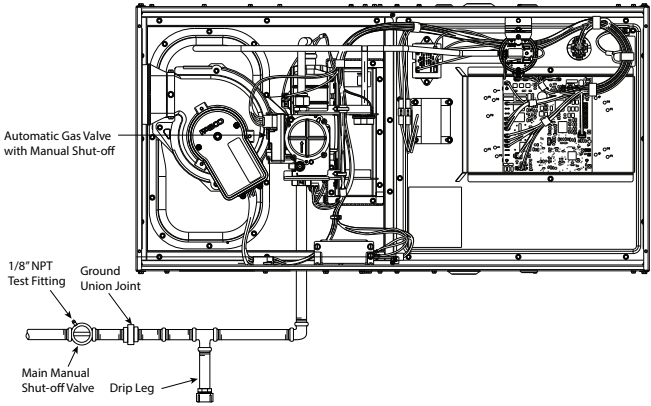

Furnace in horizontal right orientation with gas piping out top

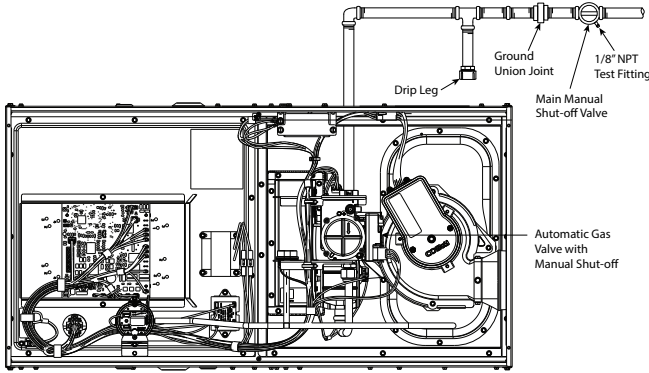

Furnace in horizontal right orientation with gas piping out bottom

Note: For ease of installation, optional accessory part PIP02095 is recommended for gas piping entering the bottom of the furnace in the horizontal right position.

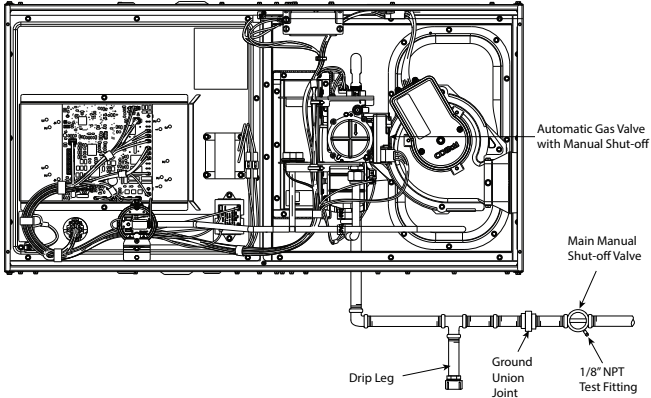

Furnace General Installation

| <p>The furnace is shipped standard for left side installation of gas piping. A cutout with plug is provided on the right side for an alternate gas piping arrangement.</p> <p>The installation of piping shall be in accordance with piping codes and the regulations of the local gas company. Pipe joint compound must be resistant to the chemical reaction with liquefied petroleum gases.</p> <p>Important: <i>If local codes allow the use of flexible gas appliance connector, always use a new listed connector. Do not use a connector which has previously serviced another gas appliance.</i></p> <p>Refer to the piping table for delivery sizes. Connect gas supply to the unit, using a ground joint union and a manual shut-off valve. National codes require a condensation drip leg to be installed ahead of the gas valve.</p> <p>The furnace and its individual shut-off valve must be disconnected from the gas supply piping system during any pressure testing of that system at test pressures in excess of 1/2 psig (3.5 kPa).</p> <p>The furnace must be isolated from the gas supply piping by closing its individual manual shut-off valve during any pressure testing of the gas supply piping system at test pressures equal to or less than 1/2 psig (3.5 kPa).</p> <p>Note: <i>Maximum pressure to the gas valve for natural gas is 13.8" W.C. Minimum pressure is 5.0" W.C.</i></p> | <table border="1" style="width: 100%; text-align: center;"> <tr> <td colspan="8">NATURAL GAS ONLY</td> </tr> <tr> <td colspan="8">TABLE OF CUBIC FEET PER HOUR OF GAS FOR VARIOUS PIPE SIZES AND LENGTHS</td> </tr> <tr> <th rowspan="2">PIPE SIZE</th> <th colspan="7">LENGTH OF PIPE</th> </tr> <tr> <th>10</th> <th>20</th> <th>30</th> <th>40</th> <th>50</th> <th>60</th> <th>70</th> </tr> <tr> <td>1/2</td> <td>131</td> <td>90</td> <td>72</td> <td>62</td> <td>55</td> <td>50</td> <td>46</td> </tr> <tr> <td>3/4</td> <td>273</td> <td>188</td> <td>151</td> <td>129</td> <td>114</td> <td>104</td> <td>95</td> </tr> <tr> <td>1</td> <td>514</td> <td>353</td> <td>284</td> <td>243</td> <td>215</td> <td>195</td> <td>179</td> </tr> <tr> <td>1-1/4</td> <td>1060</td> <td>726</td> <td>583</td> <td>499</td> <td>442</td> <td>400</td> <td>368</td> </tr> <tr> <td colspan="8">This table is based on Pressure Drop of 0.3 inch W.C. and 0.6 SP. GR. Gas</td> </tr> </table> | NATURAL GAS ONLY | | | | | | | | TABLE OF CUBIC FEET PER HOUR OF GAS FOR VARIOUS PIPE SIZES AND LENGTHS | | | | | | | | PIPE SIZE | LENGTH OF PIPE | | | | | | | 10 | 20 | 30 | 40 | 50 | 60 | 70 | 1/2 | 131 | 90 | 72 | 62 | 55 | 50 | 46 | 3/4 | 273 | 188 | 151 | 129 | 114 | 104 | 95 | 1 | 514 | 353 | 284 | 243 | 215 | 195 | 179 | 1-1/4 | 1060 | 726 | 583 | 499 | 442 | 400 | 368 | This table is based on Pressure Drop of 0.3 inch W.C. and 0.6 SP. GR. Gas | | | | | | | |
|---|--|--------------------------------|-----|-----|-------------------|-------------------|--------------------------------|----------|--------|---|---------|--------|---|---------|--|--|--|-----------|----------------|--|--|--|--|--|--|----|----|----|----|----|----|----|-----|-----|----|----|----|----|----|----|-----|-----|-----|-----|-----|-----|-----|----|---|-----|-----|-----|-----|-----|-----|-----|-------|------|-----|-----|-----|-----|-----|-----|---|--|--|--|--|--|--|--|
| NATURAL GAS ONLY | | | | | | | | | | | | | | | | | | | | | | | | | | | | | | | | | | | | | | | | | | | | | | | | | | | | | | | | | | | | | | | | | | | | | | | | |
| TABLE OF CUBIC FEET PER HOUR OF GAS FOR VARIOUS PIPE SIZES AND LENGTHS | | | | | | | | | | | | | | | | | | | | | | | | | | | | | | | | | | | | | | | | | | | | | | | | | | | | | | | | | | | | | | | | | | | | | | | | |
| PIPE SIZE | LENGTH OF PIPE | | | | | | | | | | | | | | | | | | | | | | | | | | | | | | | | | | | | | | | | | | | | | | | | | | | | | | | | | | | | | | | | | | | | | | | |
| | 10 | 20 | 30 | 40 | 50 | 60 | 70 | | | | | | | | | | | | | | | | | | | | | | | | | | | | | | | | | | | | | | | | | | | | | | | | | | | | | | | | | | | | | | | | | |
| 1/2 | 131 | 90 | 72 | 62 | 55 | 50 | 46 | | | | | | | | | | | | | | | | | | | | | | | | | | | | | | | | | | | | | | | | | | | | | | | | | | | | | | | | | | | | | | | | | |
| 3/4 | 273 | 188 | 151 | 129 | 114 | 104 | 95 | | | | | | | | | | | | | | | | | | | | | | | | | | | | | | | | | | | | | | | | | | | | | | | | | | | | | | | | | | | | | | | | | |
| 1 | 514 | 353 | 284 | 243 | 215 | 195 | 179 | | | | | | | | | | | | | | | | | | | | | | | | | | | | | | | | | | | | | | | | | | | | | | | | | | | | | | | | | | | | | | | | | |
| 1-1/4 | 1060 | 726 | 583 | 499 | 442 | 400 | 368 | | | | | | | | | | | | | | | | | | | | | | | | | | | | | | | | | | | | | | | | | | | | | | | | | | | | | | | | | | | | | | | | | |
| This table is based on Pressure Drop of 0.3 inch W.C. and 0.6 SP. GR. Gas | | | | | | | | | | | | | | | | | | | | | | | | | | | | | | | | | | | | | | | | | | | | | | | | | | | | | | | | | | | | | | | | | | | | | | | | |
| <p>All gas fittings must be checked for leaks using a soapy solution before lighting the furnace. DO NOT CHECK WITH AN OPEN FLAME!</p> | <table border="1" style="width: 100%; text-align: center;"> <tr> <td colspan="3">ORIFICE SIZES</td> </tr> <tr> <th rowspan="2">INPUT RATING BTUH</th> <th rowspan="2">NUMBER OF BURNERS</th> <th>MAIN BURNER ORIFICE DRILL SIZE</th> </tr> <tr> <th>NAT. GAS</th> </tr> <tr> <td>60,000</td> <td>1</td> <td>1 - #23</td> </tr> <tr> <td>80,000</td> <td>1</td> <td>1 - #15</td> </tr> </table> | ORIFICE SIZES | | | INPUT RATING BTUH | NUMBER OF BURNERS | MAIN BURNER ORIFICE DRILL SIZE | NAT. GAS | 60,000 | 1 | 1 - #23 | 80,000 | 1 | 1 - #15 | | | | | | | | | | | | | | | | | | | | | | | | | | | | | | | | | | | | | | | | | | | | | | | | | | | | | | | | | | |
| ORIFICE SIZES | | | | | | | | | | | | | | | | | | | | | | | | | | | | | | | | | | | | | | | | | | | | | | | | | | | | | | | | | | | | | | | | | | | | | | | | |
| INPUT RATING BTUH | NUMBER OF BURNERS | MAIN BURNER ORIFICE DRILL SIZE | | | | | | | | | | | | | | | | | | | | | | | | | | | | | | | | | | | | | | | | | | | | | | | | | | | | | | | | | | | | | | | | | | | | | | |
| | | NAT. GAS | | | | | | | | | | | | | | | | | | | | | | | | | | | | | | | | | | | | | | | | | | | | | | | | | | | | | | | | | | | | | | | | | | | | | | |
| 60,000 | 1 | 1 - #23 | | | | | | | | | | | | | | | | | | | | | | | | | | | | | | | | | | | | | | | | | | | | | | | | | | | | | | | | | | | | | | | | | | | | | | |
| 80,000 | 1 | 1 - #15 | | | | | | | | | | | | | | | | | | | | | | | | | | | | | | | | | | | | | | | | | | | | | | | | | | | | | | | | | | | | | | | | | | | | | | |

Combustion and Input Check

1. Make sure all gas appliances are off except the furnace.
2. Clock the gas meter with the furnace operating (determine the dial rating of the meter) for one revolution.
3. Match the "Sec" column in the gas flow table with the time clocked.
4. Read the "Flow" column opposite the number of seconds clocked.
5. Use the following factors *if necessary*:
 - a. For 1 Cu. Ft. Dial Gas Flow CFH = Chart Flow Reading ÷ 2
 - b. For 1/2 Cu Ft. Dial Gas Flow CFH = Chart Flow Reading ÷ 4
 - c. For 5 Cu. Ft. Dial Gas Flow CFH = 10X Chart Flow Reading ÷ 4
6. Multiply the final figure by the heating value of the gas obtained from the utility company and compare to the nameplate rating. This must not exceed the nameplate rating.

| Gas Flow in Cubic Feet Per Hour | | | | | | | |
|---------------------------------|------|------|------|------|------|------|------|
| 2 Cubic Foot Dial | | | | | | | |
| Sec. | Flow | Sec. | Flow | Sec. | Flow | Sec. | Flow |
| 10 | 732 | 31 | 236 | 52 | 141 | 86 | 85 |
| 11 | 666 | 32 | 229 | 53 | 138 | 88 | 83 |
| 12 | 610 | 33 | 222 | 54 | 136 | 90 | 81 |
| 13 | 563 | 34 | 215 | 55 | 133 | 94 | 78 |
| 14 | 523 | 35 | 209 | 56 | 131 | 98 | 75 |
| 15 | 488 | 36 | 203 | 57 | 128 | 100 | 73 |
| 16 | 458 | 37 | 198 | 58 | 126 | 104 | 70 |
| 17 | 431 | 38 | 193 | 59 | 124 | 108 | 68 |
| 18 | 407 | 39 | 188 | 60 | 122 | 112 | 65 |
| 19 | 385 | 40 | 183 | 62 | 118 | 116 | 63 |
| 20 | 366 | 41 | 179 | 64 | 114 | 120 | 61 |
| 21 | 349 | 42 | 174 | 66 | 111 | 130 | 56 |
| 22 | 333 | 43 | 170 | 68 | 108 | 140 | 52 |
| 23 | 318 | 44 | 166 | 70 | 105 | 150 | 49 |
| 24 | 305 | 45 | 163 | 72 | 102 | 160 | 46 |
| 25 | 293 | 46 | 159 | 74 | 99 | 170 | 43 |
| 26 | 282 | 47 | 156 | 76 | 96 | 180 | 41 |
| 27 | 271 | 48 | 153 | 78 | 94 | 190 | 39 |
| 28 | 262 | 49 | 149 | 80 | 92 | 200 | 37 |
| 29 | 253 | 50 | 146 | 82 | 89 | | |
| 30 | 244 | 51 | 144 | 84 | 87 | | |

Gas Valve Adjustment

Note: The gas valve supplied with this unit has been calibrated specifically for the Ultra Lo-NOx ignition system. Adjustment is not typically necessary.

Manifold pressure adjustments are only recommended when there are ignition light-off, flame stabilization, or tonal issues with the furnace.

To adjust the manifold pressure:

1. Turn off all electrical power to the system.
2. Attach a manifold pressure gauge with flexible tubing to the outlet pressure boss marked "OUT P" on White- Rodgers gas valve model 36J.
3. Loosen (Do Not remove) the pressure tap test set screw one turn with 3/32" hex wrench.
 - a. The pressure tap adjustment kit (KIT07611) contains a 3/32" hex wrench, a 5/16" hose and a connector and can be ordered through Global Parts.
4. Turn on system power and make a call for heating.
5. To adjust the run manifold pressure, remove the high (HI) adjustment regulator cover screw.
 - a. To increase outlet pressure, turn the regulator adjust screw clockwise.
 - b. To decrease outlet pressure, turn the regulator adjust screw counterclockwise.
 - c. Adjust regulator until pressure shown on manometer matches the pressure specified in the table.

The input of no more than nameplate rating and no less than 93% of the nameplate rating, unless the unit is derated for high altitude.
 - d. Replace and tighten the regulator cover screw securely.
6. To adjust the light off manifold pressure, remove the low (LO) adjustment regulator cover screw.
 - a. To increase outlet pressure, turn the regulator adjust screw clockwise.
 - b. To decrease outlet pressure, turn the regulator adjust screw counterclockwise.
 - c. Adjust regulator until pressure shown on manometer matches the pressure specified in the table.

The input of no more than nameplate rating and no less than 93% of the nameplate rating, unless the unit is derated for high altitude.
 - d. Replace and tighten the regulator cover screw securely.
7. Cycle the furnace several times to verify regulator setting.
 - a. Repeat steps 5-7 if needed.
8. Turn off all electrical power to the system.
9. Remove the manometer and flexible tubing and tighten the pressure tap screw.
10. Using a leak detection solution or soap suds, check for leaks at the pressure outlet boss and pressure tap test screw.
11. Turn on system power and check operation of the unit.

White-Rodgers 36J

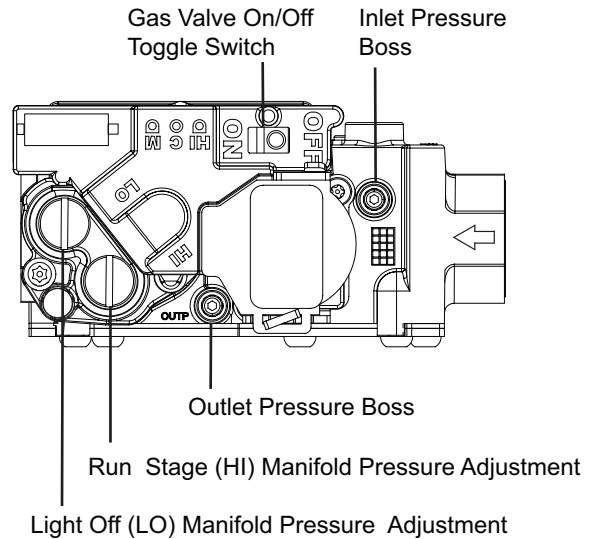

| Maximum and Minimum INLET Pressure (inches w.c.) | |
|--|--|
| Natural Gas | |
| Maximum | 13.8 |
| Minimum | 5 |
| Recommended Fuel Manifold Settings (inches w.c.) | |
| L8X1B060U3XS L8X1B080U4XS | 2.1" Light-Off (LO) / 3.0" Run (HI) |
| Orifice sizes for Natural Gas | |
| L8X1B060U3XS L8X1B080U4XS | #23 #15 |

High Altitude Derate

| <p>Input ratings (BTUH) of these Furnaces are based on sea level operation and should not be changed at elevations up to 2,000 ft. (610 m).</p> <p>If the installation is 2,000 ft. (610 m) or above, the Furnace input rate (BTUH) shall be reduced 4% for each 1,000 ft. above sea level.</p> <p>The Furnace input rate shall be checked by clocking the gas flow rate (CFH) and multiplying by the heating value obtained from the local utility supplier for the gas being delivered at the installed altitude. Input rate changes can be made by adjusting the Manifold Pressure (min 3.0 - max 3.7 in. W.C. - Natural Gas).</p> <p>If the desired input rate can not be achieved with a change in Manifold Pressure, then the orifices must be changed.</p> | <table border="1"> <thead> <tr> <th colspan="2">PART NUMBERS FOR REPLACEMENT ORIFICES</th> </tr> <tr> <th>DRILL SIZE</th> <th>PART NUMBER</th> </tr> </thead> <tbody> <tr> <td>B60 = #23</td> <td></td> </tr> <tr> <td>B80 = #15</td> <td></td> </tr> </tbody> </table> | PART NUMBERS FOR REPLACEMENT ORIFICES | | DRILL SIZE | PART NUMBER | B60 = #23 | | B80 = #15 | | | | | | | | | |
|---|--|---------------------------------------|-----------------|------------|-------------|------------|-------------|----------------|----------------|------------------|-----|-----|-----------------|------------------|-----|-----------------|-----------------|
| PART NUMBERS FOR REPLACEMENT ORIFICES | | | | | | | | | | | | | | | | | |
| DRILL SIZE | PART NUMBER | | | | | | | | | | | | | | | | |
| B60 = #23 | | | | | | | | | | | | | | | | | |
| B80 = #15 | | | | | | | | | | | | | | | | | |
| <p>Turn the main Gas Valve toggle switch within the unit to the "OFF" position. Turn the external gas valve to "ON". Purge the air from the gas lines. After purging, check all gas connections for leaks with a soapy solution – DO NOT CHECK WITH AN OPEN FLAME. Allow 5 minutes for any gas that might have escaped to dissipate.</p> | <p>Note: For furnaces requiring modifications other than manifold pressure adjustment for installation at high altitude, installation of this furnace at altitudes above 2000 ft (610 m) shall be made in accordance with the listed High Altitude Conversion Kit available with this furnace.</p> <table border="1"> <thead> <tr> <th colspan="4">High Altitude Kits</th> </tr> <tr> <th>Attributes</th> <th>0 - 2000 ft</th> <th>2000 - 5400 ft</th> <th>5400 - 7800 ft</th> </tr> </thead> <tbody> <tr> <td>B60 3 Ton</td> <td>N/A</td> <td>N/A</td> <td>BAYHALT-MOD0001</td> </tr> <tr> <td>B80 4 Ton</td> <td>N/A</td> <td>BAYHALT-MOD0002</td> <td>BAYHALT-MOD0002</td> </tr> </tbody> </table> | High Altitude Kits | | | | Attributes | 0 - 2000 ft | 2000 - 5400 ft | 5400 - 7800 ft | B60 3 Ton | N/A | N/A | BAYHALT-MOD0001 | B80 4 Ton | N/A | BAYHALT-MOD0002 | BAYHALT-MOD0002 |
| High Altitude Kits | | | | | | | | | | | | | | | | | |
| Attributes | 0 - 2000 ft | 2000 - 5400 ft | 5400 - 7800 ft | | | | | | | | | | | | | | |
| B60 3 Ton | N/A | N/A | BAYHALT-MOD0001 | | | | | | | | | | | | | | |
| B80 4 Ton | N/A | BAYHALT-MOD0002 | BAYHALT-MOD0002 | | | | | | | | | | | | | | |

General Venting

VENT PIPING

These furnaces have been classified as Fan-Assisted Combustion System, Category I furnaces under the "latest edition" provisions of ANSI Z21.47 standards. Category I furnaces operate with a non-positive vent static pressure and with a flue loss of not less than 17 percent.

Important: To reduce the combustion back pressure tones that may occur, the minimum overall length of B-vent must be 7 feet.

Multistory and common venting are permitted for these furnaces. Venting systems shall be in accordance with the National Fuel Gas Code, ANSI Z223.1/NFPA 54, local codes, and this installation manual.

Side wall termination with the use of an add-on draft inducer is not allowed with this furnace.

The furnace shall be connected to a factory built chimney or vent complying with a recognized standard, or a masonry or concrete chimney lined with a lining material acceptable to the authority having jurisdiction.

VENTING INTO A MASONRY CHIMNEY

If the chimney is oversized, the liner is inadequate, or flue-gas condensation is a problem in your area, consider using the chimney as a pathway or chase for type "B" vent or flexible vent liner. If flexible liner material is used, size the vent using the "B" vent tables, then reduce the maximum capacity by 20% (multiply 0.80 times the maximum capacity). Masonry Chimney Kit BAYVENT800B may be used with these furnaces (**Upflow model furnaces only**) to allow venting into a masonry chimney. Refer to the BAYVENT800B Installer's Guide for application requirements.

INTERNAL MASONRY CHIMNEYS

Venting of fan assisted appliances into a lined, internal masonry chimney is allowed only if it is common vented with at least one natural draft appliance; **OR**, if the chimney is lined with type "B", double wall vent or suitable flexible liner material

⚠ WARNING

Safety Hazard!

Failure to follow this warning could result in carbon monoxide poisoning or death.

The chimney liner must be thoroughly inspected to insure no cracks or other potential areas for flue gas leaks are present in the liner. Liner leaks will result in early deterioration of the chimney.

The following section does not apply if BAYVENT800B (Masonry Chimney Vent Kit) is used. All instructions with the kit must be followed.

| Masonry Chimney Venting | | | | |
|-------------------------|--------------------|----------|----------------|----------------------|
| Type Furnace | Tile Lined Chimney | | Chimney Lining | |
| | Internal | External | "B" Vent | Flexible Metal Liner |
| Single Fan Assist | No | No | Yes | Yes ^(a) |
| Fan Assist + Fan Assist | No | No | Yes | Yes ^(a) |
| Fan Assist + Natural | Yes | No | Yes | Yes ^(a) |

^(a) Flexible chimney liner size is determined by using the type "B" vent size for the available BTUH input, then reducing the maximum capacity by 20% (multiply maximum capacity times 0.80). The minimum capacity is the same as shown in the "B" vent tables.

EXTERNAL MASONRY CHIMNEY

Venting of fan assisted appliances into external chimneys (one or more walls exposed to outdoor temperatures), requires the chimney be lined with type "B", double wall vent or suitable flexible chimney liner material. This applies in all combinations of common venting as well as for fan assisted appliances vented alone.

The following installation practices are recommended to minimize corrosion caused by condensation of flue products in the furnace and flue gas system.

1. Avoid an excessive number of bends.
2. Horizontal runs should pitch upward at least 1/4" per foot.
3. Horizontal runs should be as short as possible.
4. All vent pipe or connectors should be securely supported and must be inserted into, but not beyond the inside wall at the chimney vent.
5. When vent connections must pass through walls or partitions of combustible material, a thimble must be used and installed according to local codes.
6. Vent pipe through the roof should be extended to a height determined by National Fuel Gas Code or local codes. It should be capped properly to prevent rain water from entering the vent. Roof exit should be waterproofed.
7. Use type "B" double wall vent when vent pipe is routed through cool spaces (below 60° F.).
8. Where long periods of airflow are desired for comfort, use long fan cycles instead of continuous airflow.
9. Apply other good venting practices as stated in the venting section of the National Fuel Gas Code ANSI Z223.1 "latest edition".
10. **Vent connectors serving appliance vented by natural draft or non-positive pressure shall not be connected into any portion of a mechanized draft system operating under positive pressure.**
11. Horizontal pipe runs must be supported by hangers, straps or other suitable material in intervals at a minimum of every 3 feet of pipe.
12. A furnace shall not be connected to a chimney or flue serving a separate appliance designed to burn solid fuel.
13. The flow area of the largest section of vertical vent or chimney shall not exceed 7 times the smallest listed appliance categorized vent area, flue collar area, or draft hood outlet area unless designed in accordance with approved engineering methods.

Maximum Vent or Tile Lined Chimney Flow Area = $[\pi(D^*)^2] / 4 \times 7$

* Draft hood outlet diameter, flue collar diameter, or listed appliance categorized vent diameter.

Gas Vent Termination

| Roof Pitch | Minimum Height |
|---------------------|-------------------------|
| Flat to 6/12 | 1.0 Feet ^(a) |
| Over 6/12 to 7/12 | 1.25 Feet |
| Over 7/12 to 8/12 | 1.5 Feet |
| Over 8/12 to 9/12 | 2.0 Feet |
| Over 9/12 to 10/12 | 2.5 Feet |
| Over 10/12 to 11/12 | 3.25 Feet |
| Over 11/12 to 12/12 | 4.0 Feet |
| Over 12/12 to 14/12 | 5.0 Feet |
| Over 14/12 to 16/12 | 6.0 Feet |
| Over 16/12 to 18/12 | 7.0 Feet |
| Over 18/12 to 20/12 | 7.5 Feet |
| Over 20/12 to 22/12 | 8.0 Feet |

^(a) This requirement covers most installations

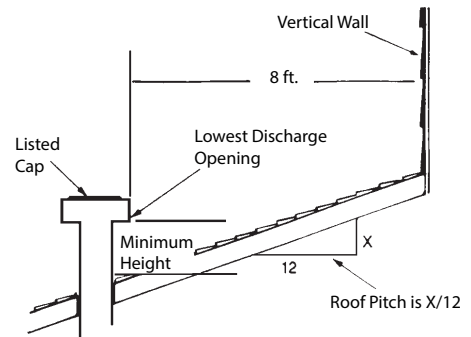

The vent termination should not be less than 8 ft. from a vertical wall.

^(a) This requirement covers most installations

Air for Combustion and Ventilation

Adequate flow of combustion and ventilating air must not be obstructed from reaching the Furnace. Air openings provided in the Furnace casing must be kept free of obstructions which restrict the flow of air. Airflow restrictions affect the efficiency and safe operation of the Furnace. Keep this in mind should you choose to remodel or change the area which contains your Furnace. Furnaces must have a free flow of air for proper performance.

Provisions for combustion and ventilation air shall be made in accordance with "latest edition" of Section 9.3, Air for Combustion and Ventilation, of the National Fuel Gas Code, ANSI Z223.1 / NFPA 54. Installation Codes, and applicable provisions of the local building codes. Special conditions created by mechanical exhausting of air and fireplaces must be considered to avoid unsatisfactory Furnace operation.

Furnace location may be in an **unconfined** space or a **confined** space.

Unconfined space are installations with 50 cu. ft. or more per 1000 BTU/hr input from all equipment installed. Unconfined spaces are defined in the table and illustration for various furnace sizes. These spaces may have adequate air by infiltration to provide air for combustion, ventilation, and dilution of flue gases. Buildings with tight construction (for example, weather stripping, heavily insulated, caulked, vapor barrier, etc.), may need additional air provided as described for confined space.

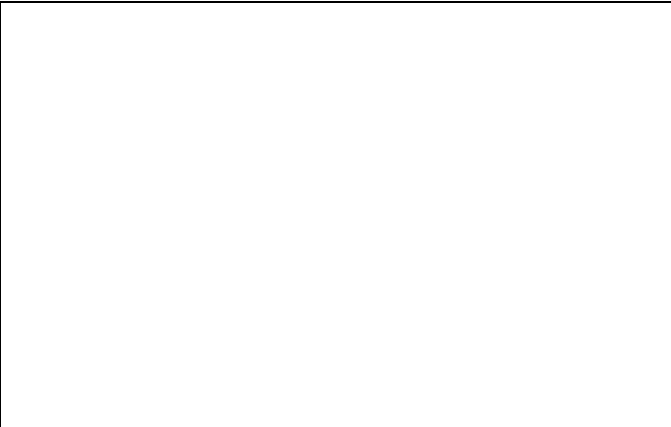

Minimum Area in Square Feet for Unconfined Space Installations

| Furnace Maximum BTUH Input Rating | With 8 Ft. Ceiling, Minimum Area in Square Feet of Unconfined Space |
|-----------------------------------|---|
| 60,000 | 375 |
| 80,000 | 500 |

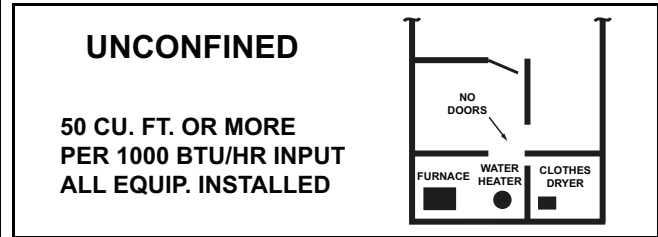

Confined spaces are installations with less than 50 cu. ft. of space per 1000 BTU/ hr input from all equipment installed. Confined spaces are defined in the table and illustration for various furnace sizes. Air for combustion and ventilation requirements can be supplied from inside the building.

1. The following types of installations will **require** use of OUTDOOR AIR for combustion, due to chemical exposures:

- * Commercial buildings
- * Buildings with indoor pools
- * Furnaces installed in commercial laundry rooms
- * Furnaces installed in hobby or craft rooms
- * Furnaces installed near chemical storage areas

Exposure to the following substances in the combustion air supply will also require OUTDOOR AIR for combustion:

- * Permanent wave solutions
- * Chlorinated waxes and cleaners
- * Chlorine based swimming pool chemicals
- * Water softening chemicals
- * Deicing salts or chemicals
- * Carbon Tetrachloride
- * Halogen type refrigerants
- * Cleaning solvents (such as perchloroethylene)
- * Printing inks, paint removers, varnish, etc.
- * Hydrochloric acid
- * Cements and glues
- * Antistatic fabric softeners for clothes dryers
- * Masonry acid washing material

Note: *Extended warranties are not available in some instances. Extended warranty does not cover repairs to equipment installed in establishments with corrosive atmospheres, including but not limited to, dry cleaners, beauty shops, and printing facilities.*

Minimum Free Area in Square Inches Each Opening (Furnace Only) in a Confined Space

| Furnace Max BTUH.Input Rtg. | Air From Inside | Air From Outside | |
|-----------------------------|-----------------|-------------------|---------------------|
| | | Vertical Duct (a) | Horizontal Duct (b) |
| 60,000 | 100 | 15 | 30 |
| 80,000 | 100 | 20 | 40 |

- (a) 1 Square inch per 4000 BTU/hr Vertical Duct.
- (b) 1 Square inch per 2000 BTU/hr Horizontal Duct.

CONFINED

LESS THAN 50 CU. FT. PER 1000 BTU/HR INPUT ALL EQUIP. INSTALLED

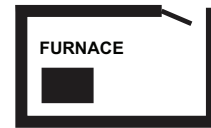

All air from inside the building The confined space shall be provided with two permanent openings communicating directly with an additional room(s) of sufficient volume so that the combined volume of all spaces meets the criteria for an unconfined space. The total input of all gas utilization equipment installed in the combined space shall be considered in making this determination. Refer to the Minimum Free Area in square inches for confined spaces table, for minimum open areas required.

CONFINED SPACE AIR FROM INSIDE BUILDING

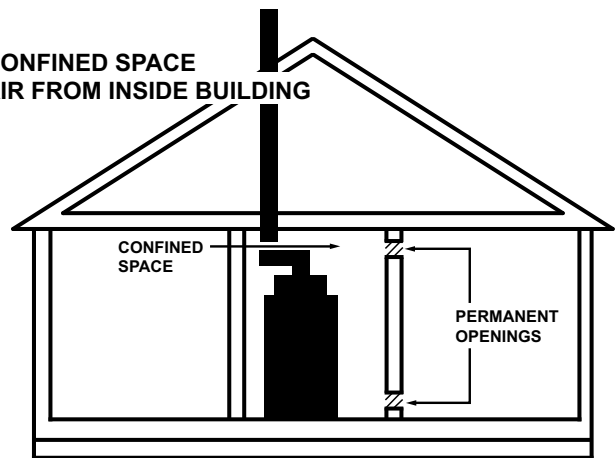

Furnace General Installation

All air from outdoors The confined space shall be provided with two permanent openings, one commencing within 12 inches of the top and one commencing within 12 inches of the bottom of the enclosure. The openings shall communicate directly, or by ducts, with the outdoors or spaces (crawl or attic) that freely communicate with the outdoors. Refer to the Minimum Free Area in square inches for confined spaces table, for minimum open areas required.

**CONFINED SPACE
AIR FROM OUTDOORS**

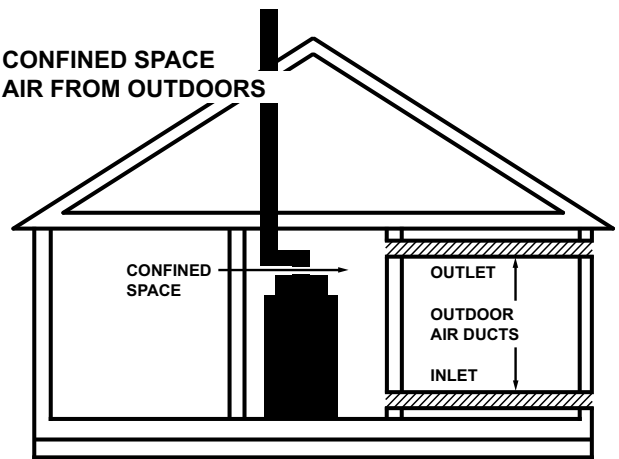

**CONFINED SPACE
AIR FROM VENTILATED ATTIC/CRAWL SPACE**

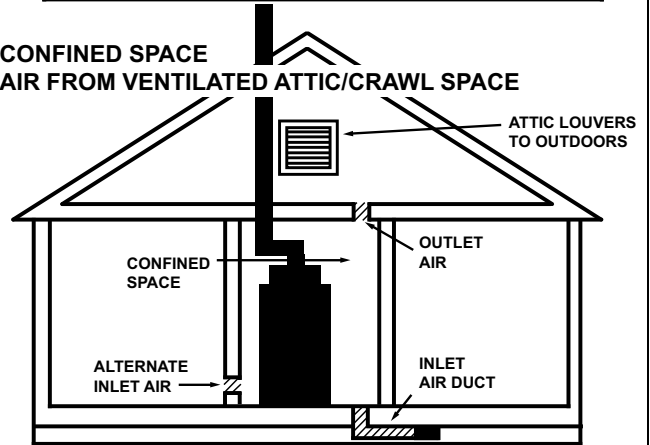

**CONFINED SPACE
AIR FROM VENTILATED ATTIC**

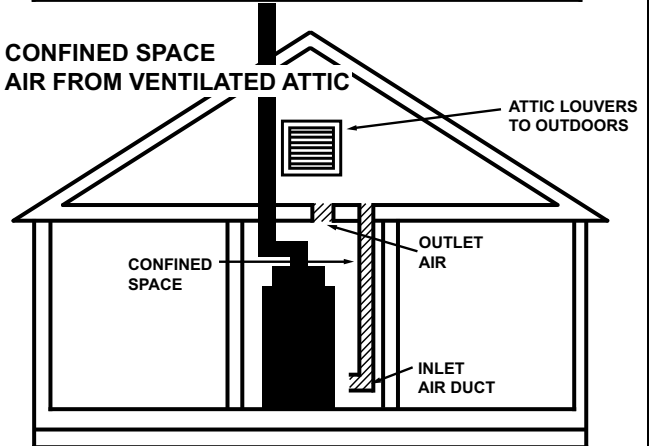

Duct Connections

| | |
|---|--|
| <p>Air duct systems should be installed in accordance with standards for air conditioning systems, National Fire Protection Association Pamphlet No. 90. They should be sized in accordance with ACCA Manual D or whichever is applicable. Check on controls to make certain they are correct for the electrical supply.</p> <p>Central furnaces, when used in connection with cooling units, shall be installed in parallel or on the upstream side of the cooling units to avoid condensation in the heating element, unless the furnace has been specifically approved for downstream installation. With a parallel flow arrangement, the dampers or other means used to control flow of air shall be adequate to prevent chilled air from entering the furnace, and if manually operated, must be equipped with means to prevent operation of either unit unless the damper is in full heat or cool position.</p> <p>Flexible connections of nonflammable material may be used for return air and discharge connections to reduce the transmission of vibration. Though these units have been specifically designed for quiet, vibration free operation, air ducts can act as sounding boards and could, if poorly installed, amplify the slightest vibration to the annoyance level.</p> | <p>When the furnace is located in a utility room adjacent to the living area, the system should be carefully designed with returns which minimize noise transmission through the return air grille. Although these winter air conditioners are designed with large blowers operating at moderate speeds, any blower moving a high volume of air will produce audible noise which could be objectionable when the unit is located very close to a living area. It is often advisable to route the return air ducts under the floor or through the attic. Such design permits the installation of air return remote from the living area (i.e. central hall).</p> <p>When the furnace is installed so that the supply ducts carry air circulated by the furnace to areas outside the space containing the furnace, the return air shall also be handled by a duct(s) sealed to the furnace and terminating outside the space containing the furnace.</p> <p>For furnaces not equipped with a cooling coil, it is recommended that the outlet duct be provided with a removable access panel. The opening shall be accessible when the furnace is installed and shall be of such a size that the heat exchanger can be viewed for possible openings using light assistance or a probe can be inserted for sampling the air stream. The removable cover must be sealed to prevent air leaks.</p> |
| <p>Where there is no complete return duct system, the return connection must be run full size from the Furnace to a location outside the utility room, basement, attic, or crawl space. Do Not install return air through the back of the Furnace cabinet. Do Not install return air through the side of the furnace cabinet on horizontal applications without following the guidelines in the Return Air Filters section in the figure for Horizontal furnace with side return.</p> | |
| <p>Carbon monoxide, fire or smoke can cause serious bodily injury, death, and/or property damage.</p> <p>A variety of potential sources of carbon monoxide can be found in a building or dwelling such as gas-fired clothes dryers, gas cooking stoves, water heaters, furnaces and fireplaces. The U.S. Consumer Product Safety Commission recommends that users of gas-burning appliances install carbon monoxide detectors as well as fire and smoke detectors per the manufactures installation instructions to help alert dwelling occupants of the presence of fire, smoke or unsafe levels of carbon monoxide. These devices should be listed by Underwriters Laboratories, Inc. <i>Standards for Single and Multiple Station Carbon Monoxide Alarms, UL 2034.</i></p> | <p>Note: <i>The manufacturer of your Furnace DOES NOT test any detectors and makes no representations regarding any brand or type of detector.</i></p> |
| <p>Note: Seal per local codes</p> | |

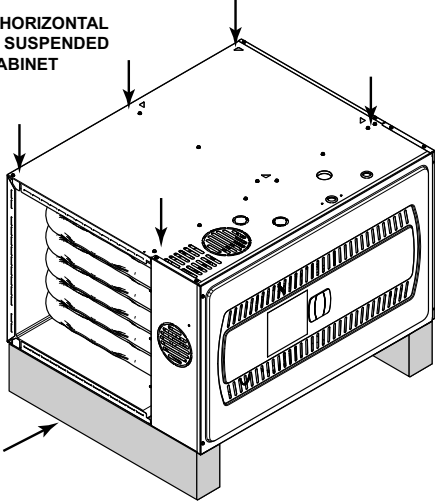
| | |
|--|---|
| <p>In horizontal applications, the furnace must be supported with one of the following methods.</p> <ol style="list-style-type: none"> 1. Support below with non-combustible material as shown in the illustration. 2. Use BAYHANG kit. See kit instructions. 3. Use unistrut with cabling to provide support from under the unit. 4. Use strapping material in locations shown in illustration. | <p>WHEN SUSPENDING THE HORIZONTAL FURNACE, IT SHOULD BE SUSPENDED BY ATTACHING TO THE CABINET IN THE PLACES SHOWN.</p>  <p>WHEN SUPPORTING THE FURNACE FROM BELOW, SUPPORT FRONT TO BACK (AS SHOWN) OR SIDE TO SIDE.</p> |
|--|---|

Furnace General Installation

Table 3. Supply Duct Connections

Upflow Furnace with Coil

1. Bend furnace flanges up.
2. Set the coil on top of the furnace.
3. Screw through the coil cabinet into the furnace flange. Guide holes are located on the coil.
4. Seal per local codes and requirements.

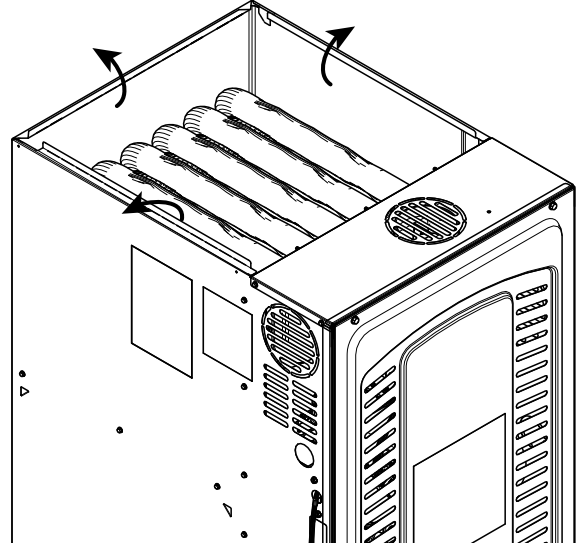

Furnace in Horizontal Left with Coil

1. Bend furnace flanges up.
2. Support the furnace and coil independently.
3. Screw through the coil cabinet into the furnace flange. Guide holes are located on the coil.
4. Seal per local codes and requirements.

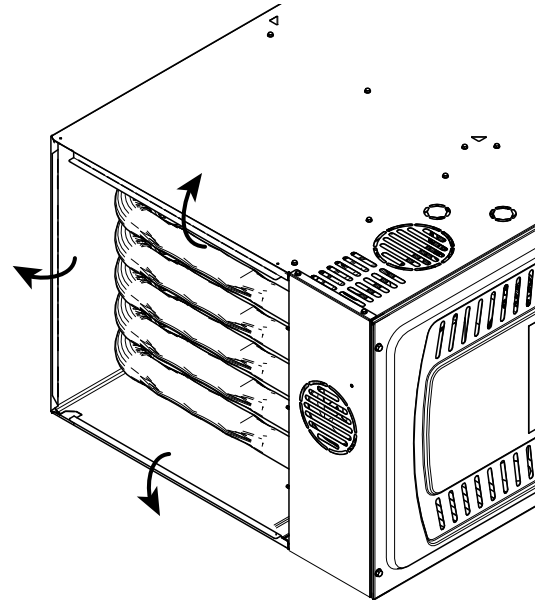

Furnace in Horizontal Right with "A" Coil

1. Bend furnace flanges down.
2. Support the furnace and coil independently.
3. Match the coil up flush to the back of the furnace.
4. Seal per local codes and requirements.

Note: Flat or dedicated horizontal coils may require flanges to be bent upward.

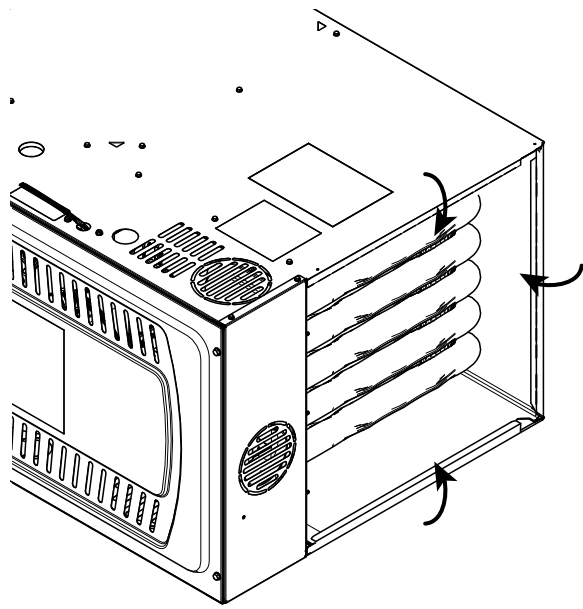

Furnace General Installation

Table 4. Return Duct Connections

| | |
|---|--|
| <p>Return Ducting General Guidelines</p> <ul style="list-style-type: none">• Back returns are not allowed on any S-Series Furnaces• Side returns are not allowed on downflow or horizontal S-Series Furnaces• Mounting flanges must be located on ducting• Shoot screws through the mount flanges into the furnace cabinet• Always seal per local codes and requirements• Furnace, coil, and ducting must be supported separately• An external overflow drain pan must be installed in all applications over a finished ceiling to prevent property damage• Minimum return air is 55°F and maximum is 80°F. | |
| <p>Upflow Furnace with Bottom Return in Closet with Remote Filter</p> <ol style="list-style-type: none">1. Remove the bottom plate.2. Set the furnace on the base inside closet.3. Install remote filter.4. Seal per local codes and requirements. |  |
| <p>Upflow Furnace with Bottom Return in Closet with Filter Box</p> <ol style="list-style-type: none">1. Remove the bottom plate.2. Set the furnace on the filter box inside closet.3. Must have grille present for air.4. Seal per local codes and requirements. |  |

Table 4. Return Duct Connections (continued)

| | |
|--|--|
| <p>Upflow Furnace with Bottom Return Mounted on a Ducted Pedestal</p> <ol style="list-style-type: none"> 1. Remove the bottom plate. 2. Set the furnace on the ducted pedestal. The ducted pedestal will use ducted air from a remote location. 3. Install filter at a remote location. 4. Seal per local codes and requirements. |  |
| <p>Upflow Furnace with Bottom Return Mounted on a Ducted Pedestal with Filter Box</p> <ol style="list-style-type: none"> 1. Remove the bottom plate. 2. Set the furnace on the filter box. The ducted pedestal will use ducted air from a remote location. 3. Seal per local codes and requirements. |  |

Furnace General Installation

Table 4. Return Duct Connections (continued)

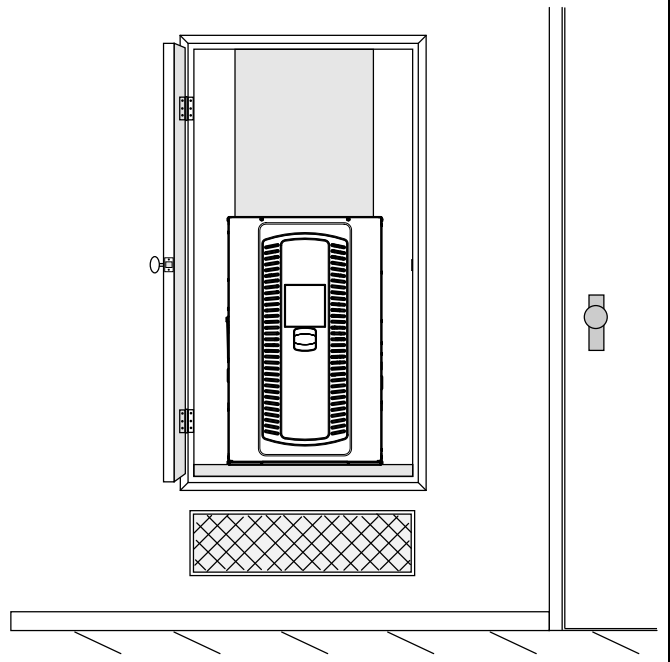
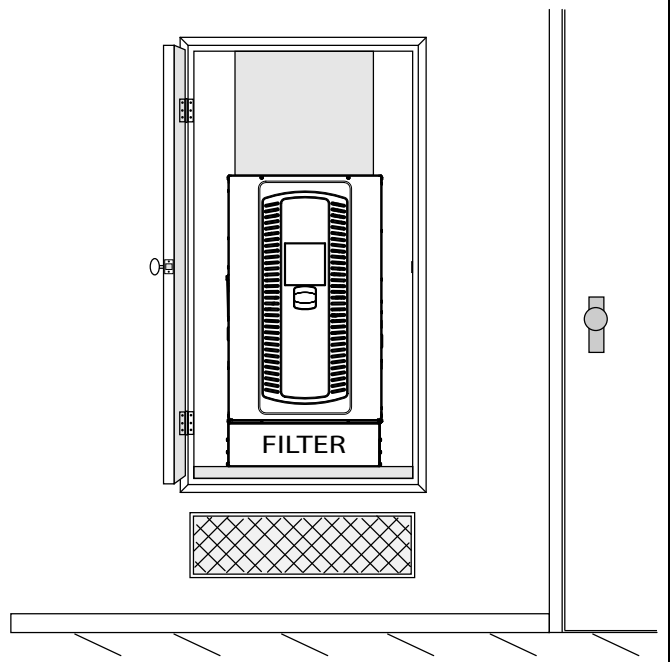
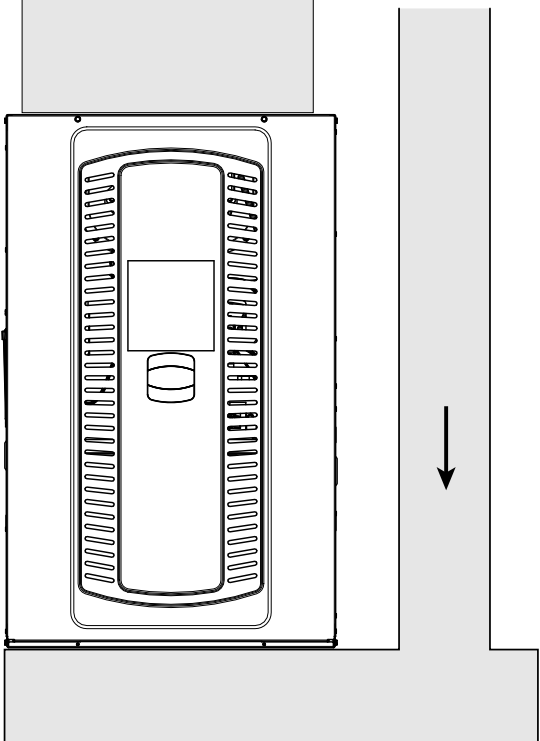
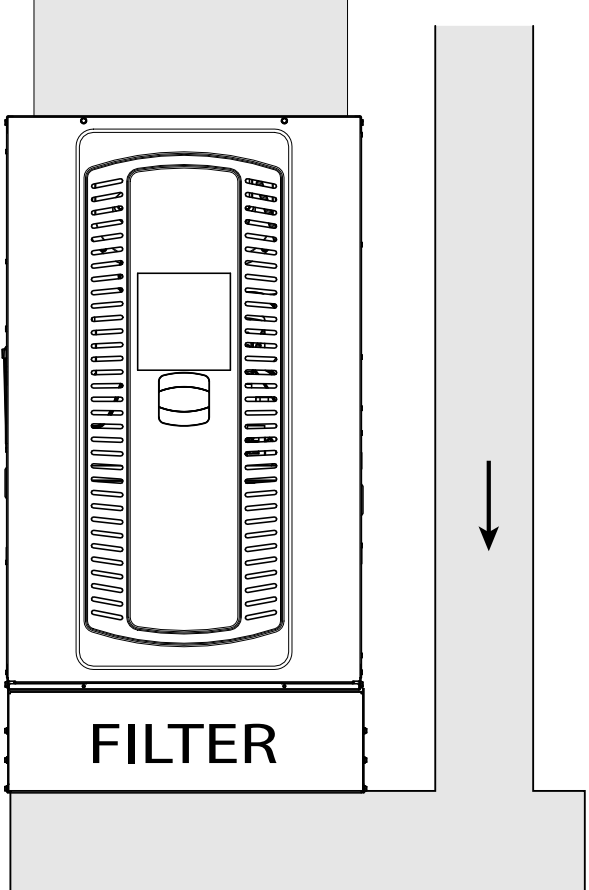
| | |
|---|--|
| <p>Upflow Furnace with Bottom and Side Returns Mounted on a Ducted Pedestal with Side Return and Filter Box</p> <p>Important: Make sure the thermostat wiring hole is sealed on the cabinet side with the side return.</p> <p>Important: Make sure not to cut the cabinet in the "No Cut" area.</p> <ol style="list-style-type: none"> 1. Remove the bottom plate. 2. Create ducting and set the furnace in place. <p>Note: Use Optional BAYLIFT kit to lift furnace. Follow kit instructions.</p> <p>Note: The furnace bottom pedestal must be a minimum of 6" in height.</p> <ol style="list-style-type: none"> 3. Match the filter cabinet flush to the back and bottom sides of the furnace cabinet and secure in place with screws. 4. Mark the two areas to be cut out for the return air. 5. Cut out the two sections of the cabinet and BAYLIFT kit to be removed. 6. Attach ducting to the filter box. 7. The ducted pedestal will use ducted air from a remote location. 8. Seal per local codes and requirements. | |
| <p>Cabinet cutout when used with BAYLIFT</p> | <p>21" Filter Cabinet with BAYLIFT Kit shown</p> <p>No Cut Area Cutouts Flush with back of furnace cabinet</p> |

Table 4. Return Duct Connections (continued)

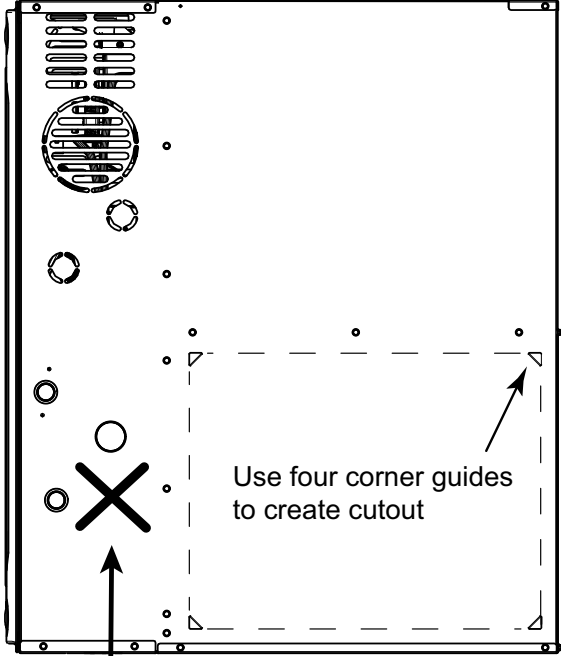
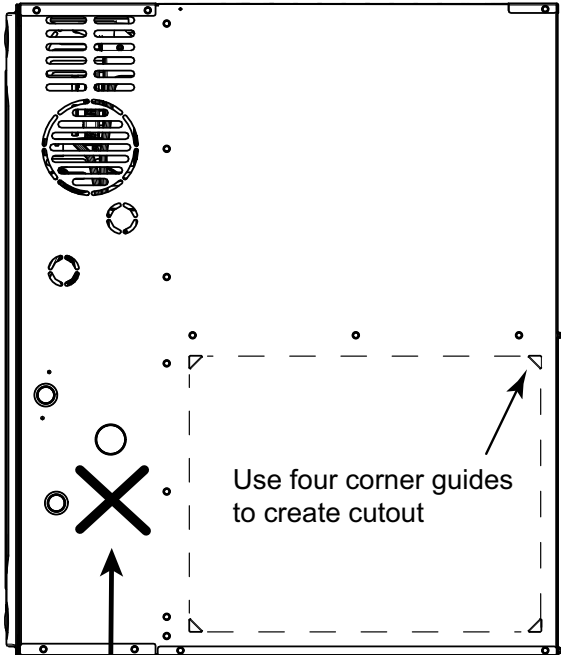
| | |
|---|---|
| <p>Upflow Furnace with Side Return</p> <p>Important: Make sure the thermostat wiring hole is sealed on the cabinet side with the side return.</p> <p>Important: Make sure not to cut the cabinet in the "No Cut" area.</p> <ol style="list-style-type: none">Using guides, remove the cutout for the side return.Create ducting and set the furnace in place. Use screws to attach ducting to the furnace cabinet. <p>Note: If using a filter box, use a transition, if possible, to attach the filter box to the furnace cabinet.</p> <ol style="list-style-type: none">Seal bottom panel per local codes and requirements.Seal all other panels per local codes and requirements. |  <p>The diagram shows the front panel of a furnace cabinet with various components like filters and a circular return grille. A dashed rectangular box on the right side indicates the area for a side return cutout. An arrow points to the top-right corner of this dashed box with the text "Use four corner guides to create cutout". On the left side, there is a large 'X' over a circular area, with an arrow pointing to it from the label "No Cut Area" below the diagram.</p> |
| <p>Upflow Furnace with Two Side Returns</p> <p>Important: One of the sides must have a transition to allow the thermostat wiring to exit the cabinet.</p> <p>Important: If a transition is not a viable option, a hole will need to be drilled in the side of the cabinet for the thermostat wiring to exit.</p> <p>Important: Make sure not to cut the cabinet in the "No Cut" area.</p> <p>Note: If using one transition, the thermostat wiring will exit on the transition side.</p> <ol style="list-style-type: none">Using guides, remove the two cutouts for the side returns.Create ducting and set the furnace in place. Use screws to attach ducting to the furnace cabinet. <p>Note: If using a filter boxes, use transitions, if possible, to attach the filter boxes to the furnace cabinet.</p> <ol style="list-style-type: none">Seal bottom panel per local codes and requirements.Seal all other panels per local codes and requirements. |  <p>This diagram is identical to the one above, showing the furnace cabinet with a dashed box for a side return cutout and a "No Cut Area" marked with an 'X' on the left side. It includes the same instructions and labels for using corner guides and avoiding the no-cut area.</p> |

Return Air Filters

TYPICAL AIR FILTER INSTALLATIONS

Filters are not factory supplied for furnaces. Filter size needed will be dependent on type of filter and CFM requirement. Filters must be installed externally to the unit.

Important: *It is recommended to transition return ducting to the same size as the opening. It is acceptable for return duct or filter frame to extend forward of the opening but plastic plugs MUST be installed in any opening that the duct or filter frame may cover.*

Return Air Filters

| Furnace Width | Bottom Return Filter Qty and Size |
|---------------|-----------------------------------|
| 17-1/2" | 1 — 16" x 25" x 1" |

Note: *For upflow airflow furnaces where the airflow requirement exceeds 1600 CFM - Furnaces will require return air openings and filters on: (1) both sides, or (2) one side and the bottom, or (3) just on the bottom.*

Preparation for Upflow Bottom and Side Return Air Filter Installations

All return air duct systems should provide for installation of return air filters.

1. Determine the appropriate position to set the furnace in order to connect to existing supply and return ductwork.
2. For upflow side return installations, remove the insulation around the opening in the blower compartment
3. The side panels of the upflow furnace include locating notches that are used as guides for cutting an opening for return air, refer to the figure and the upflow furnace outline drawing for duct connection dimensions for various furnaces.
4. If a 3/4" flange is to be used for attaching the air inlet duct, add to cut where indicated by dotted lines. Cut corners diagonally and bend outward to form flange.
5. If flanges are not required, and a filter frame is installed, cut between locating notches as in illustration.
6. The bottom panel of the upflow furnace must be removed for bottom return air.

UPFLOW FURNACES ONLY

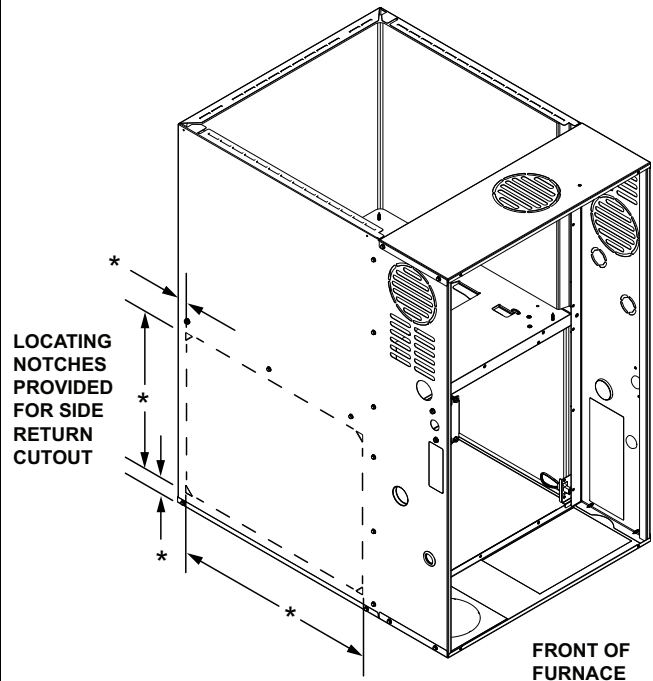

* SEE OUTLINE DRAWING

1. When the furnace is installed in the horizontal right or left application and a return duct is attached to the top side, do not install a filter in the return duct directly above the furnace. Install the filter in a remote location.
 When the furnace is installed in the horizontal right or left application and a close coupled (less than 36") return duct is attached to the bottom side of the furnace as shown above, securely attach a 1/2" mesh metal hardware cloth protective screen to the inside bottom of the filter grille **to prevent personal injury from contacting moving parts when reaching into the return opening to replace the filter.**
 Close coupled (less than 36") return (filter directly beneath bottom side return) is not recommended due to noise considerations.
2. Connect the duct work to the furnace. See Outline Drawing for supply and return duct size and location.
 Flexible duct connectors are recommended to connect both supply and return air ducts to the furnace.
 If only the front of the furnace is accessible, it is recommended that both supply and return air plenums are removable.
3. When replacing a furnace, old duct work should be cleaned out. Thin cloths should be placed over the registers and the furnace fan should be run for 10 minutes. Don't forget to remove the cloths before you start the furnace.
4. **The horizontal installation of the upflow furnace requires an external filter section. Filter kits are available for horizontal applications.**

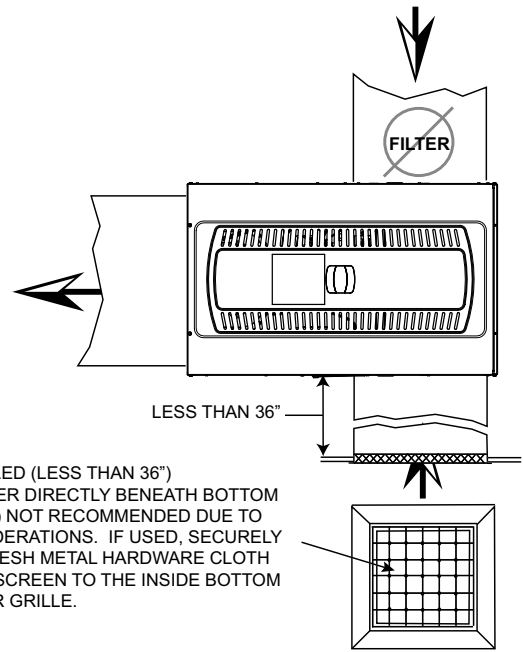

CLOSE COUPLED (LESS THAN 36") RETURN (FILTER DIRECTLY BENEATH BOTTOM SIDE RETURN) NOT RECOMMENDED DUE TO NOISE CONSIDERATIONS. IF USED, SECURELY ATTACH 1/2" MESH METAL HARDWARE CLOTH PROTECTIVE SCREEN TO THE INSIDE BOTTOM OF THE FILTER GRILLE.

RETURN AIR FILTERS FOR FURNACE IN HORIZONTAL CONFIGURATION

When the Furnace is installed in the horizontal configuration, the return air filters must be installed exterior to the furnace cabinet. Remote filter grilles may be used for homeowner convenience or the filters may be installed in the duct work upstream of the furnace.

Electrical Connections

Make wiring connections to the unit as indicated on enclosed wiring diagram. As with all gas appliances using electrical power, this furnace shall be connected into a permanently live electric circuit. It is recommended that furnace be provided with a separate "circuit protection device" electric circuit. The furnace must be electrically grounded in accordance with local codes or in the absence of local codes with the National Electrical Code, ANSI/NFPA 70, if an external electrical source is utilized. **The integrated furnace control is polarity sensitive.** The hot leg of the 120V power supply must be connected to the black power lead as indicated on the wiring diagram. Refer to the SERVICE FACTS literature and unit wiring diagram attached to furnace.

Field Wiring

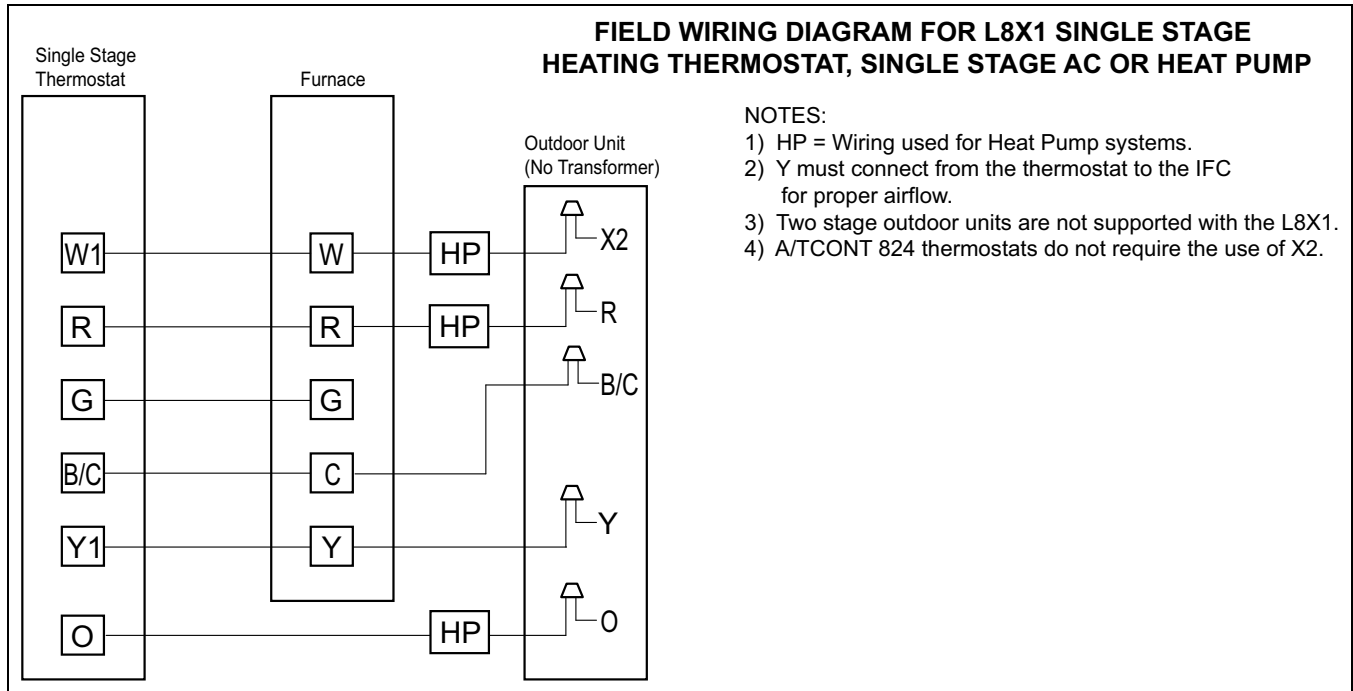

General Start-up and Adjustment

The following sections give instructions for the general start-up and adjustment of the gas furnaces.

Preliminary Inspections

| | |
|--|---|
| <p>With gas and electrical power "OFF", ensure:</p> <ol style="list-style-type: none"> 1. Duct connections are properly sealed. 2. Filters are in place. 3. Venting is properly assembled. 4. Blower vestibule panel is in place and all screws in place. | <p>Turn knob on main gas valve within the unit to the "OFF" position. Turn the external gas valve to "ON". Purge the air from the gas lines. After purging, check all gas connections for leaks with a soapy solution.</p> <p>— DO NOT CHECK WITH AN OPEN FLAME. Allow 5 minutes for any gas that might have escaped to dissipate. Turn the gas valve in the unit to the "ON" position.</p> <p>Turn the toggle switch on the Gas Valve in the unit to the "ON" position.</p> |
|--|---|

Lighting Instructions

| | |
|--|---|
| <p>Lighting instructions appear on each unit. Each installation must be checked out at the time of initial start up to ensure proper operation of all components. Check out should include putting the unit through one complete cycle as outlined below.</p> <p>Turn on the main electrical supply and set the comfort control above the indicated temperature. The ignitor will automatically heat, then the gas valve is energized to permit the flow of gas to the burners. After ignition and flame is established, the flame control module monitors the flame and supplies power to the gas valve until the comfort control is satisfied.</p> | <div style="background-color: black; color: white; text-align: center; padding: 5px;">⚠ WARNING</div> <div style="background-color: black; color: white; text-align: center; padding: 5px;">FIRE OR EXPLOSION HAZARD!</div> <p>Failure to follow this Warning could result in property damage, severe personal injury, or death. Do NOT attempt to manually light the furnace.</p> |
|--|---|

| | |
|--|--|
| <p>To shut off</p> <p>For complete shutdown: Turn the toggle or control switch located on the main gas valve inside the unit to the "OFF" position and the external main gas shutoff valve to the "OFF" position. Disconnect the electrical supply to the unit.</p> | |
| <p>Whenever your house is to be vacant, arrange to have someone inspect your house for proper temperature. This is very important during freezing weather. If for any reason your furnace should fail to operate damage could result, such as frozen water pipes.</p> | <div style="background-color: black; color: white; text-align: center; padding: 5px;">⚠ CAUTION</div> <div style="background-color: black; color: white; text-align: center; padding: 5px;">FREEZE CAUTION!</div> <p>Failure to follow this Caution could result in property damage or personal injury. If complete furnace shutdown is done during the cold weather months, provisions must be taken to prevent freeze-up of all water pipes and water receptacles.</p> |

Control and Safety Switch Adjustment

| | |
|---|---|
| <p>LIMIT SWITCH CHECK OUT</p> <p>The limit switch is a safety device designed to close the gas valve should the furnace become overheated. Since proper operation of this switch is important to the safety of the unit, it must be checked out on initial start up by the installer.</p> | <p>To check for proper operation of the limit switches, set the thermostat to a temperature higher than the indicated temperature to bring on the gas valve. Restrict the airflow by blocking the return air to the blower. When the furnace reaches the maximum outlet temperature as shown on the rating plate, the burners must shut off. If they do not shut off after a reasonable time and overheating is evident, a faulty limit switch is probable and the limit switch must be replaced. After checking the operation of the limit control, be sure to remove the paper or cardboard from the return air inlet, or reconnect the blower.</p> |
|---|---|

Furnace Combustion Air Exhaust Options

Note: Default is left side for electric and gas connections.

The following sections give instructions for the different furnace orientations and the options for venting the exhaust combustion air.

Important: When looking at the different orientations, the direction of the combustion air exhaust in the illustration's description is after the furnace has been rotated, if needed.

Table 5. Venting Options for Upflow Applications

| <p>Refer to the illustrations below to find the approved venting options for upflow furnace.</p> <p>Note: Left side venting is not allowed for upflow furnaces.</p> <p>Important: The exhaust must be vented to the outdoors.</p> | |
|--|---|
| Upflow Orientation or Installation | |
| <p>Vented out top.</p>  | <p>Vented through right side.</p>  |

Table 6. Venting Options for Horizontal Left Applications

| <p>Refer to the illustrations below to find the approved venting options for horizontal left furnace.</p> <p>Important: The exhaust must be vented to the outdoors.</p> | |
|---|---|
| Horizontal Left Orientation or Installation | |
| <p>Vented out top.</p>  | <p>Vented through left side.</p>  |

Table 7. Venting Options for Horizontal Right Applications

| <p>Refer to the illustrations below to find the approved venting options for horizontal right furnace.</p> <p>Note: Top venting is not allowed for horizontal right furnaces.</p> <p>Important: The exhaust must be vented to the outdoors.</p> | |
|--|--|
| Horizontal Right Orientation or Installation | |
| <p>Vented through right side.</p>  | |

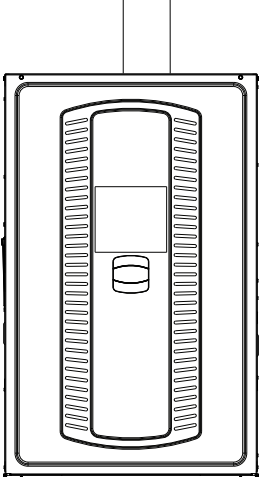
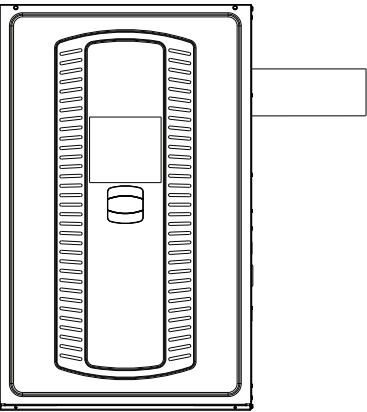
Combustion Air Conversions

| | |
|---|--|
| <p>Important: After deciding the orientation of the flue outlet, cut the metal tabs around the appropriate 5" metal cutout on the furnace cabinet and remove the cutout, if necessary.</p> <p>Note: When rotating the inducer it may be necessary to cut the wire tie. A new wire tie must be installed once the inducer is rotated.</p> <p>Note: Self-tapping screws are recommended for attaching the vent pipe to the inducer outlet.</p> | <p>Pressure Switch locations</p> <p>L8X1 — Pressure Transducer and Pressure Switch are connected to the hot header.</p> |
| <p>Upflow orientation with top venting</p> <p>No changes need to be made to the inducer when installing the furnace in upflow position when vented through the top.</p> <p>Note: Self-tapping screws are recommended for attaching the vent pipe to the inducer outlet.</p> |  |

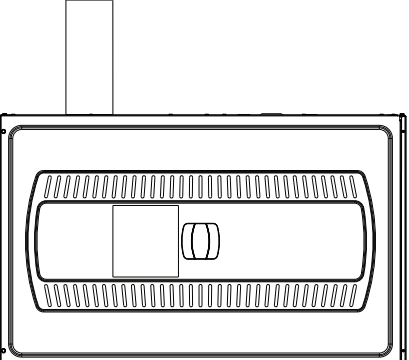
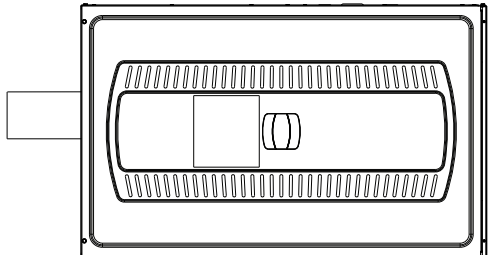
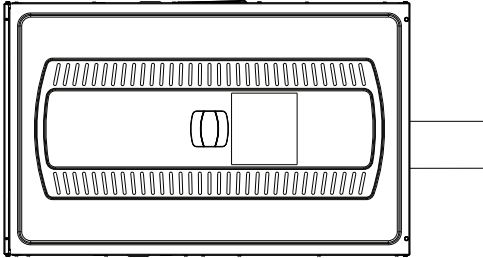
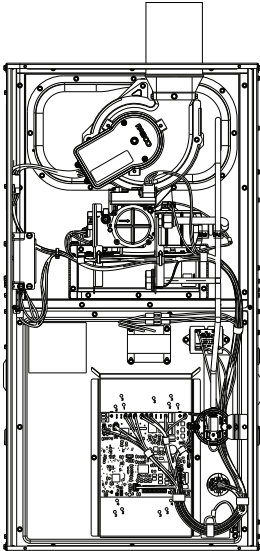
Furnace Combustion Air Exhaust Options

Upflow orientation with right side venting

Before proceeding, lay unit on its back to make the conversion easier. The following changes need to be made to the inducer when installing the furnace in upflow position with the combustion air vented out the left side.

1. Remove the four screws holding the inducer in place.
2. Rotate the inducer so the inducer outlet is pointing towards the 5" cutout.
3. Secure the inducer in place using the screws removed in step 1.
4. Attach the vent to the inducer outlet.

Note: Self-tapping screws are recommended for attaching the vent pipe to the inducer outlet.

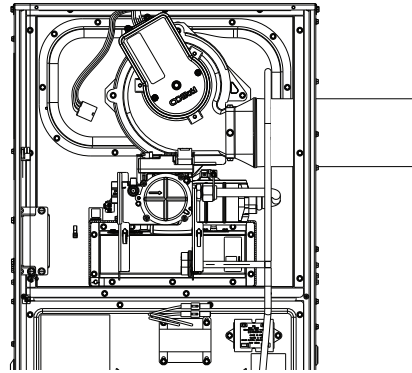

Horizontal left orientation with left side venting

No changes need to be made to the inducer when installing the furnace in upflow position with the combustion air vented through the top.

Note: Self-tapping screws are recommended for attaching the vent pipe to the inducer outlet.

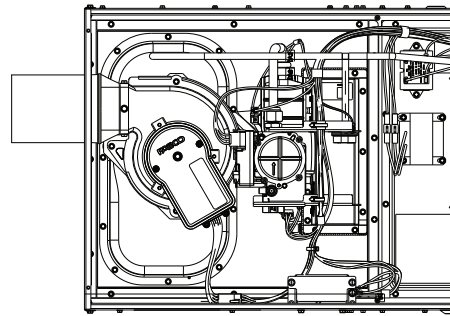

Horizontal left orientation with top venting

Before proceeding, lay unit on its back to make the conversion easier. The following changes need to be made to the inducer when installing the furnace in upflow position with the combustion air vented out the left side.

1. Remove the four screws holding the inducer in place.
2. Rotate the inducer so the inducer outlet is pointing towards the 5" cutout.
3. Secure the inducer in place using the screws removed in step 1.
4. Attach the vent to the inducer outlet.

Note: Self-tapping screws are recommended for attaching the vent pipe to the inducer outlet.

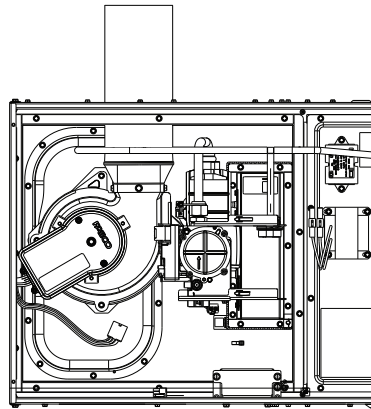

Horizontal right orientation with right side venting

No changes need to be made to the inducer when installing the furnace in upflow position with the combustion air vented through the top.

Note: Self-tapping screws are recommended for attaching the vent pipe to the inducer outlet.

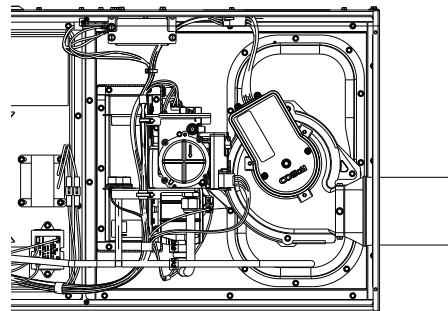

Integrated Furnace Control

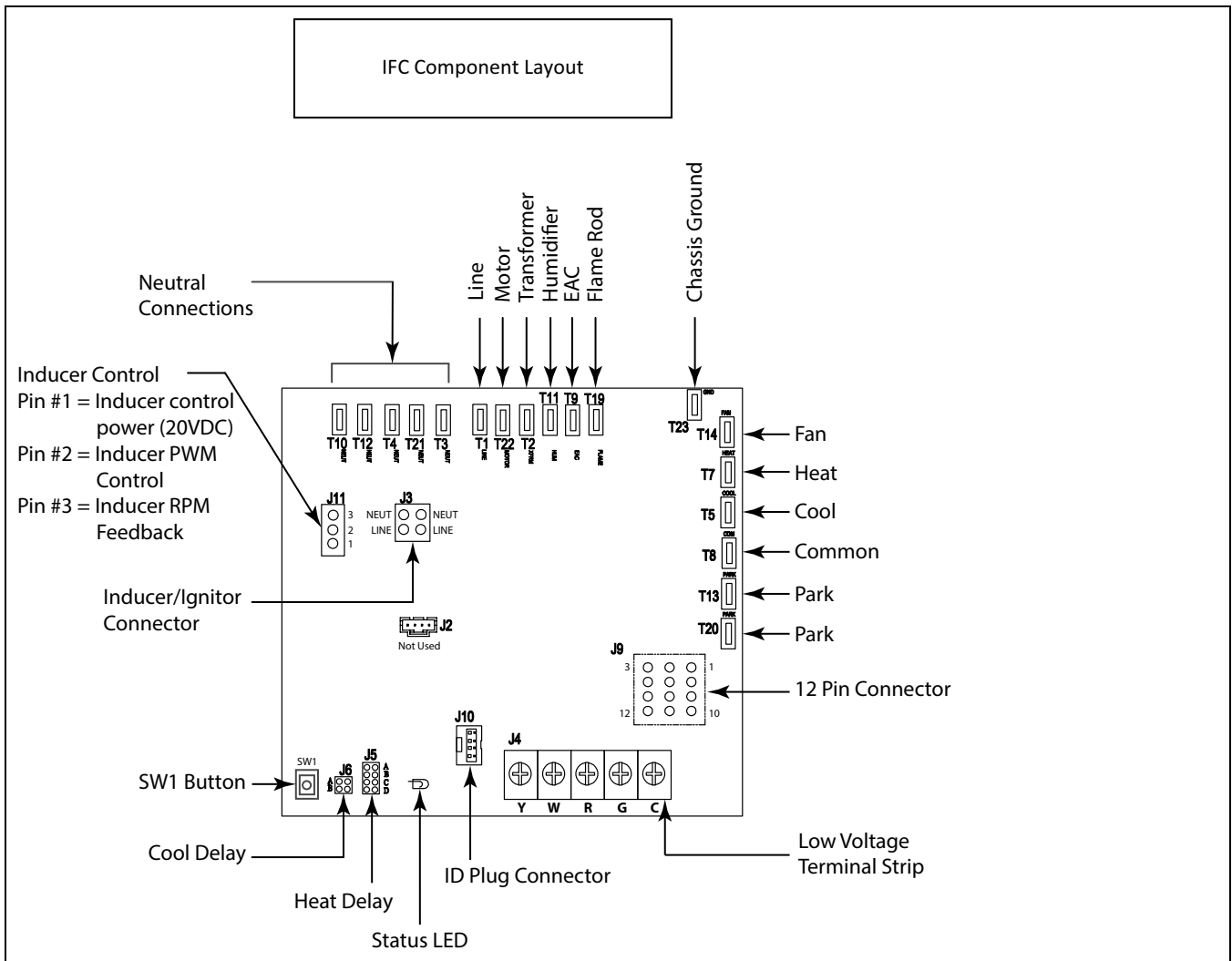

Refer to Service Facts for 12 Pin Connector inputs and outputs.

Setting Airflow

With all ductwork connected and a clean filter in place, measure the External Static Pressure (ESP) of the unit in locations below. Use the appropriate airflow table for the furnace and outdoor unit installed.

Measurements must be made prior to the evaporator coil, if equipped, and after the filter.

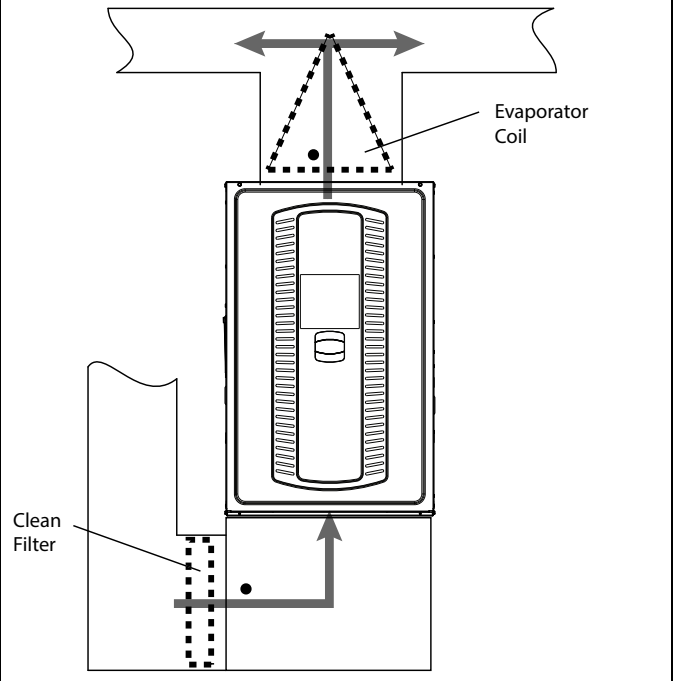

Furnace Airflow (CFM) Vs. External Static Pressure (in. W.C.)

| Model | Tap | | 0.1 | 0.3 | 0.5 | 0.7 | 0.9 |
|-----------------------|-----|-------|------|------|------|------|------|
| LSX1B060U3PXAA | 1 | SCFM | 829 | 689 | 549 | 410 | 270 |
| | | Watts | 83 | 95 | 107 | 119 | 130 |
| | 2 | SCFM | 1087 | 985 | 884 | 782 | 681 |
| | | Watts | 163 | 179 | 195 | 210 | 226 |
| | 3 | SCFM | 1210 | 1126 | 1043 | 959 | 876 |
| | | Watts | 211 | 228 | 245 | 262 | 279 |
| | 4 | SCFM | 1238 | 1157 | 1076 | 995 | 914 |
| | | Watts | 227 | 244 | 261 | 278 | 295 |
| | 5 | SCFM | 1481 | 1409 | 1338 | 1266 | 1195 |
| | | Watts | 381 | 399 | 417 | 435 | 453 |

Example 1: S8B1 (Default Tap 7)

Cooling / HP

- 2 Ton Single Stage Outdoor

- Total ESP = 0.7" W.C.
- Required Airflow = 1400 cfm (4T x 350 cfm/ton)
- New Tap Number = Tap 6

LED Status Codes

| LED Activity | Description | Color | Lockout Period ^(a) | Comments |
|------------------------------|--|-------|---|---|
| OFF (No LED Activity) | No 24 VAC Power to Control | — | N/A | Check incoming voltage ~120VAC |
| Red, Amber, Green | Power-up verification of LED | — | N/A | Displayed at power up or after any successful control reset, a one second display of each color in sequence. |
| Steady ON | Control Fault Detected Hard Lock-Out | RED | Until fault is removed | Control faults include relay failures, memory failures, or other hardware failures detected during power-up self-test or during other continuous operating checks. |
| Rapid Flash | Reversed Line Voltage Polarity | RED | Until fault is removed | Call For Heat Not required. No "W" nor "Y" or "G" input calls for heating, cooling, or continuous fan operation will be acknowledged until the fault is corrected. |
| 1 Flash | System Lockout Retries Exceeded | RED | 1 Hour Fixed | Retries are defined as failed ignition attempts, i.e. no flame sense established during the trial for ignition period and maintained through the flame stabilization period. Recycles are defined as loss of flame following completion of a successful ignition while in the run state, and there is no limit to the number of recycles. If the blower is already on when flame loss occurs, then it will remain on during the recycle light-off attempt. |
| 2 Flashes | Pressure Sensor Null Error: Inconsistent reading with inducer OFF, sensor may be electrically unplugged | RED | 30 second lockout during Call For Heat | Control waits 5 seconds after call for heat before displaying fault. Fault is displayed until fault condition corrects and lockout expires or call for heat is removed. |
| 3 Flashes | Pressure Sensor Span Error: Inconsistent reading with inducer ON, or inducer fails to reach target pressure. | RED | 5 minute lockout during Call For Heat | Span test maximum duration is 90 seconds. Once the span test fails, the fault is displayed until the lockout expires or Call For Heat is removed. Could be blocked vent, poor air hose connection, or an open circuit in the inducer harness. |
| 4 Flashes | High Limit Switch Open | RED | Until limit closes or Call For Heat is removed or 5 minutes during a Call For Heat or 1 hour lockout after 3 faults in a single Call For Heat | When an open limit is detected during a Call For Heat, the control energizes the blower on the heating speed, sets the inducer to maximum, and displays the fault. Lockout is until the limit closes and either a minimum of 5 minutes if during a Call For Heat, or upon removal of the Call For Heat. Three open limit events in a single Call For Heat results in a 1 hour lockout. Outside of a Call For Heat, an open high limit switch is ignored. |
| 5 Flashes | Flame Present with Gas Valve OFF | RED | 5 minutes during Call For Heat | When detected, the control energizes the inducer at the "Run" setting, energize the blower on Heat speed, and displays fault - No Call For Heat required. The control will perform a post-purge when the fault condition is corrected and then it will resume normal operation after any lockout has expired. |
| 6 Flashes | Auxiliary Limit Open | RED | Until limit closes or Call For Heat is removed or 5 minutes during Call For Heat | When detected during a Call For Heat, the control energizes the blower on the heating speed, sets the inducer to maximum, and displays the fault. Lockout is until the limit closes and either a minimum of 5 minutes if during a Call For Heat, or upon removal of the Call For Heat. Outside of a Call For Heat, an open auxiliary limit switch is ignored. |
| 7 Flashes | Gas Valve Circuit Shorted | RED | 1 hour lockout | Voltage sensed at the gas valve terminal with the safety relay in the de-energized state. The inducer is set to maximum speed. |
| Steady ON | OEM Factory Test Mode | AMBER | N/A | Cycle power to the furnace. |
| 1 Flash | Low Flame Sense | AMBER | N/A | Flame Sense Current is weak, less than 3 μ Amp |

LED Status Codes

| LED Activity | Description | Color | Lockout Period ^(a) | Comments |
|--------------------|---|-------|---|---|
| 2 Flashes | ID Plug Failure | AMBER | Short duration (30 seconds) heating mode lockout followed by a reset to determine if the ID Plug is now valid | Wrong ID Plug values for the specific board. Includes damaged ID plug, ID plug missing, etc. Heating mode operation is in lockout but Call for Cooling ("Y") and Continuous Fan ("G") requests will still be honored. |
| 3 Flashes | Control Fuse Open | AMBER | Operation continues after fault correction | The 3 Amp fuse is on the 24 VAC supply to the control. |
| Steady ON | Standby Normal Operation No Thermostat Requests | GREEN | N/A | No current Call for Heat ("W"), Call for Cooling ("Y"), or Continuous Fan ("G") input. |
| Rapid Flash | Clear Error History | GREEN | N/A | Press and hold the SW1 button for more than 5 seconds results in the display of this mode. Releasing the Button during this indication will cause the Error History to be cleared. The button must be released within 5 seconds after the LED begins this flash sequence. |
| 1 Flash | Call for Heating | GREEN | N/A | "W" or "W & G" or "W & Y" or "W & Y & G" |
| 2 Flashes | Call for Cooling | GREEN | N/A | "Y" or "Y & G" |
| 3 Flashes | Continuous Fan Operation | GREEN | N/A | "G" only |

^(a) Power cycle resets any lockout

Fault Code Recovery

Fault Code Recovery

- To view the last 5 faults, momentarily press the SW1 button.
- The last 5 faults will begin flashing on the STATUS LED.

Clearing the Last 5 Faults

- To clear the last 5 faults, locate SW1 button.
- Hold the SW1 button until STATUS LED starts blinking GREEN.
- Release and the GREEN LED will momentarily blink. This confirms the faults have been cleared.

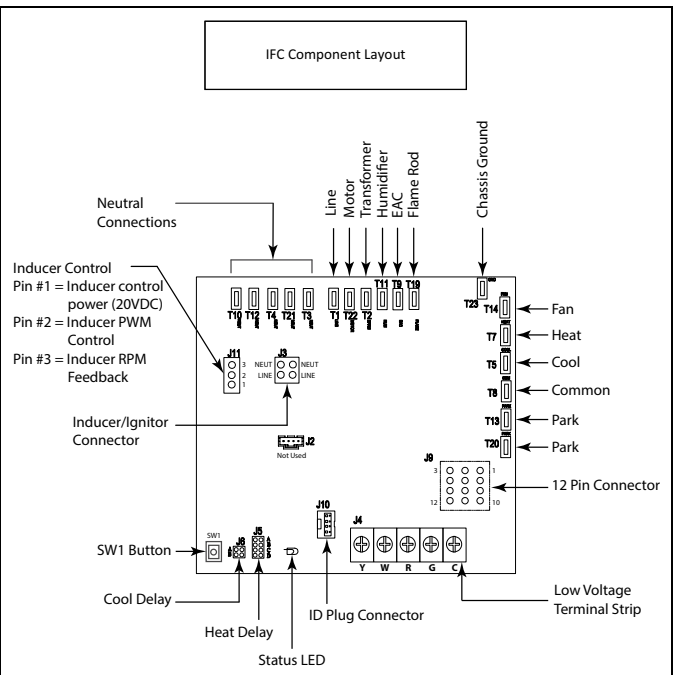

Sequence of Operation

EAC and HUM Timing

- EAC relay closes when the blower motor starts in any mode of operation.
- EAC relay opens when the blower motor stops.
- HUM relay closes on a gas heating call when the blower motor starts and flame is sensed.
- HUM relay opens when flame is no longer sensed, i.e. thermostat is satisfied.

Note: The EAC and HUM terminals are powered with line voltage.

Gas Heating

1. R – W contacts close on the thermostat sending 24VAC to the W low voltage terminal of the IFC. Technician should read 24VAC from W to C. The LED will flash GREEN one time per second.
2. The IFC performs a self-check routine and then confirms that the:
 - a. Main thermal limit (HI LIMIT), and reverse air flow (RAF) switches are closed by sending 24VAC out of the HLO terminal and monitoring the HLI input.
 - b. Burner box thermal switch (BBOX LIMIT) is closed by sending 24VAC out of the ROO terminal and monitoring the ROI input.
3. After steps a & b are confirmed, the inducer constant torque motor is energized and begins the Pressure Sensor Verification.
 - a. The first check is to make sure the transducer feedback is “null” or zero.
 - b. The second check is to make sure that the transducer feedback span is within specification. The inducer will engage to test the pressure transducer response.
 - c. Upon successful completion of steps a & b, the inducer will start the pre-purge.

Note: If the feedback is not correct, the IFC will time out after 90 seconds and flash the proper fault code.

4. As the inducer ramps up to factory default speed, the ignitor is energized. The ignitor warm up is approximately 17 seconds.

Note: If additional retries are needed, the ignitor warm up time is successively increased to a maximum of 30 seconds.

5. After the ignitor warm up, the 1st stage of the gas valve is energized allowing gas flow.
6. The burner system will ignite, providing current to the flame sensor. Proof of flame must be established within 4 seconds or a retry will occur.

Note: Typical flame current ranges from 7 – 10 micro-amps.

7. Once flame sense has been established, the inducer will ramp to the “run” speed. During this transition, the pressure switch will close and energize the 2nd stage of the gas valve.
8. After the “Heat On Delay” has completed, the indoor blower is energized.
9. When the temperature raises enough to satisfy the thermostat setting, contacts R-W will open.
10. The gas valve relay will open, closing the gas valve. The inducer will continue to run for approximately 30 seconds to remove any combustion by-products from inside the furnace.
11. The indoor blower continues to run to remove heat from the heat exchangers. The “blower off” time is field adjustable. The LED will turn to solid green when there is no active thermostat demand.

Cooling

1. R-Y1 and R-G contacts on the thermostat close sending 24VAC to the Y and G low voltage terminals on the IFC. Technician should read 24VAC between Y-C and between G-C. The LED will flash GREEN 2 times.
2. 24VAC is sent to the OD unit via thermostat wiring.
3. After a 6 second “Blower On Delay”, the indoor blower ramps to the cooling airflow.

Note: The blower on delay can be field adjusted to 45 seconds if desired but cannot be turned OFF.

4. When the temperature is lowered enough to satisfy the thermostat setting, contacts R-Y1 and R-G will open.
5. The OD unit shuts off and the indoor blower starts after a 45 second “Cool Off Delay”.

Note: The 45 second delay is not field adjustable, and cannot be turned OFF.

Sequence of Operation

Heat Pump

1. R-Y1-G contacts on the thermostat close sending 24VAC to the Y and G low voltage terminals on the IFC. Technician should read 24VAC between Y-C and between G-C.
The LED will flash GREEN 2 times.
2. 24VAC is sent to the OD unit via thermostat wiring.
3. After a 6 second "Blower On Delay", the indoor blower ramps to the HP heating airflow.

Note: *The blower on delay can be field adjusted to 45 seconds if desired but cannot be turned OFF.*

4. When the temperature is raised enough to satisfy the thermostat setting, contacts R-Y1 and R-G will open.
5. The OD unit shuts off and the indoor blower starts after a 45 second "Cool Off Delay".

Note: *The 45 second delay is not field adjustable, and cannot be turned OFF.*

About Trane and American Standard Heating and Air Conditioning

Trane and American Standard create comfortable, energy efficient indoor environments for residential applications. For more information, please visit www.trane.com or www.americanstandardair.com.



The manufacturer has a policy of continuous data improvement and it reserves the right to change design and specifications without notice. We are committed to using environmentally conscious print practices.